

## LED SECURITY AREA LIGHT

Catalog No. : LED29-PC-GR

Type : Area Light

Project Name :

Location :

Qty :

Date :



PROBRITE's versatile LED light is designed to generate 3300 Lumens, from a 29-watt bulb which delivers a 4000K bright white light. Additionally, this fixture has its dusk to dawn automatic operation, which will turn the light on at dusk and off at dawn. This durable and reliable light is constructed in a rugged, weather and rust-proof polycarbonate housing and can act as a standard area light or a security light.

### PRODUCT PERFORMANCE AT A GLANCE

SYSTEM WATTAGE	LUMENS	LPW	CRI	REPLACES (Incandescent)
29W	3300 lm	200 lm/w	>70	200W



DUSK-TO-DAWN

#### HOUSING

Constructed in a rugged, weather and rust-proof polycarbonate housing

#### OPTICS

Prismatic acrylic polycarbonate lens, provides wide and even light coverage without visible "hot-spots" on the lens and gives superior lighting experience.

#### FINISH

Fade, weather, and abrasion resistant, electrostatically applied, thermally cured, triglycidal isocyanurate (TGIC) textured polyester powdercoat gray paint finish.

#### IP RATING & LISTINGS

LED light engine is weather proof and water tight, Energy Star, UL Listed, and suitable for Wet Location.

#### MOUNTING

It can be mount directly on wall or with extension arm on wall and poles (extension arm sold separately).

#### WARRANTY

Covered by a 5-year limited warranty. See [probrite.com/warranty](http://probrite.com/warranty) for details.

## PRODUCT SPECIFICATION

Product Dimensions	: 11.80" x 8.70" x 11.90"
Weight	: 1.98 lbs
Lumens	: 3300
LED Wattage	: 29W
Efficacy	: 113
CRI	: >70
Replaces (Incandescent)	: 200W
Mounting	: Wall Mount
Frequency	: 50-60Hz
THD (Total Harmonic Distortion)	: <20%
PF(Power Factor)	: >0.9
Ambient Operating Temperature	: (-30)-40°C
Input Voltage	: 120V
LED Chip	: -
Photocell	: Yes
Driver	: Non-dimming
Standard Lifetime	: 50,000 hrs
Standard Warranty	: 5 Years
Water Proofing Grade	: Suitable for wet location
CCT	: 4000K Bright White Light
Certifications	: Energy Star, FCC Certified, UL Certified

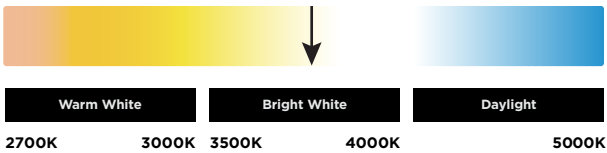

**SUGGESTED MOUNTING HEIGHT:**  
6-12 FT.(1.8-3.7 M)

## 3D PHOTOMETRIC VIEW

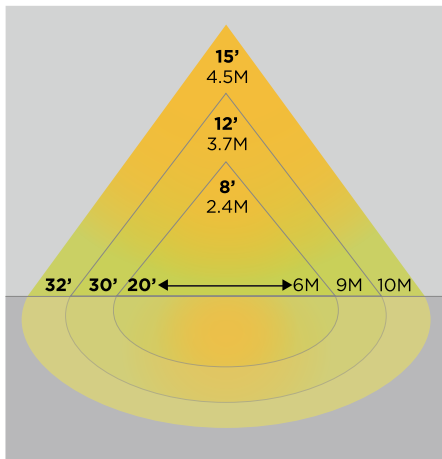

## PRODUCT LINE DRAWING

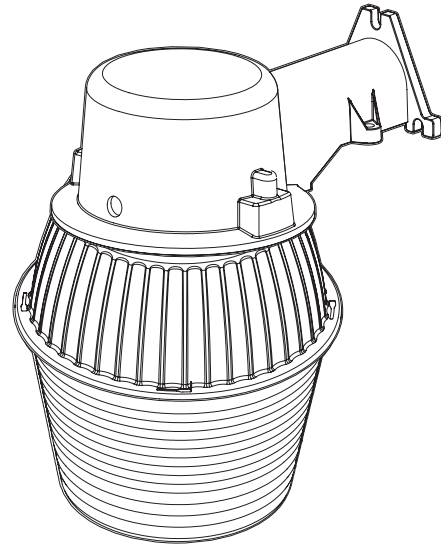

## APPLICATION

### SUITABLE FOR MULTIPLE APPLICATIONS

- SECURITY • GENERAL LIGHTING • ENTRYWAYS
- DRIVEWAYS • BACKYARDS • SIGNAGE

