

NOTICE

- * Please make sure that you have all parts indicated and they are in good condition before you begin assembly of this item. Refer to part list and hardware list below for guidance.
- * This item should be assembled on a soft surface to prevent scratching the finish during assembly.
- * This item may require periodic tightening.
- * If you are having difficulty, our friendly is always here to help.







PREPARATION

- * Before beginning assembly of product, make sure all parts are present. Compare parts with part contents list and hardware contents list.
- * If any part is missing or damaged, do not attempt to assemble the product.
- * Estimated Assembly Time: 20 minutes.
- * Tools Required for Assembly (included): Allen Key

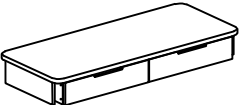
CARE AND MAINTENANCE

WOOD CARE: Adhesive felt pads should always be applied to areas of furniture which make direct contact with flooring, said application will prevent damage to the furniture and or surfaces on which the furniture lies. Objects placed on articles of furniture should rest on non abrasive material as to prevent damage to the wood finish. Wipe up spills immediately and avoid common hazards such as hot dishes, harsh solvents and abrasives. Cleaning should be done with a soft lint free cotton cloth dampened with water or furniture polish.

Part List and Hardware List

PIECE	DESCRIPTION	PICTURE	QTY
A	TABLE TOP		1x
B	LEFT LEGS		2x
C	RIGHT LEGS		2x
HW1	Hex Socket Bolt	 5/16"-18x1.25"	8x
HW2	ALLEN KEY M5	 5mm	1x
HW3	Anti-Tip Hardware		2x

Product Dimensions: 48"W x 20"D x 31"H

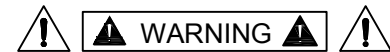
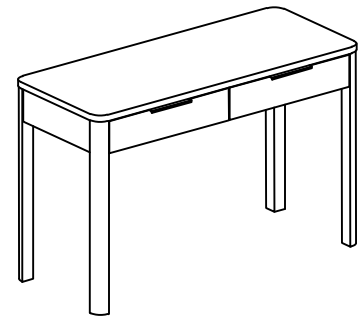

Weight Capacity : 25 lbs
Warning : Do not stand on the product
Warning : Do not over torque bolts

PREPARATION

- * Before beginning assembly of product, make sure all parts are present. Compare parts with part contents list and hardware contents list.
- * If any part is missing or damaged, do not attempt to assemble the product.
- * Estimated Assembly Time: 20 minutes.
- * Tools Required for Assembly (included): Allen Key

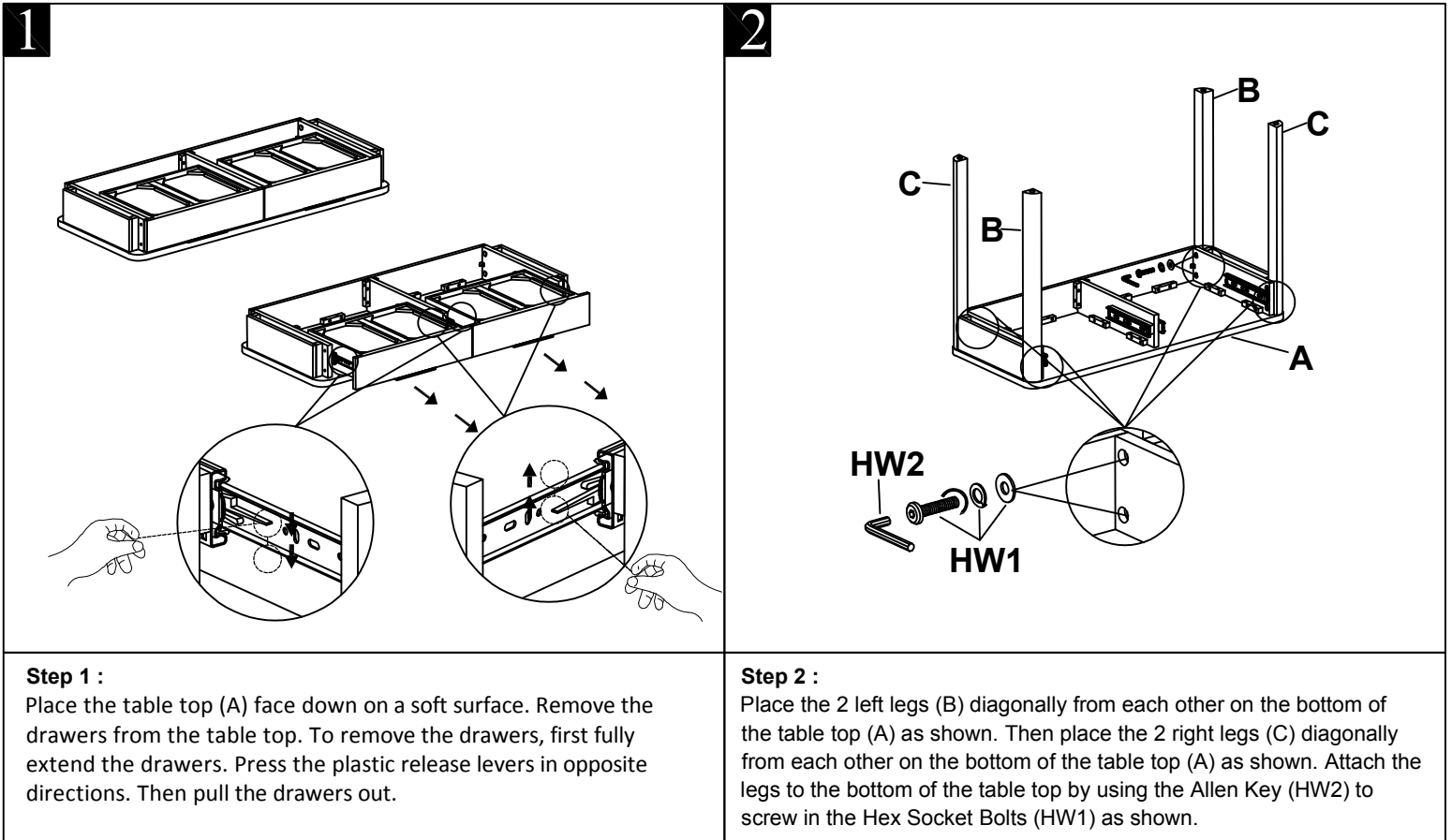

PREPARATION

- * Before beginning assembly of product, make sure all parts are present. Compare parts with part contents list and hardware contents list.
- * If any part is missing or damaged, do not attempt to assemble the product.
- * Estimated Assembly Time: 20 minutes.
- * Tools Required for Assembly (included): Allen Key

3

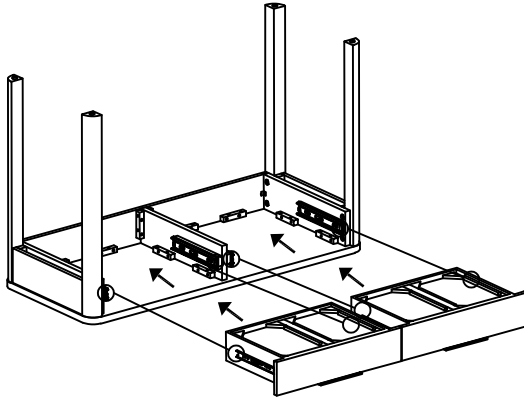

Step 3 :

Reinsert the drawers back into the table top (A). To reinsert them, first fully extend the slides from the table top. Move the ball bearing cage to the very front of the slides. Insert the metal rail on the drawer box into the front on the table top. Slide plastic guide receptacle. Once this is aligned on the both the left and the right sides of the drawer, gently push the drawer back into place. The drawer should insert smoothly. You may have to slide the drawer in and out several times in order to properly align the ball bearings, but minor resistance at the halfway point to two-thirds point is normal. If there is heavy resistance, remove the drawer and check.

4

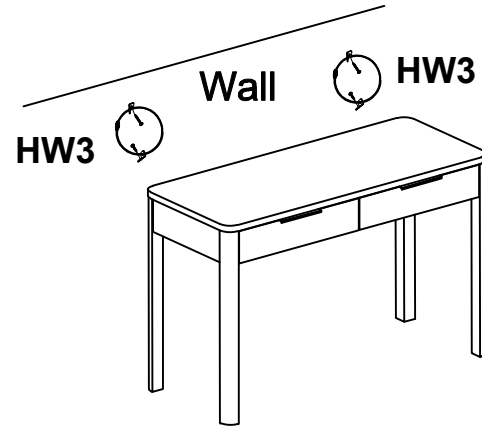

Step 4 :

Turn the assembled desk upright. Follow the installation instructions of the anti-tip hardware (HW3) to attach the desk to the wall. Assembly is now complete.