

Installation Instruction

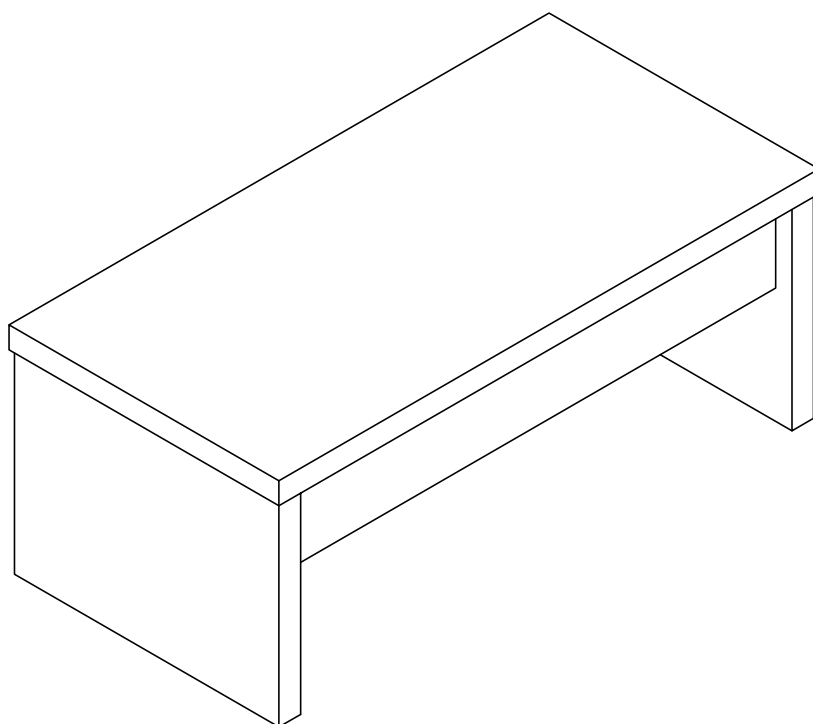

Assembling

What you need

- Use the packaging carton as a working surface to prevent product damage during assembly
- Phillips head screwdriver

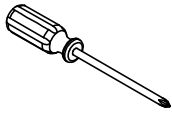

Weight Limitation

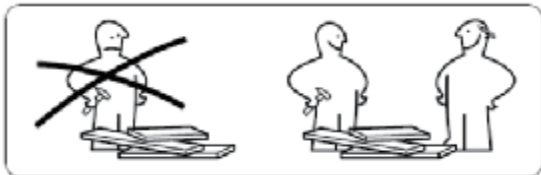

What' included

Code	Description	Qty
A	Cam Bolt M6X35MM	18
B	Cam Lock 15X9MM	18
C	Wooden Dowel M8X30MM	20
D	Screw M4X40MM	4
E	Hole position sticker	18
F	Left regulator	1
G	Right regulator	1
H	Screw M3.5X14MM	20
I	Foot nail	4
J	Wrench M4X55MM	1
K	Phillips screwdriver	1
L	Screw M6X25MM	2

The Hardwares

(A)

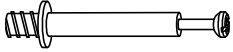

(B)

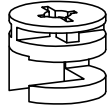

(C)

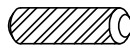

(D)

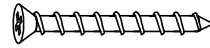

(E)

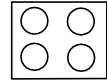

(F)

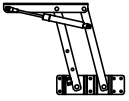

(G)

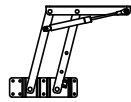

(H)



(I)



(J)



(K)



(L)



IMPORTANT:

1. Do not tighten bolts / screws completely until all bolts / screws are lined up and inserted into holes.
2. Do not over tighten screws and bolts to avoid stripping
3. Please use hand tools to assemble this product, you can also use power tools (please use power tools carefully)

Included Accessories

Code	Description	Qty
1	Panel	1
2	Laminate	1
3	Lateral plate	2
4	Anteroposterior plate	2
5	Right-side plate	1
6	Left side plate	1
7	Connecting pipe	1

The Accessoriess

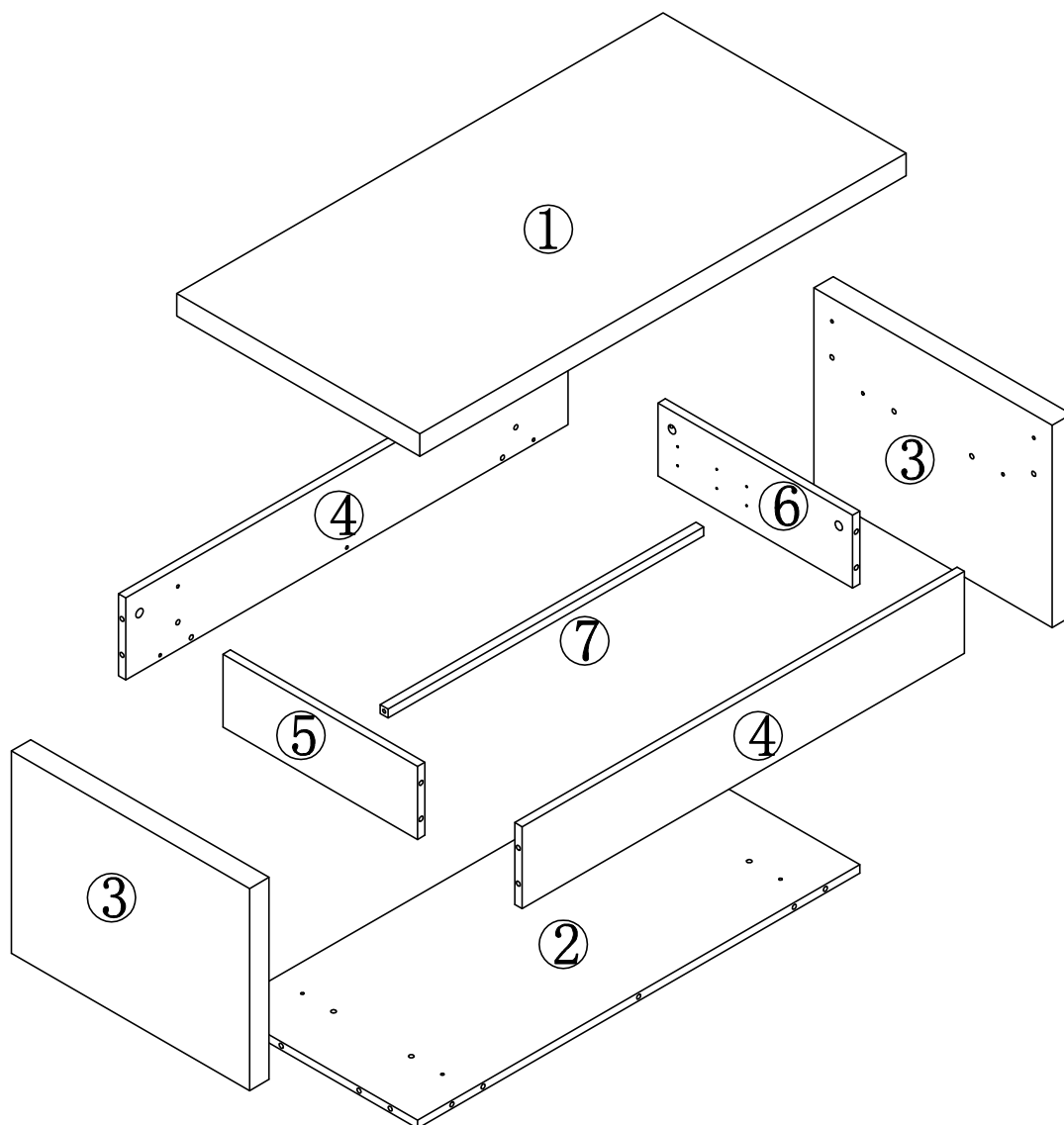

Step 1

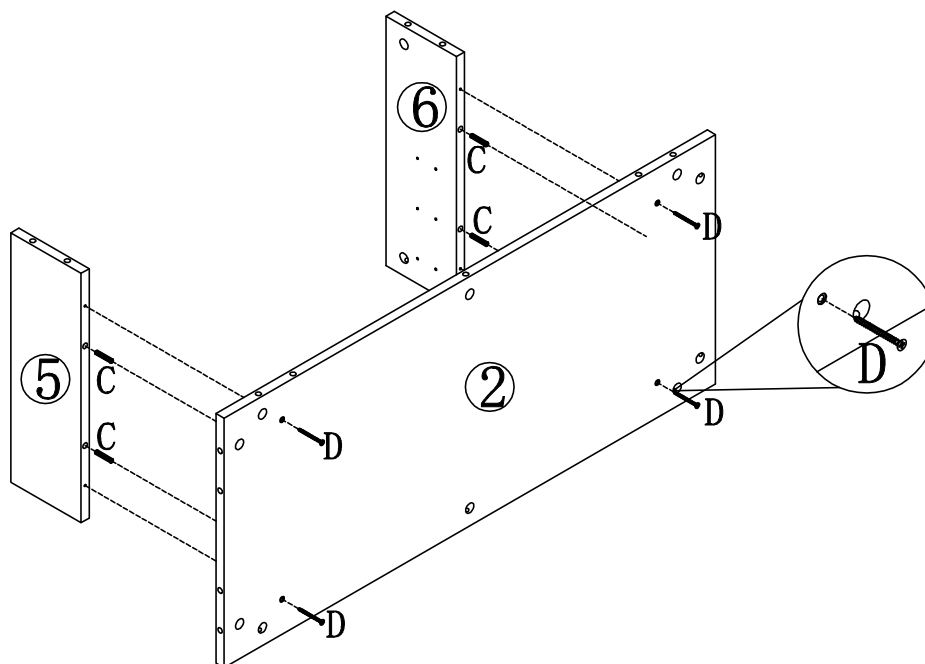
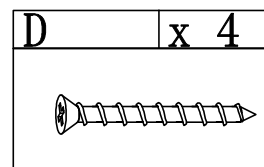
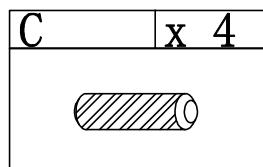

Step 2

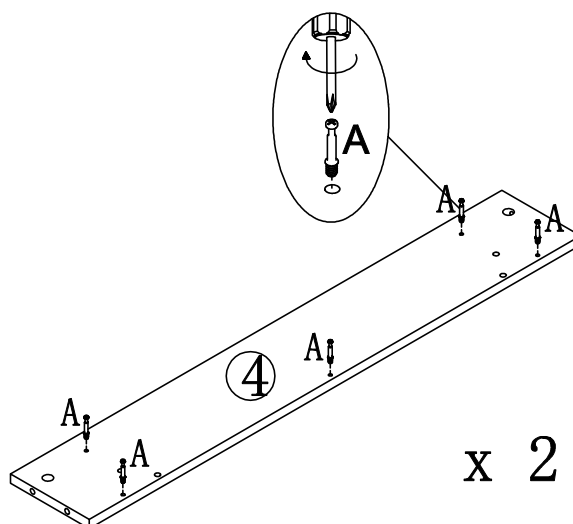
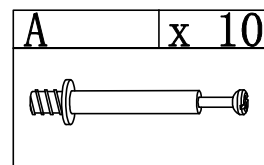

Step 3

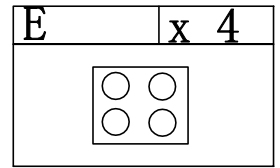
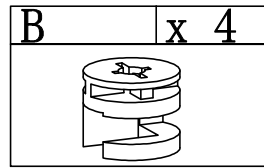
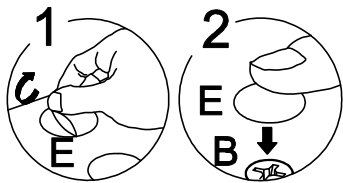
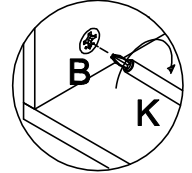
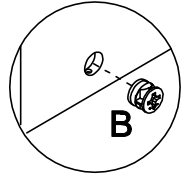
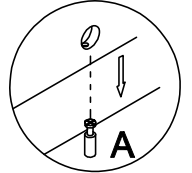
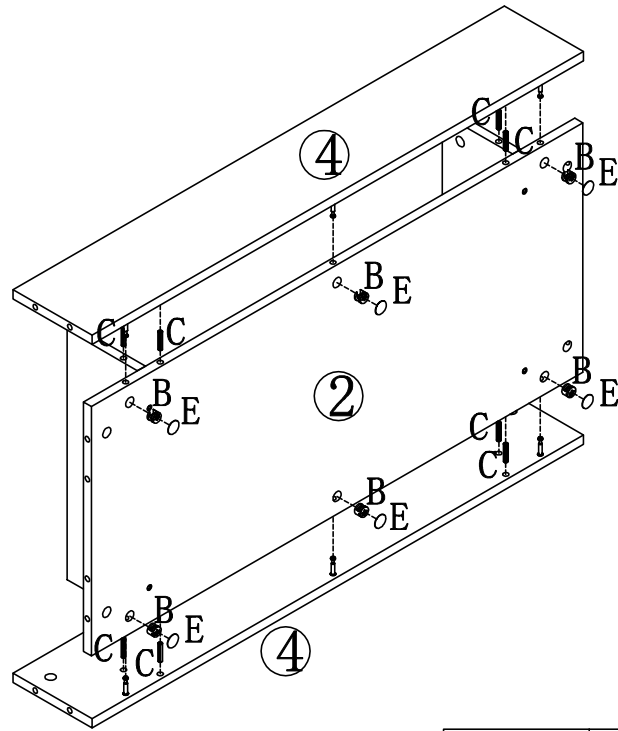
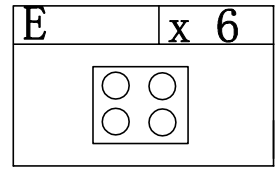
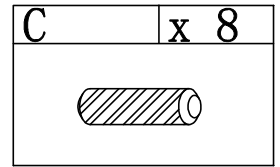
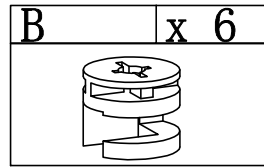

Step 4

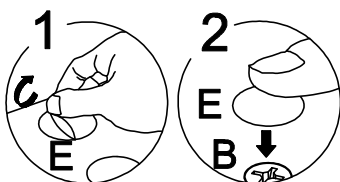
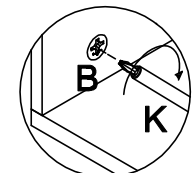
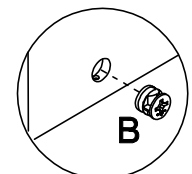
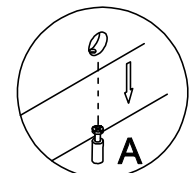
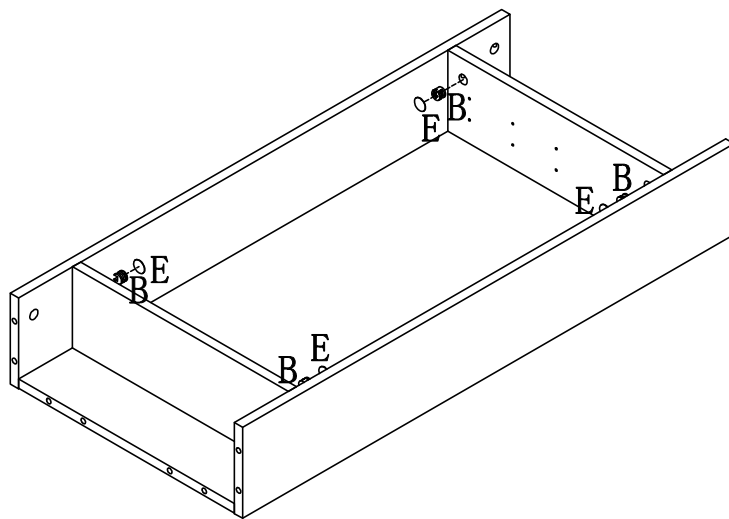

Step 5

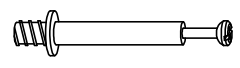
A	x 8
	

I	x 4
	

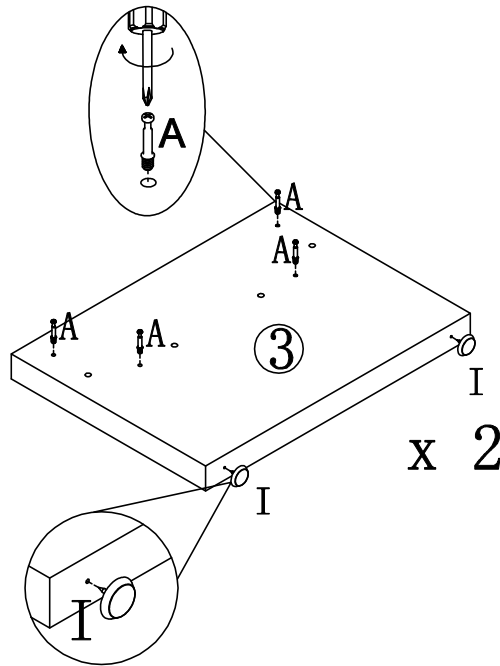

Step 6

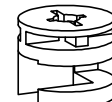
B	x 4
	

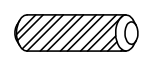
C	x 8
	

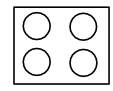
E	x 4
	

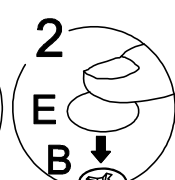
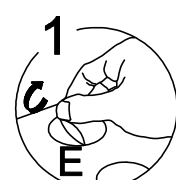
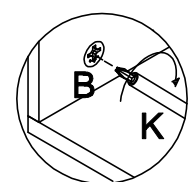
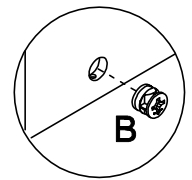
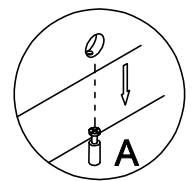
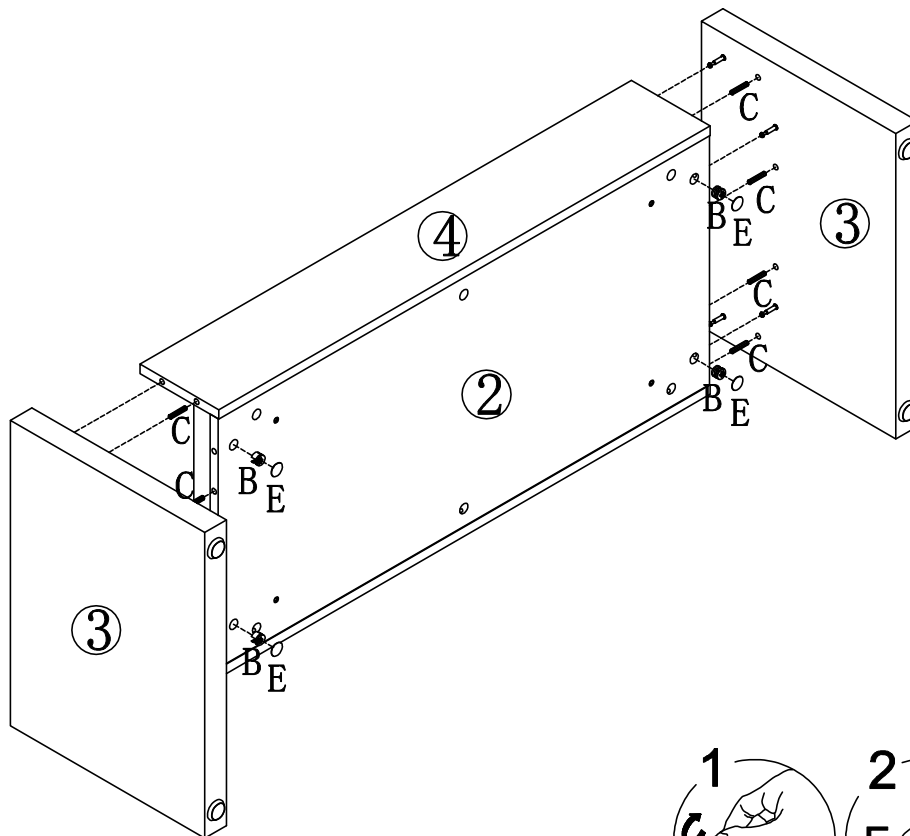

Step 7

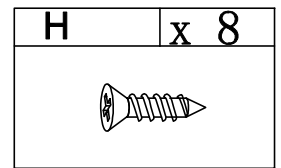
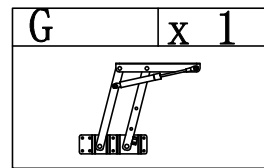
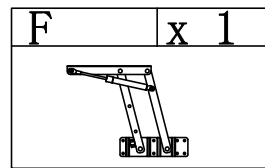
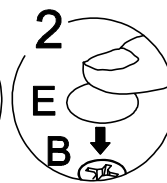
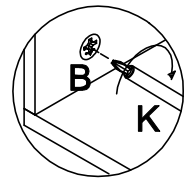
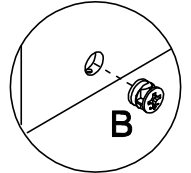
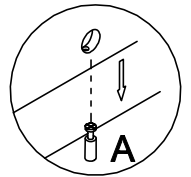
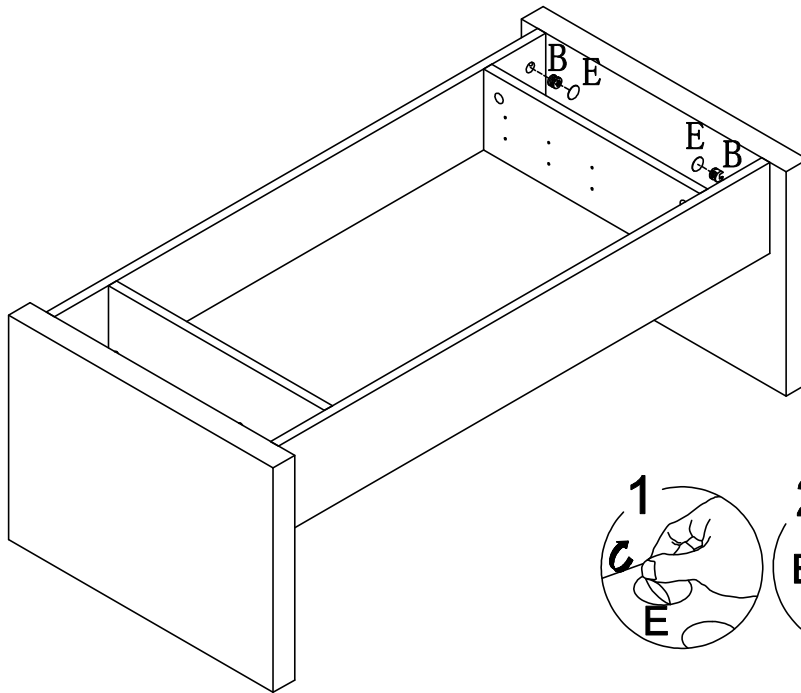
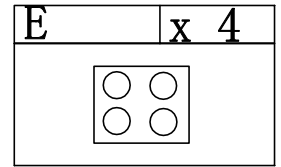
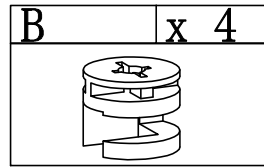

Step 8

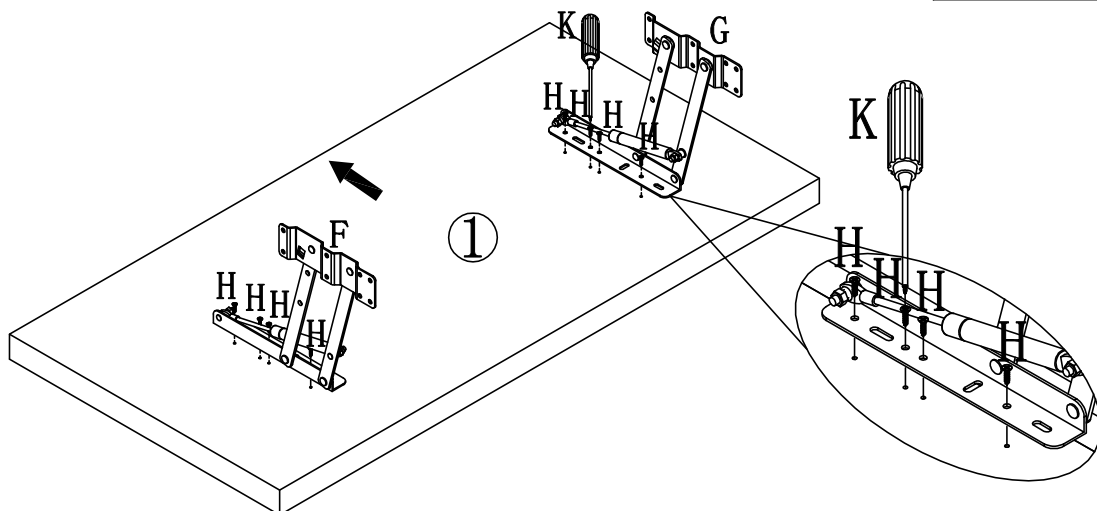
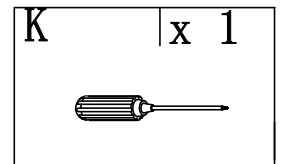

Step 9

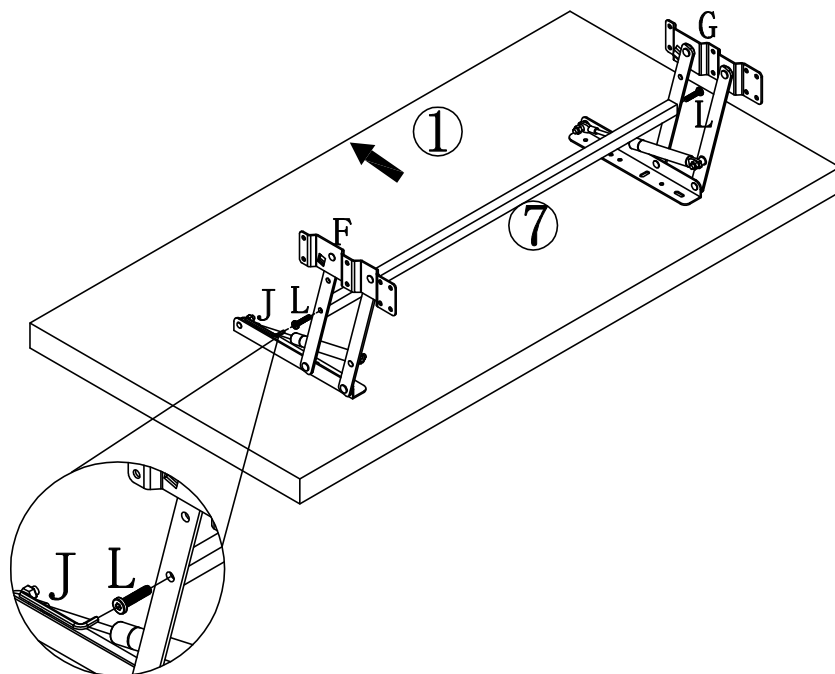
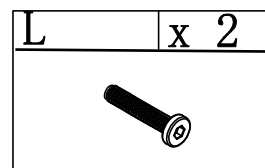
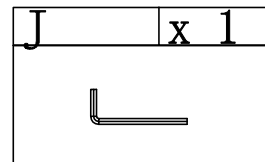

Step 10

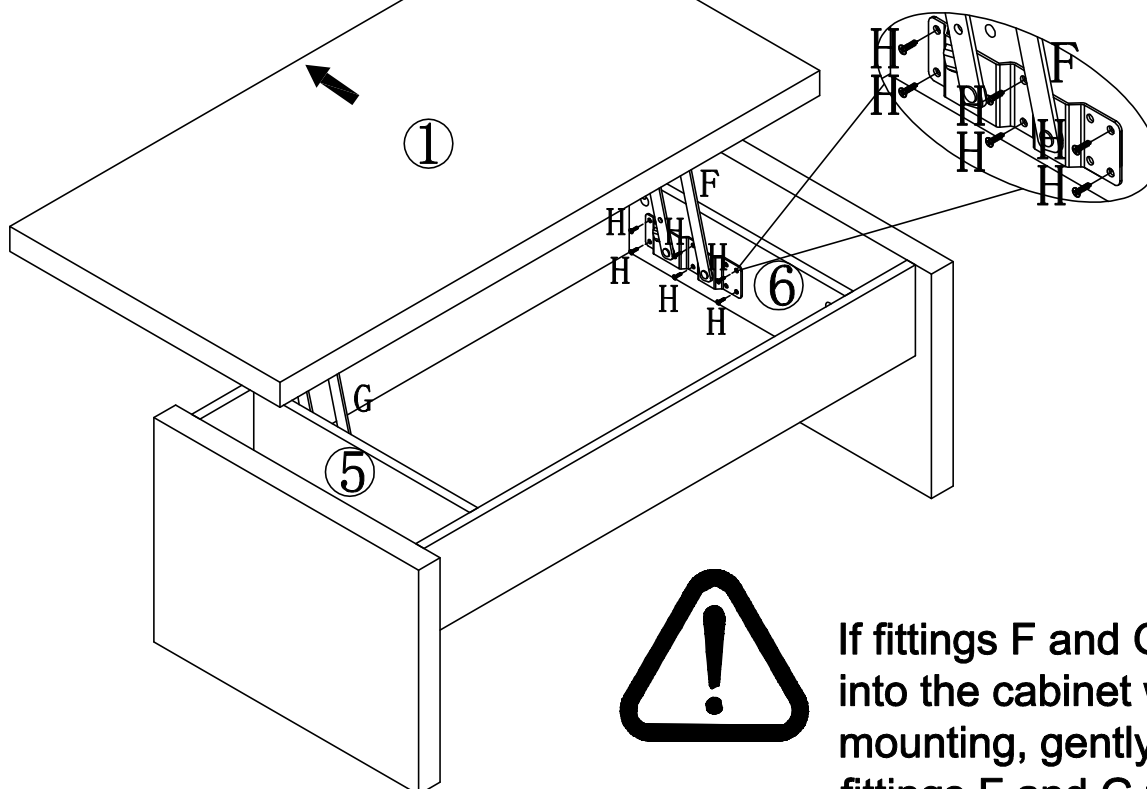
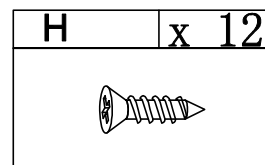

If fittings F and G cannot fit into the cabinet when mounting, gently squeeze fittings F and G to fit into the cabinet

Step 11

