

EXTENDING DINING TABLE ASSEMBLY INSTRUCTIONS

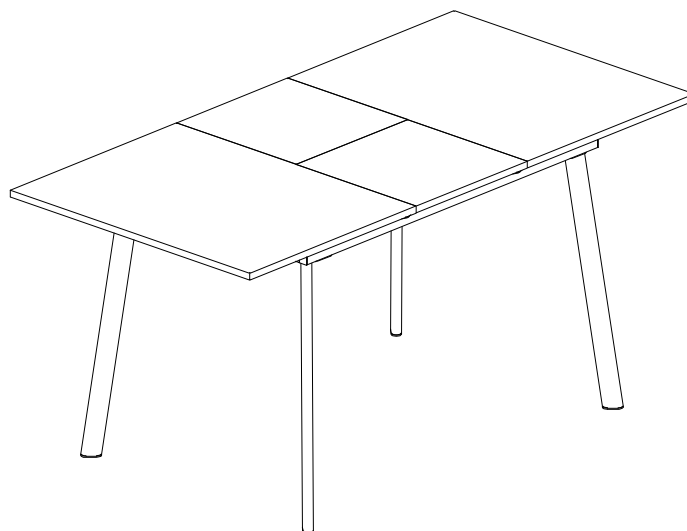

IMPORTANT FOR DOMESTIC USE ONLY PLEASE READ BEFORE YOU CONTINUE FURTHER

THE PRODUCT YOU HAVE PURCHASED WILL GIVE YOU MANY YEARS OF SERVICE IF YOU FOLLOW THE GUIDELINES FOR ITS SAFE ASSEMBLY AND PERIODIC MAINTENANCE AND CLEANING.

DO NOT USE ANY TOOLS OTHER THAN THOSE SHOWN.

ANY SPANNERS OR ALLEN KEYS REQUIRED ARE INCLUDED WITH THE FITTINGS KIT.

DO NOT FOR ANY REASON USE A POWER TOOL TO ASSEMBLE THIS PRODUCT. ITS USE WILL INVALIDATE ANY CLAIM YOU MAY HAVE AND COULD MAKE THIS PRODUCT UNSAFE .

DEPENDING ON THE AMOUNT OF USE THIS PRODUCT RECEIVES IT MAY BE NECESSARY TO TO TIGHTEN UP THE FIXINGS FROM TIME TO TIME, THIS IS COMPLETELY NORMAL FOR ANY FLATPACK FURNITURE.



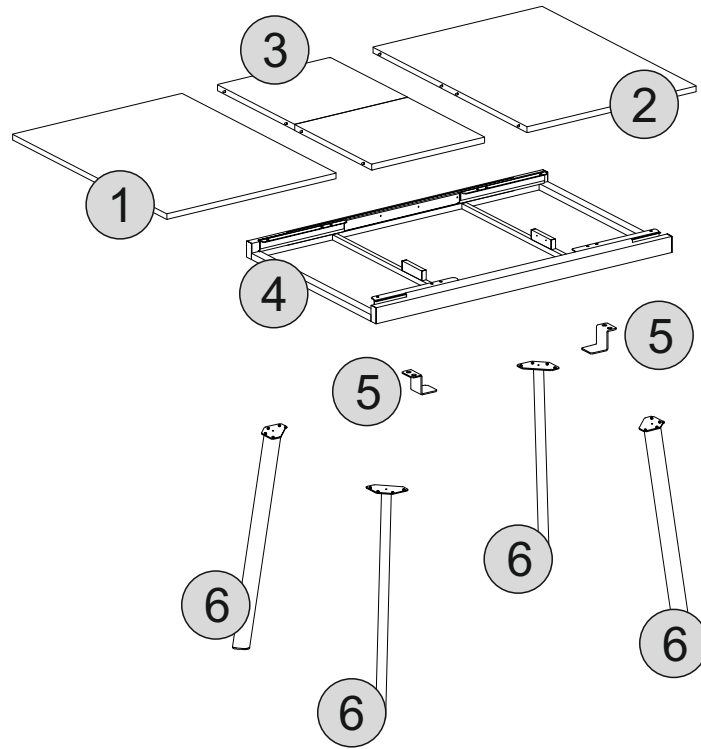



FOR CLEANING, YOU MAY USE A DAMP CLOTH (NOT WET) DO NOT USE POLISH, DETERGENT OR CHEMICAL CLEANERS.



PARTS LIST

Part Number	Part Code	Part Description	Quantity
1	S400-403-055-WJ1-01	Left Table Top	1
2	S400-403-055-WJ1-02	Right Table Top	1
3	S400-403-055-WJ1-03	Middle Table Top	1
4	S400-403-055-WJ1-04	Metal Frame	1
5	S400-403-055-WJ1-05	Iron Plate	2
6	S400-403-055-WJ1-06	Leg	4

HARDWARE LIST

REF		HARDWARE NAME	QTY
A		60*56*33mm	2PCS
B		55*30*13mm	4PCS
C		31*21*7mm	4PCS
D		M6*12mm	32PCS
E		Ø4*12mm	26PCS
F		4mm Allen Key	1PC

PLEASE CHECK THAT YOU HAVE ALL THE PARTS LISTED BEFORE YOU START ASSEMBLING. IF YOU DO FIND THAT SOMETHING IS MISSING, DO NOT CONTINUE ASSEMBLY. PLEASE CONTACT YOUR SUPPLIER IMMEDIATELY.

STEP 1

PARTS REQUIRED

4 - METAL FRAME x1

HARDWARE REQUIRED

A  02

E  04

TOOLS REQUIRED

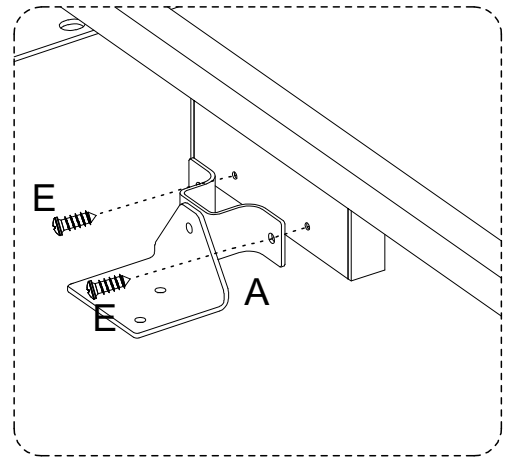
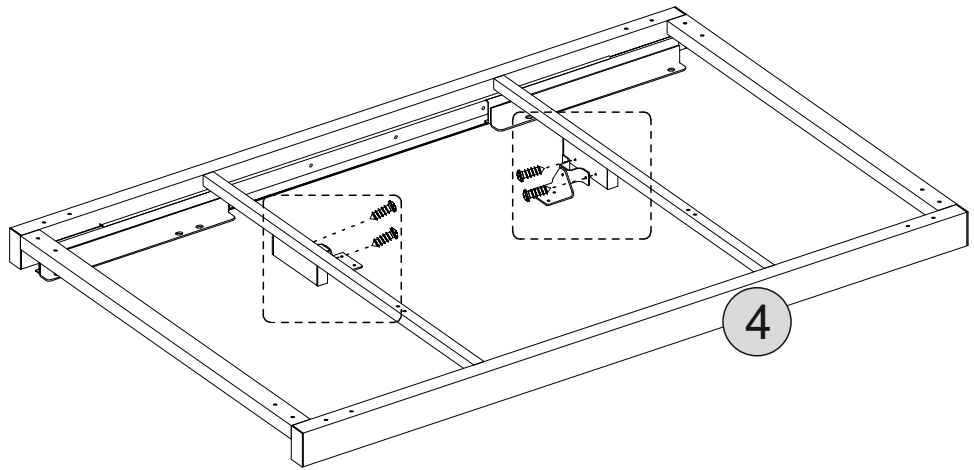
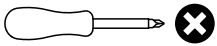

STEP 2

PARTS REQUIRED

1 - LEFT TABLE TOP x1

2 - RIGHT TABLE TOP x1

3 - MIDDLE TABLE TOP x1

HARDWARE REQUIRED

B  04

C  04

E  16

TOOLS REQUIRED

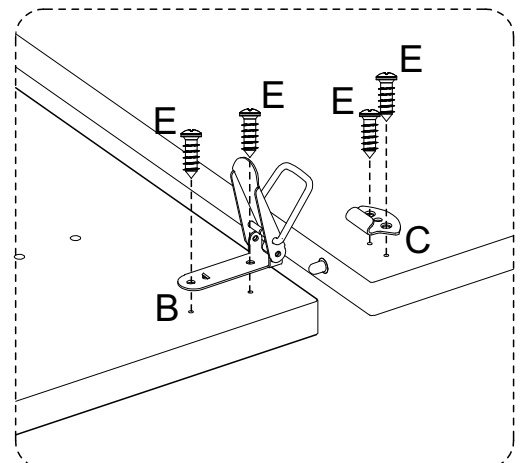
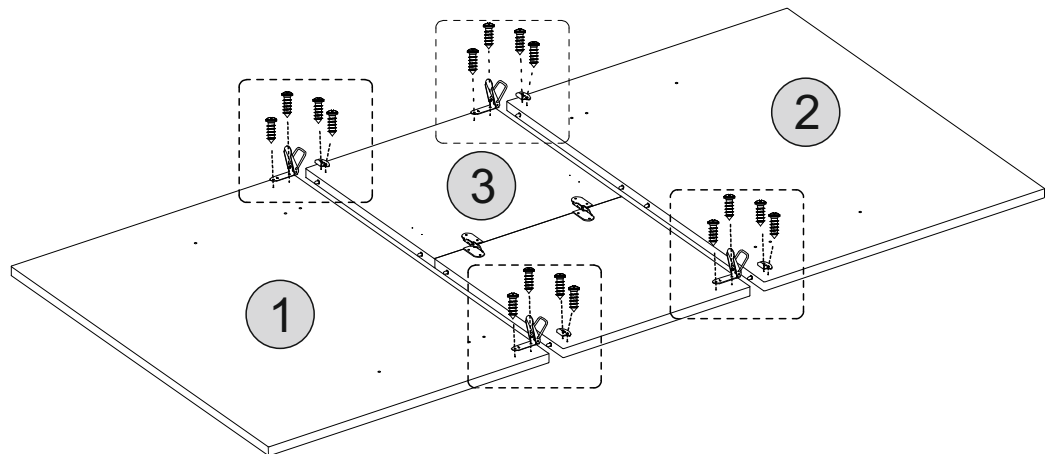

STEP 3

PARTS REQUIRED

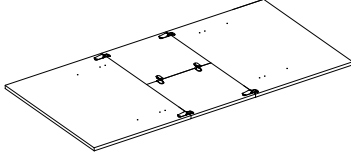
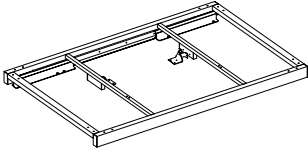

HARDWARE REQUIRED

D		12
E		06

TOOLS REQUIRED

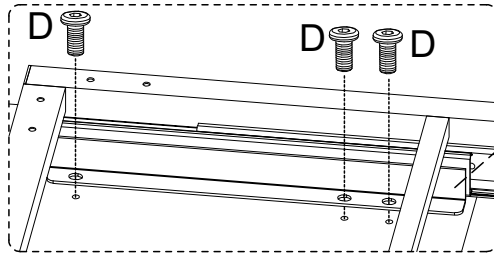
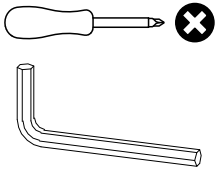

SLIDE THE FRAME TO LINE UP THE HOLES FOR BOLT (D) TO BE FIXED.

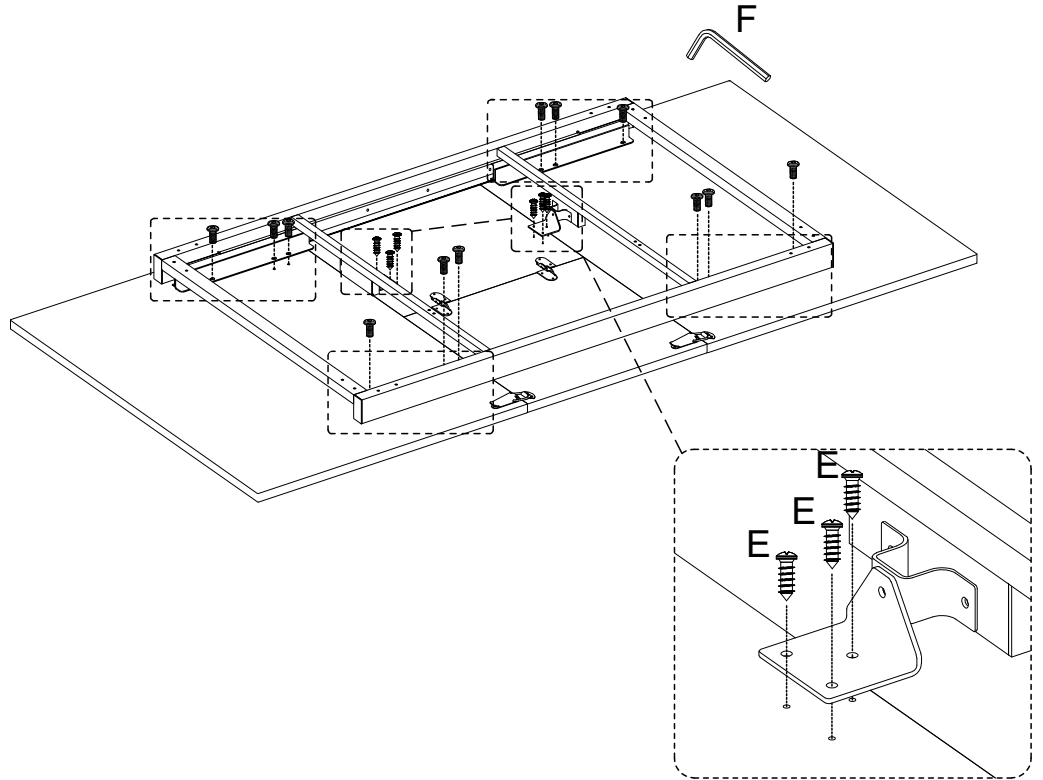

STEP 4

PARTS REQUIRED

5 - IRON PLATE	x2
----------------	----

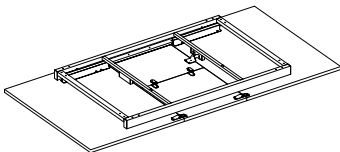

HARDWARE REQUIRED

D		04
---	--	----

TOOLS REQUIRED

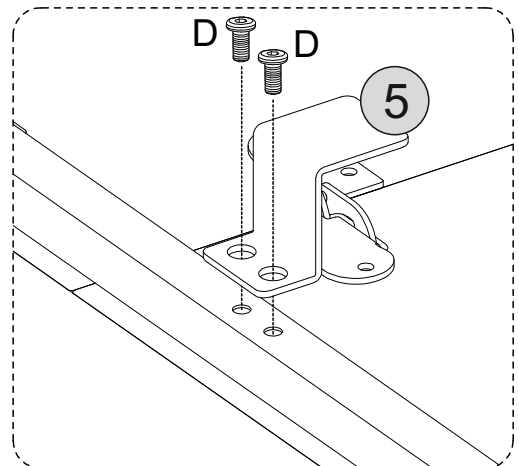
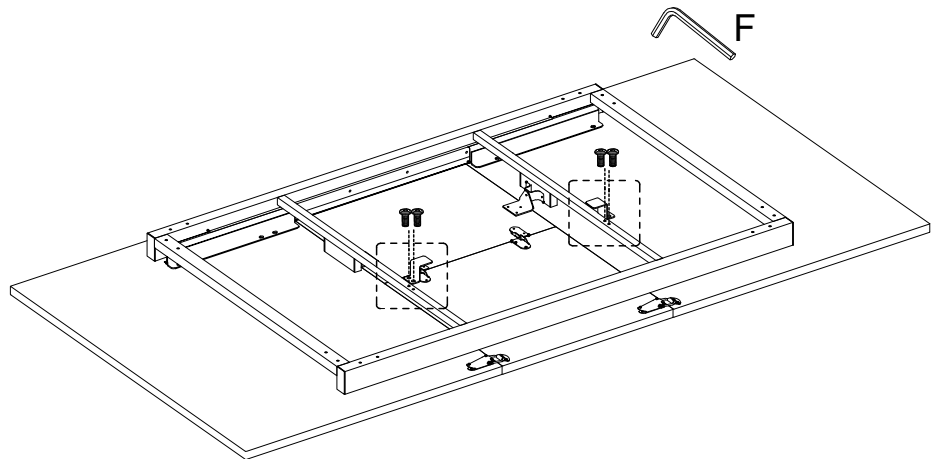

STEP 5

PARTS REQUIRED

6 - LEG x4

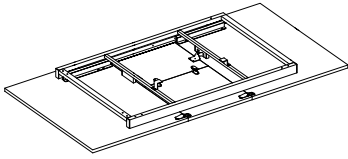

HARDWARE REQUIRED

D 16

TOOLS REQUIRED

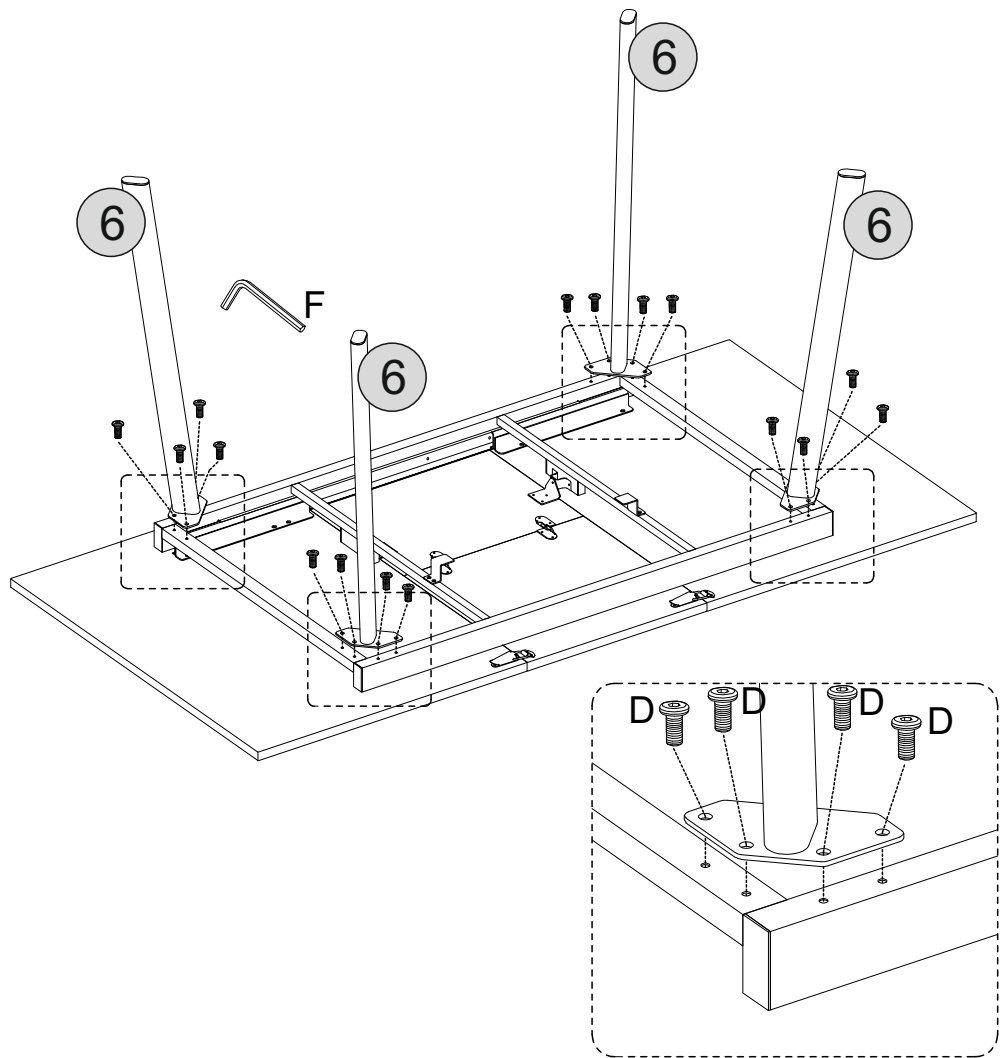
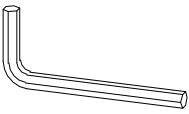

STEP 6

PARTS REQUIRED

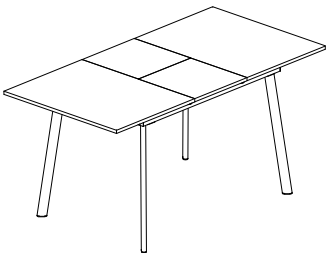

HARDWARE REQUIRED

TOOLS REQUIRED

