

**IMPORTANT NOTE:**  
 -Please keep all hardware parts out of the reach of children.  
 -Two or more people are needed for assembly.

# ASSEMBLY INSTRUCTIONS

## 66" LEG TABLE

Thank you for purchasing this quality product. Be sure to check all packaging materials carefully for small parts that may have come loose inside the carton during shipment.



**CAUTION :** Please read instructions thoroughly before unpacking assembly parts. Sharp, exposed staple tips can cause injury, therefore, for your protection, please remove any exposed staples used in packing.

1. We recommend that you should assemble this product with assistance of another person, this will make assembly easier, and will help to eliminate damage to the product or injury to persons during assembly.
2. Be sure to check all packing material carefully for small parts that may be come loose inside the carton during shipment.
3. Please do not over tighten screws or bolts.
4. Please put all the parts on a non- abrasive floor before assembly, and follow the assembly steps to assemble your newly purchased product correctly and efficiently.

Reminders :

- Use only hardware supplied.
- This item may require periodic tightening.

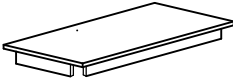
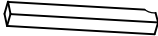
### PARTS LIST

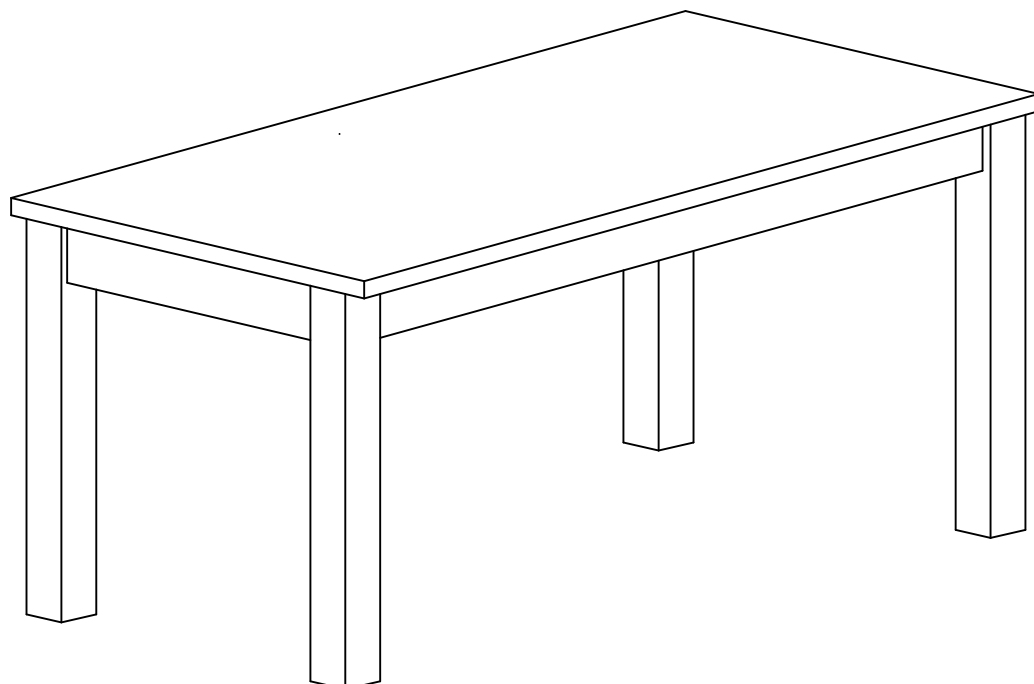

NO.	FIGURE	DESCRIPTION	QTY
A		TABLE TOP	1 PC
B		LEG	4 PCS
C		HARDWARE KIT	1 PC



# ASSEMBLY INSTRUCTIONS

## 66" LEG TABLE

### HARDWARE PARTS :

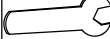
1	2	3	4
			
HEX BOLT 8PCS	LOCK WASHER 8PCS	FLAT WASHER 8PCS	WRENCH 1PC

#### STEP 1

Turn the Table Top upside down on a soft surface such as a carpet.  
Place the Leg (B) to corner of Apron, then tighten the Flat Washer (3),  
Lock Washer (2) and Hex Bolt (1) using the Wrench (4) provided. Repeat  
Step 1 for the remaining legs.

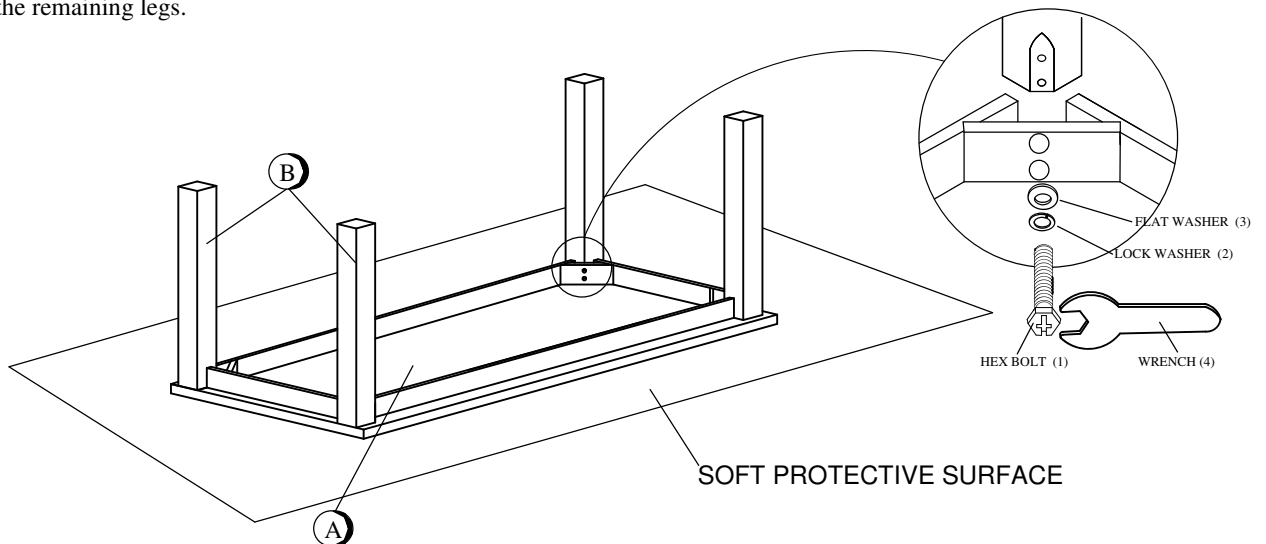

#### STEP 2

Turn the table to upright position.  
Assembly is now complete.  
Thank you for purchasing this product.

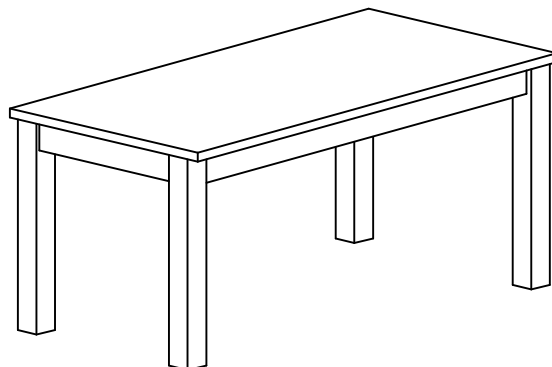

#### CARE INSTRUCTION

- ~ Be sure to use the same type of polish consistently.  
Your furniture will appear cloudy or streaky if oil based or wax are interchanged.
- ~ Spray your furniture surface evenly. Wipe in a circular motion with a soft clean cloth.