

Sofa

Assembly Instruction – Please keep properly for future reference.

If you find any missing boxes, damaged parts, or accessory shortages, please contact the customer service team of your purchasing channel immediately. We will resolve the issue as quickly as possible.

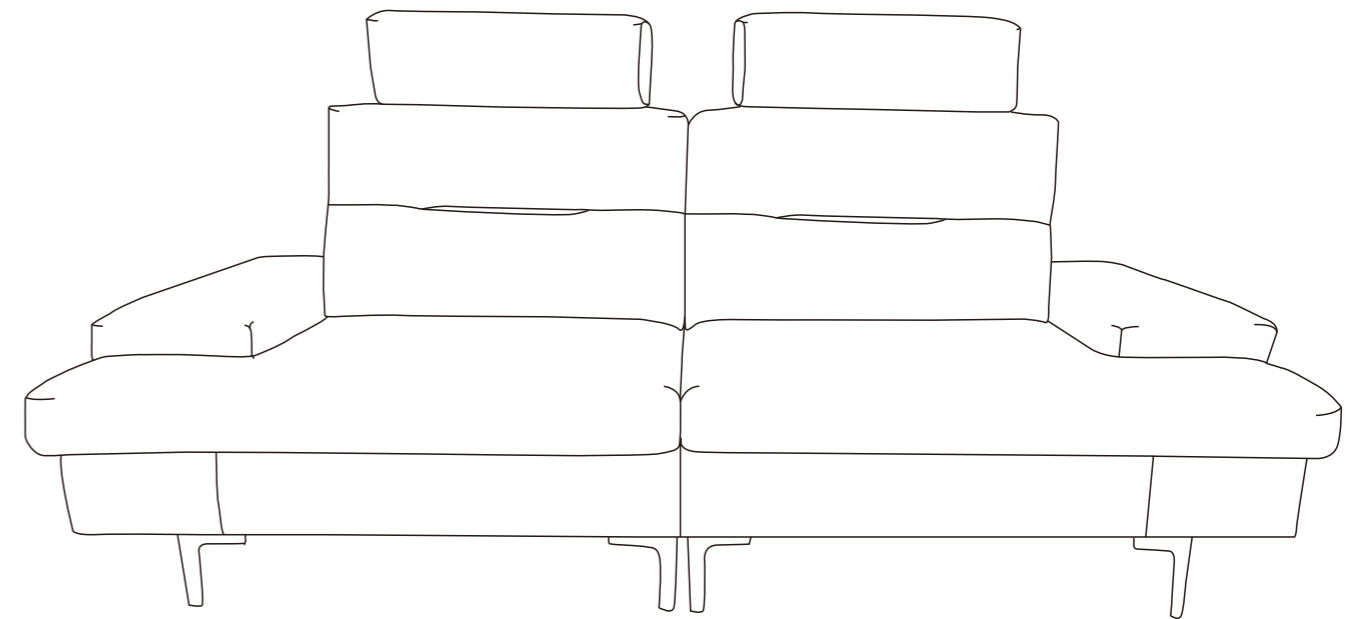

THE FOLLOWING INFORMATION:

- Order number
- Purchase platform
- Purchase date
- Detailed description of the issue along with photos (if applicable)

Important – Please read these instructions carefully before starting the installation.

Before Assembly



Thank you for choosing our product!

To ensure a smooth installation process, please read this guide carefully to familiarize yourself with the required tools, materials, and installation steps.

Follow the relevant sections to avoid any damage caused by improper installation, and make sure to review all operation and safety guidelines for correct installation procedures.

Packaging Notice:

1. Multi-Box Shipping Notice

This product is packaged in 4 separate boxes for shipping and may arrive in batches at different times. To ensure a smooth assembly process, please make sure all boxes are received before unpacking and starting the installation.

2. Box and Packaging Verification

Each box is labeled with a corresponding number. Please refer to the packing list on the next page of this manual to verify that all boxes have been received.

If you find any missing boxes, damaged parts, or accessory shortages, please contact the customer service team of your purchasing channel immediately. We will resolve the issue as quickly as possible.

Installation Information

- All information in this guide is based on the product's condition at the time of printing. We reserve the right to modify product features, packaging, or availability without prior notice.
- Before installing the furniture, ensure that all necessary electrical or environmental preparations are completed.
- This manual contains important instructions on installation, cleaning, and maintenance. Please read it thoroughly and keep it for future reference.

Pre-Installation Checklist

1. Carefully inspect the new product for any damage or defects.
2. Ensure installation is carried out on a clean, flat surface to maintain balance and stability.

3. Avoid prolonged exposure of the product to damp environments or direct sunlight.
4. Handle with care during installation. Use protective materials (e.g., soft pads) to prevent scratches.
5. For any questions or technical support, refer to the customer service guide and contact the seller's customer service.

Usage and Maintenance Recommendations

1. Clean furniture regularly to maintain hygiene and prevent bacteria growth. Use a damp cloth that has been wrung out to avoid scratching the finish.
2. Avoid contact with acidic or alkaline corrosive liquids.
3. Do not use unauthorized replacement parts. For replacement parts, contact the manufacturer or distributor.
4. Do not machine wash or rinse any part of this product with water.



Safety Warnings

1. Warning Labels:

Do not remove warning labels on the product or packaging, and always follow the related instructions.

2. Regular Inspections:

Regularly check all parts of the product to ensure they are correctly installed, undamaged, and all connectors are securely tightened.

3. Safe Use:

Do not play on or under the sofa, and strictly avoid jumping or any actions that may harm the sofa or users.

4. Rope Hazard:

Do not attach ropes, hooks, straps, or other unintended items to any part of the product.

5. Guide Preservation:

Retain this manual for future reference.

6. Supervisory Responsibility:

Safety is a shared responsibility between the manufacturer and the user. Always adhere to safety guidelines when using the product.

Disclaimer

We are committed to providing safe and reliable products. If you have any questions about this product or require additional support, please contact our customer service team. We are here to assist you.

Customer Service Guide



Thank you for choosing our product! We are committed to providing you with excellent service. If you find any missing parts, damaged packaging, or product damage after receiving all packages, please follow the steps below to quickly contact our customer service team. We will do our best to resolve your issue.

1. Missing Parts

Verify Parts:

1. Refer to the “Parts List” in the manual to verify the name, specifications, and quantity of the missing parts.
2. Take a clear photo of the parts list and mark the missing parts with detailed information, e.g., “Missing 5 pieces of M6×30mm screws.”

Contact Us:

- A description of the missing parts and a photo of the parts list.
- Order details (order number, purchase platform, purchase date).

2. Product or Packaging Damage

If it affects normal use:**Steps:**

1. Take clear photos or videos showing the damaged parts and the extent of the damage (multi-angle shots are recommended).

2. Email the photos/videos along with order details to with the subject line “Product Damage Issue.”

Resolution:

After verification, we will arrange for a replacement part, product exchange, or refund as quickly as possible.

If it does not affect normal use:**Steps:**

1. Contact our customer service team.
2. Provide a description of the damage and include relevant photos or videos.

Resolution:

We will provide repair guidance or an appropriate compensation plan based on the specific situation.

Helpful Tips

To process your issue efficiently, please prepare the following information:

- Order details (order number, purchase platform, purchase date).
- Clear photos or videos.
- We are committed to providing quick and professional solutions, no matter the size of the issue, to ensure your satisfaction.

**Thank you for your trust and support!
We hope you enjoy using our product!**

Parts List



Box 1

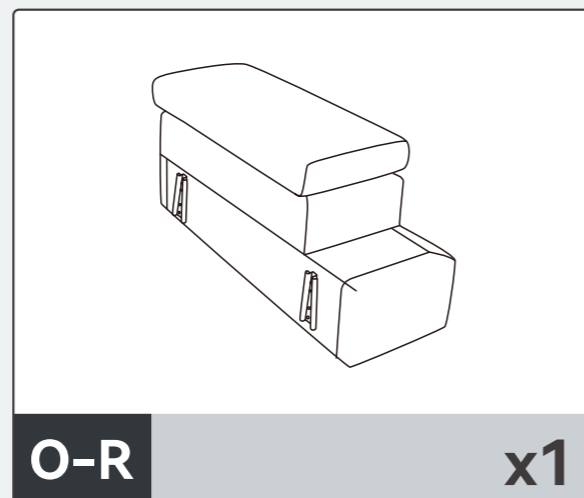
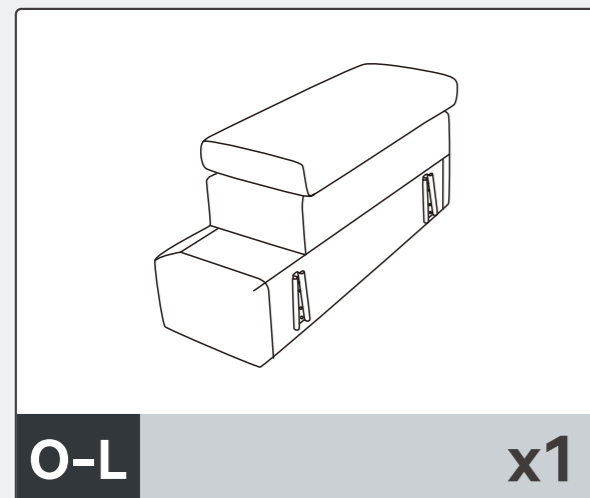

Hardware List (in Box 1)

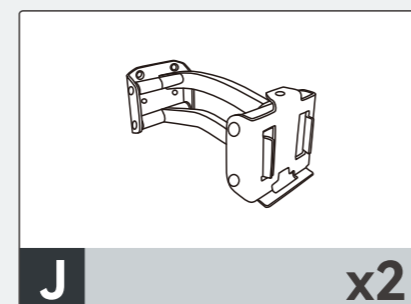
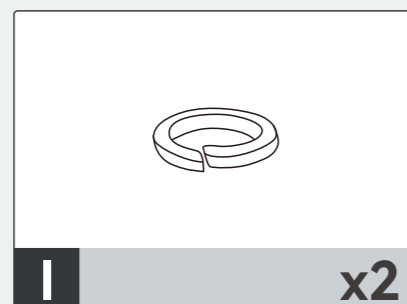
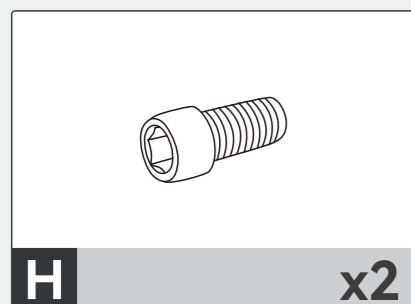
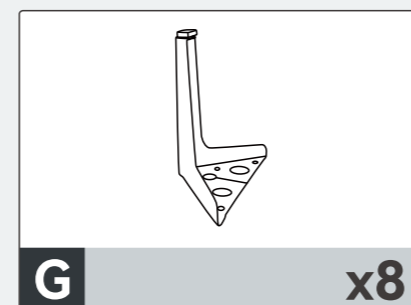
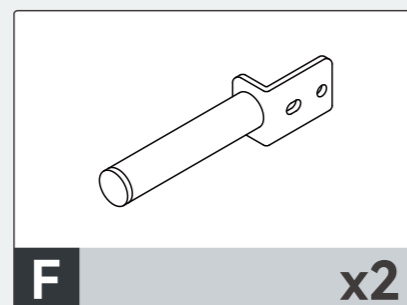
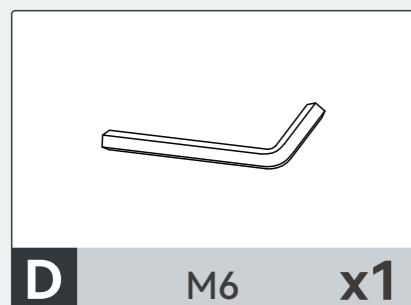
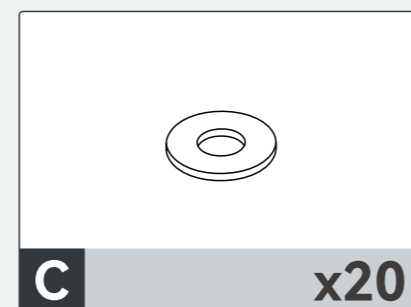
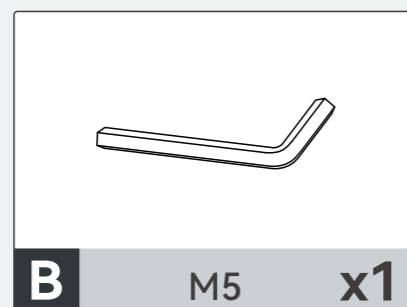
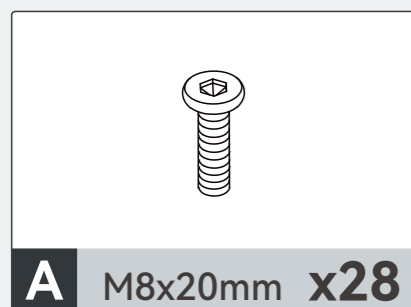

Box 2

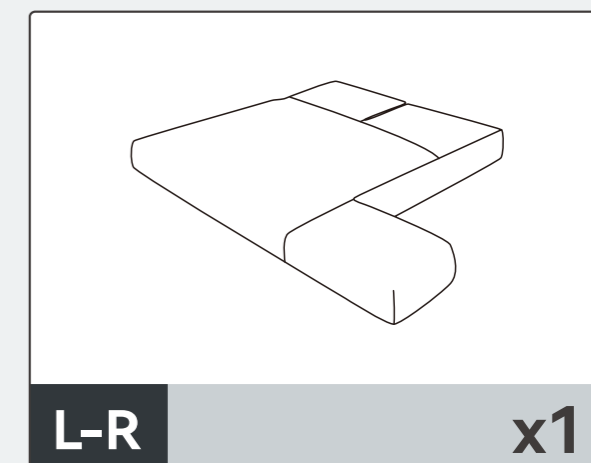
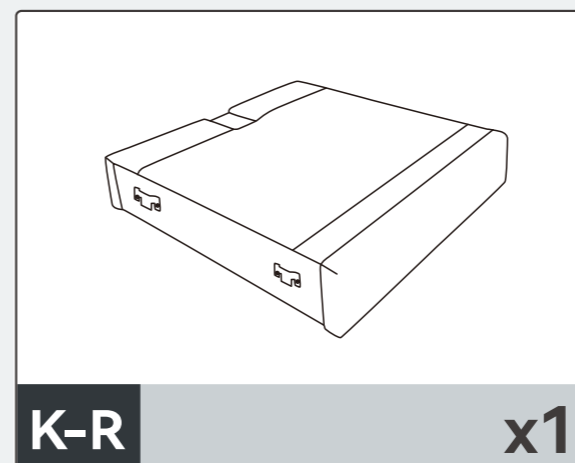

Box 3

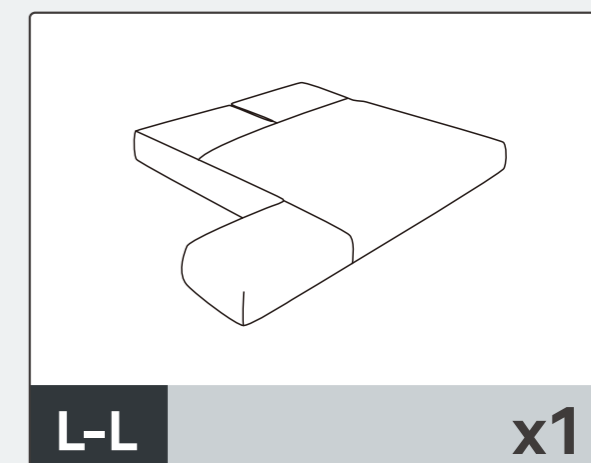
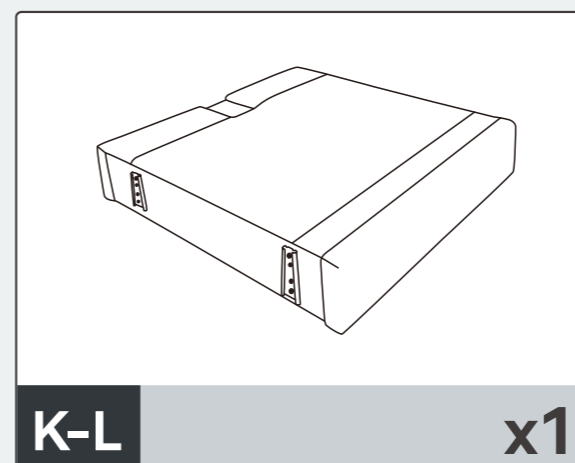

Box 4

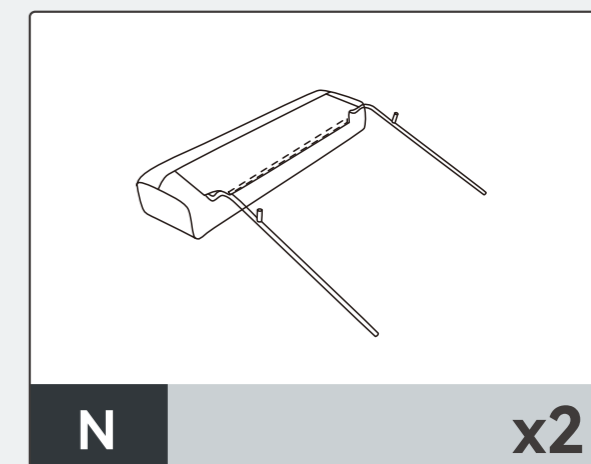
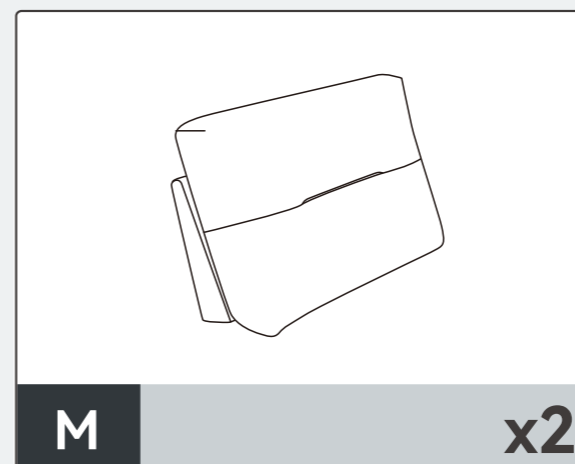

Assembly Instructions



Important : Please read these instructions fully before starting assembly.

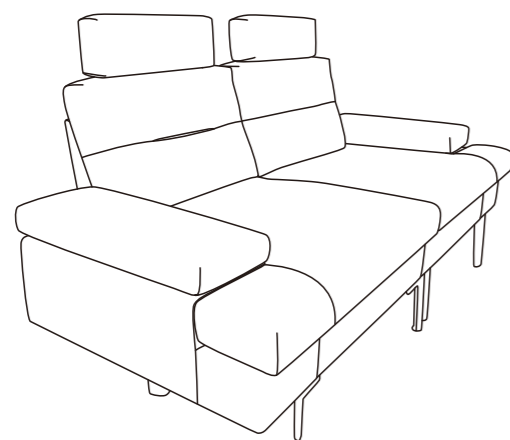

Note :

Delivered with **FOUR PACKAGES** with **FOUR TRACKINGS**, may **NOT** be delivered at the same time.

Before starting assembly, determine where the sofa will be placed and the orientation you want it to be.



2 people needed



Work gloves

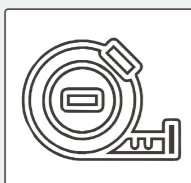

Tape measure

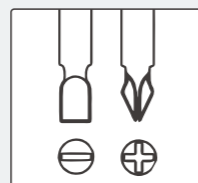

Other Tools Required
Phillips Screwdriver
(Not Included)

Simple Assembly Steps

1. Read the manual carefully.
2. Check all parts and hardware.
3. Prepare necessary tools.
4. Have at least two adults for assembly.

Please follow the instructions and use a sanitary napkin to protect the product during your assembly process.

Note:

1. The assembly should be done on a flat surface to maintain balance.
 2. Do not tighten the screws before the assembly is complete.
- To make the assembly process easier and better, two or more adults are needed.

Step 1

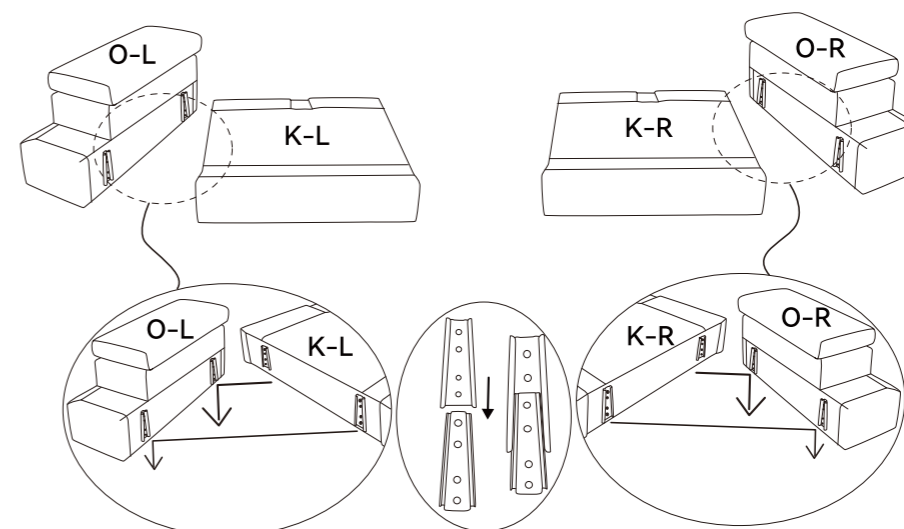

Align the (K-L) piece with the slot on the (O-L) component and insert it horizontally. Align the (K-R) piece with the slot on the (O-R) component and insert it horizontally. Ensure both are fully seated at the bottom.

Step 2

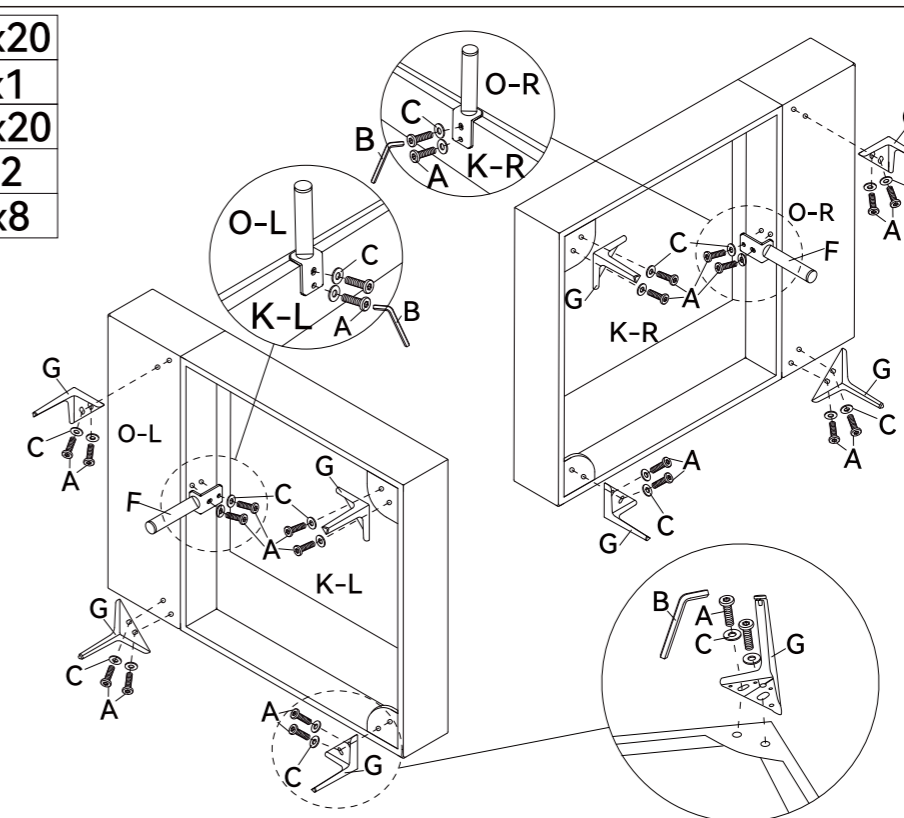

	Ax20
	Bx1
	Cx20
	Fx2
	Gx8



According to the direction shown in the diagram:

1. Align the metal foot (G) with the corresponding holes at the bottom of the (K-L)/(K-R) / (O-L)/(O-R) components. Secure it with screws (A) and (C). First screw them in by hand, then fully tighten all screws.
2. Tighten the metal center feet (F) and (E) to the center position at the bottom of the (O-L) and (O-R) components.

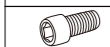
Step 3

	Dx1
	Hx2
	Ix2

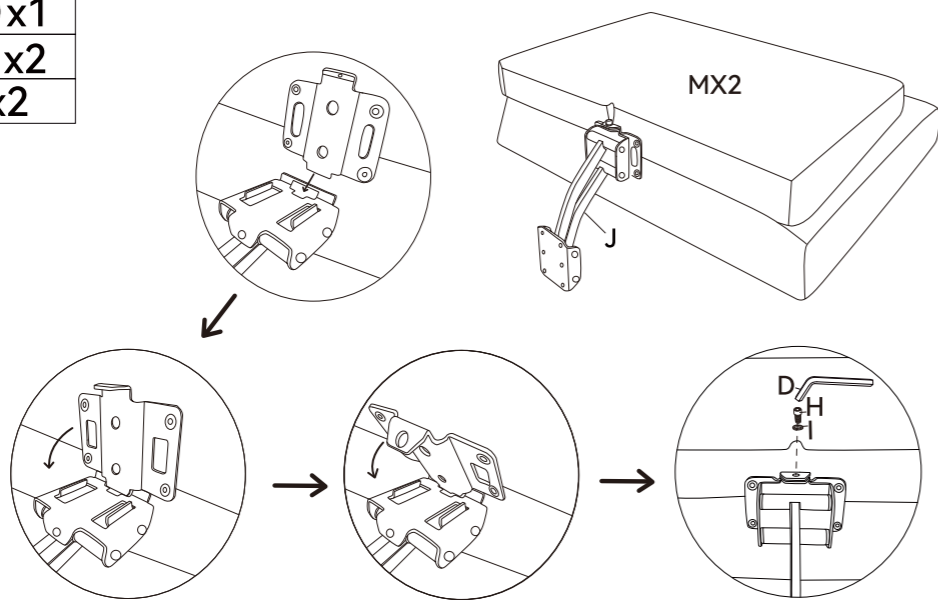

Following the steps, assemble the (J) component to the corresponding mounting holes of the bracket under the (M) component. Secure it with screws (H) and (I), and repeat the same operation for the other side.

Note: Pay attention to the front/back orientation of the hardware. First, hand-tighten all screws, then fully tighten all screws.

Step 5

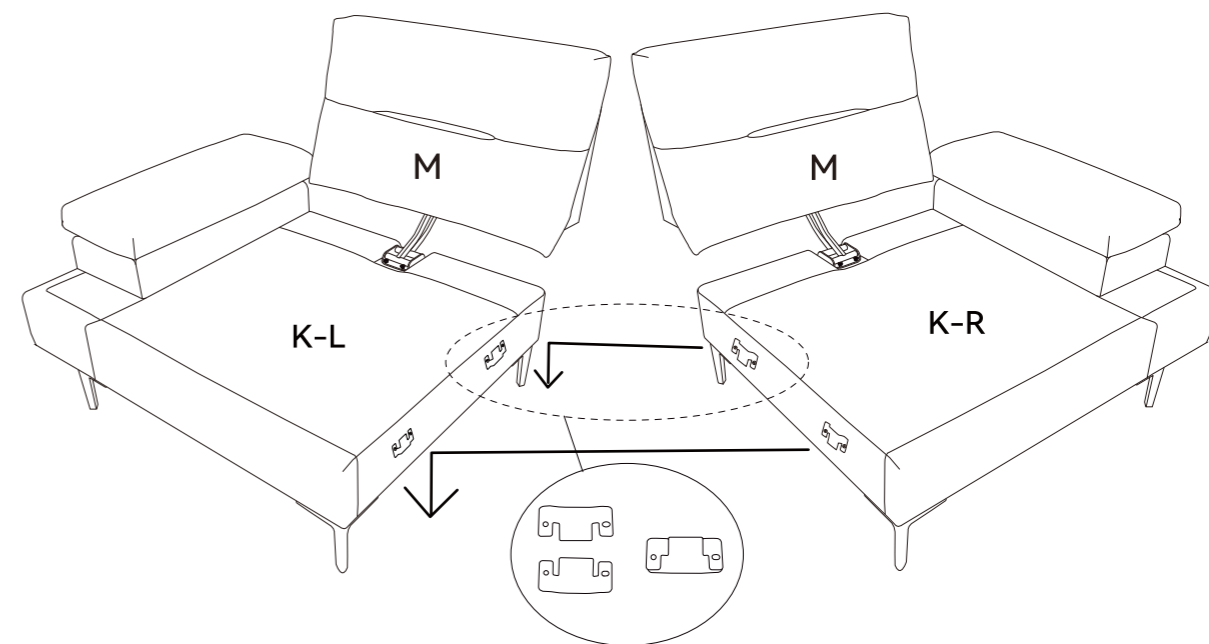

Insert the seat frame (K-R) into (K-L) and mount it horizontally.

Step 4

	Ax8
	Bx1

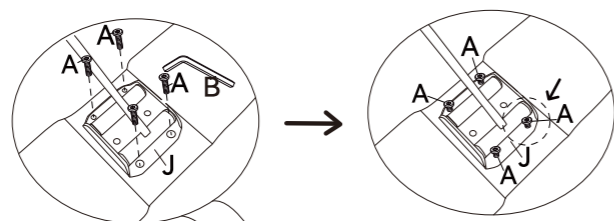

Screw doesn't need to be tightened so that adjustments can be made later.

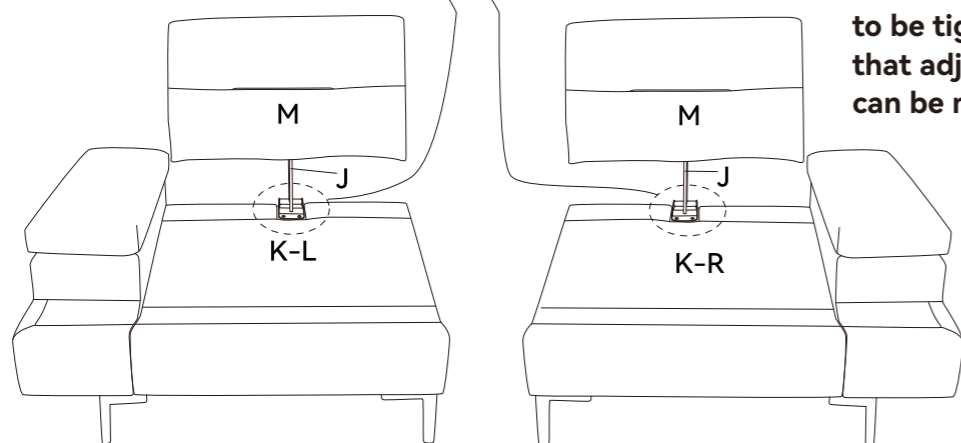

Assemble the (M) component to the corresponding holes on the (K-L) and (K-R) components, and secure it with screw (A).

Note: Pay attention to the front/back orientation of the hardware. First hand-tighten all screws, then fully tighten all screws.

Step 6

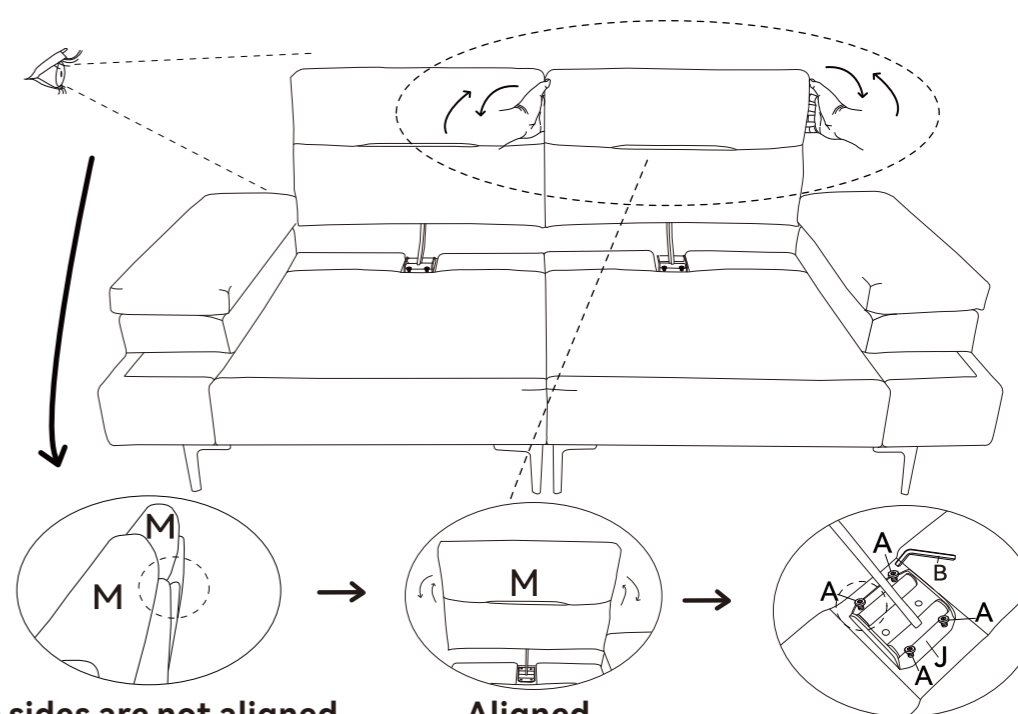

The sides are not aligned

Aligned

If the backrest is uneven after assembly, please adjust it as shown in the diagram: push the backrest (M) backward, then loosen screw (A) connected to hardware (J) by about twenty percent. Once the backrest (M) is aligned evenly, fully tighten screw (A) again.

Step 7

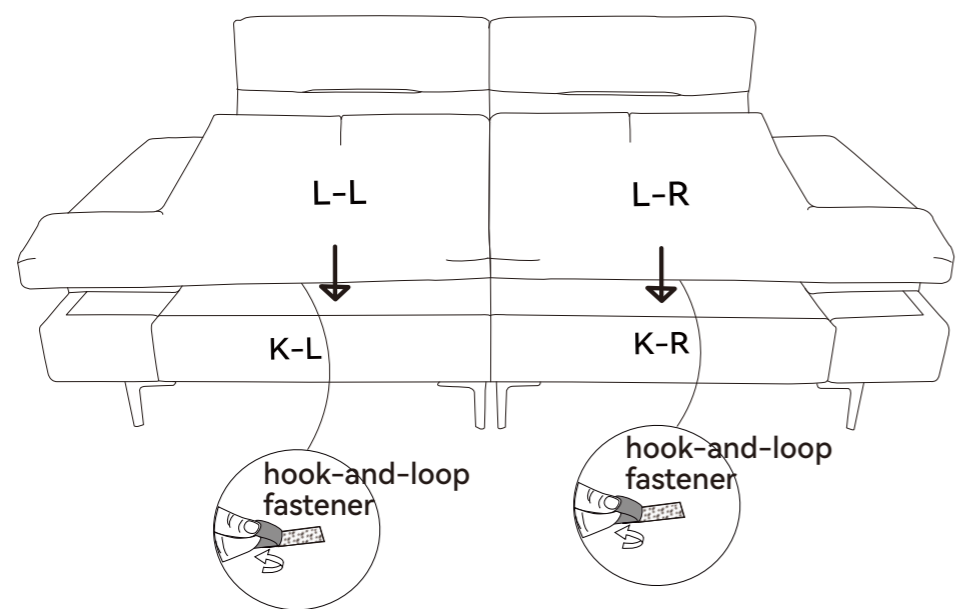

Place the seat cushion (L-L) onto the (K-L) seat frame, and the seat cushion (L-R) onto the (K-R) seat frame. First, peel off the hook-and-loop fastener on the front bottom of each cushion and press firmly to secure.

Note: Pay attention to the front/back orientation of the seat cushions.

Step 8

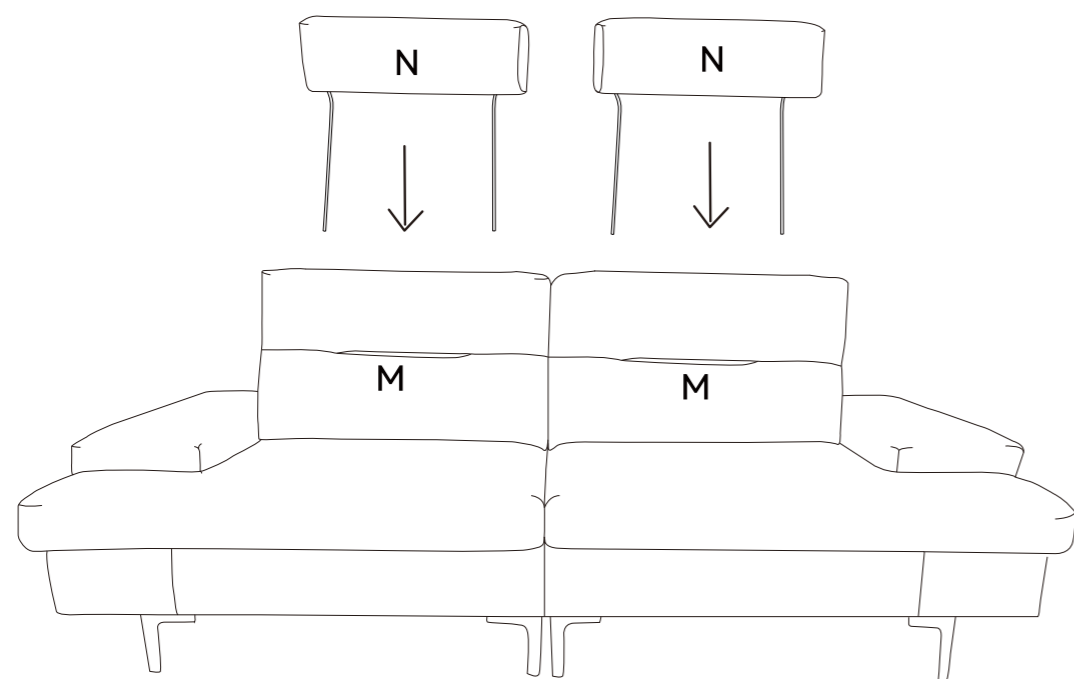

Align the (N) component with the slot on the back side of the (M) component and insert it horizontally.

Step 9

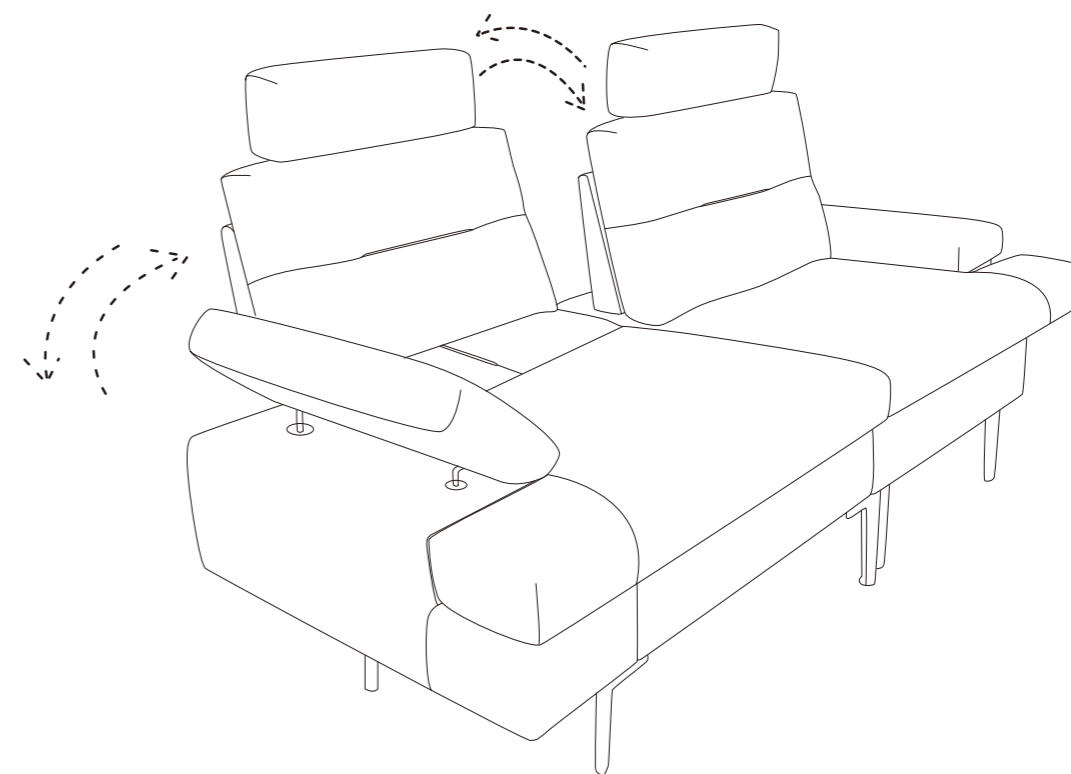

- ① The (O-L)/(O-R) components have three angle adjustments ranging from 135 to 180 degrees.
 - ② To reset to the flat position, first adjust to the maximum angle, then push inward until fully seated.
2. The (M) backrest can be pushed backward to increase the seating depth according to your needs.

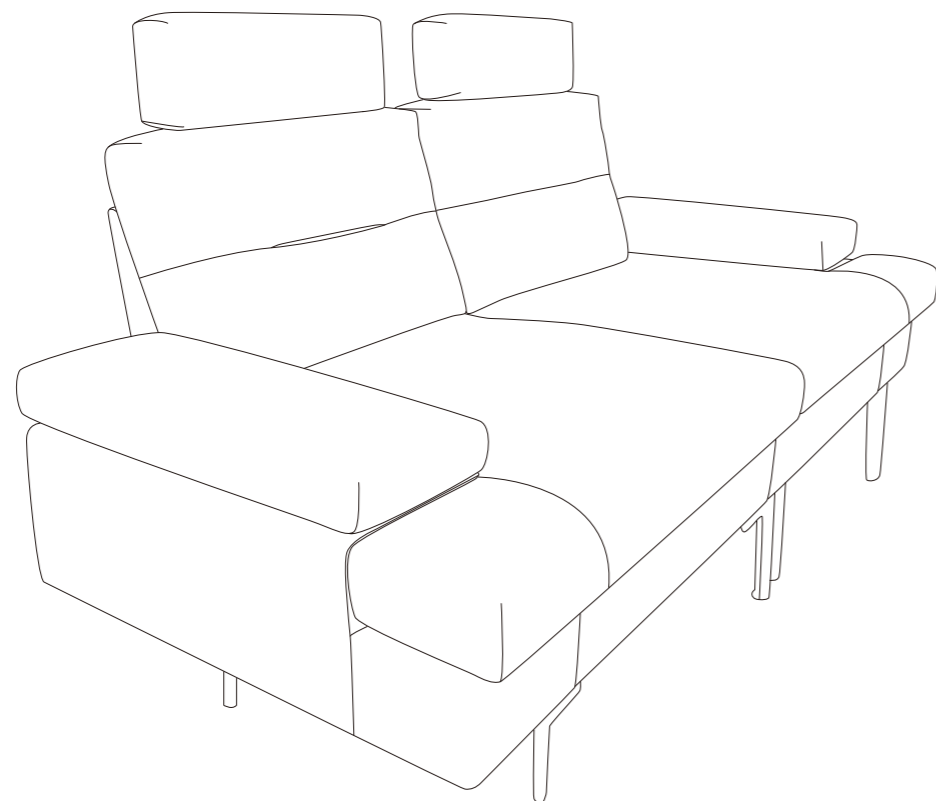

1. Avoid direct sunlight, preferably placed in a place that can avoid sunlight, or use translucent tulle curtains to block the sun.
2. Vacuum at least once a week, paying particular attention to removing dust accumulation between fabric structures.
3. Sofa cushions are turned over once a week to evenly distribute wear.
4. If stained, use a clean cloth dipped in water to wipe. In order to avoid leaving marks, it is best to wipe from the periphery of the stain. Velvet furniture should not be dipped in water and should use a dry cleaning agent.
5. All cloth covers and bushings should be dry-cleaned, not washed, not bleached.
6. If you find loose thread, do not tear it with your hand; it is best to cut the thread neatly with scissors.