

ASSEMBLY INSTRUCTION

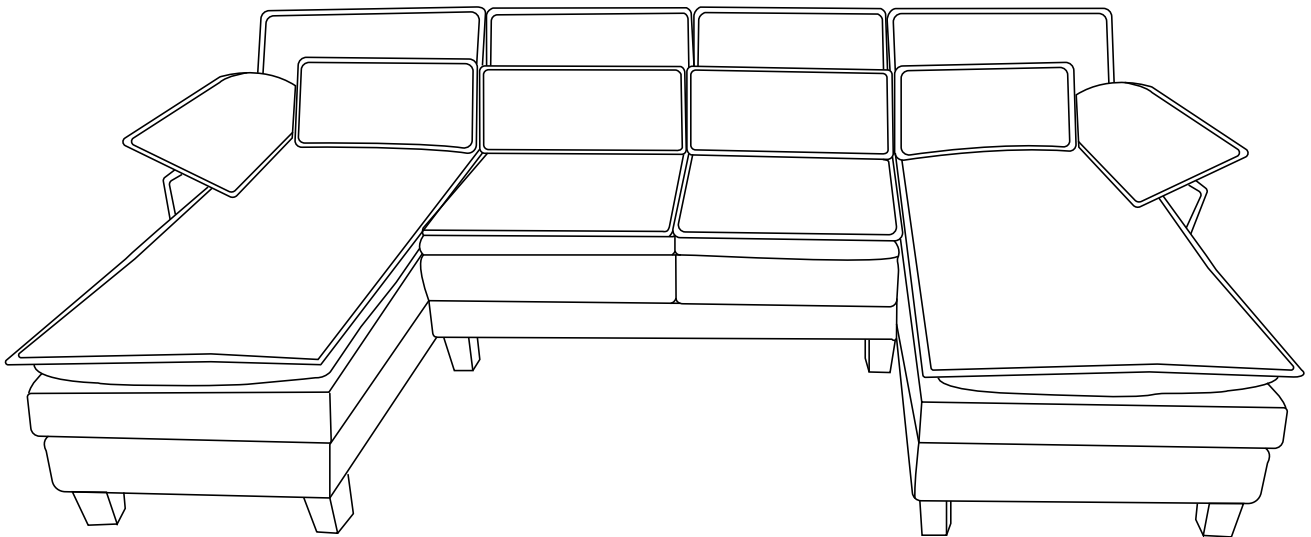

Friendly Reminder:

- 1.This sofa is packed in 3 boxes. Please assemble it after all boxes are received.
- 2.As the cushions are all vacuum compressed,there will be some wrinkles. Please give your cushions up to 24 hours to reach its original size and the wrinkles will basically disappear.
- 3.Please read this manual carefully before any operation and keep it properly for future use.

Module A

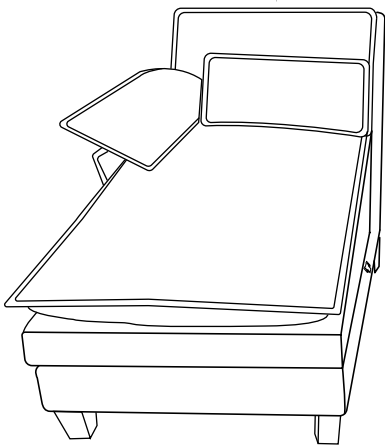

(Box A)

Module B

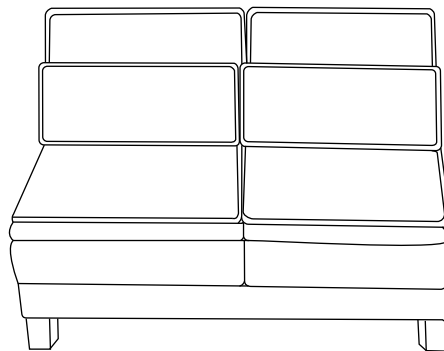

(Box B)

Module C

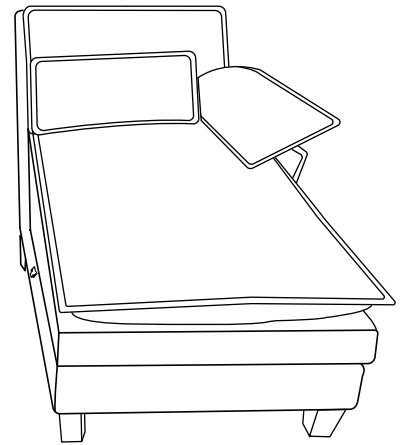

(Box C)

Module A installation steps refer to P2-5

Module B installation steps refer to P6-8

Module C installation steps refer to P9-12

Components List-Module A

In addition to the normal required quantity,

Ⓐ Ⓑ has 1 spare part

Tips: There are three boxes of sofas in total. Vacuum compression requires waiting for 24 hours for rebound.

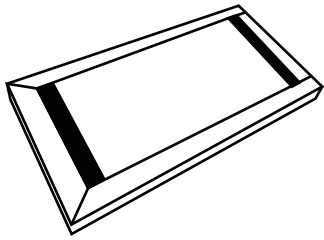

Seat frame ① * 1

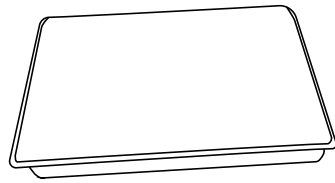

Cushion ② * 1

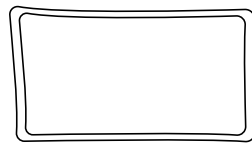

Pillow ③ * 1

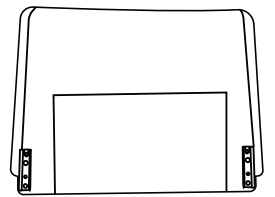

Backrest ④ * 1

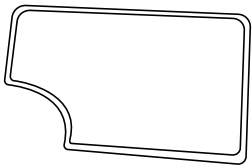

Headrest ⑤ * 1

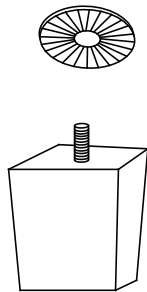

Feet/Feet Pad ⑥ * 4

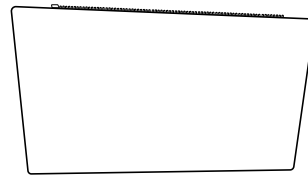

Armrest ⑦ * 1

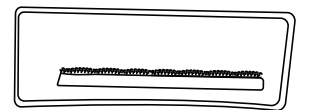

Armrest soft bag ⑧ * 1



M6*65mm Ⓐ * 2

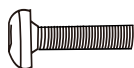

M6*35mm Ⓑ * 2

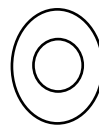

Spacer Ⓒ * 4

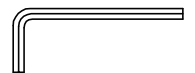

Spanner Ⓓ * 1

Assembly Instruction -Module A

Step 1

Please install the feet.

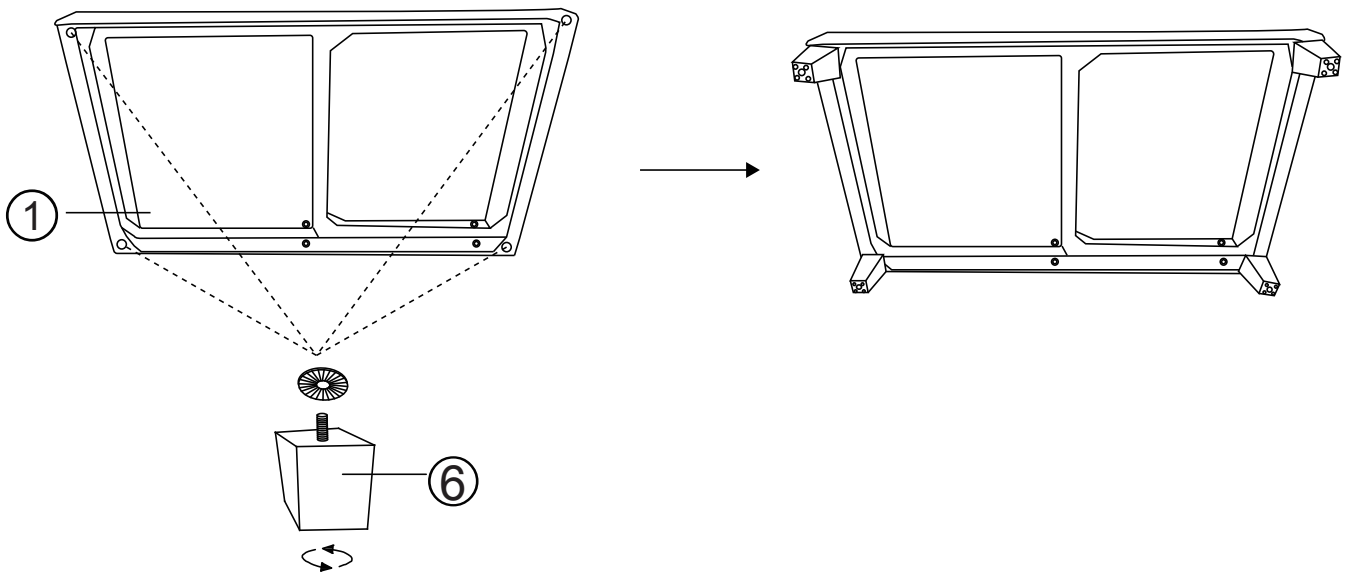

Step 2

Please install the screws on the back frame and armrest first

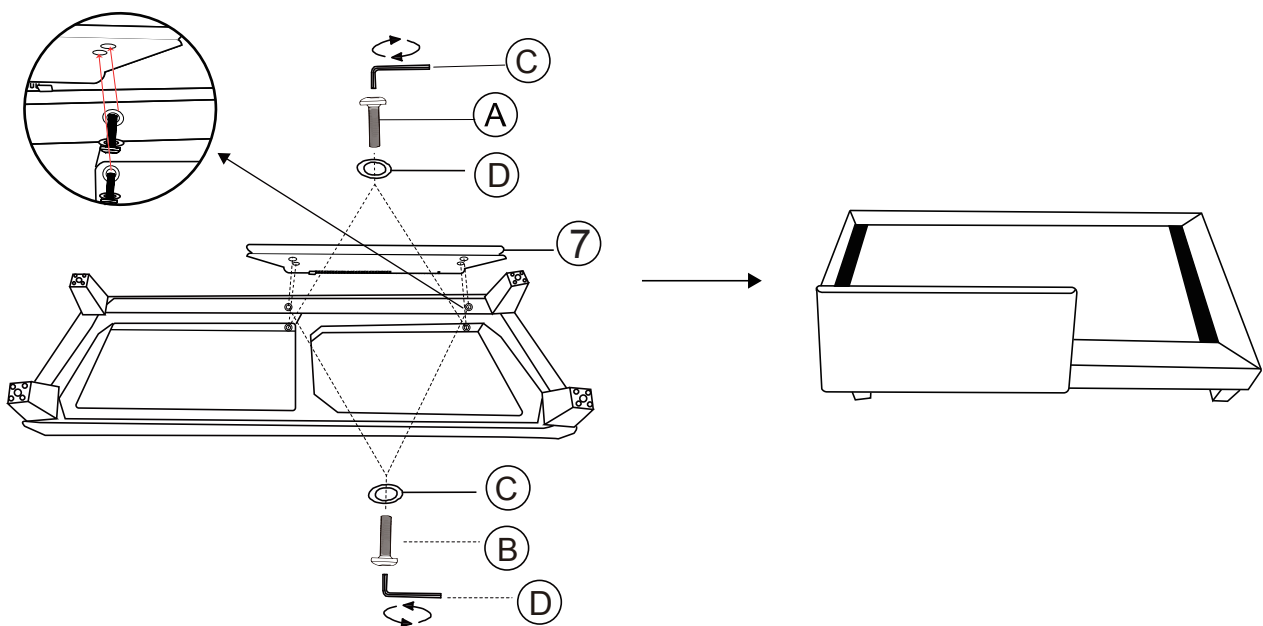

Step 3

Please install the backrest and install the armrest soft bag.

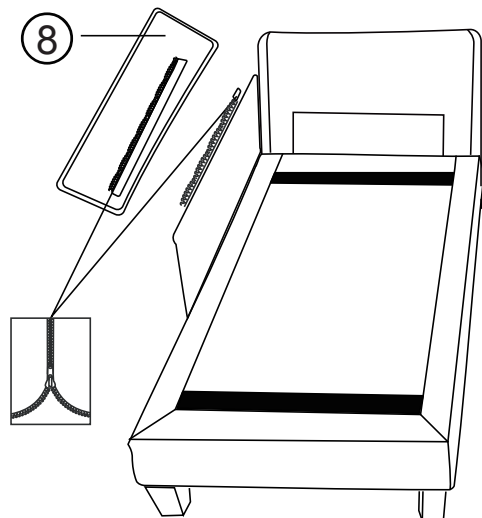
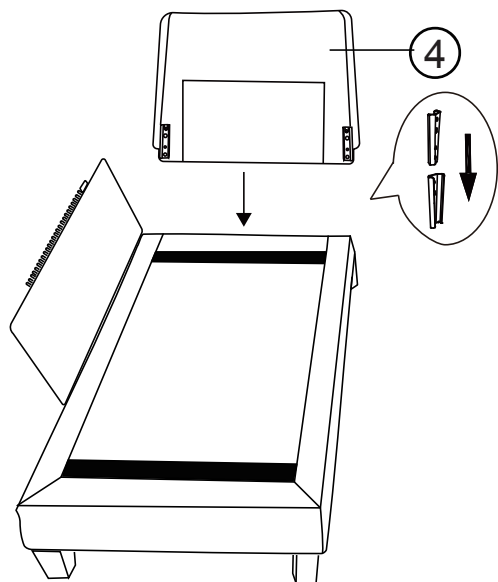

Step 4

Please put the cushion in and turn over the armrest soft bag.

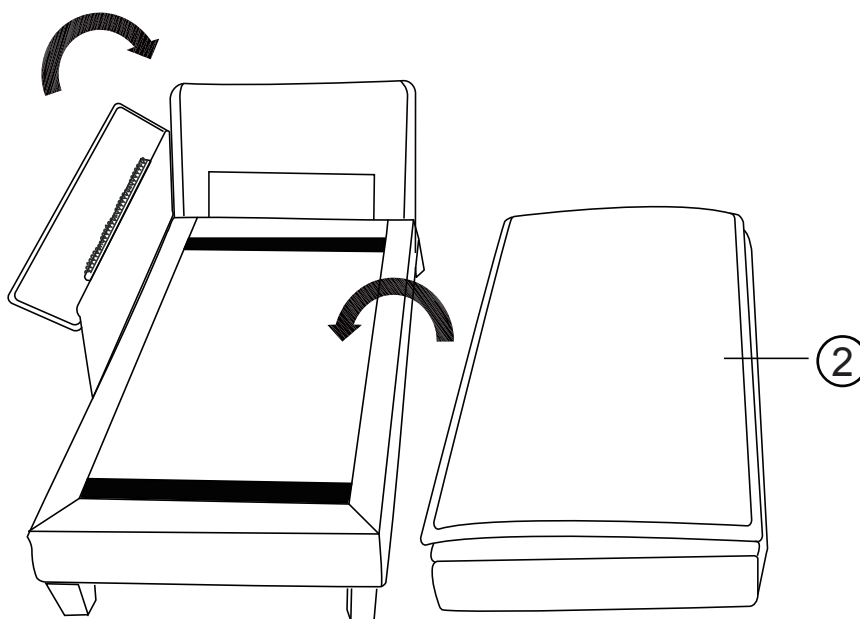

Step 5

Please place the seat cushion, backrest, and pillow properly

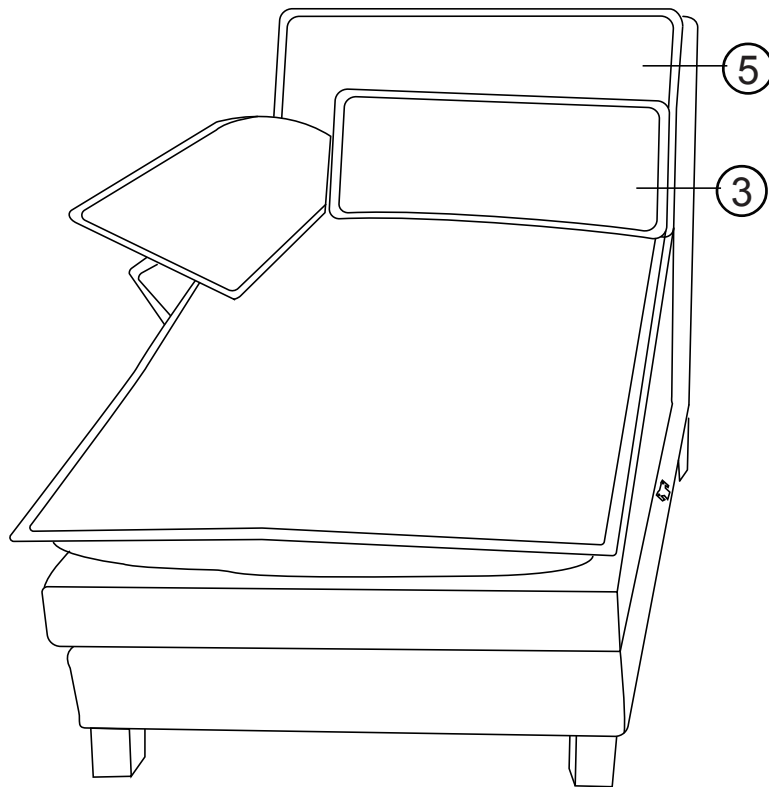

Components List-Module B

Tips : There are three boxes of sofas in total. Vacuum compression requires waiting for 24 hours for rebound.

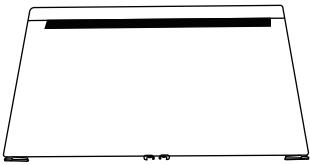

Seat frame ① * 1

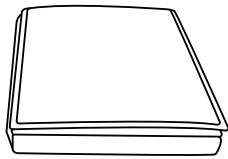

Cushion ② * 2

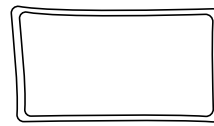

Pillow ③ * 2

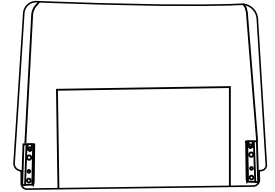

Backrest ④ * 2

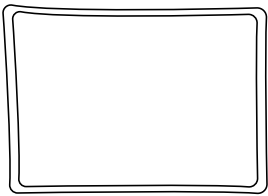

Headrest ⑤ * 2

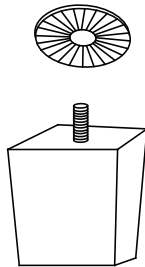

Feet/Feet Pad ⑥ * 4

Step 1

Please install the feet.

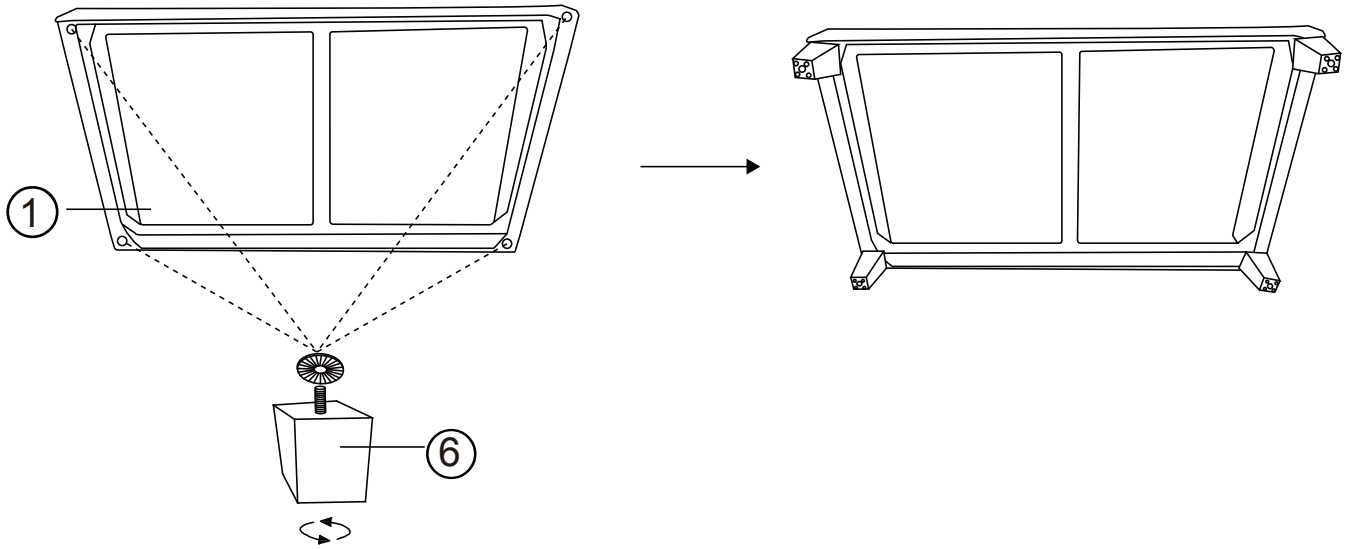

Step 2

Please install the backrest.

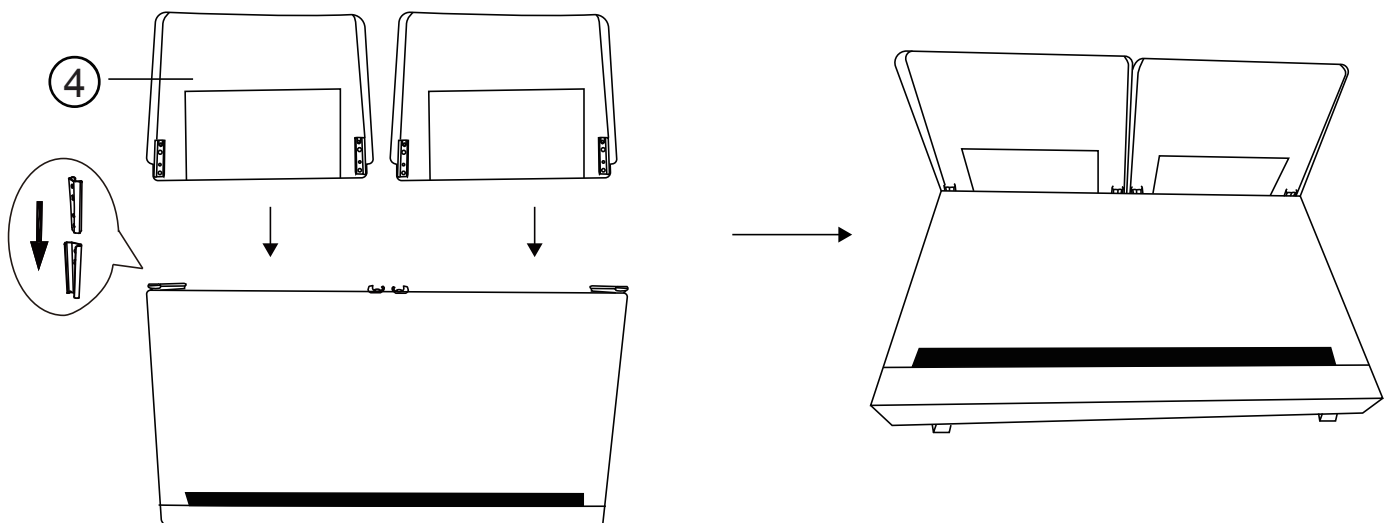

Step 3

Please put the cushion on it.

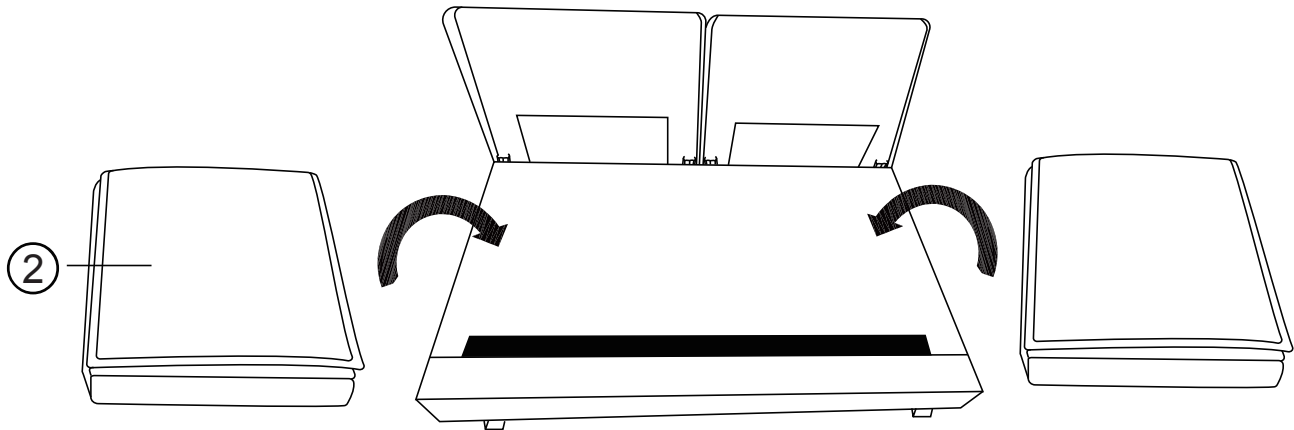

Step 4

Please place the seat cushion, backrest, and pillow properly

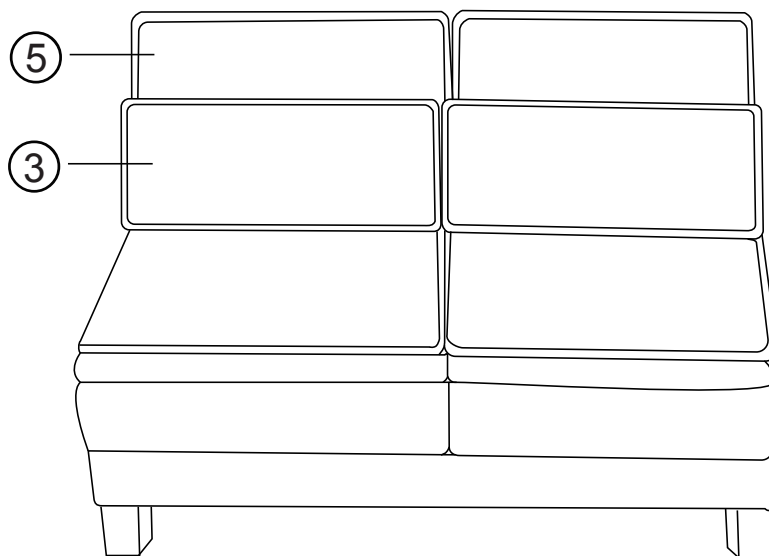

Components List-Module C

In addition to the normal required quantity,

Ⓐ Ⓑ has 1 spare part

Tips: There are three boxes of sofas in total. Vacuum compression requires waiting for 24 hours for rebound.

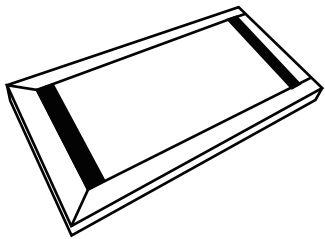

Seat frame ① * 1

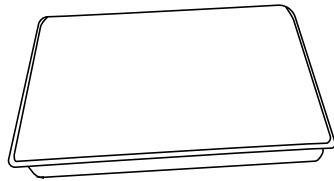

Cushion ② * 1

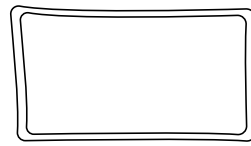

Pillow ③ * 1

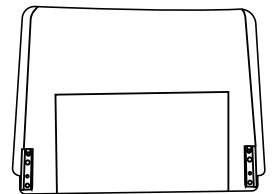

Backrest ④ * 1

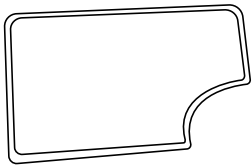

Headrest ⑤ * 1

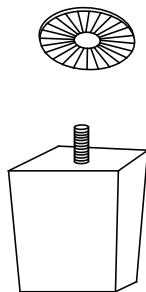

Feet/Feet Pad ⑥ * 4

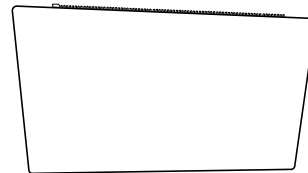

Armrest ⑦ * 1

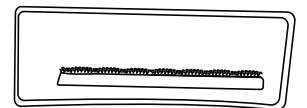

Armrest soft bag ⑧ * 1



M6*65mm Ⓐ * 2

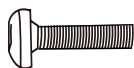

M6*35mm Ⓑ * 2



Spacer Ⓒ * 4



Spanner Ⓓ * 1

Assembly Instruction -Module C

Step 1

Please install the feet.

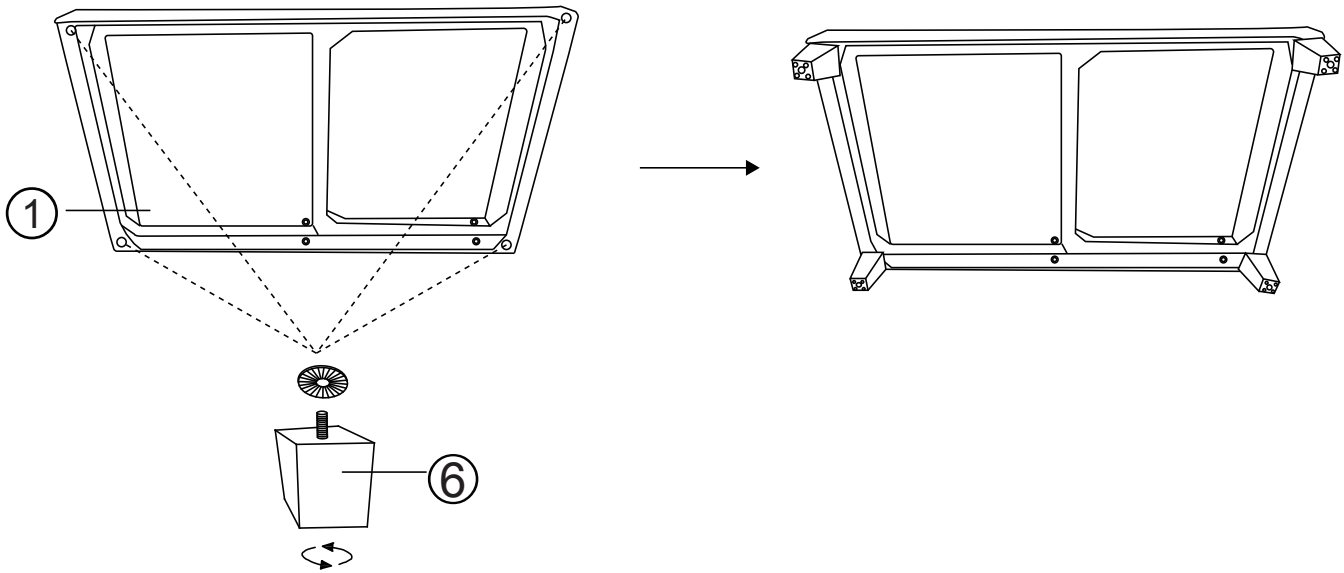

Step 2

Please install the screws on the back frame and armrest first

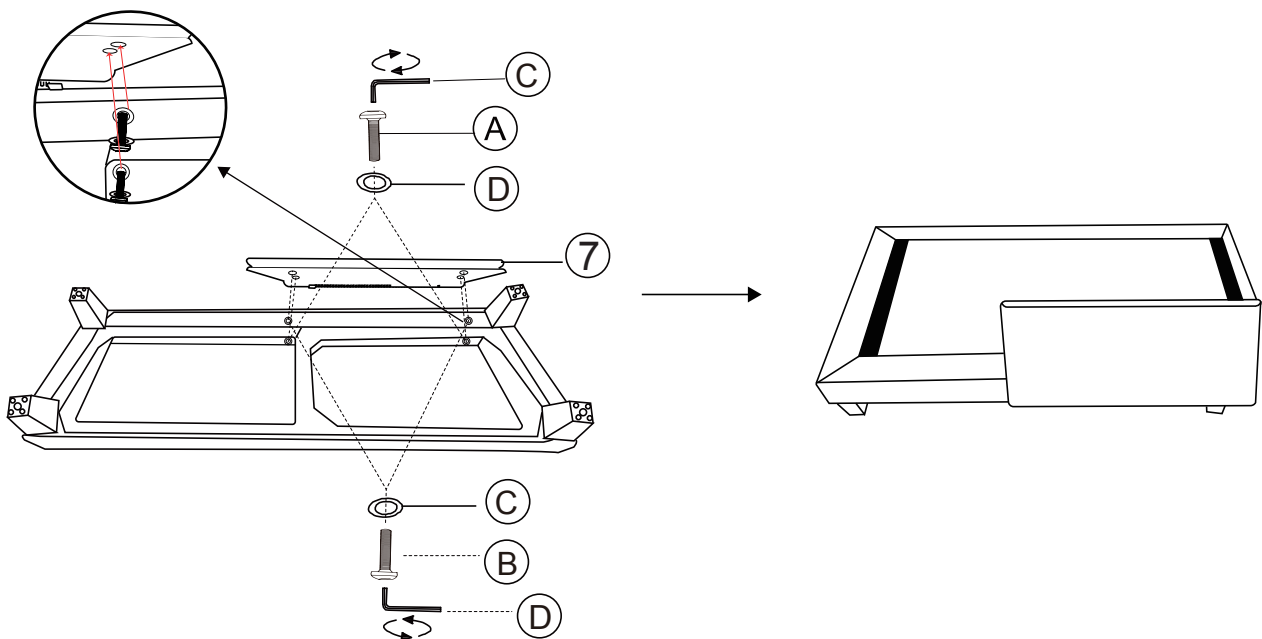

Step 3

Please install the backrest and install the armrest soft bag.

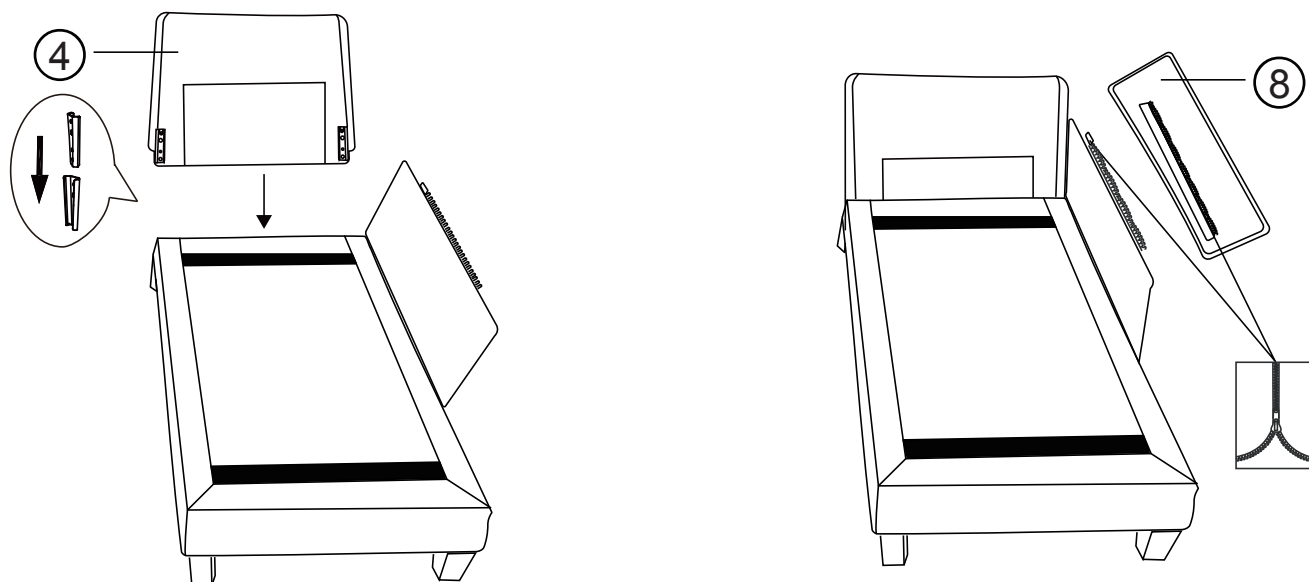

Step 4

Please put the cushion in and turn over the armrest soft bag.

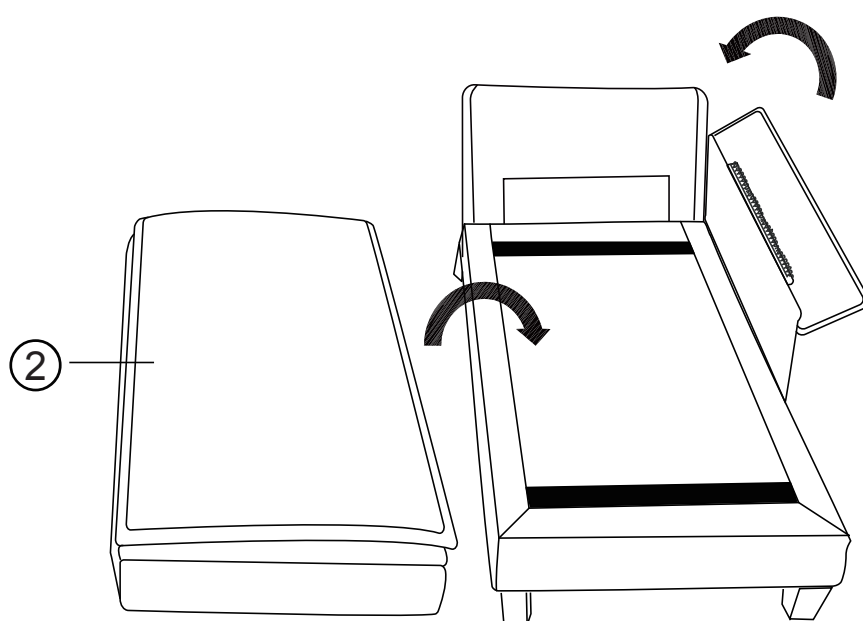

Step 5

Please place the seat cushion, backrest, and pillow properly

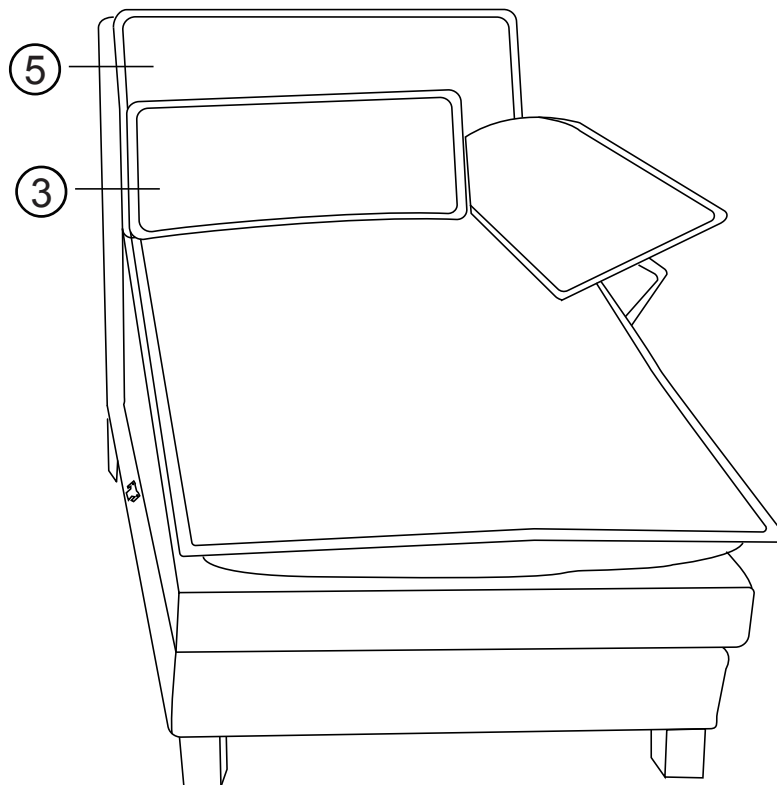

Assembly Instruction-U Shaped

Fix the assembled sofa together A、 B with C.

