

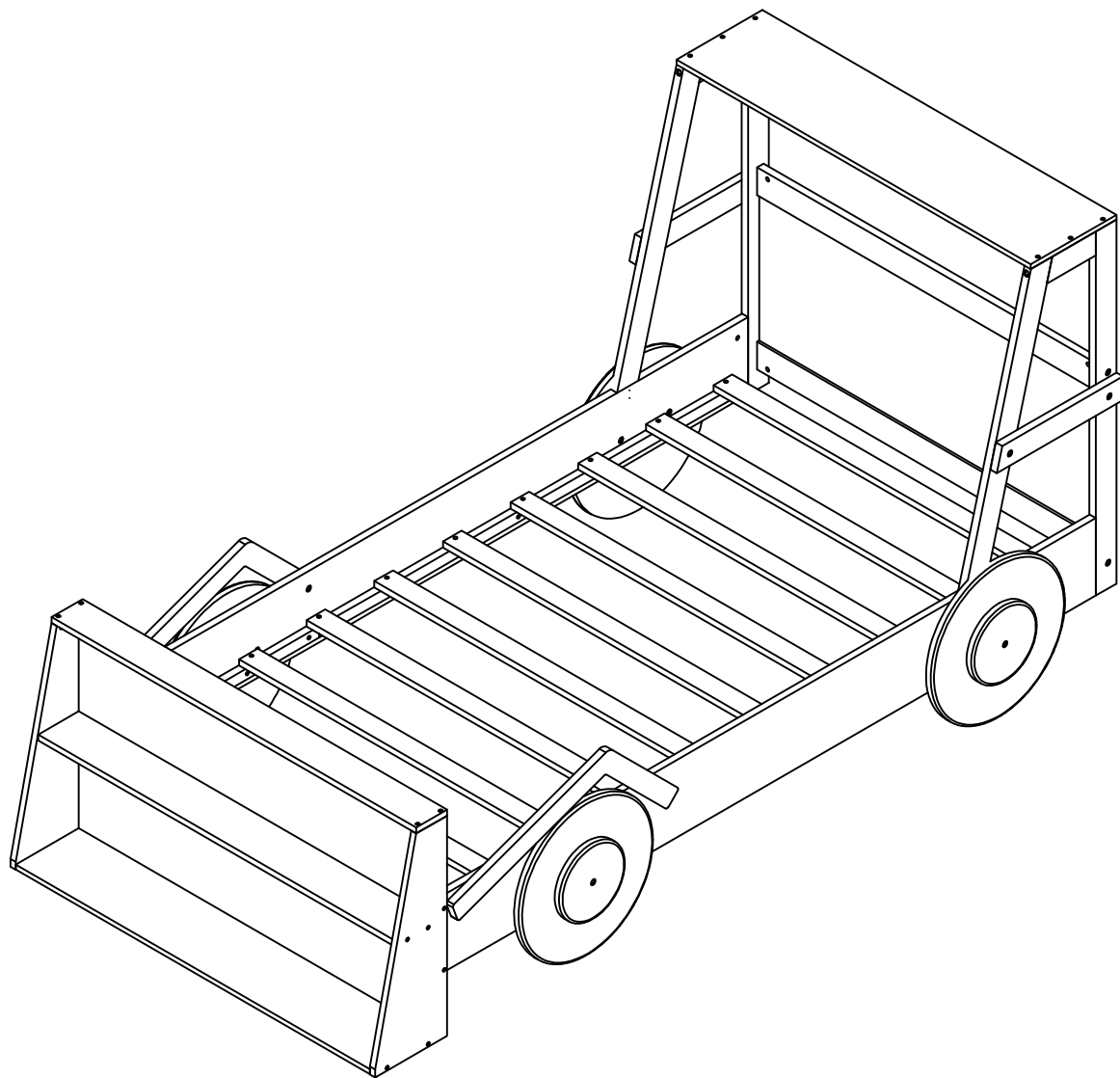

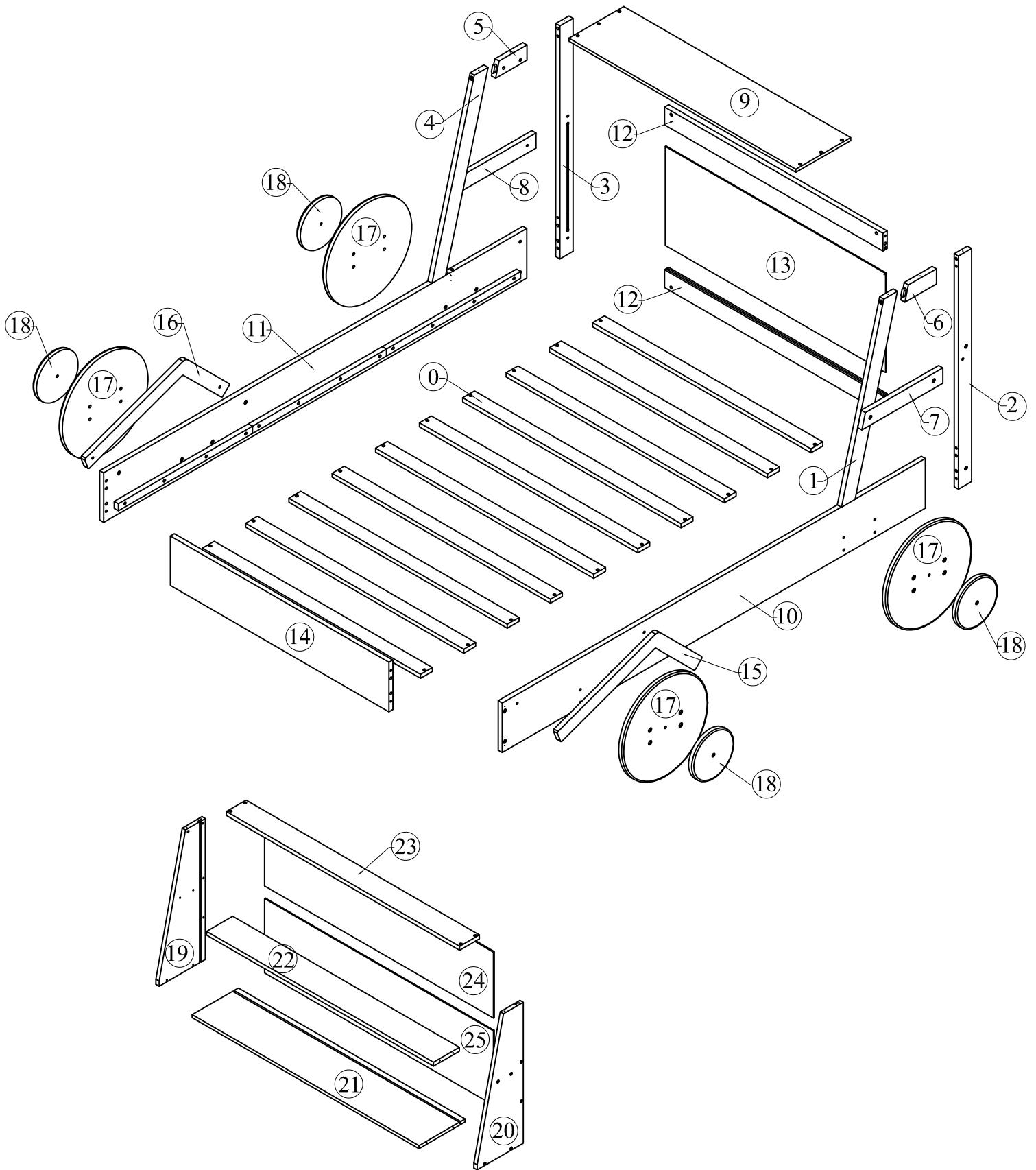



ASSEMBLY INSTRUCTION





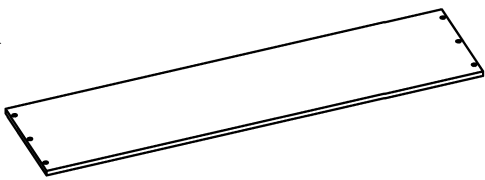
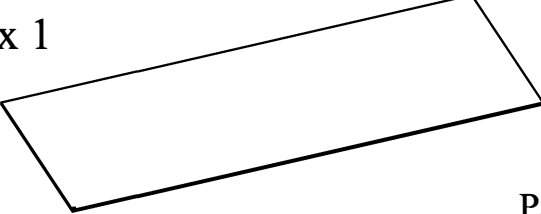

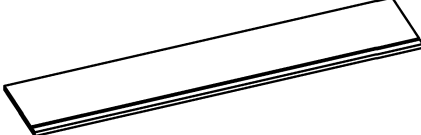
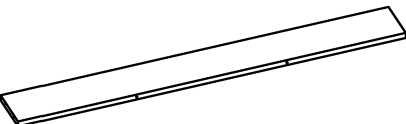

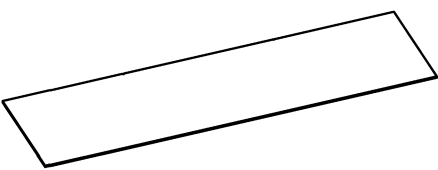
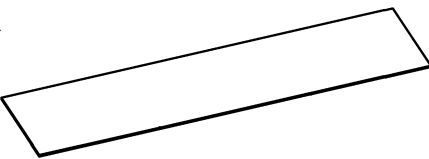
ASSEMBLY INSTRUCTION



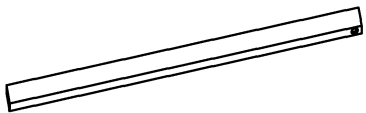
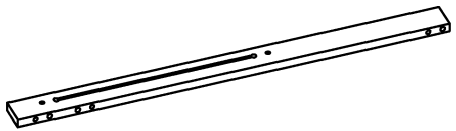
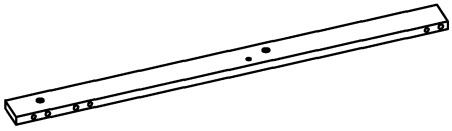
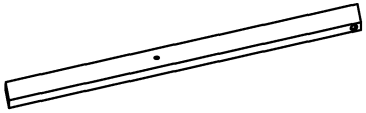



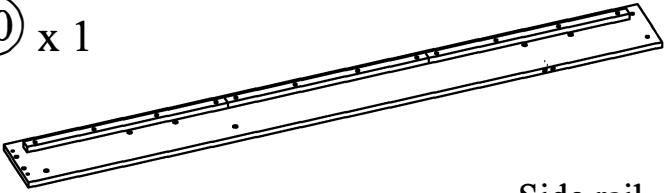
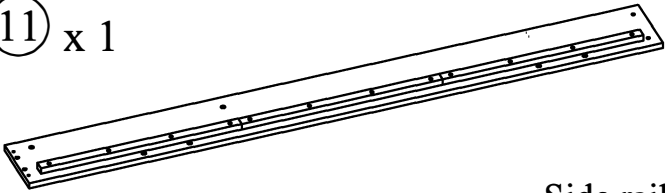
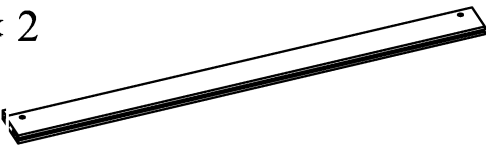
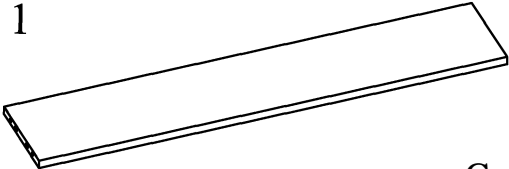
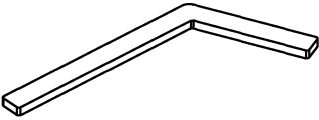

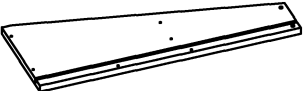
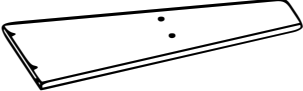



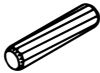

Part List & Hardware List (Box 1)

<p>① x 10</p>  <p>Slats</p>	<p>⑨ x 1</p>  <p>Panel</p>
<p>⑬ x 1</p>  <p>Panel</p>	<p>⑰ x 4</p>  <p>Wooden wheel</p>
<p>⑱ x 4</p>  <p>Wooden circular panel</p>	<p>⑳ x 1</p>  <p>Shelf board</p>
<p>㉒ x 1</p>  <p>Shelf board</p>	<p>㉓ x 1</p>  <p>Top panel</p>
<p>㉔ x 1</p>  <p>Panel</p>	<p>㉕ x 1</p>  <p>Panel</p>

Part List (Box 2)

<p>① x 1</p>  <p style="text-align: center;">Diagonal brace</p>	<p>② x 1</p>  <p style="text-align: center;">Vertical post</p>
<p>③ x 1</p>  <p style="text-align: center;">Vertical post</p>	<p>④ x 1</p>  <p style="text-align: center;">Diagonal brace</p>
<p>⑤ x 1</p>  <p style="text-align: center;">Crossbar</p>	<p>⑥ x 1</p>  <p style="text-align: center;">Crossbar</p>
<p>⑦ x 1</p>  <p style="text-align: center;">Crossbar</p>	<p>⑧ x 1</p>  <p style="text-align: center;">Crossbar</p>
<p>⑩ x 1</p>  <p style="text-align: center;">Side rail</p>	<p>⑪ x 1</p>  <p style="text-align: center;">Side rail</p>
<p>⑫ x 2</p>  <p style="text-align: center;">Crossbar</p>	<p>⑭ x 1</p>  <p style="text-align: center;">Crossbar</p>
<p>⑮ x 1</p>  <p style="text-align: center;">Decorative strip</p>	<p>⑯ x 1</p>  <p style="text-align: center;">Decorative strip</p>
<p>⑰ x 1</p>  <p style="text-align: center;">Side panel</p>	<p>⑳ x 1</p>  <p style="text-align: center;">Side panel</p>

Hardware List (Box 1)

No.	OUTLOOK	DESC	QTY
(A)		Dowel Ø10*40mm	18
(B)		Bolts 1/4"*25mm	28
(C)		Bolts 1/4"*60mm	08
(D)		Bolts 1/4"*100mm	08
(E)		Cross dowel 1/4"*13mm	16
(F)		Hex bolts 1/4"*15mm	16
(G)		Round Head Screw #7*15mm	08
(H)		Round Head Screw #8*25mm	02
(I)		Screws #8*25mm	10
(J)		Screws #8*30mm	20
(K)		Screws #8*35mm	12
(L)		Metal bracket	02
(M)		Allen key 60*22*4mm	02

ASSEMBLY TOOLS REQUIRED (NOT INCLUDED)



STEP 1

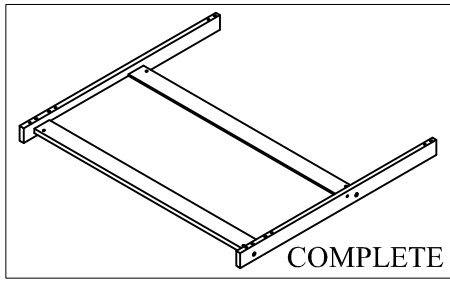

(A)		04
(C)		04
(E)		04

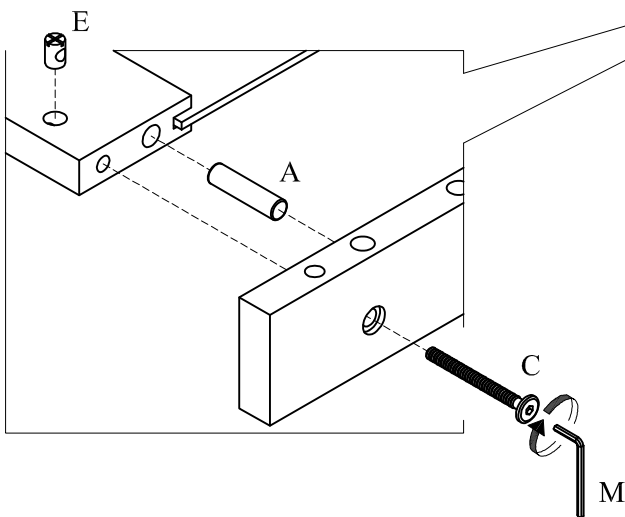
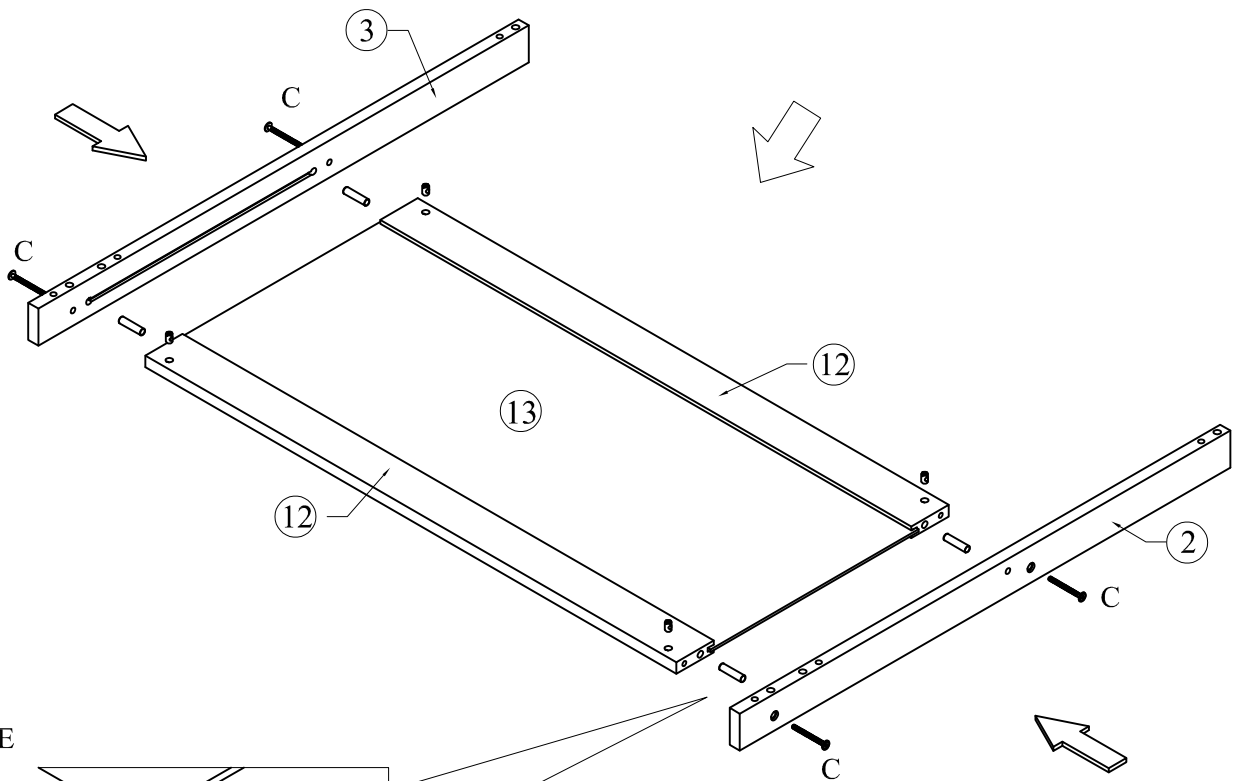
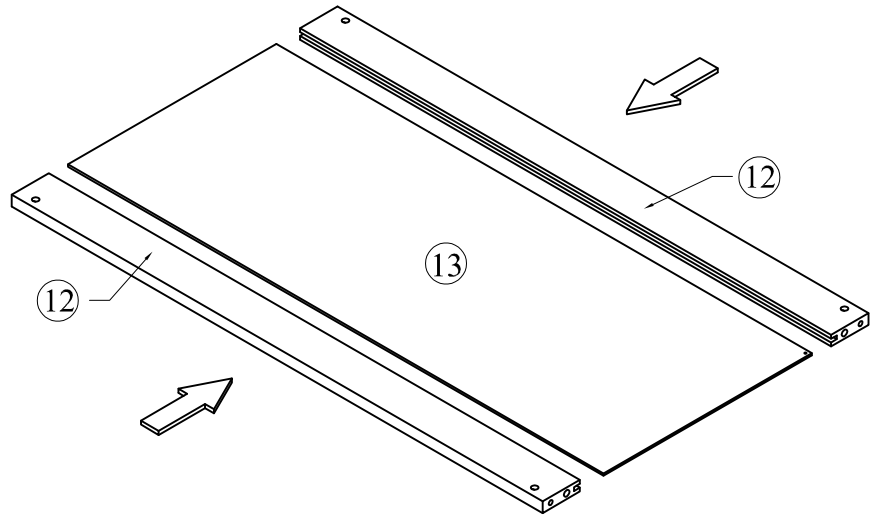

STEP 2

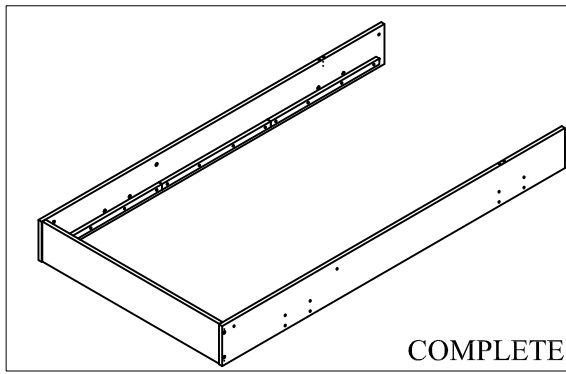

(A)		04
(C)		04
(E)		04

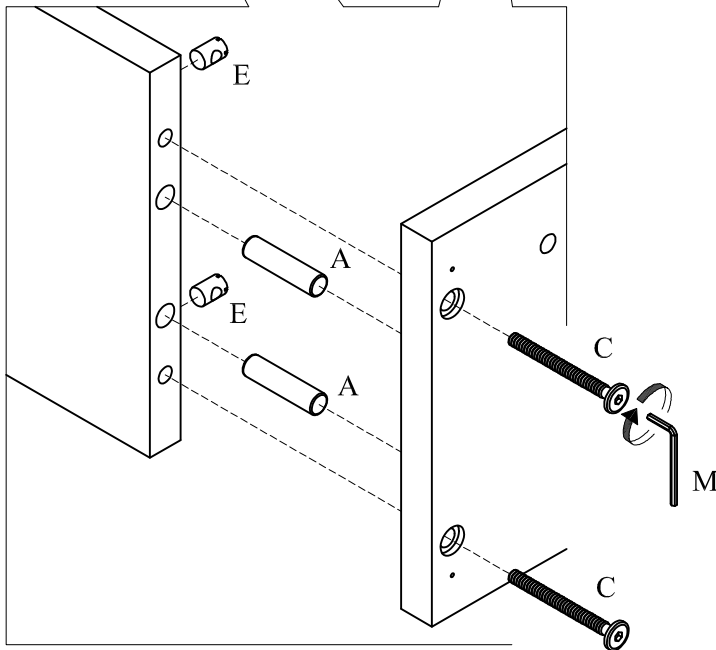
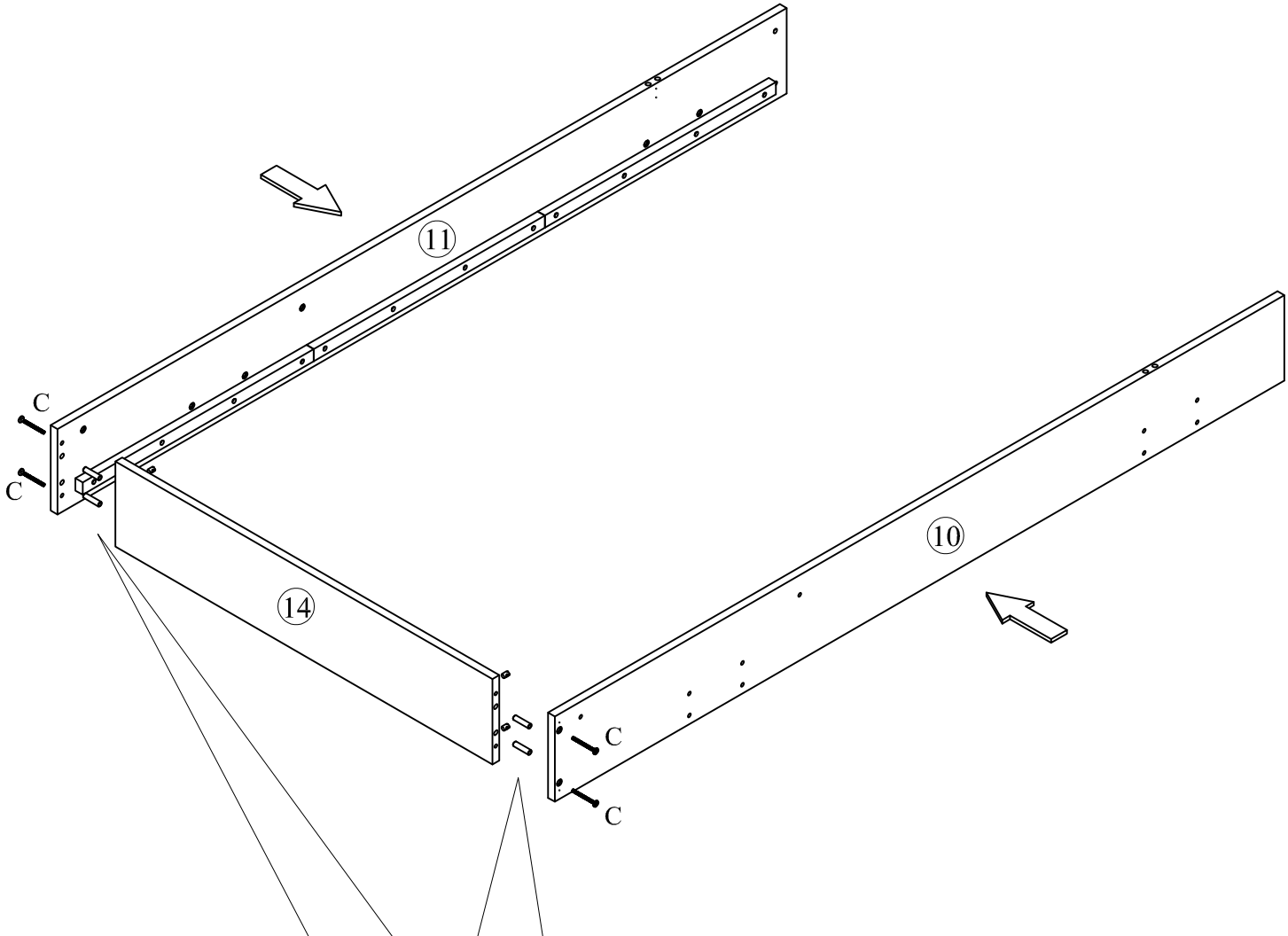

STEP 3

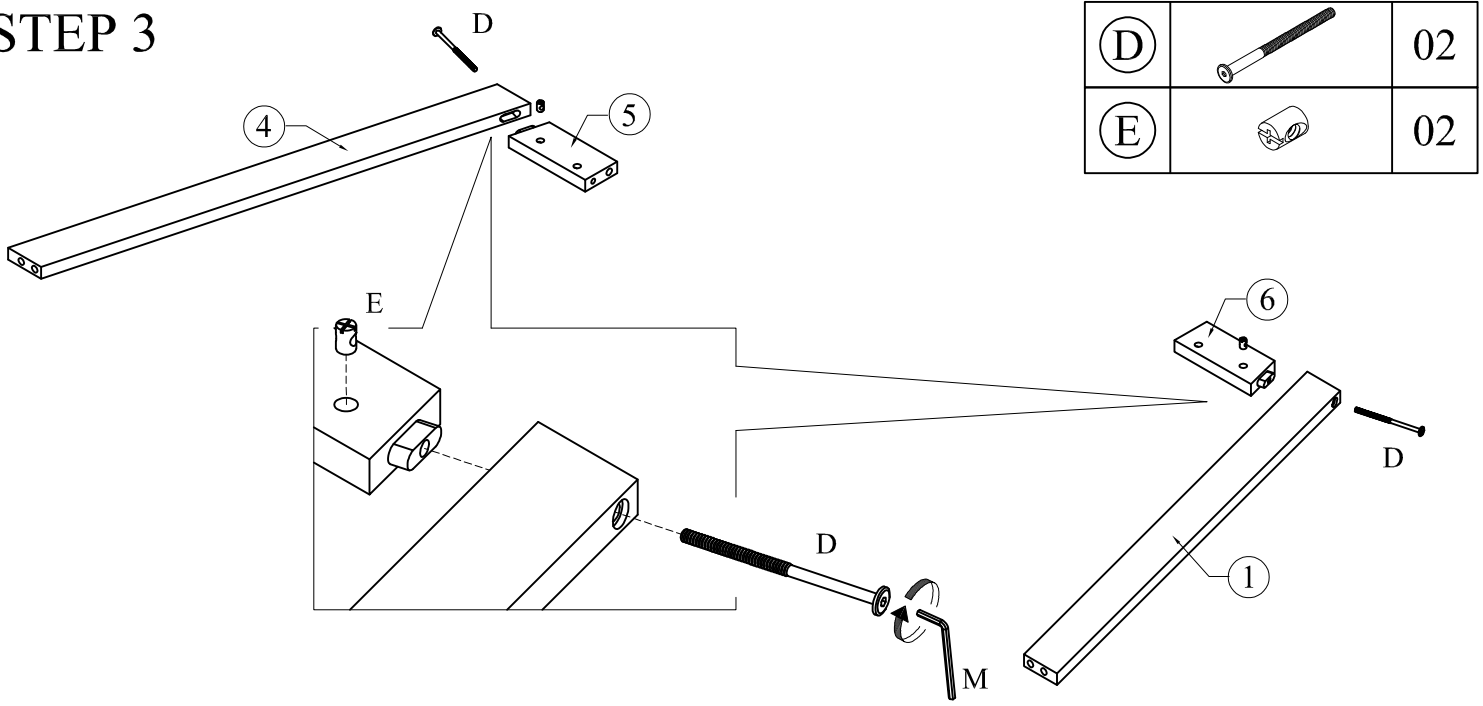

STEP 4

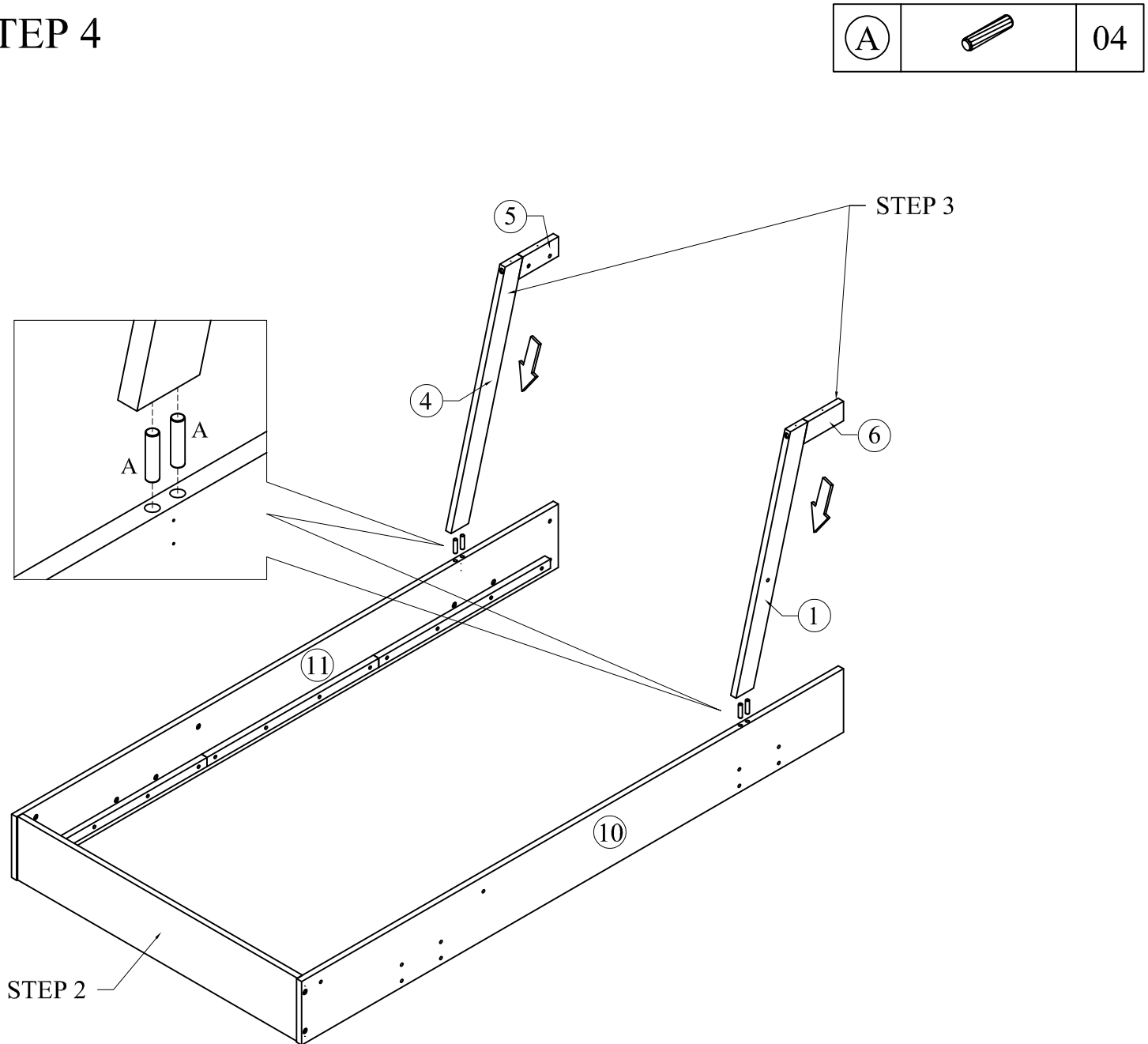

STEP 5

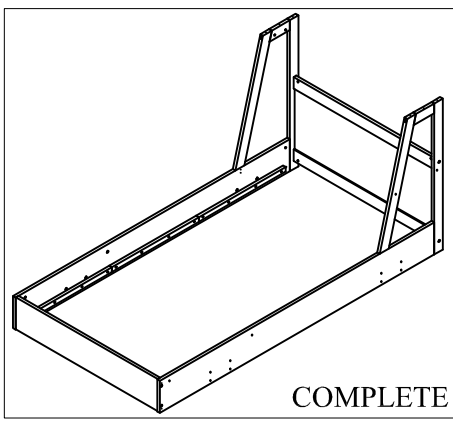

(A)		06
(D)		06
(E)		06

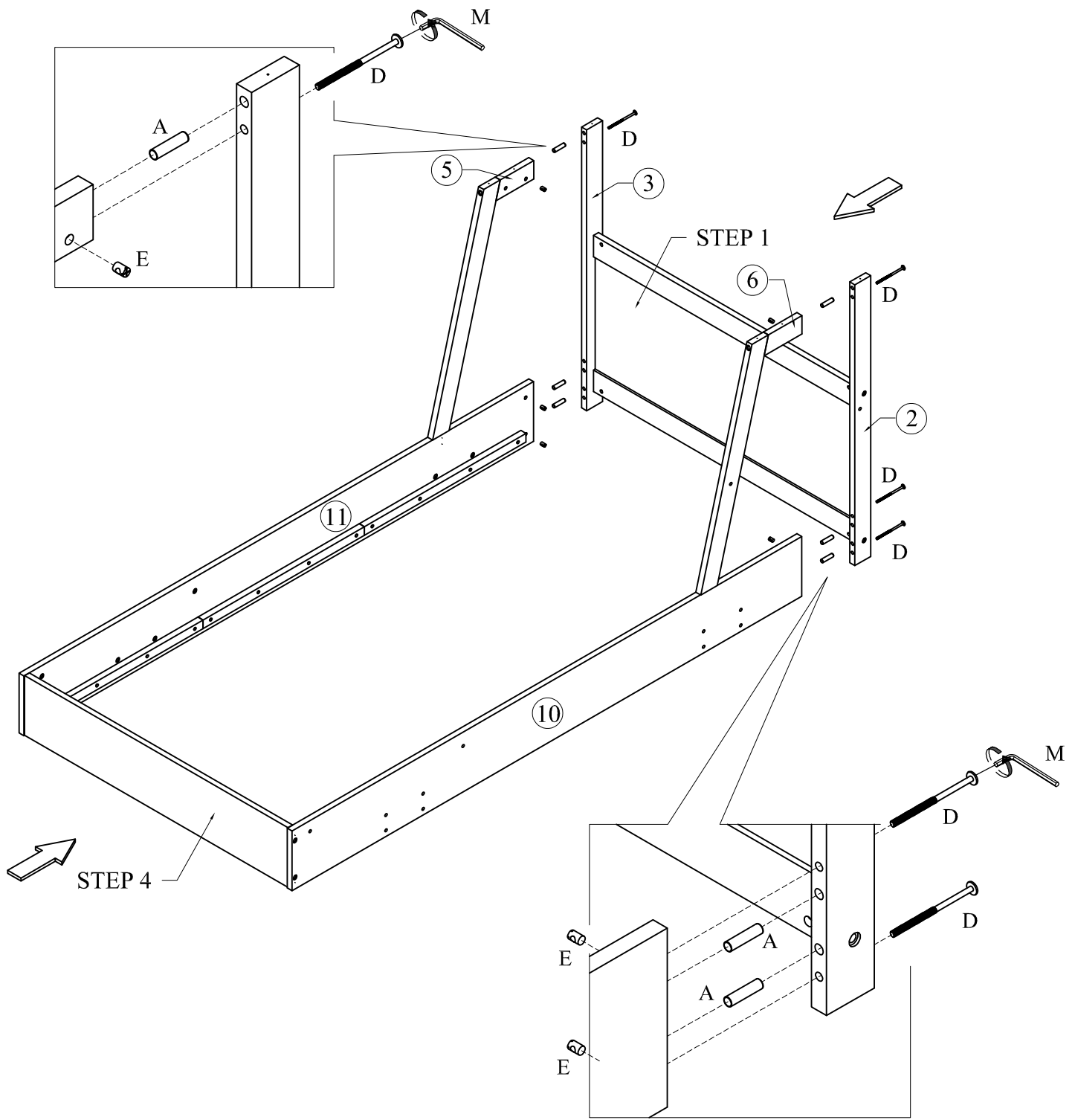

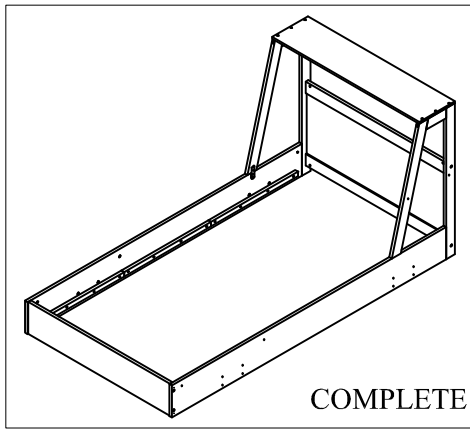

STEP 6

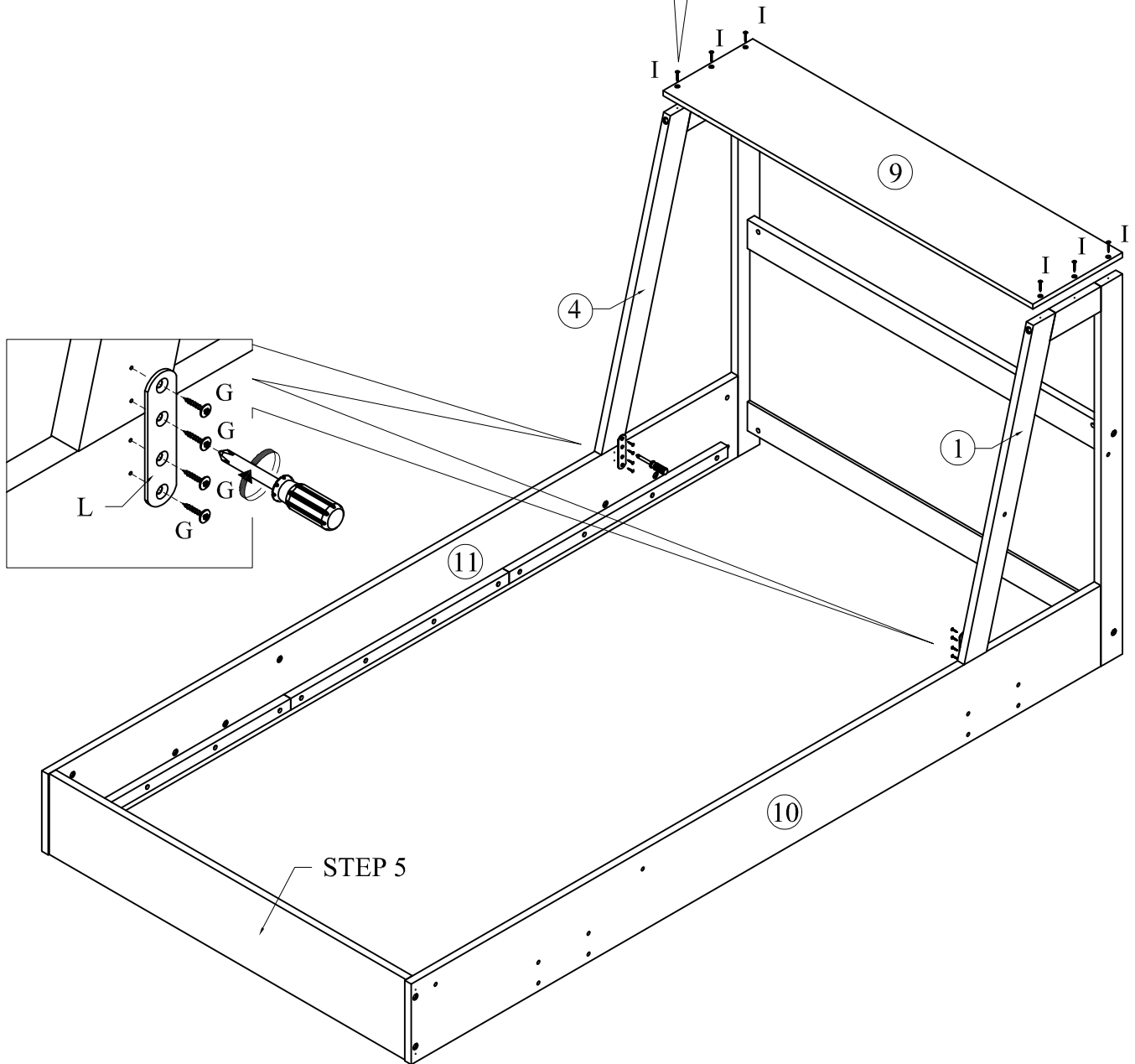
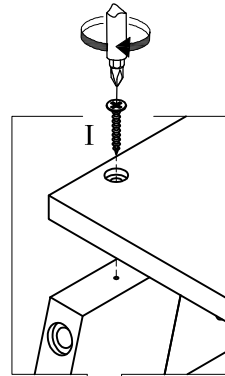

(G)		08
(I)		06
(L)		02



STEP 7-A

(B)		16
(F)		16

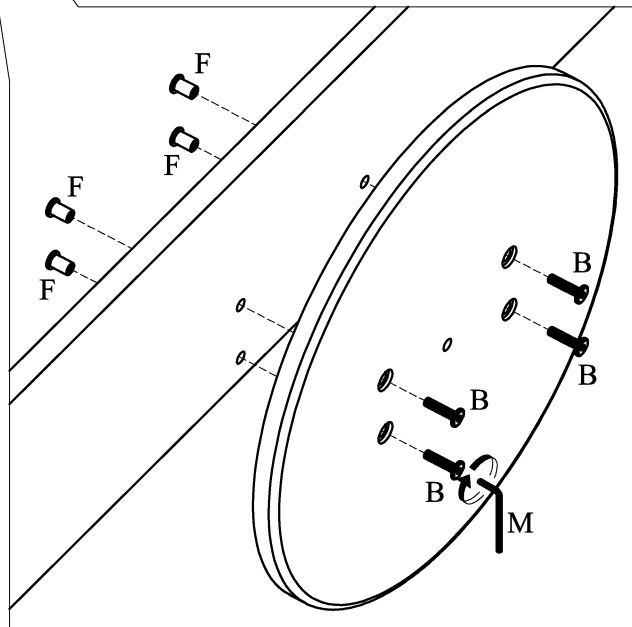
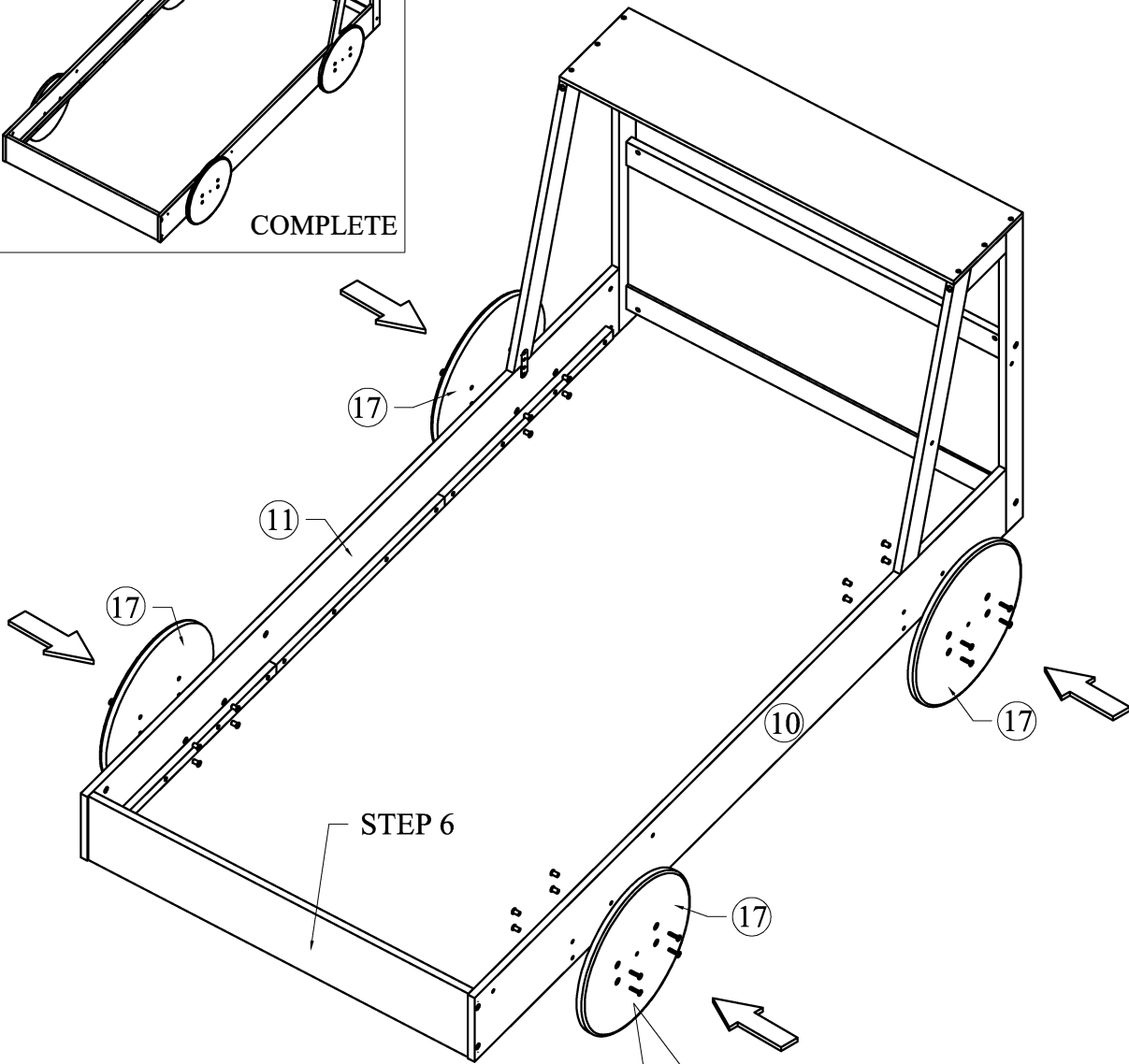
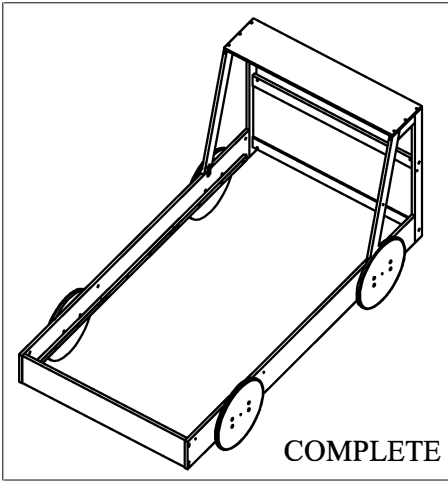

STEP7 - B

(B)



04

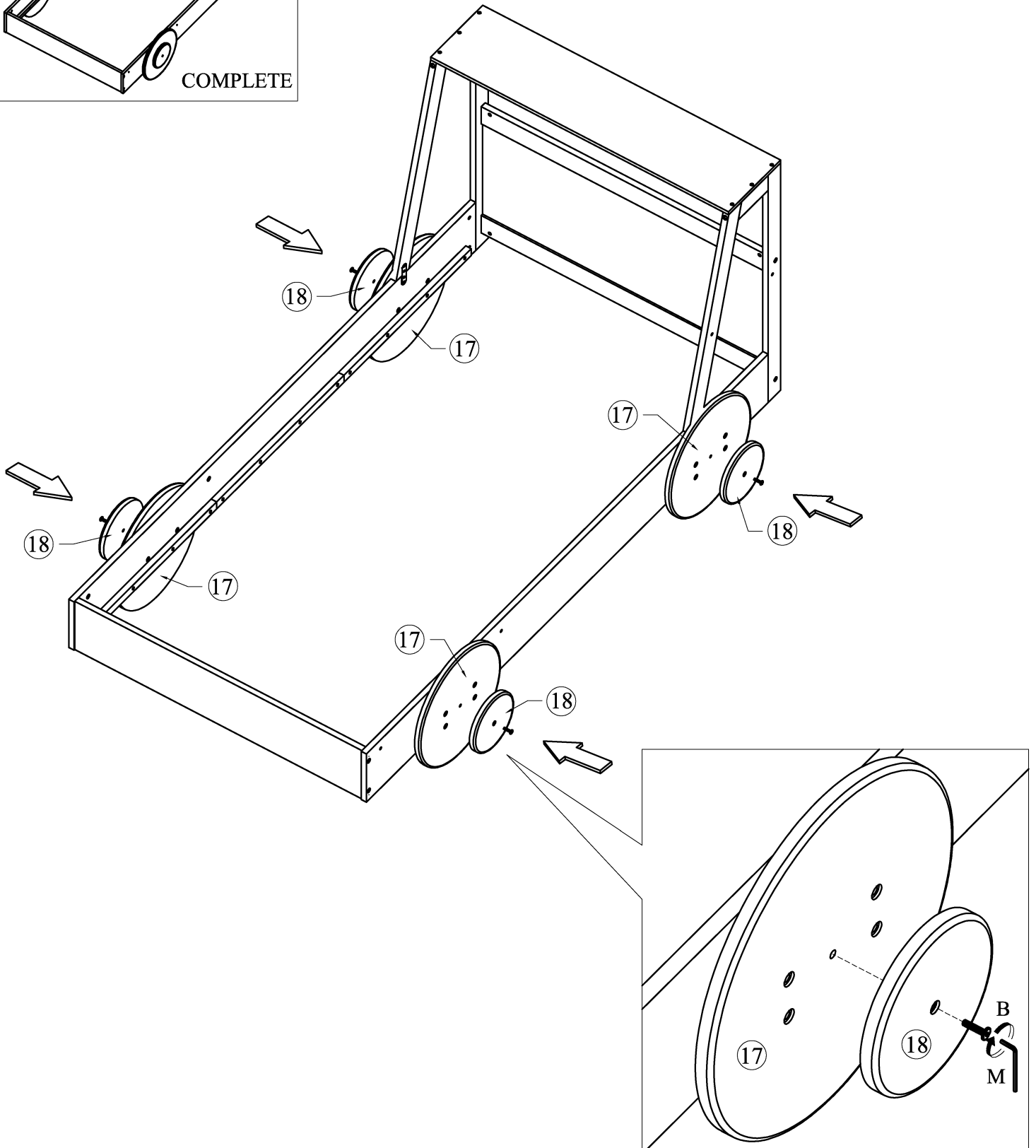
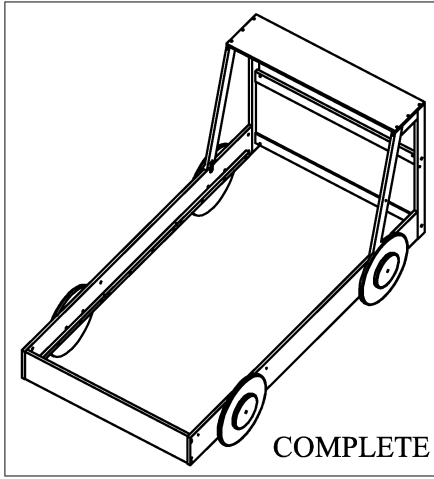

STEP7 - C

B		08
---	---	----

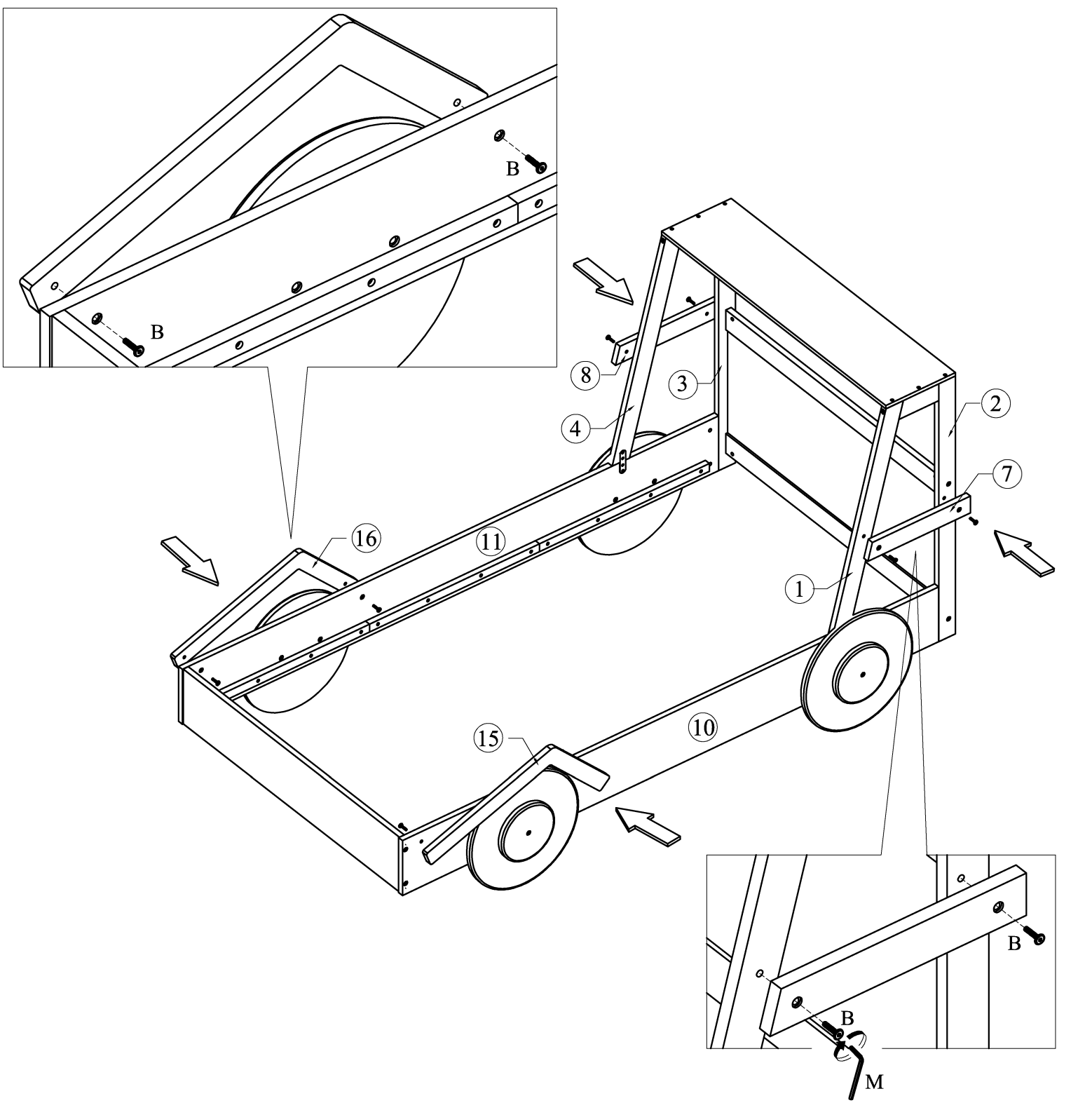
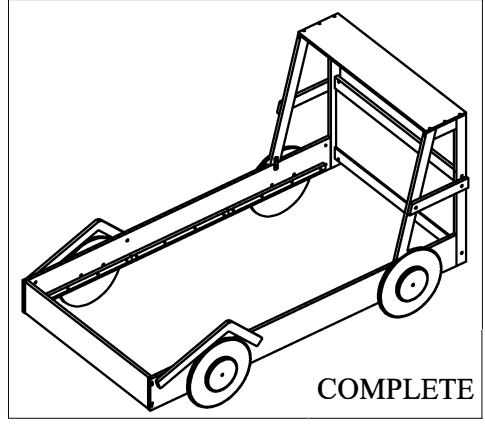

STEP 8

(K)



08

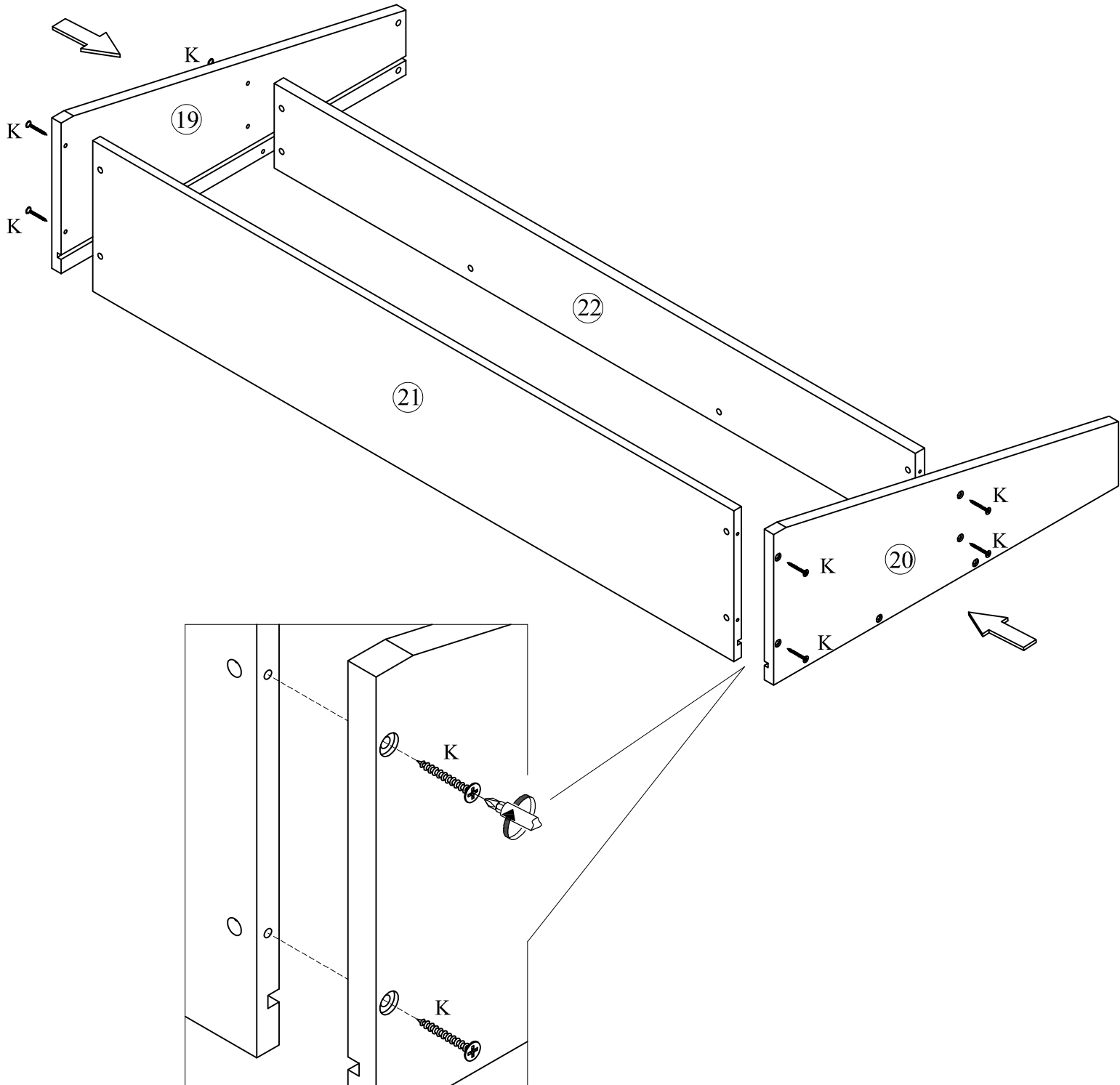
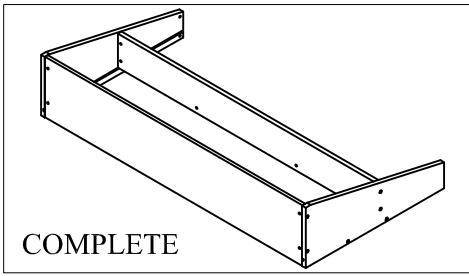

STEP 9

(K)



04

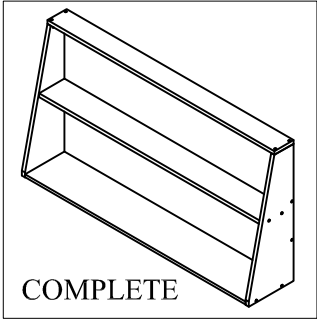

Pre-drilled hole

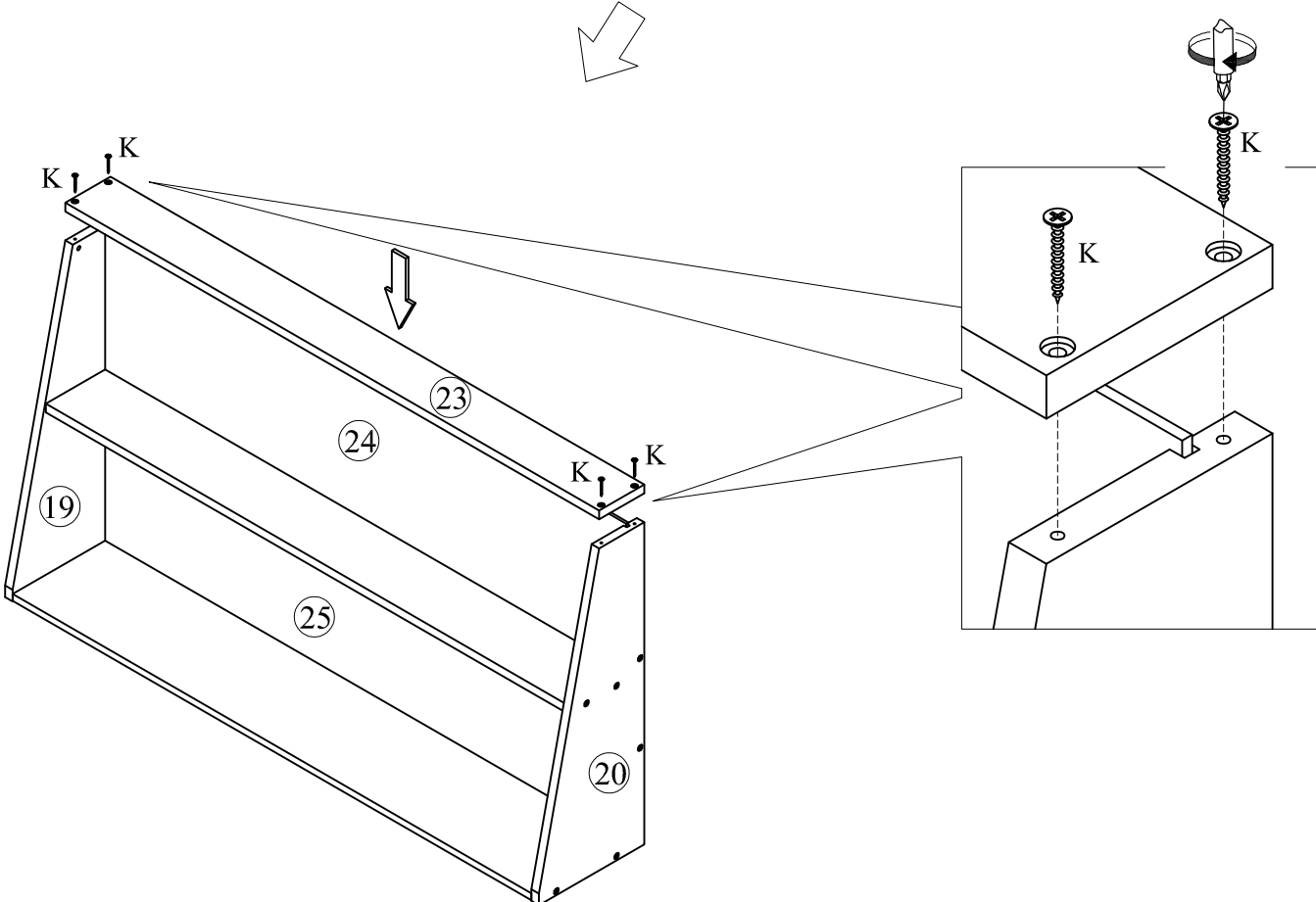
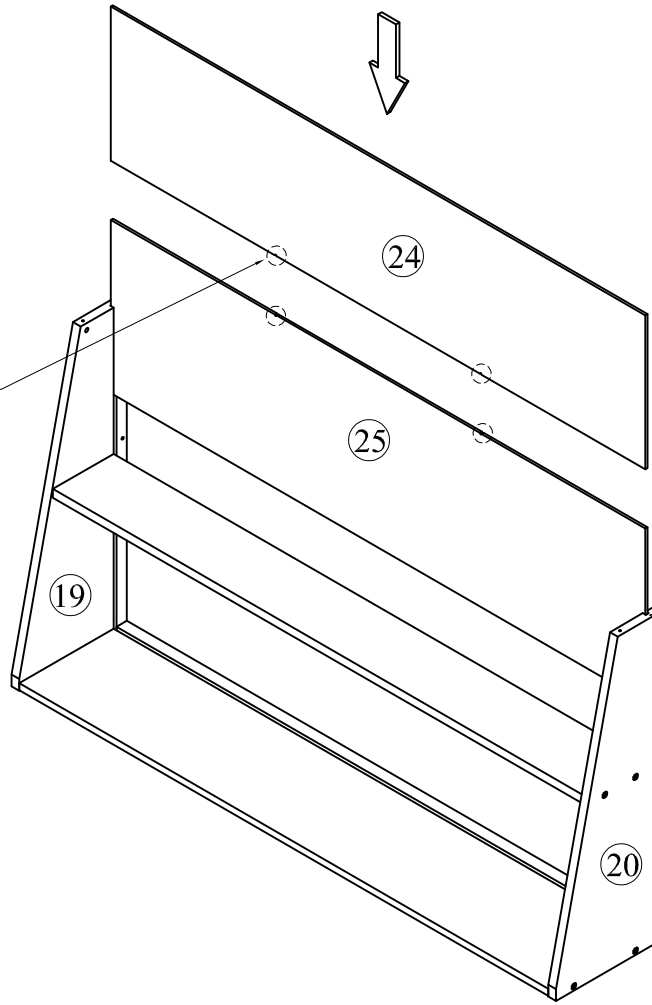

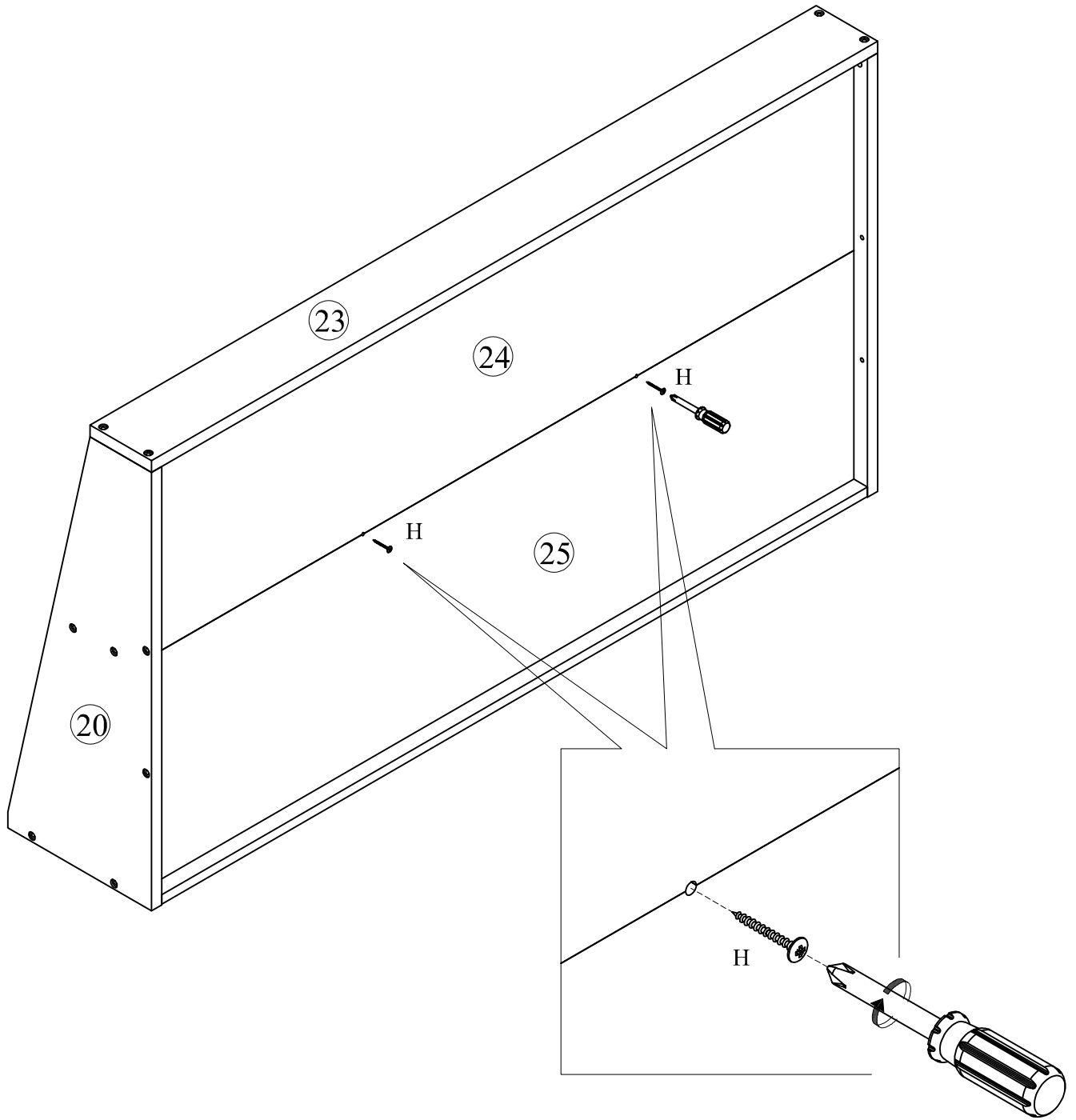

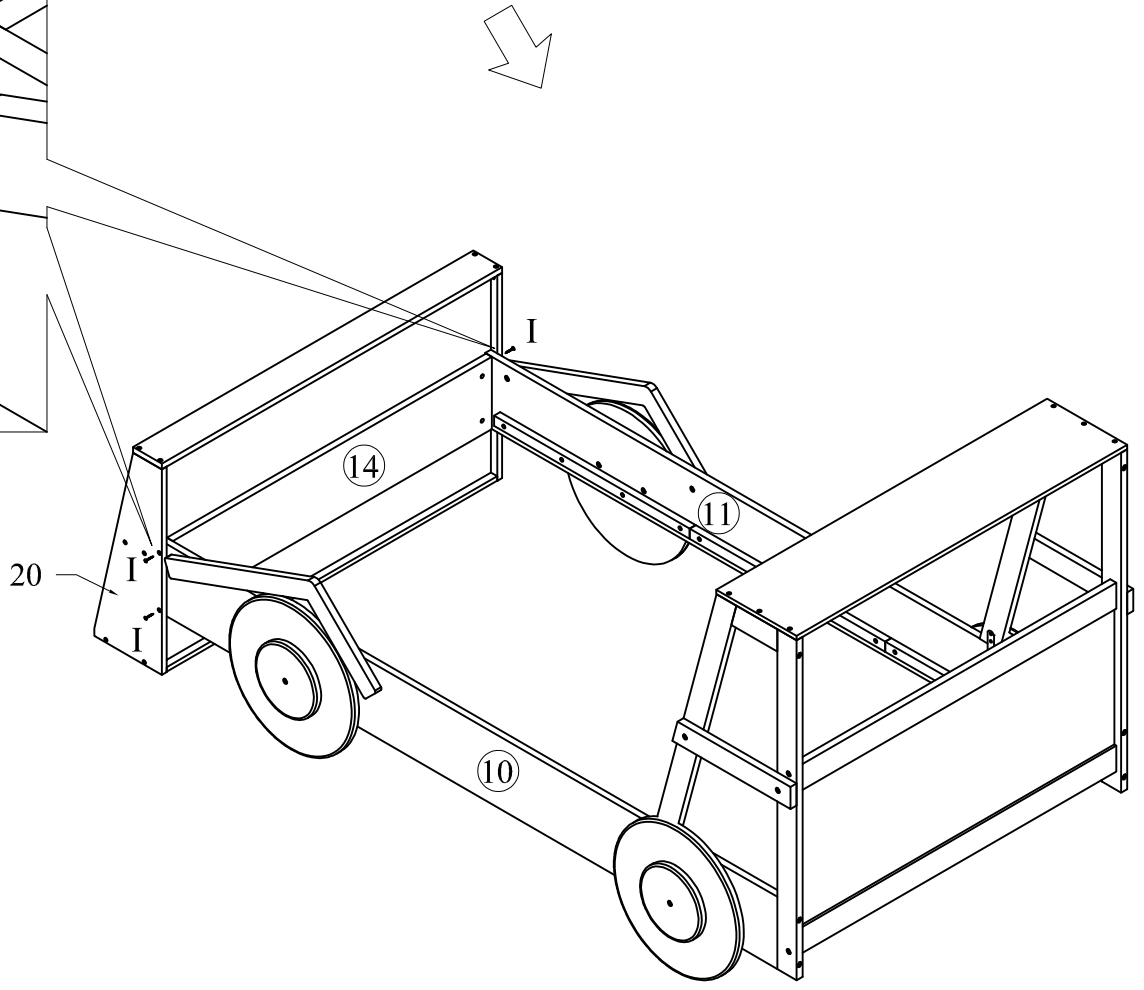
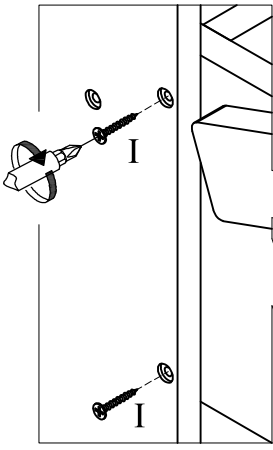
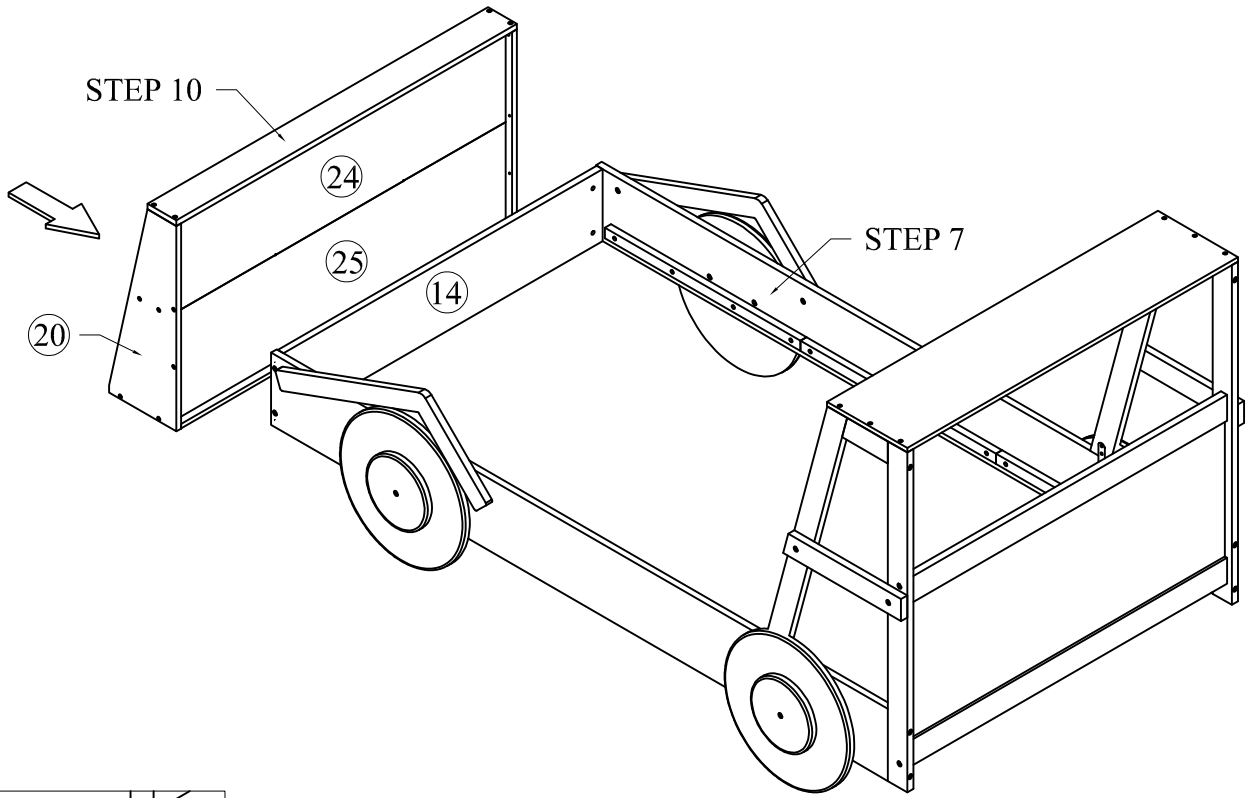

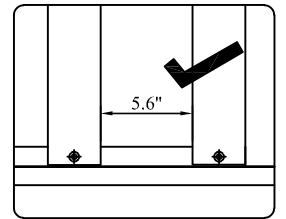
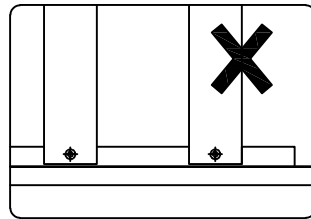
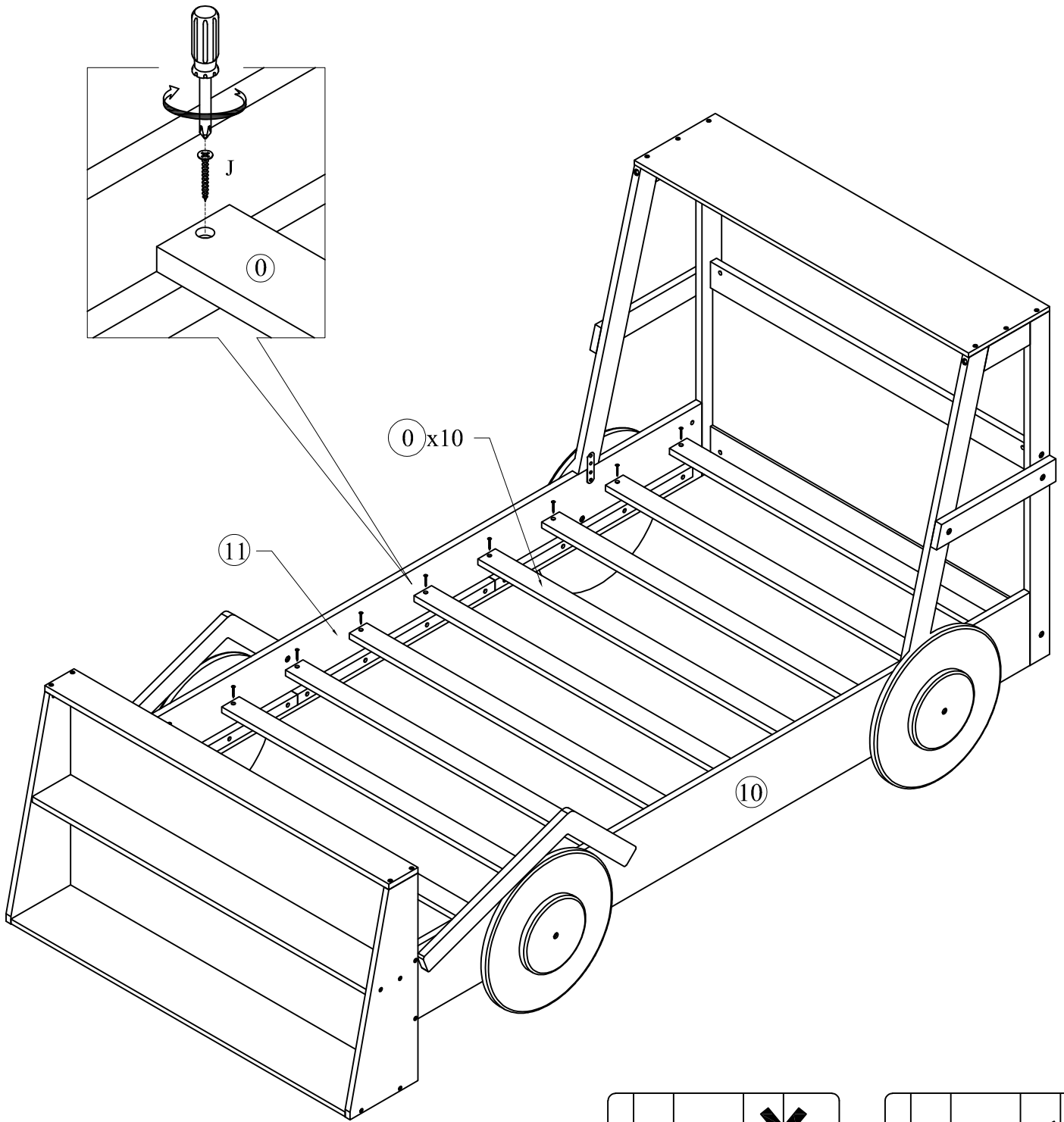

COMPLETED

