

Tour Life Style et Classique Life Style and Classic Storage Unit

Instructions d'assemblage
Assembly instructions

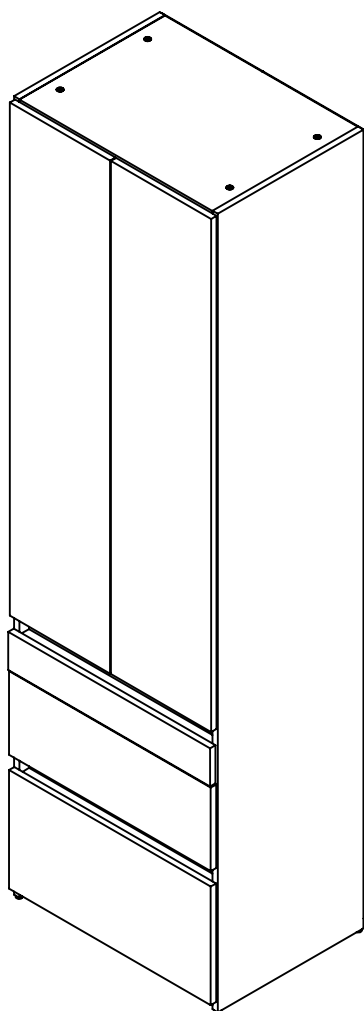

Modèle LifeStyle
LifeStyle Model

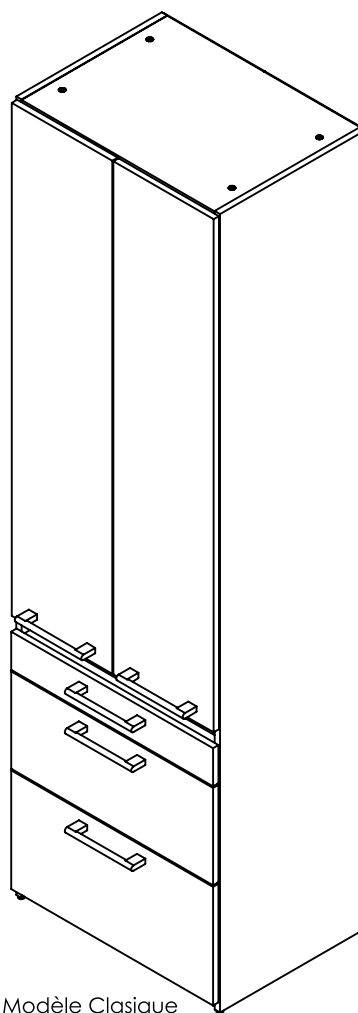

Modèle Clasique
Classic Model

**Lien vers guide interactif page 2 / Link to interactive guide page 2*

Pièces / Parts



Guide interactif
Interactive guide

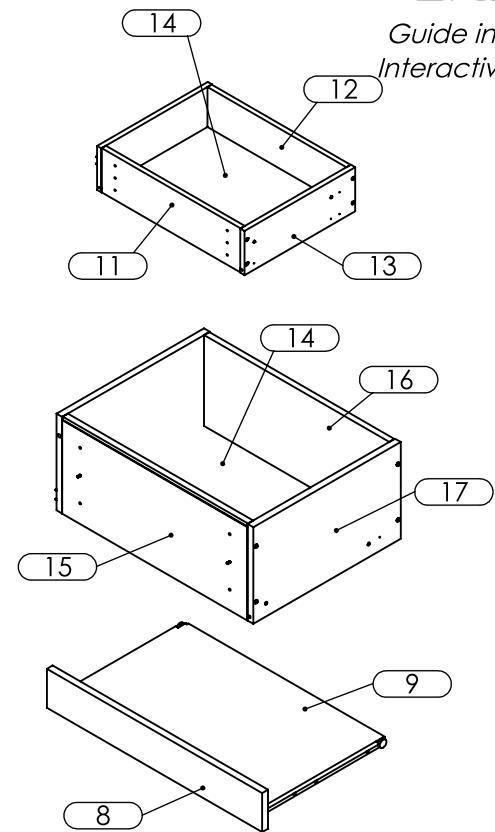
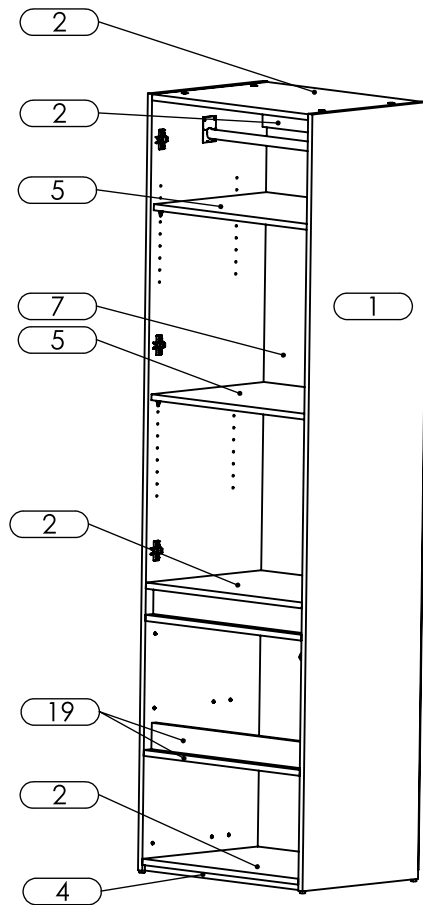
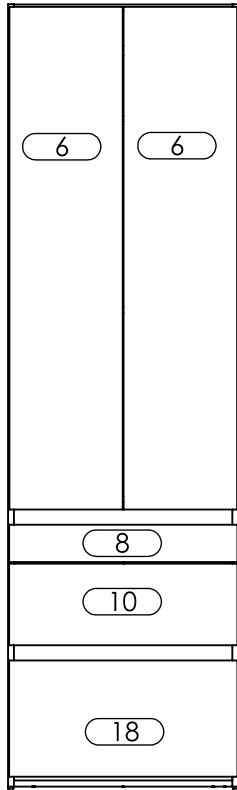

#	PIÈCE/PART	DESCRIPTION	QTÉ/QTY
1	CO-TOW-8118	Côté tour/ Storage unit side	2
2	TA-FX-24XX	Tablette fixe / Fixe shelf	3
3	TR-H-24XX	Traverse haute / Top rail	1
4	TR-B-24XX	Traverse basse / Bottom rail	2
5	TA-AJ-24XX	Tablette ajustable / Adjustable shelf	2
6	PO-HW-2481	Porte / Door	2
7	DOK-2481	Dos / Back	2
8	TFK-SEX-24XX	Façade tiroir service / service shelf facade	1
9	TA-SE-24XX	Tablette de service / Service shelf	1
10	TFK-WX-24XX	Façade tiroir multitâche / Multitask drawer facade	1
11	TAK-150-24XX	Avant tiroir multitâche / Multitask drawer front	1
12	TDK-150-24XX	Dos tiroir multitâche / Multitask drawer back	1
13	TCK-150-XXXX	Côté tiroir multitâche / Multitask drawer side	2
14	THK-24XX	HDF tiroir / HDF drawer	2
15	TAK-235-24XX	Avant tiroir classeur / File cabinet drawer front	1
16	TDK-235-XXXX	Dos tiroir classeur / File cabinet drawer back	1
17	TCK-235-XXXX	Côté tiroir classeur / File cabinet drawer side	2
18	TFK-CLX-24XX	Façade tiroir classeur / File cabinet drawer facade	1
19	T24-PW	Poignée / Handle	4

**? POUR TOUTE QUESTION /
FOR ANY QUESTION**







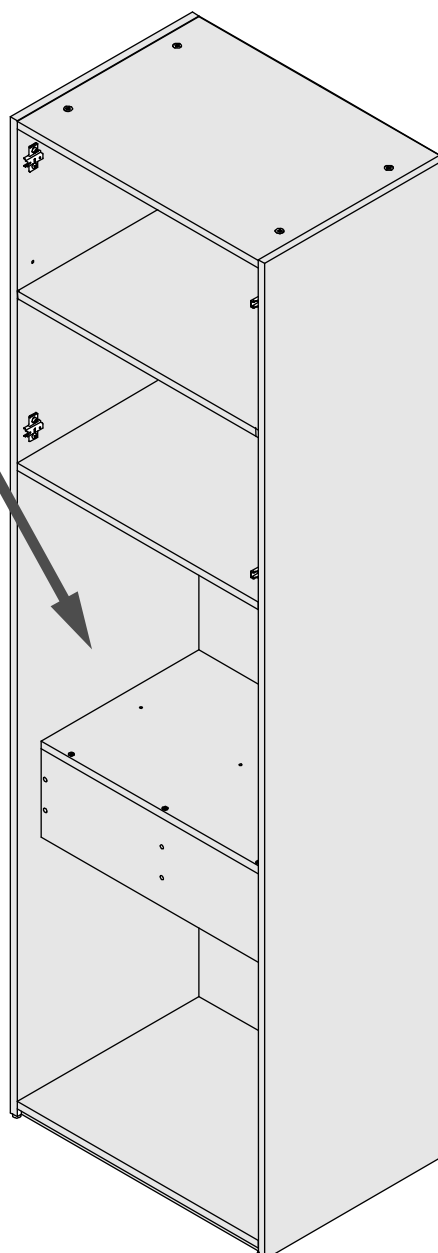



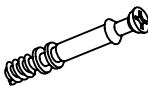
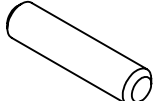

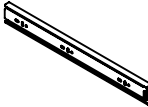



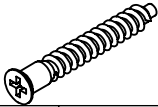

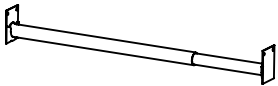

support@evolutek.ca

Votre caisson est déjà assemblé?
Passez à l'étape 8 !

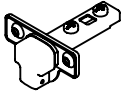

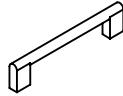



Your storage cabinet is already assembled?
Skip to step 8 !

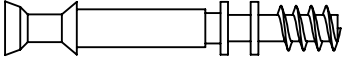
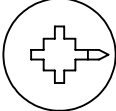

Liste de contrôle de la quincaillerie/ Hardware checklist

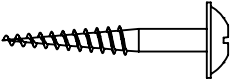
PIÈCE/PART	QTÉ/QTY	PIÈCE/PART	QTÉ/QTY	PIÈCE/PART	QTÉ/QTY
					
CAM-B-10	15	CAM-D-10X35MM	15	GOU-B-516X118	28
					
VIS-E-6mmx10	16	COU-14-BRU	2	COU-BL-16	4
					
PEN-PL-0MM	6	VIS-W-8X1	14	VIS-P-6X58	28
					
VIS-C-2	16	Ajusteur façade / Facade assembler	4	VIS-R-3X22MM	4
					
VIS-W-8X3	2	Clou/Nail	26	Support tablette / Shelf support	8
					
POL-1827	1	PAT-CLOU	4	PEN-26MM	6
					
GOU-P- 8mmX35mm	2	POI-RO-160mm *Classique seulement/ Classic only	5	VIS-R-M3x22	10
					
VIS-W-8X118	4	Moulure/Molding	2		

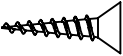
Quincaillerie taille réelle / Full-size hardware

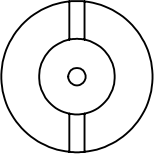
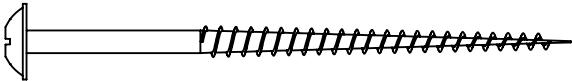
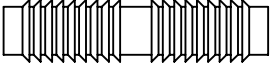
 <p><i>CAM-D-10X35MM DOUILLE SOCKET</i></p>	 <p><i>CAM-B-10 CAME CAM</i></p>	 <p><i>GOU-B-516X118 GOUJON DE BOIS WOOD DOWEL</i></p>
 <p><i>VIS-C-2 VIS D'ASSEMBLAGE 2" ASSEMBLY SCREW 2"</i></p>	 <p><i>VIS-W-8X1 VIS TÊTE RONDELLE #8X1" WASHER HEAD SCREW</i></p>	 <p><i>VIS-E-6MMX10 VIS EURO EURO SCREW</i></p>
 <p><i>VIS-P-6X58 VIS TÊTE PLATE #6X5/8" FLATHEAD SCREW</i></p>	 <p><i>VIS-R-3X22MM VIS TÊTE RONDE M3 ROUNDHEAD SCREW</i></p>	 <p><i>AJUSTEUR DE FAÇADE FACADE ASSEMBLER</i></p>
 <p><i>VIS-W-8X212 VIS TÊTE RONDELLE #8X2 1/2" WASHER HEAD SCREW</i></p>		 <p><i>GOU-P-8mmX35mm GOUJON PLASTIQUE 8mmX35mm PLASTIC DOWEL</i></p>

Remarques particulières / Special remarks

Outils requis / Reuired tools

-Marteau / Hammer

-Tournevis Robertson #1, 2, 3 et plat / Robertson screwdriver #1,2,3 and flathead

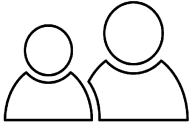

Deux personnes sont requises pour l'assemblage de ce meuble.
Two people are required to assemble this unit.

Séparation des coulisses à billes / Separation of ball-bearing rails

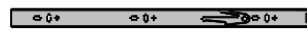
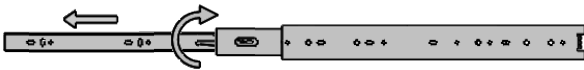

Installer sur tiroir
Set up on drawer



Installer sur caisson
Set up on cabinet (3)

Assemblage par came et goujon / Cam and dowel assembly

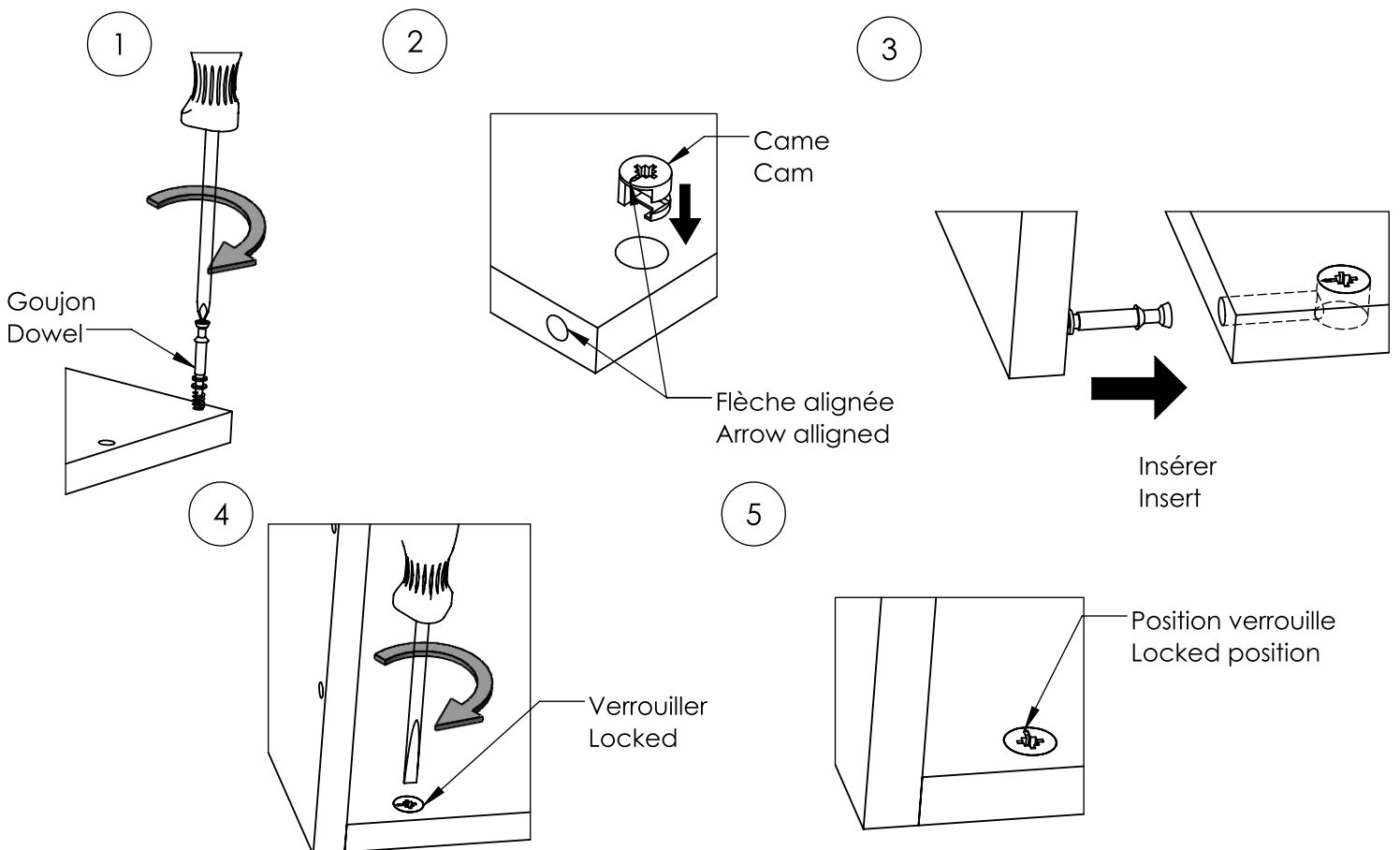

1- Installation des coulisses / Installing rails



PIÈCE/PART	VIS-E-6MMX10	COU-14-BRU-EXT	COU-BL-16-EXT
QTÉ/QTY	16	2	4

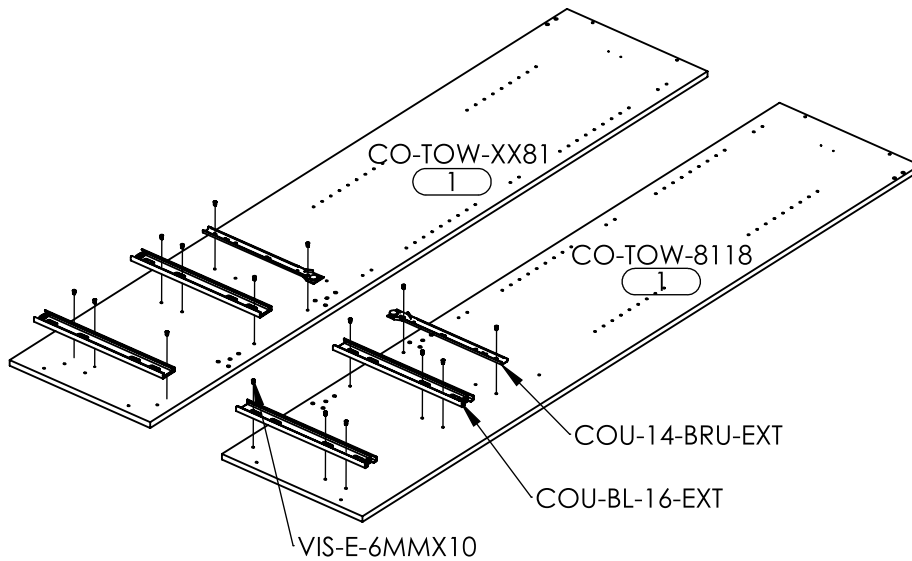

2- Installation des douilles / Installing socket



PIÈCE/PART	CAM-D-10X35mm
QTÉ/QTY	12

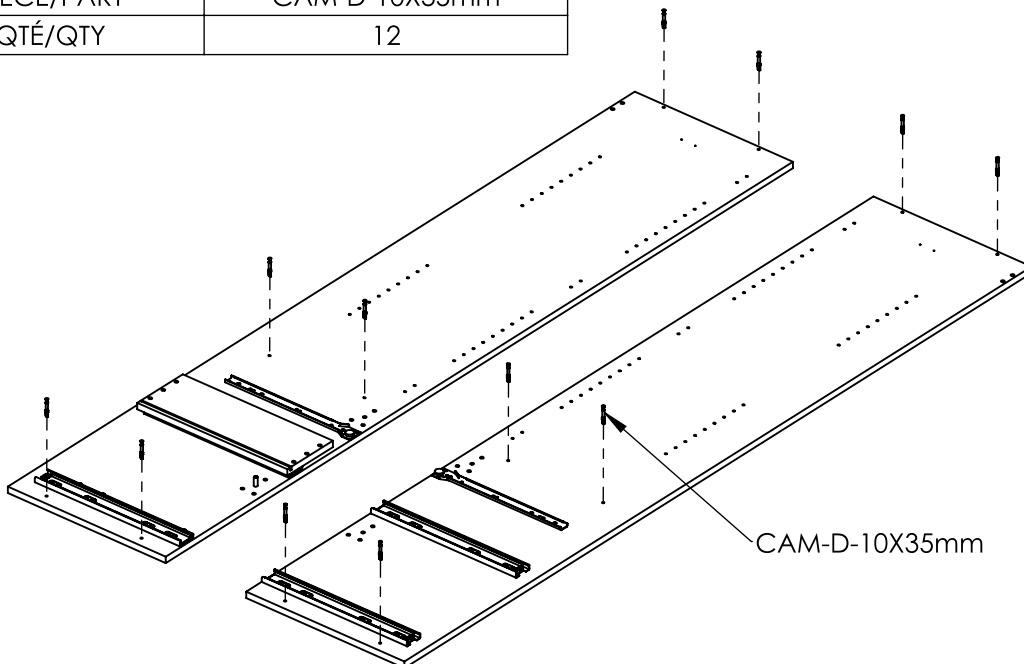

3- Installation des plaques de penture / Installing hinge plates

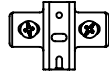

PIÈCE/PART	PEN-PL-0mm
QTÉ/QTY	6

**Important*

Ne pas trop serrer les vis pour que la plaque puisse se déplacer

Do not tighten the screws too much so that the plate can move

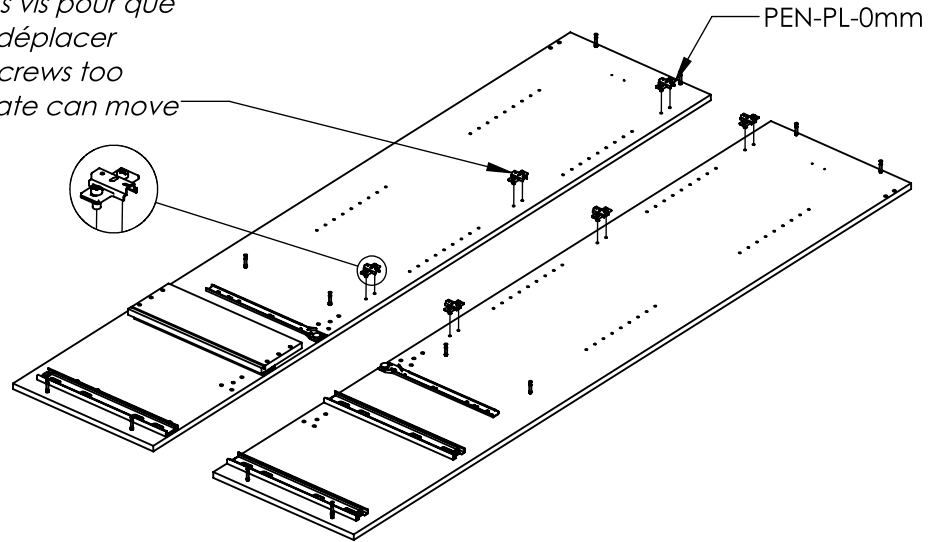

4- Installation des goujons / Installing dowels



PIÈCE/PART	GOU-B-516X118
QTÉ/QTY	20

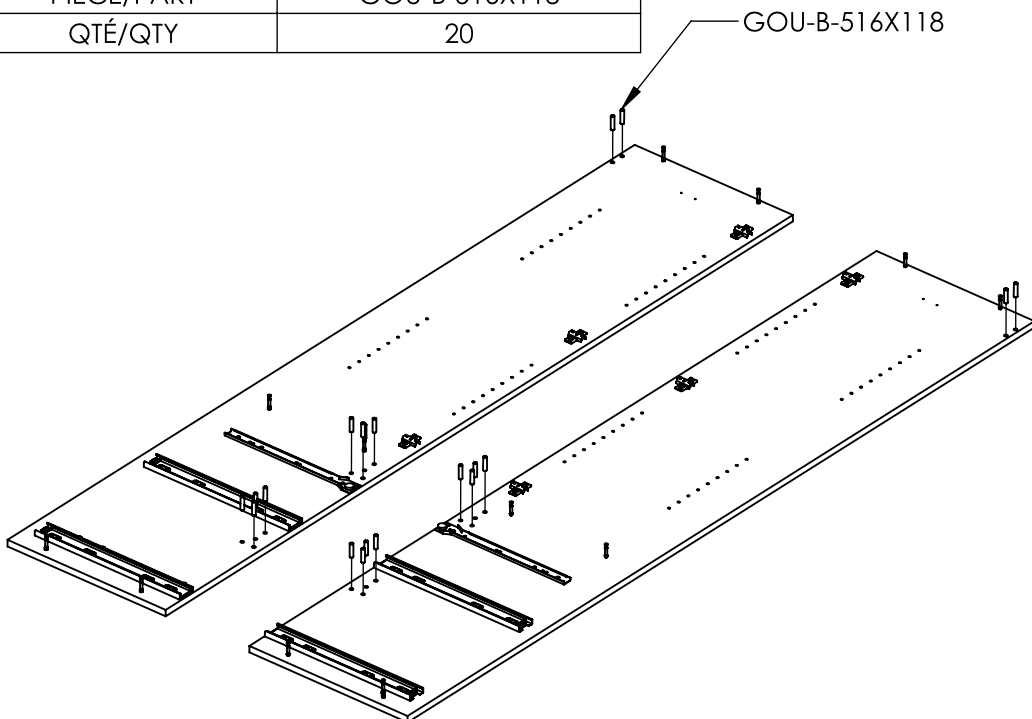

5- Assemblage de la tour / Assembling the unit



PIÈCE/PART	CAM-B-10	GOU-P-8mmX35mm
QTÉ/QTY	6	2

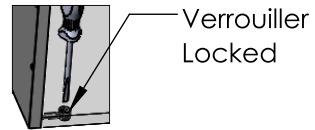
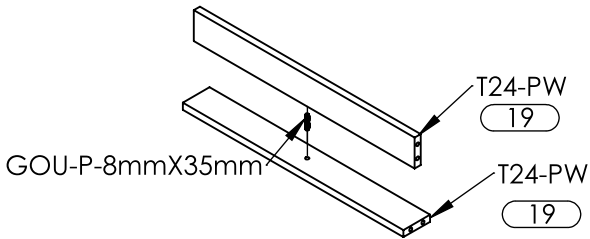

Pré-assemblage de la poignée (X2)
Pre-assembling the handle

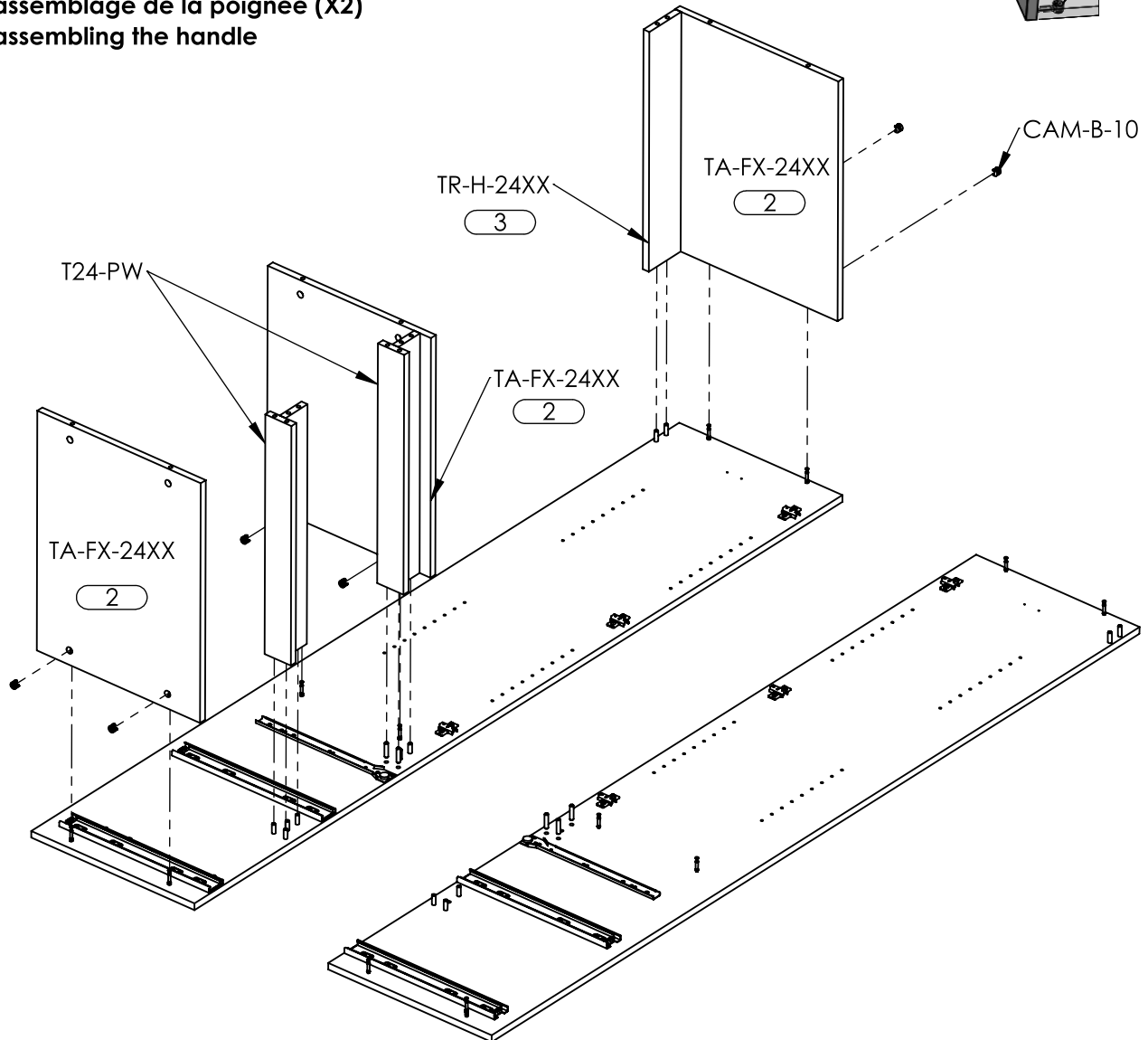

5B- Assemblage de la tour / Assembling the unit



PIÈCE/PART	CAM-B-10
QTÉ/QTY	6

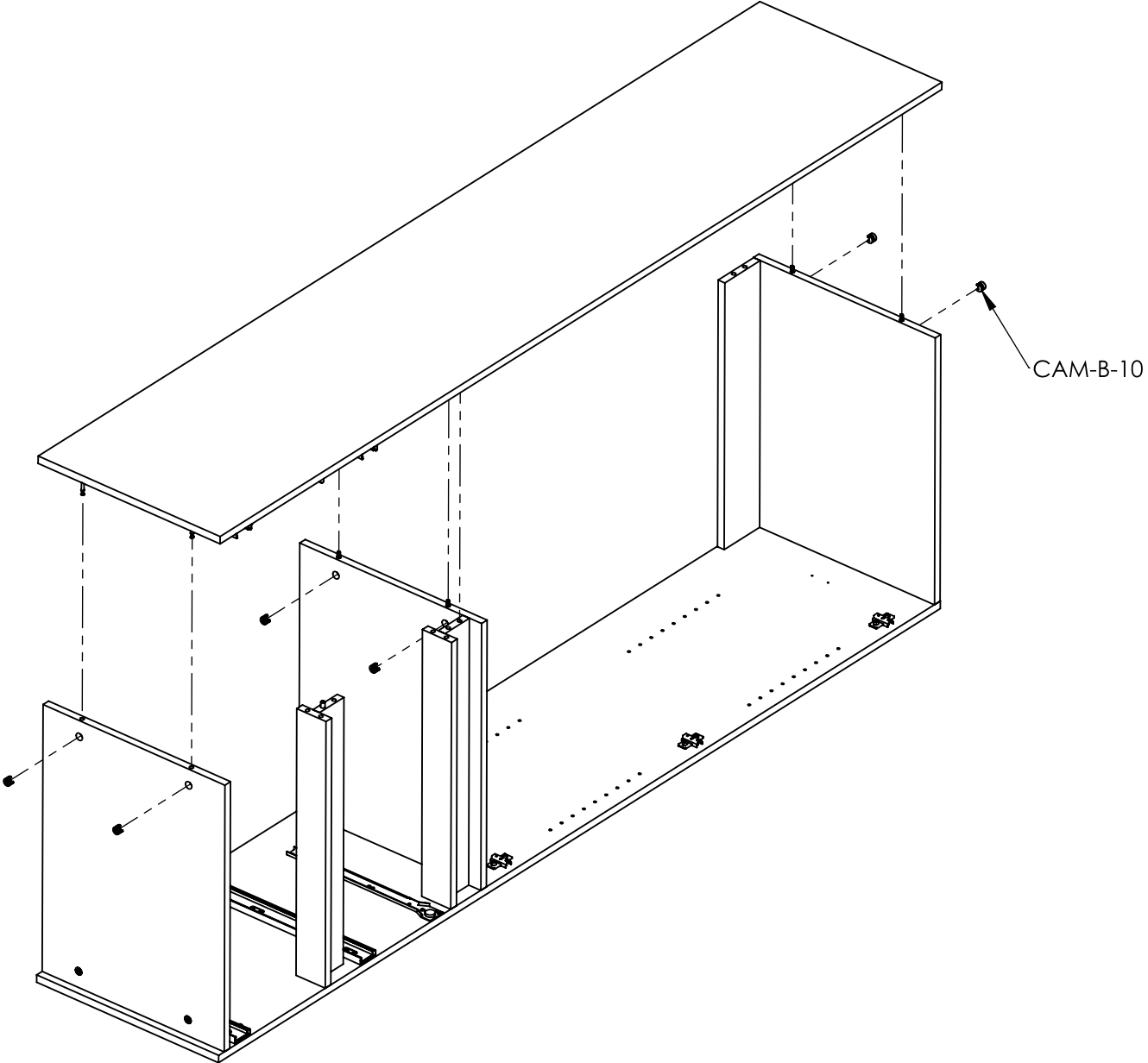
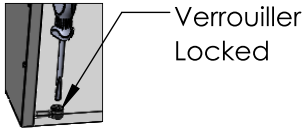

6- Installation des traverses du bas / Installing bottom rail



PIÈCE/PART	VIS-W-8X1	PAT-CL-58
QTÉ/QTY	6	4

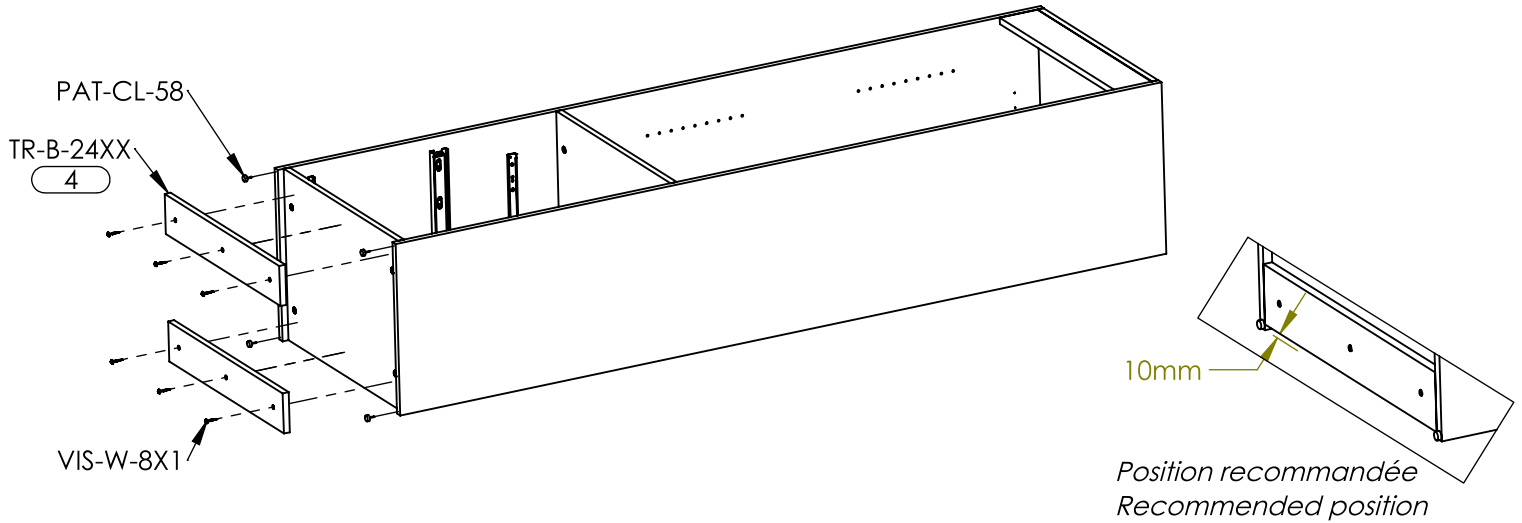

7- Assemblage Dos / Assembling back

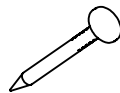

PIÈCE/PART	Clou/Nail
QTÉ/QTY	26

DOK-2481
7

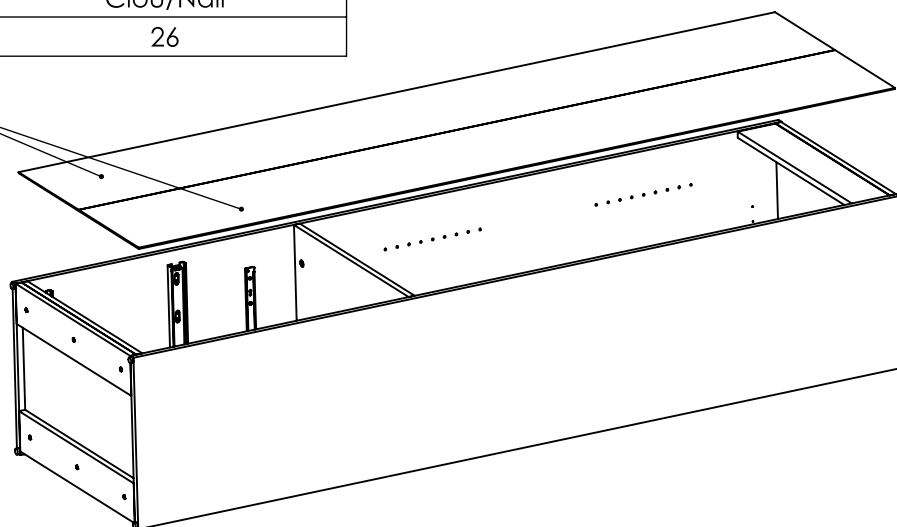

8- Assemblage tiroir classeur / Assembling file cabinet drawer

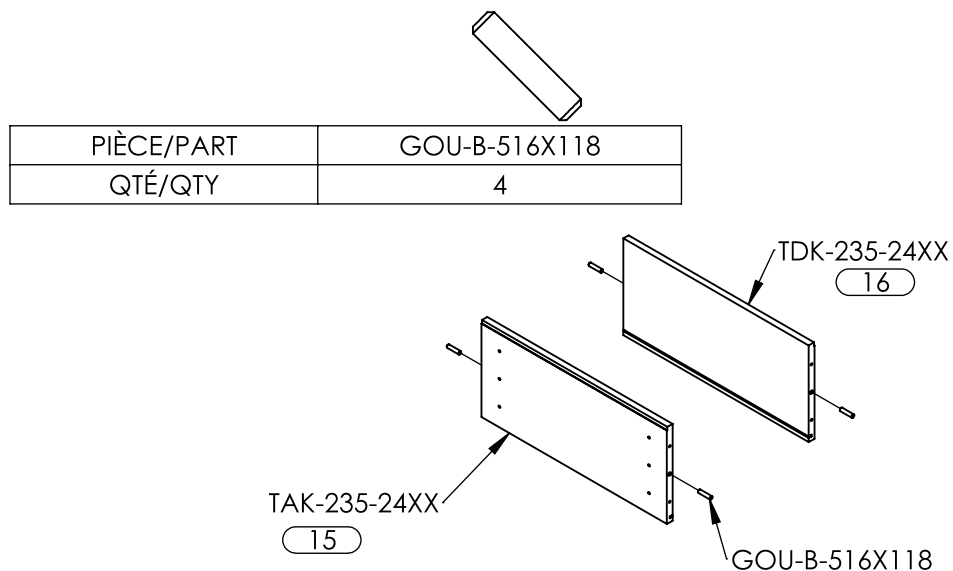

9- Assemblage tiroir classeur / Assembling file cabinet drawer

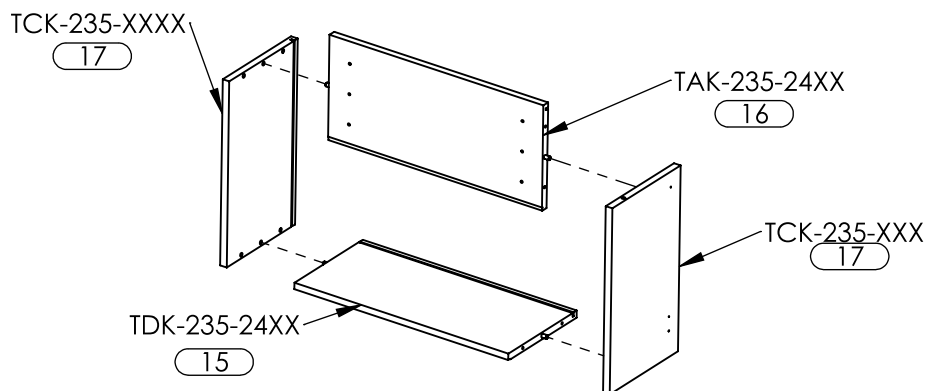

10- Assemblage tiroir classeur / Assembling file cabinet drawer

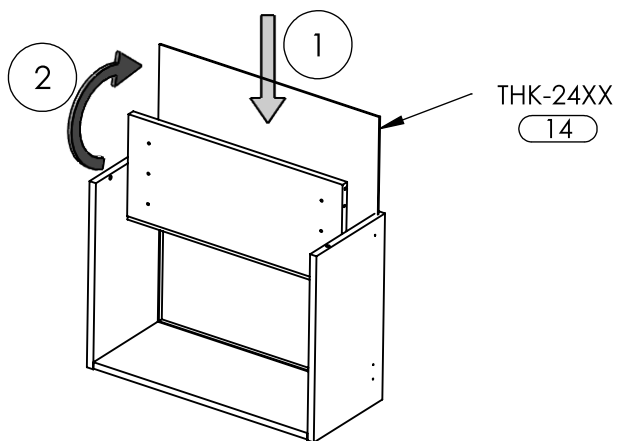

11- Assemblage tiroir classeur / Assembling file cabinet drawer

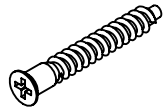

PIÈCE/PART	VIS-C-2
QTÉ/QTY	8

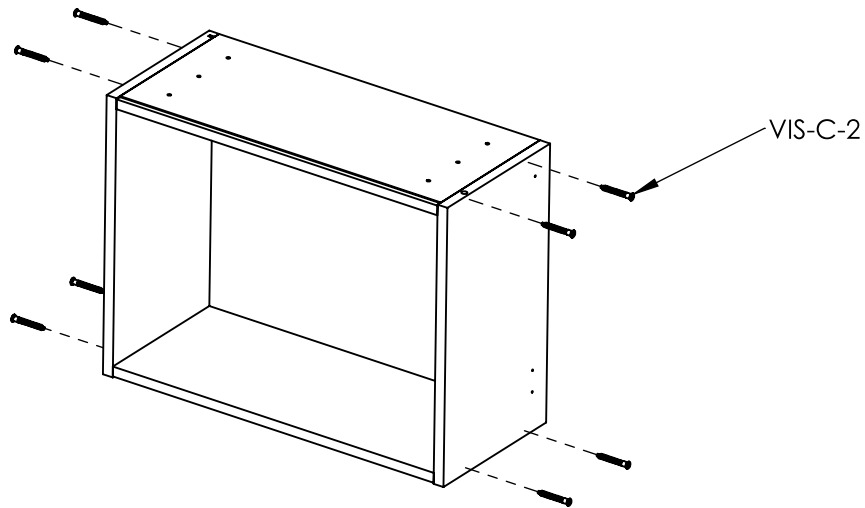

12- Assemblage tiroir classeur / Assembling file cabinet drawer

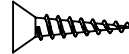
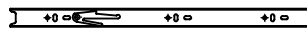

PIÈCE/PART	COU-BL-16-INT	VIS-P-6X58
QTÉ/QTY	2	4

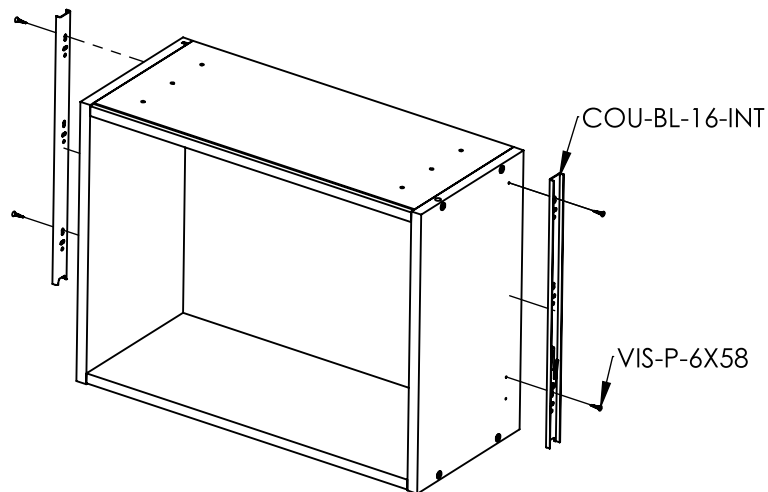

13- Assemblage tiroir classeur / Assembling file cabinet drawer



PIÈCE/PART	Ajusteur façade / Facade assembler	VIS-R-3x22MM
QTÉ/QTY	2	2

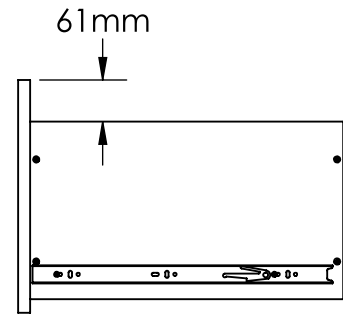
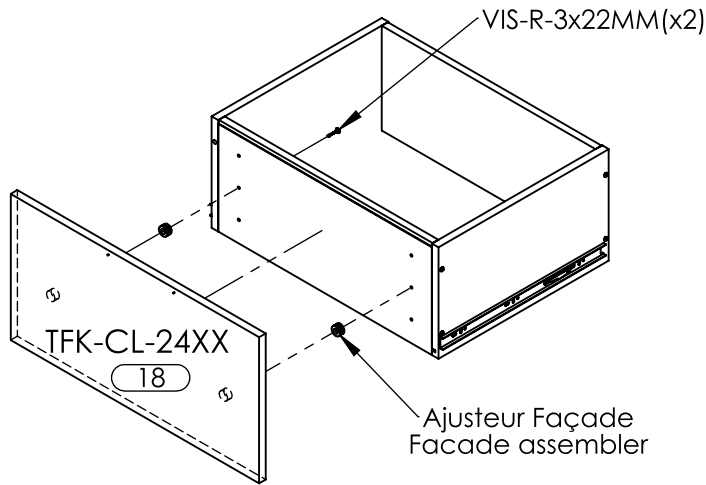

Position façade assemblée /
Assembled facade position

14- Assemblage tablette de service / Assembling service shelf

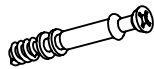

PIÈCE/PART	CAM-D-10X35MM
QTÉ/QTY	3

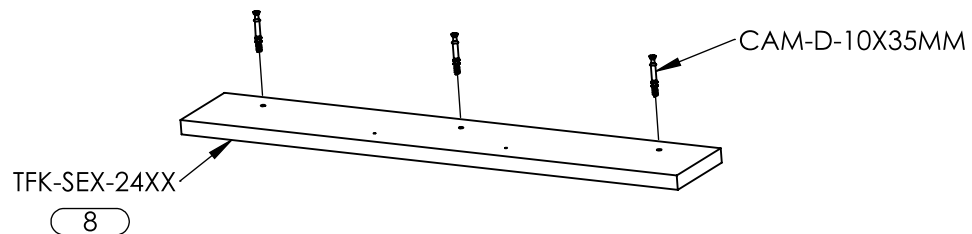

15- Assemblage tablette de service/Assembling service shelf



PIÈCE/PART	VIS-P-6X58	COU-BRU-14-INT
QTÉ/QTY	4	2

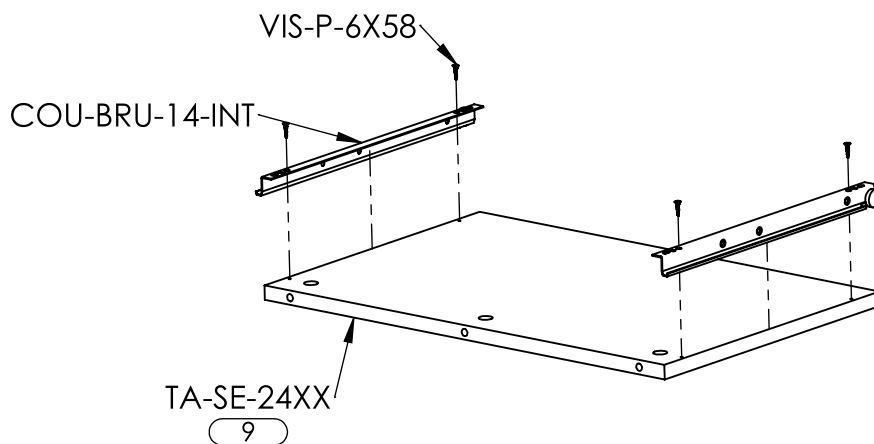

16- Assemblage tablette de service / Assembling service shelf



PIÈCE/PART	CAM-B-10
QTÉ/QTY	3

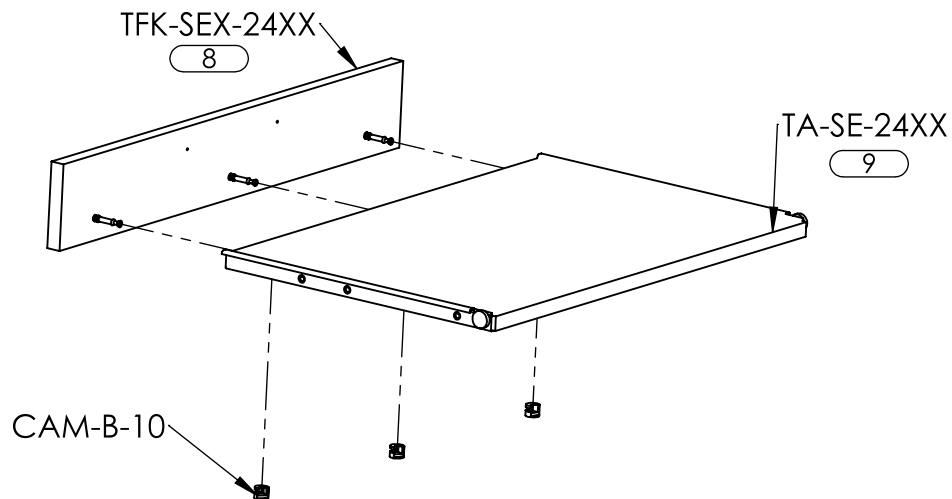

17- Assemblage tiroir multitâche / Assembling multitask drawer

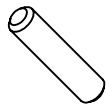

PIÈCE/PART	GOU-B-516x118
QTÉ/QTY	4

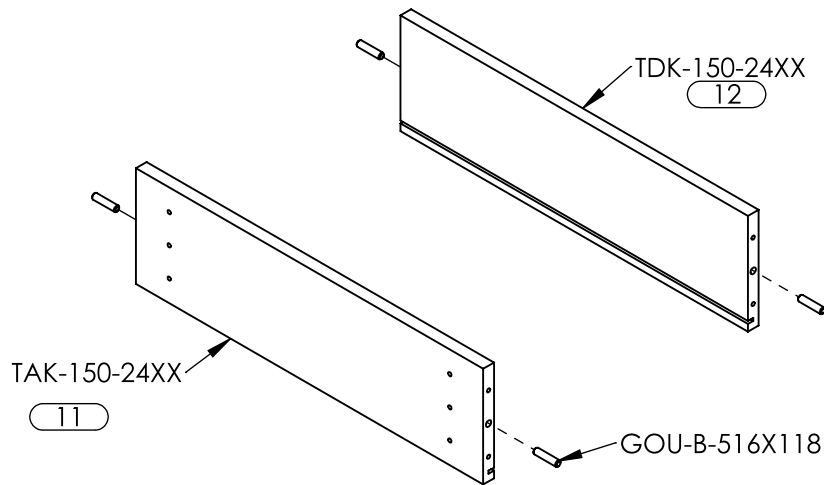

18- Assemblage tiroir multitâche / Assembling multitask drawer

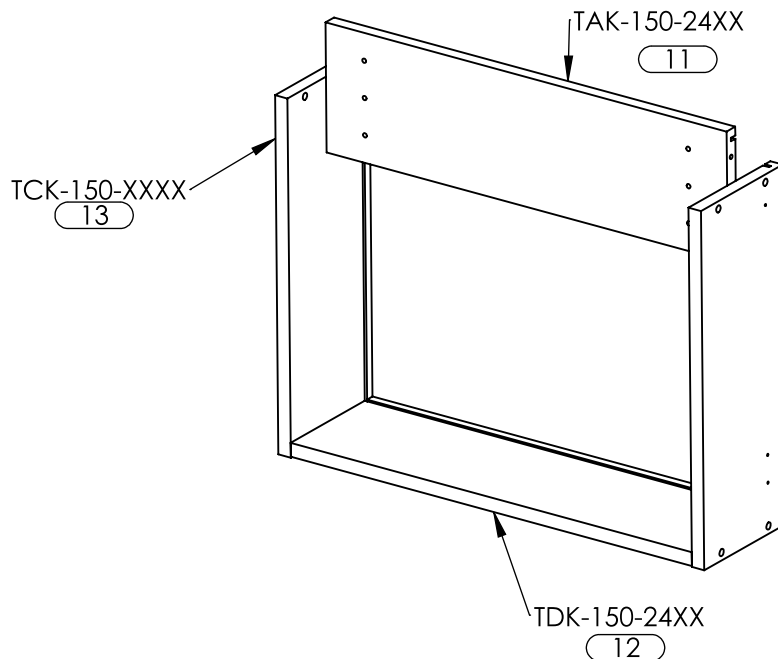

19- Assemblage tiroir multitâche / Assembling multitask drawer

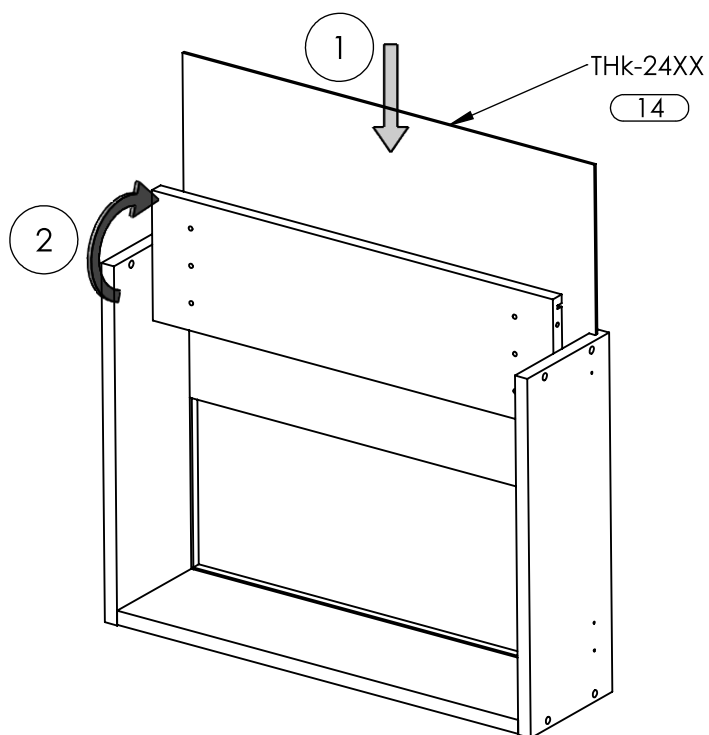

20- Assemblage tiroir multitâche / Assembling multitask drawer

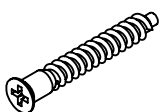

PIÈCE/PART	VIS-C-2
QTÉ/PART	8

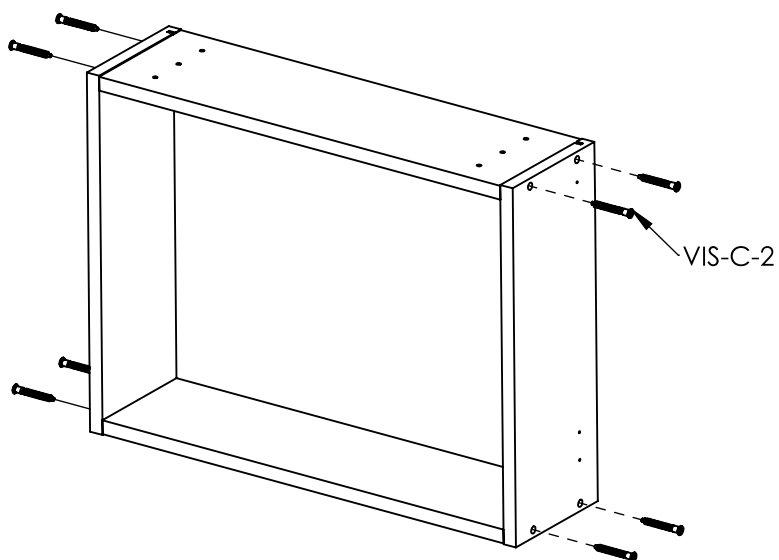

21- Assemblage tiroir multitâche / Assembling multitask drawer



PIÈCE/PART	COU-B-16-INT	VIS-P-6X58
QTÉ/PART	2	4

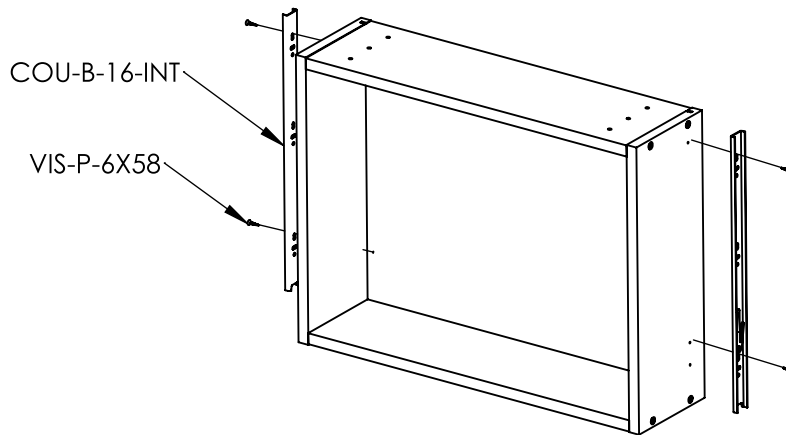

22- Assemblage tiroir multitâche / Assembling multitask drawer



PIÈCE/PART	Ajusteur façade/Facade ajuster	VIS-R-3x22MM
QTÉ/QTY	2	2

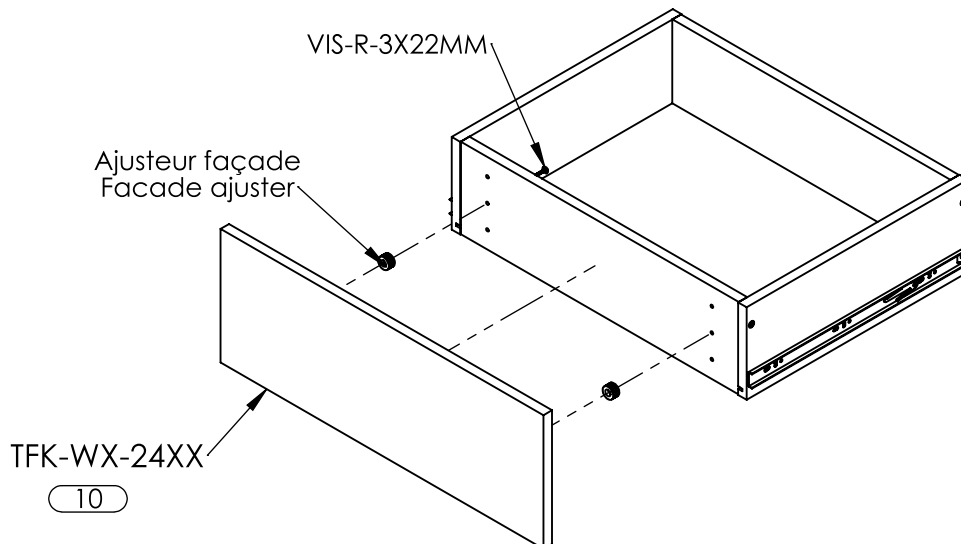

Position façade assemblée/
Assembled facade position

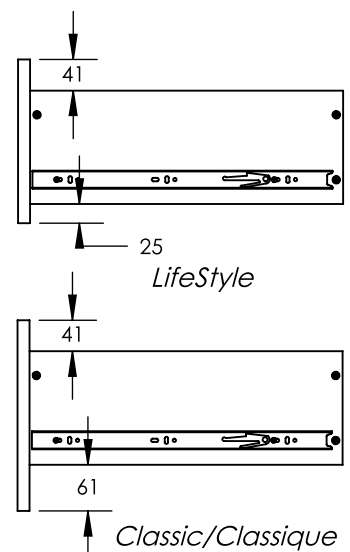

10

23- Assemblage tablettes ajustables / Adjusting the adjustable shelf



PIÈCE/PART	Support de tablette/ Shelf support
QTÉ/QTY	8

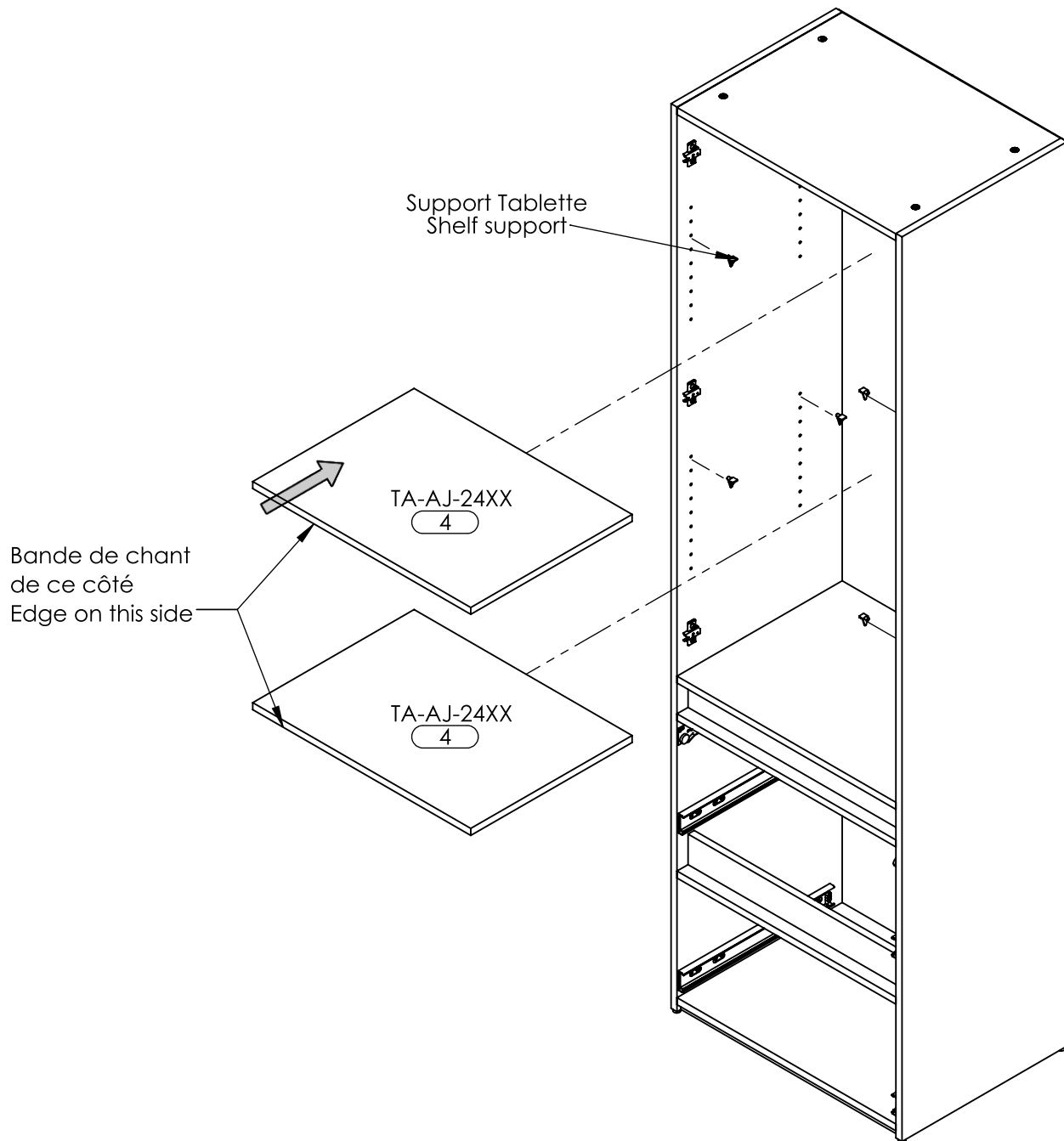

24- Assemblage de la pôle / Assembling the pole

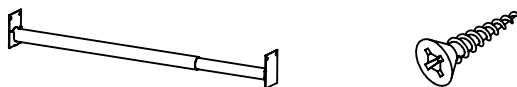

PIÈCE/PART	POL-1827	VIS-P-6X58
QTÉ/QTY	1	4

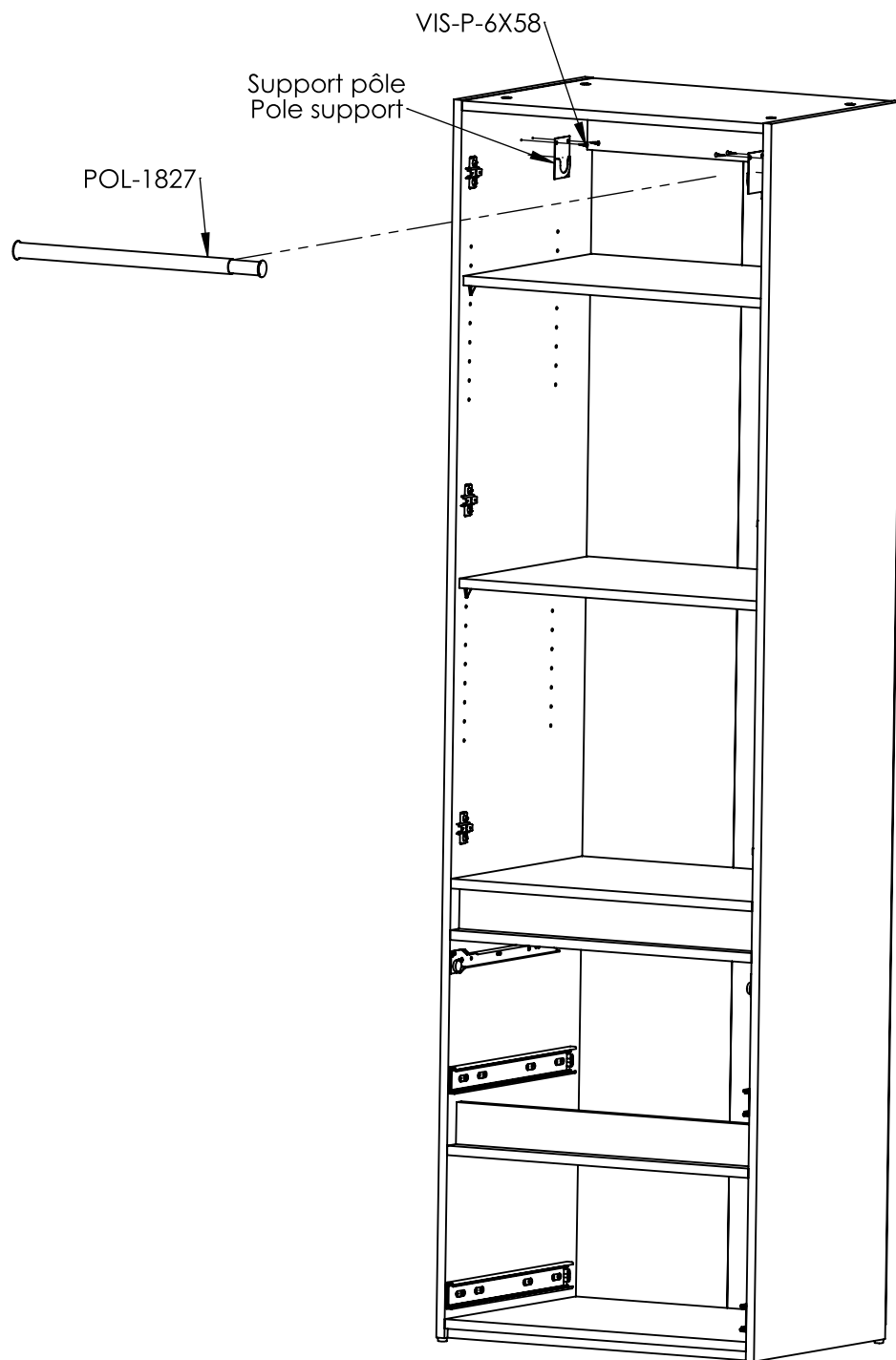

25- Assemblage des portes / Assembling the doors

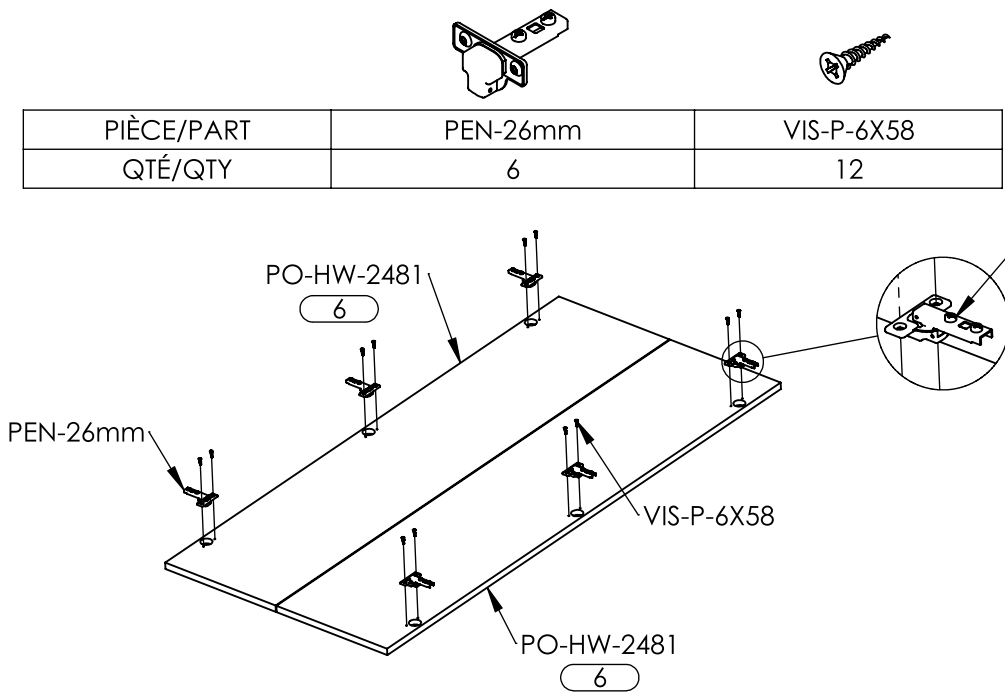

26- Assemblage des portes / Assembling the doors X2

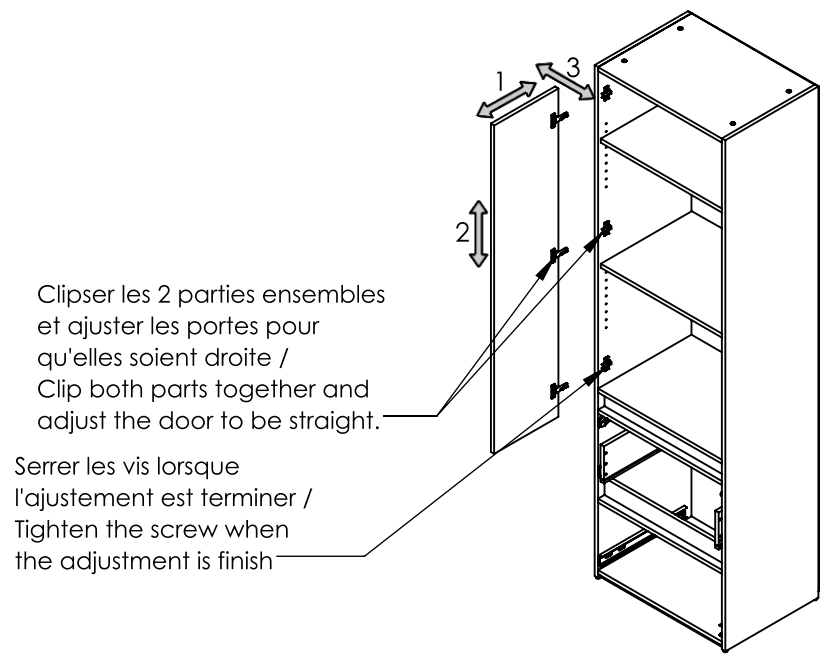

Ajustement / Adjustment

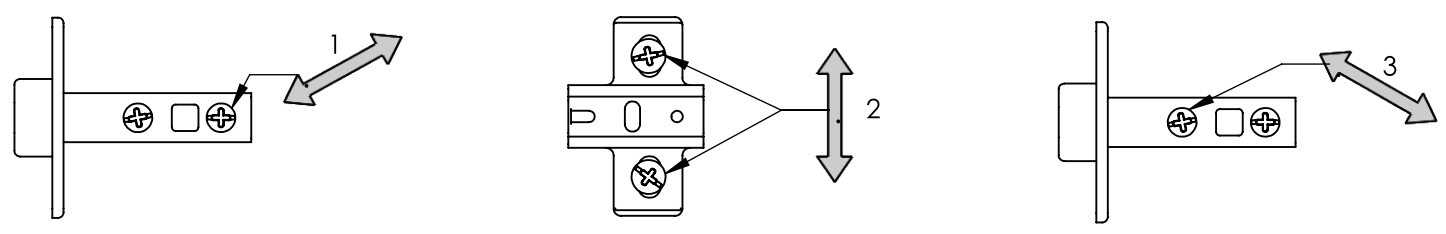

27- Installation des tiroirs / Installing the drawers

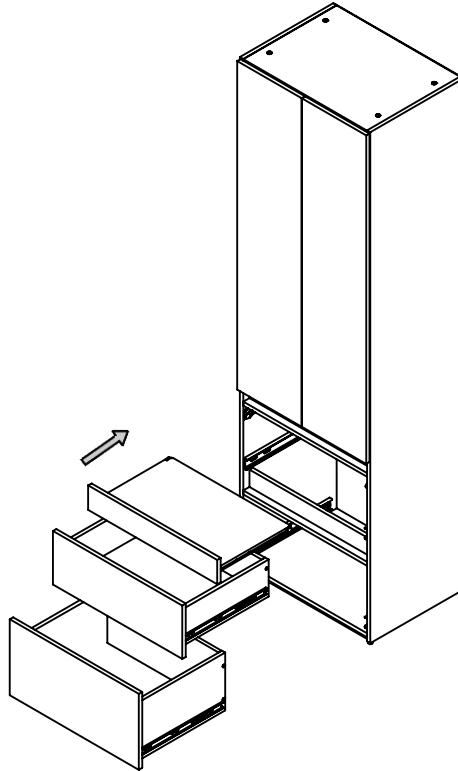

28- Ajustement et fixation des façades / Adjusting and fixing the facade



PIÈCE/PART	VIS-W-8X1
QTÉ/QTY	8

*Ajuster les façades des 3 tiroirs de sorte à ce qu'elles soient droites. Lorsqu'elles sont ajustées, fixer les façades avec 4 vis par façade.
Adjust the fronts of the 3 drawers so they are straight. Once adjusted, fix them with 4 screws by facade

VIS-W-8X1 (X8)

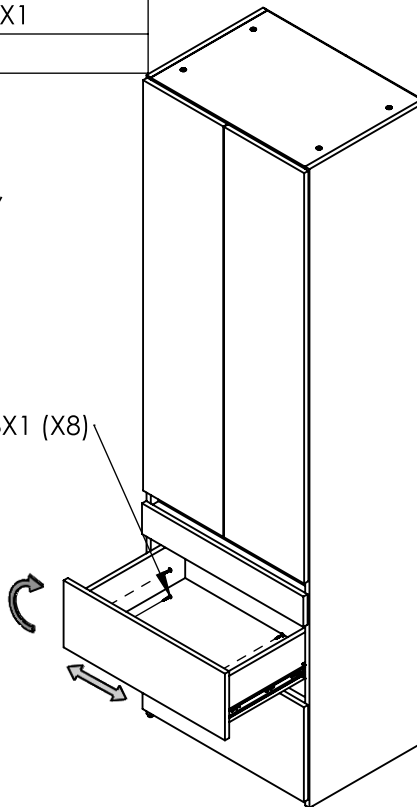

29- Installation des poignées / Installing the handles

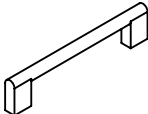

PIÈCE/PART	POI-RO-160mm	VIS-R-M3x22
QTÉ/QTY	5	10

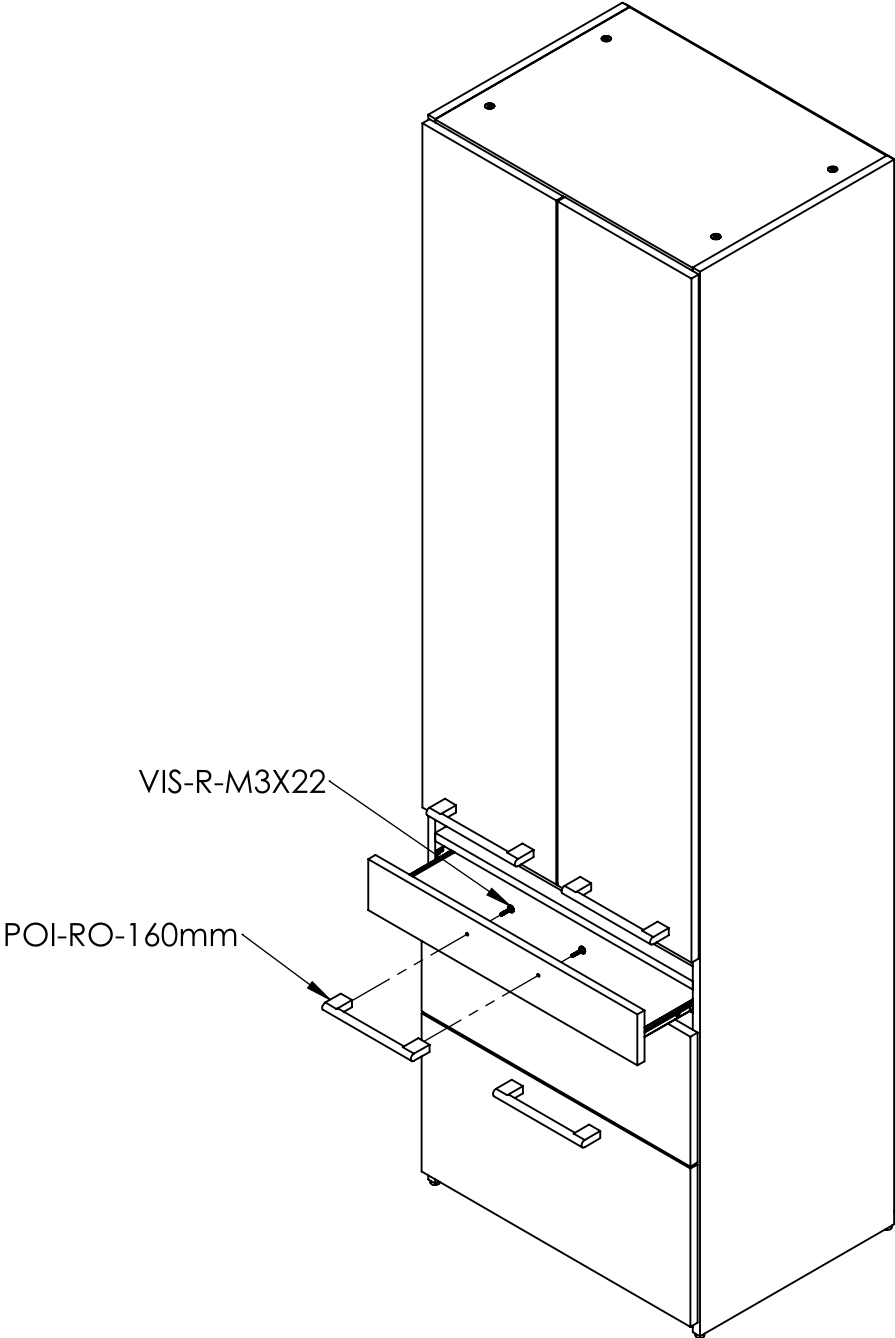

30- Fixer tour au lit si applicable / Fixing unit to the bed if applicable



PIÈCE/PART	VIS-W-8X118
QTÉ/QTY	4

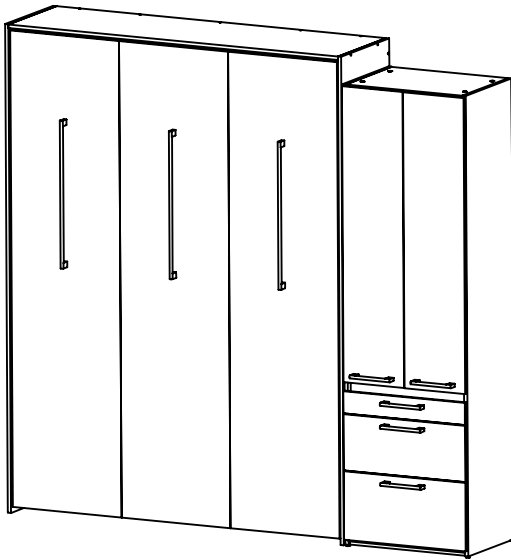

Placer la tour à côté du lit/
Place unit next to the bed

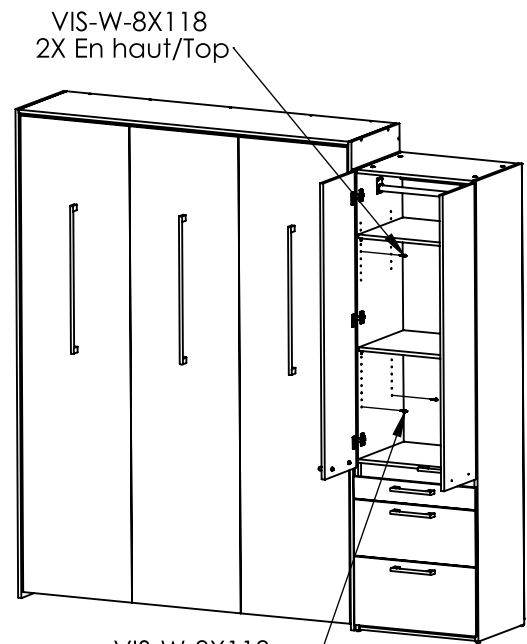

VIS-W-8X118
2X En haut/Top

VIS-W-8X118
2X En bas/Bottom

Enutilisant le trous des tablettes ajustables, visser la tour au lit./ Using the holes of the adjustable shelves, screw the tower to the bed.



AVERTISSEMENT / WARNING

Risque de blessures graves ou mortelles par écrasement en cas de chute du meuble.

Pour éviter tout risque de basculement, ce meuble doit être fixé au mur. Les vis incluses sont pour les murs avec montants de bois. Pour toutes autres compositions murales, utiliser des vis et des chevilles adaptées à votre type de mur. En cas de doute, demander conseil à un professionnel.

Risk of serious injuries or death from being crushed by the furniture falls.

To avoid any risk of tipping, the furniture must be fixed to the wall. The screws included are for walls with wood studs. For all other wall compositions, use screws or anchors adapted to your type of wall. If unsure, ask a professional for advice.

31- Installation tour au mur / Installing unit to the wall



PIÈCE/PART	VIS-W-8X212
QTÉ/QTY	2

