

# Installation Instruction

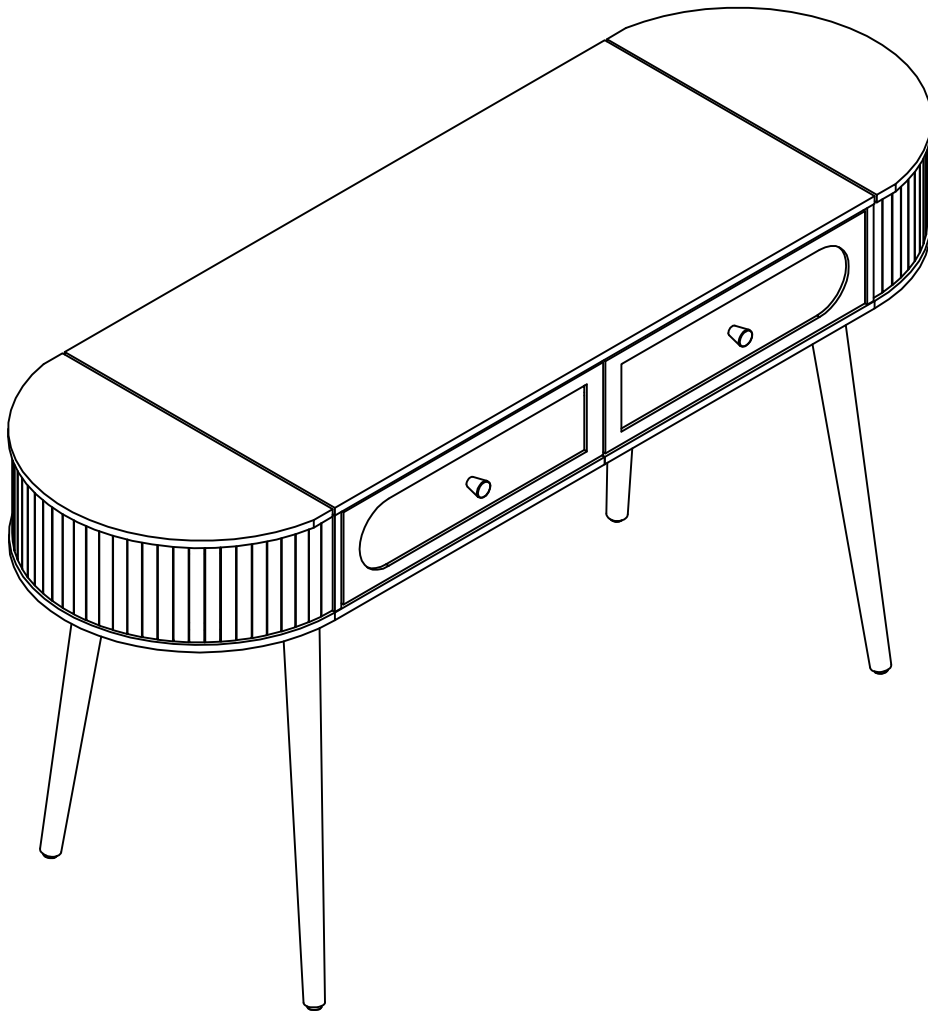

# Assembling

## What you need

- Use the packaging carton as a working surface to prevent product damage during assembly
- Phillips head screwdriver

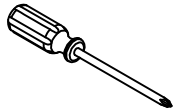

## Weight Limitation



**100**

lbs table top

**| 35**

lbs per

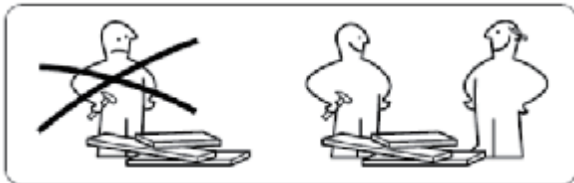

# What' included

Code	Description	Qty
A	Cam Bolt M6X35MM	16
B	Cam Lock 15X10MM	16
C	Wooden Dowel M8X30MM	15
D	Screw M4X40MM	17
E	Screw M3.5X12MM	2
F	Screw M6X25MM	4
G	Nylon Strap	2
H	Screw M3.0X12MM	54
I	Cam Bolt M4X12MM	2
J	Plastic Angle code	6
K	Anchor	2
L	Adjustable foot	4
M	Hole position sticker	16
N	Metal handhandle	2
O	Wrench M4X55MM	1
P	Screw M6X48MM	12
Q	Screw M6X30MM	12
R	Hinge	4
CL	Left mother extended orbit	2
CR	Right mother extended orbit	2
DL	Left public extension track	2
DR	Right public extends track	2

# The Hardwares

Ⓐ

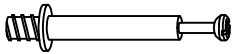

Ⓑ



Ⓒ



Ⓓ

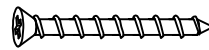

Ⓔ



Ⓕ



Ⓖ

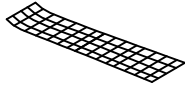

Ⓗ



Ⓘ



Ⓙ

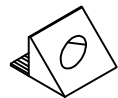

Ⓚ



Ⓛ

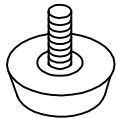

Ⓜ

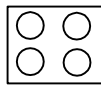

Ⓝ

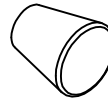

Ⓞ



Ⓟ



Ⓠ



Ⓡ

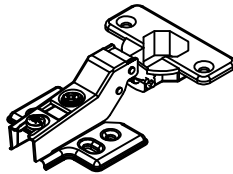

ⒸⓁ

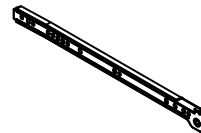

ⒸⓇ

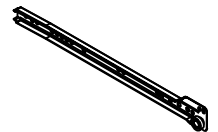

ⒹⓁ



ⒹⓇ

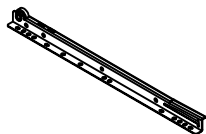

## IMPORTANT:

1. Do not tighten bolts / screws completely until all bolts / screws are lined up and inserted into holes.
2. Do not over tighten screws and bolts to avoid stripping
3. Please use hand tools to assemble this product, you can also use power tools (please use power tools carefully).

# Included Accessories

---

Code	Description	Qty
1	Cabinet Top	1
2	Left Bottom Panel	1
3	Left Side Panel	1
4	Right Side Panel	1
5	Median septum plate	1
6	Drawer left side panel	2
7	Drawer right side panel	2
8	The drawer bottom	1
9	After the drawer board	1
10	Drawer panel	1
11	Drawer panel	1
12	The drawer bottom	1
13	After the drawer board	1
14	The door	2
15	Back brace	1
16	Right Bottom Panel	1

# Included Accessories



---

Code	Description	Qty
17	Coaming panel	2
18	Left and right metal feet	2
19	Connecting rod	1
20	Arc-shaped side frame	4
21	Support rod	4
22	Support rod	2

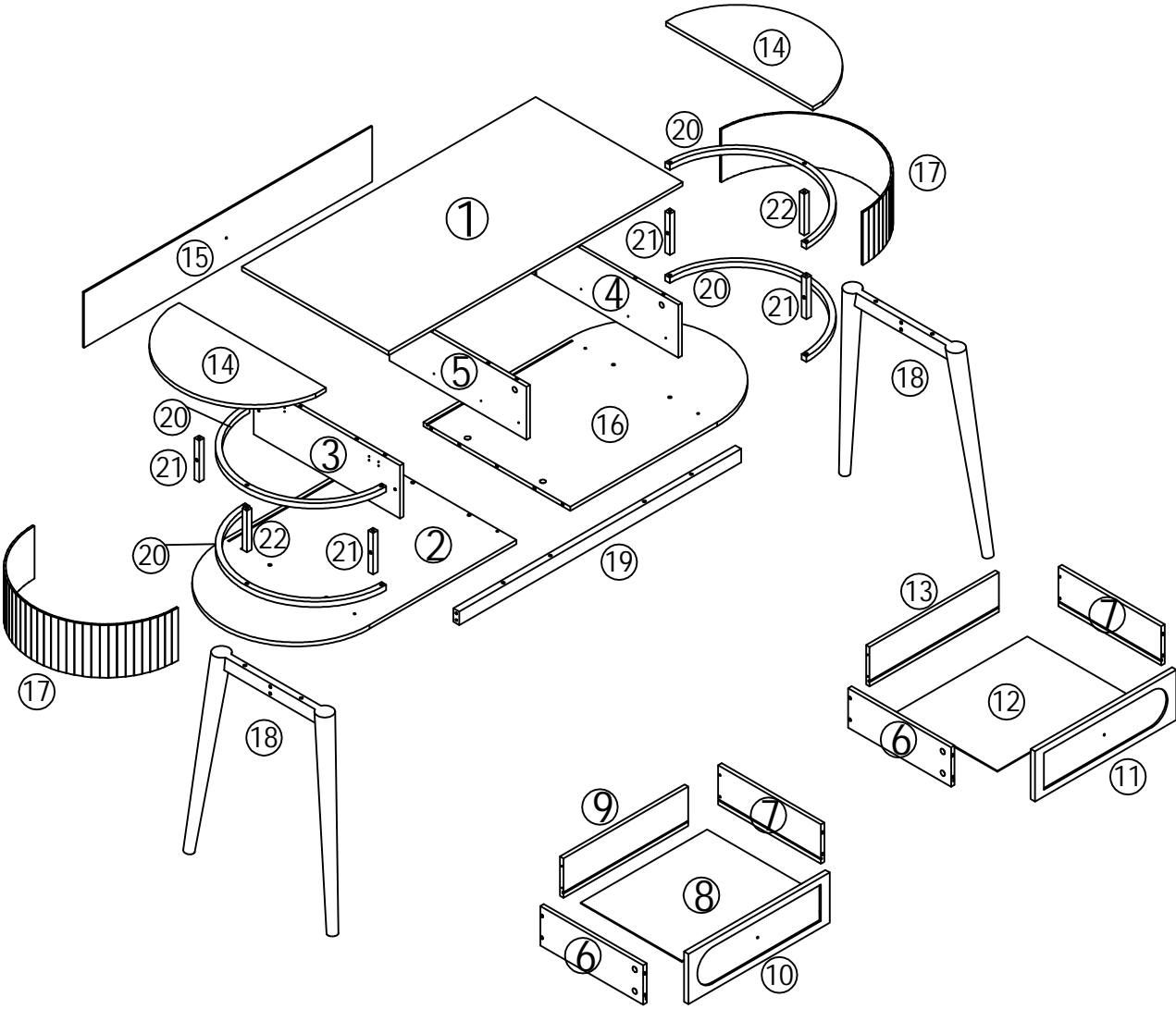
# The Accessoriess

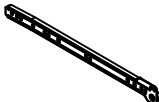

# Step 1

CL	x 2	CR	x 2	H	x12
					

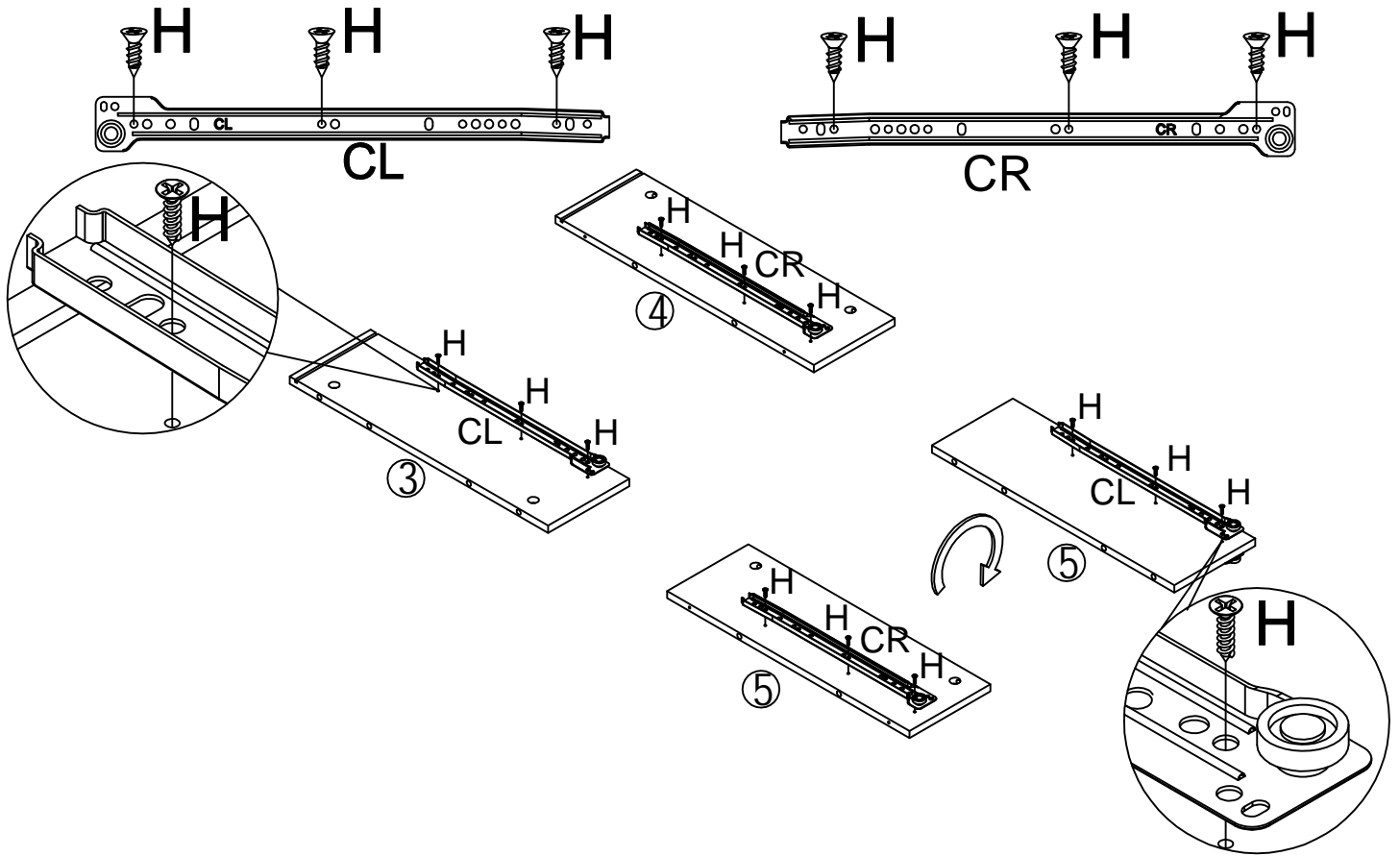

# Step 2

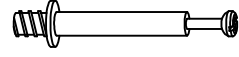
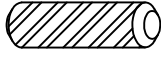
A	x 6	C	x 6
			

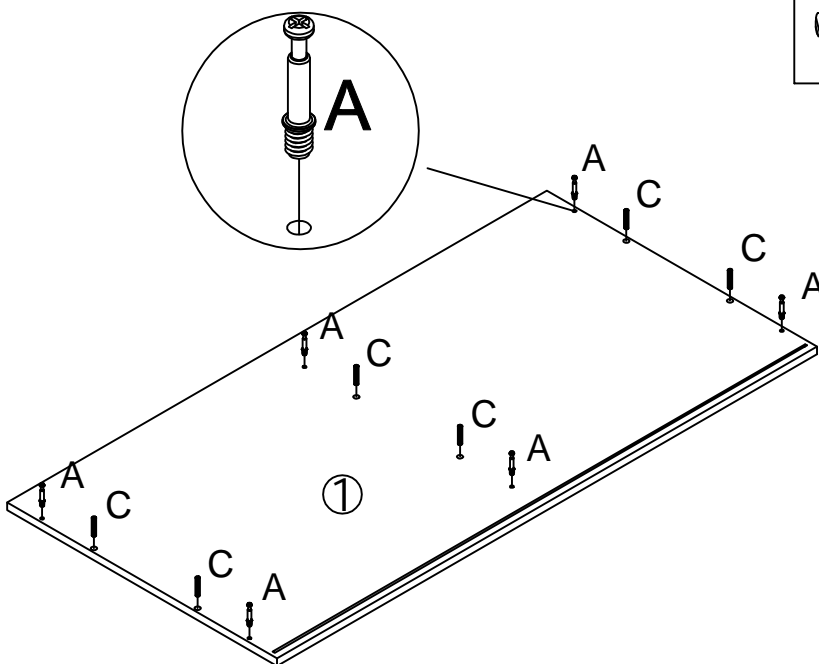

# Step 3

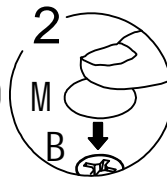
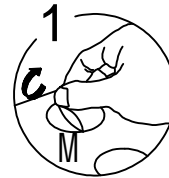
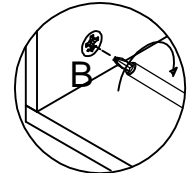
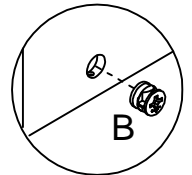
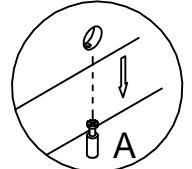
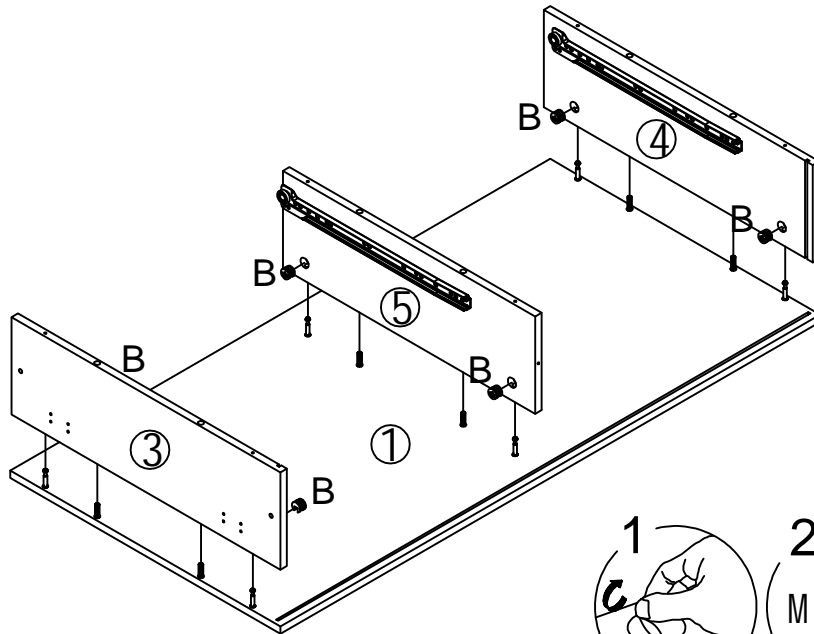
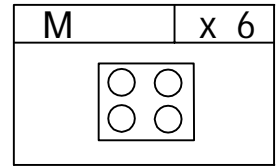
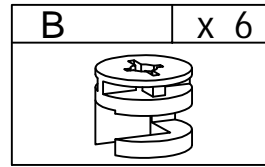

# Step 4

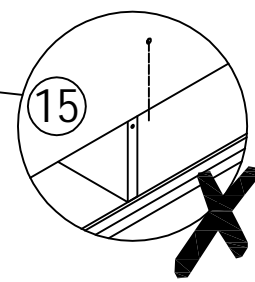
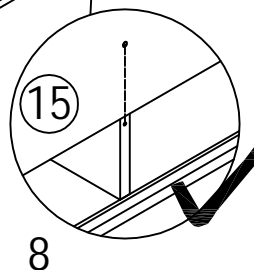
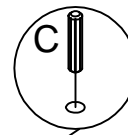
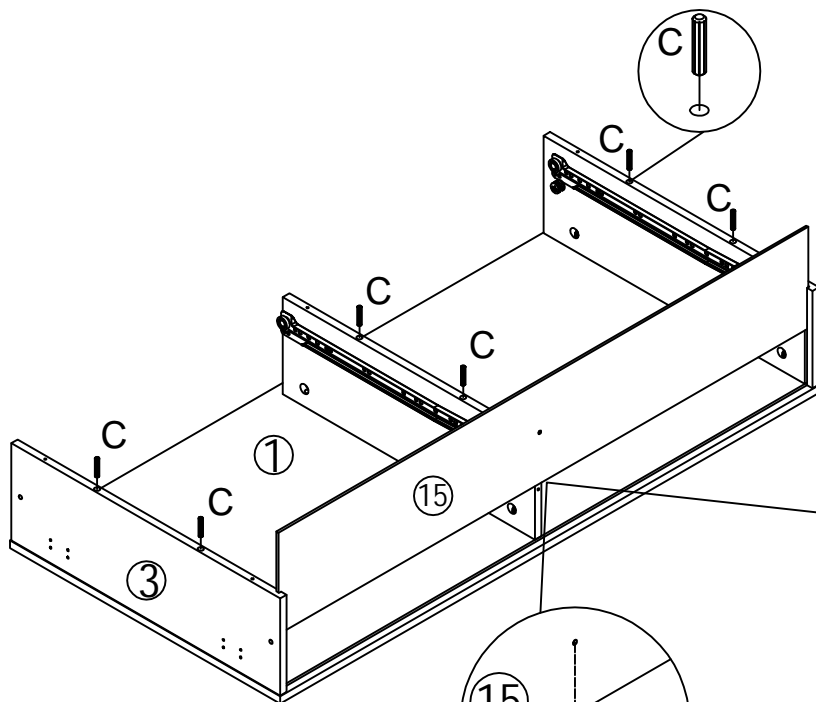
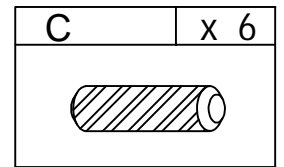

8

# Step 5

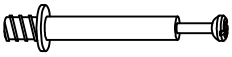
A	x 2
	

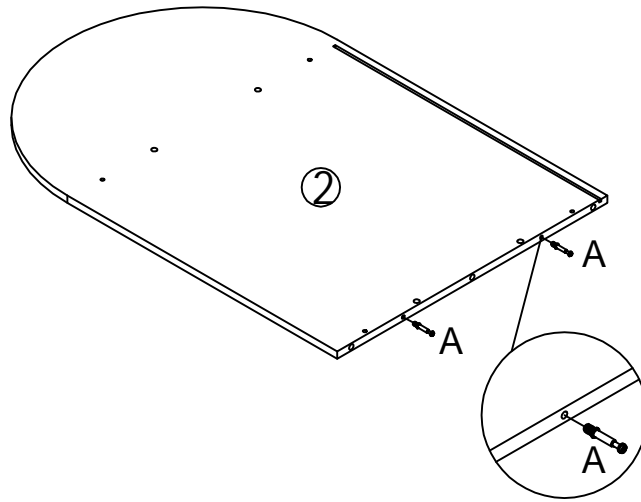

# Step 6

B	x 2
	

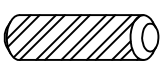
C	x 3
	

M	x 2
	

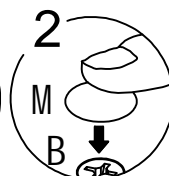
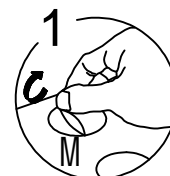
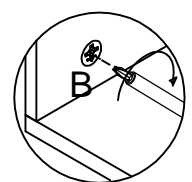
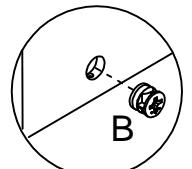
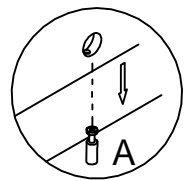
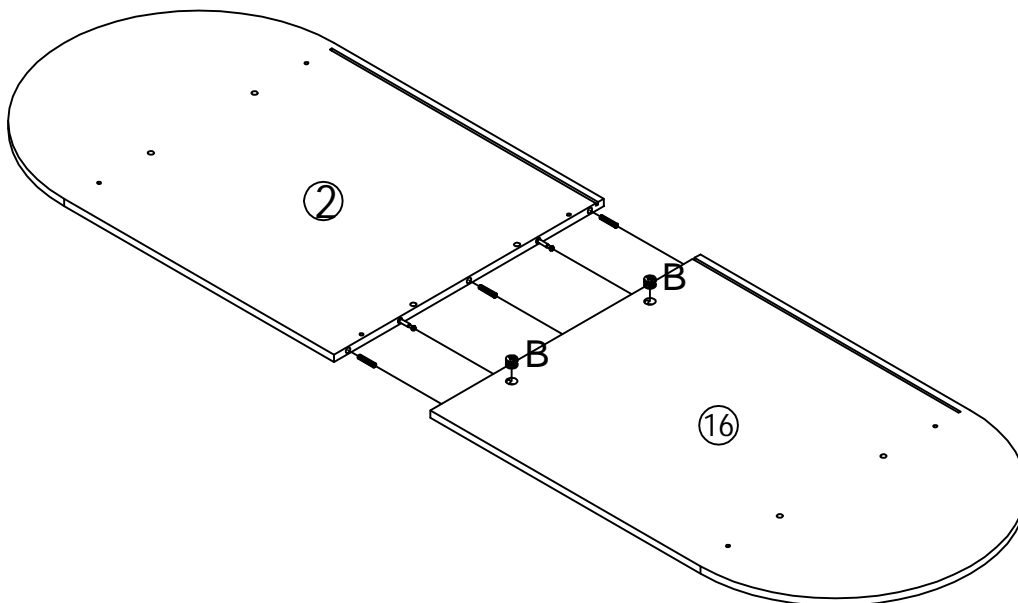

# Step 7

Please have multiple people install this step carefully to avoid the breakage of Board No. 2 and Board No. 16.

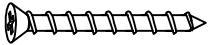
D	x 7
	

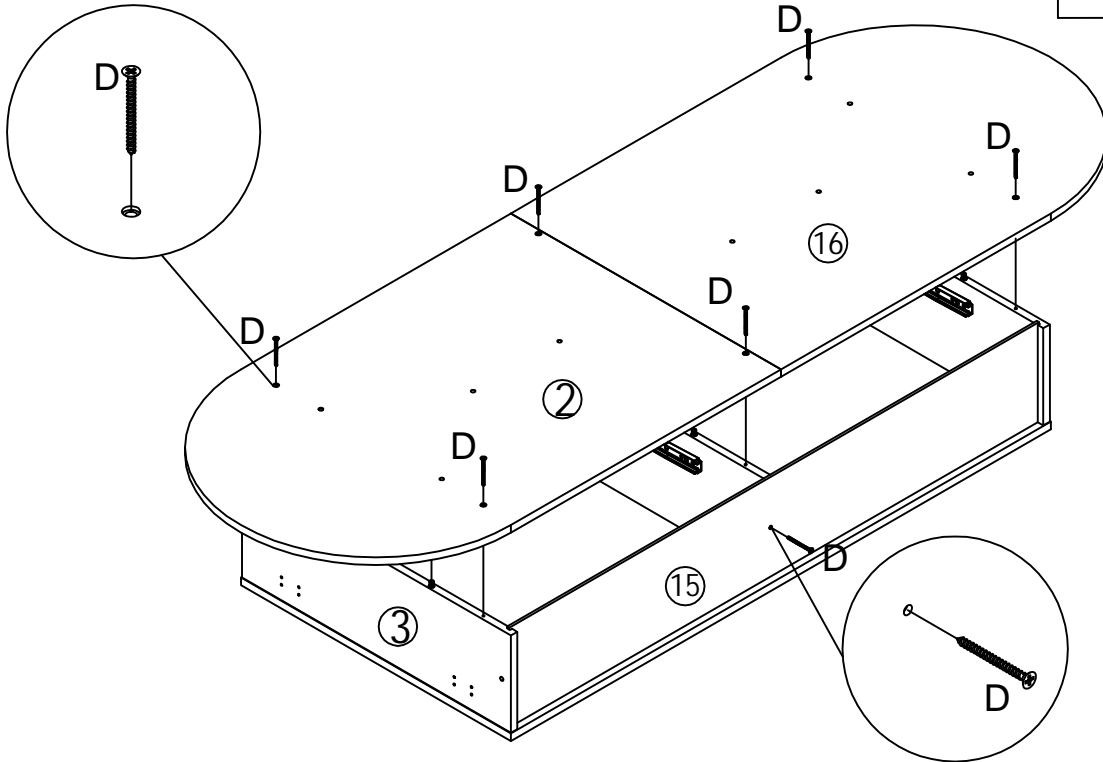

# Step 8

O	x 1
	

P	x 4
	

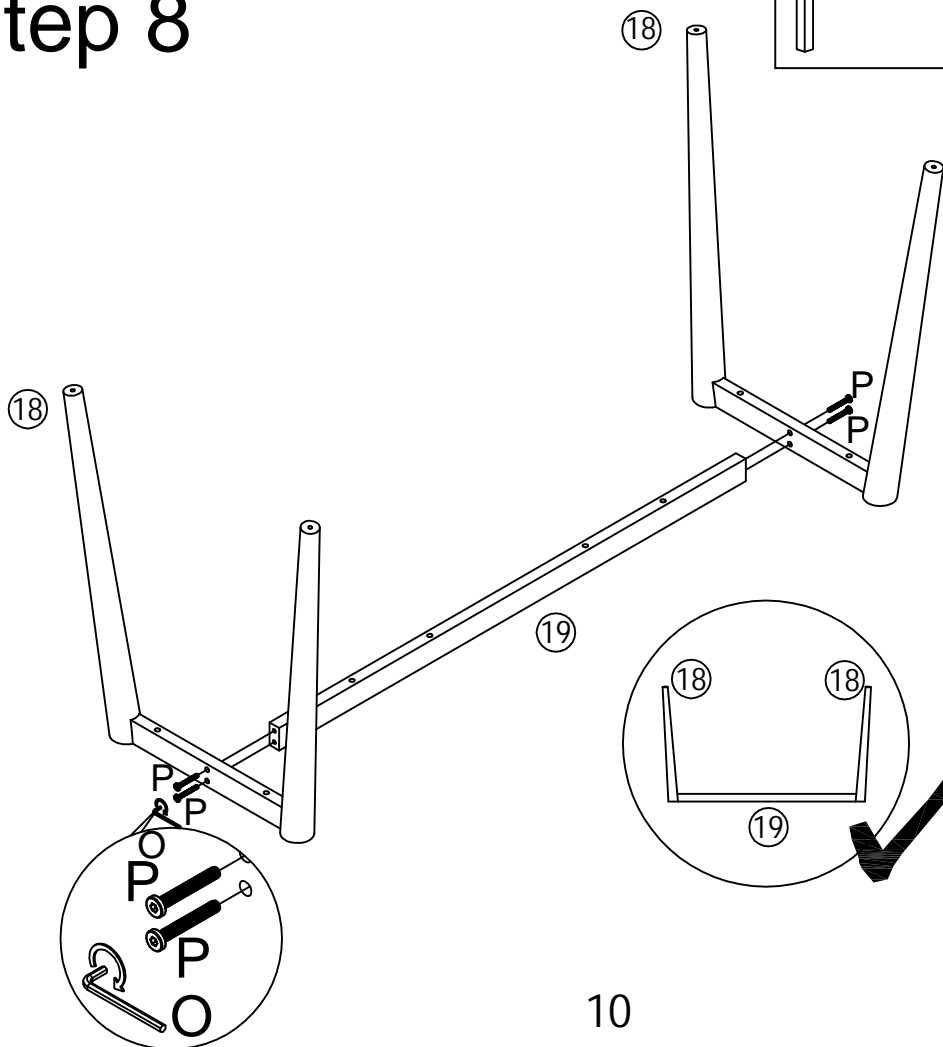

Please pay attention to the direction of number 18.

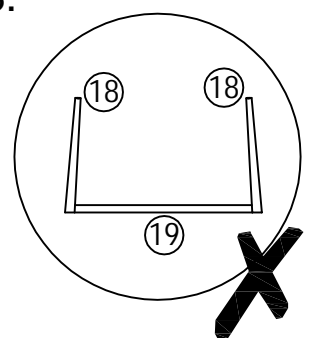
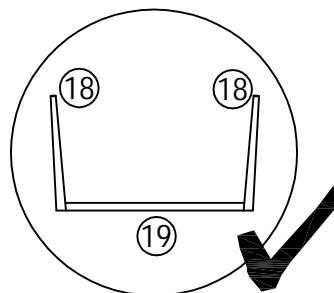

# Step 9

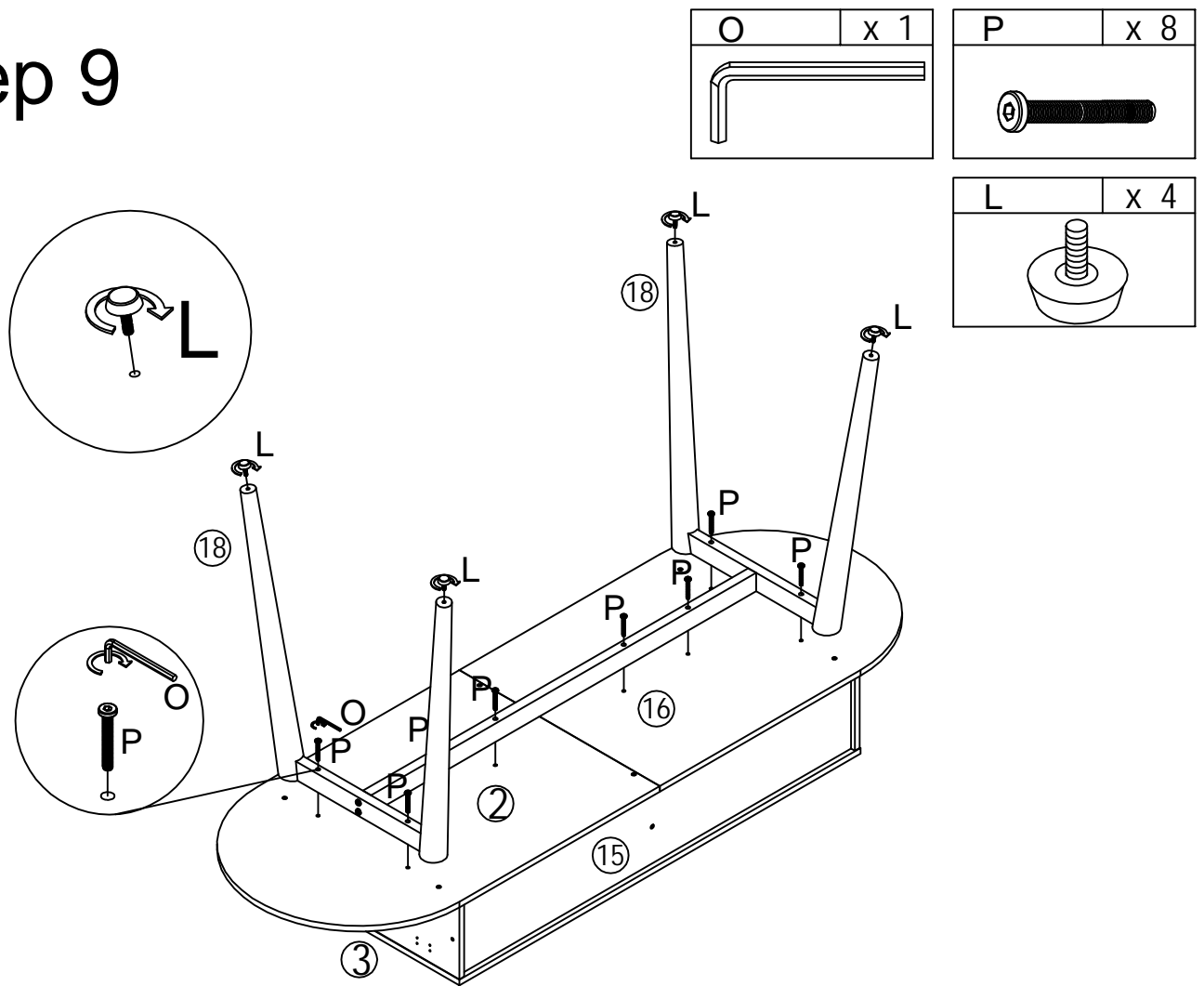

# Step 10

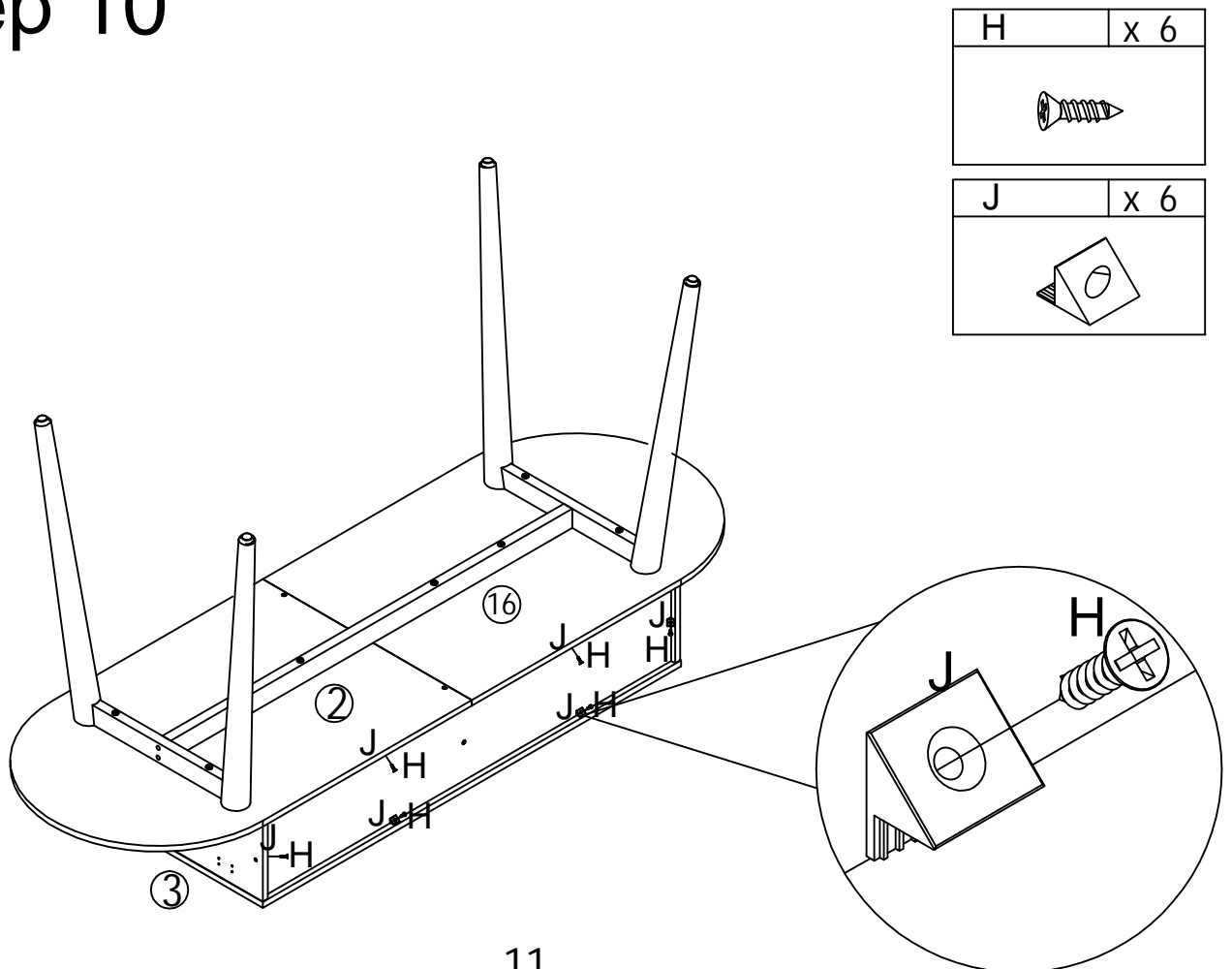

# Step 11

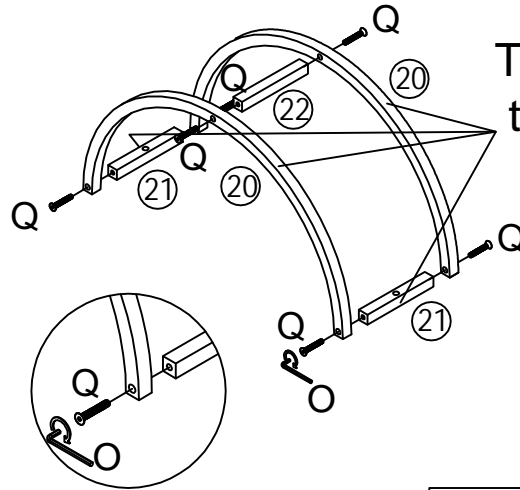
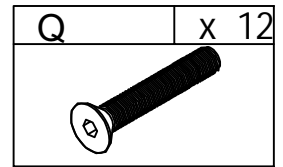
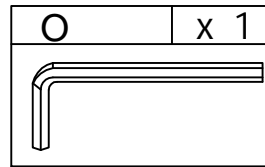

There are Velcro on these four sides.

x 2

# Step 12

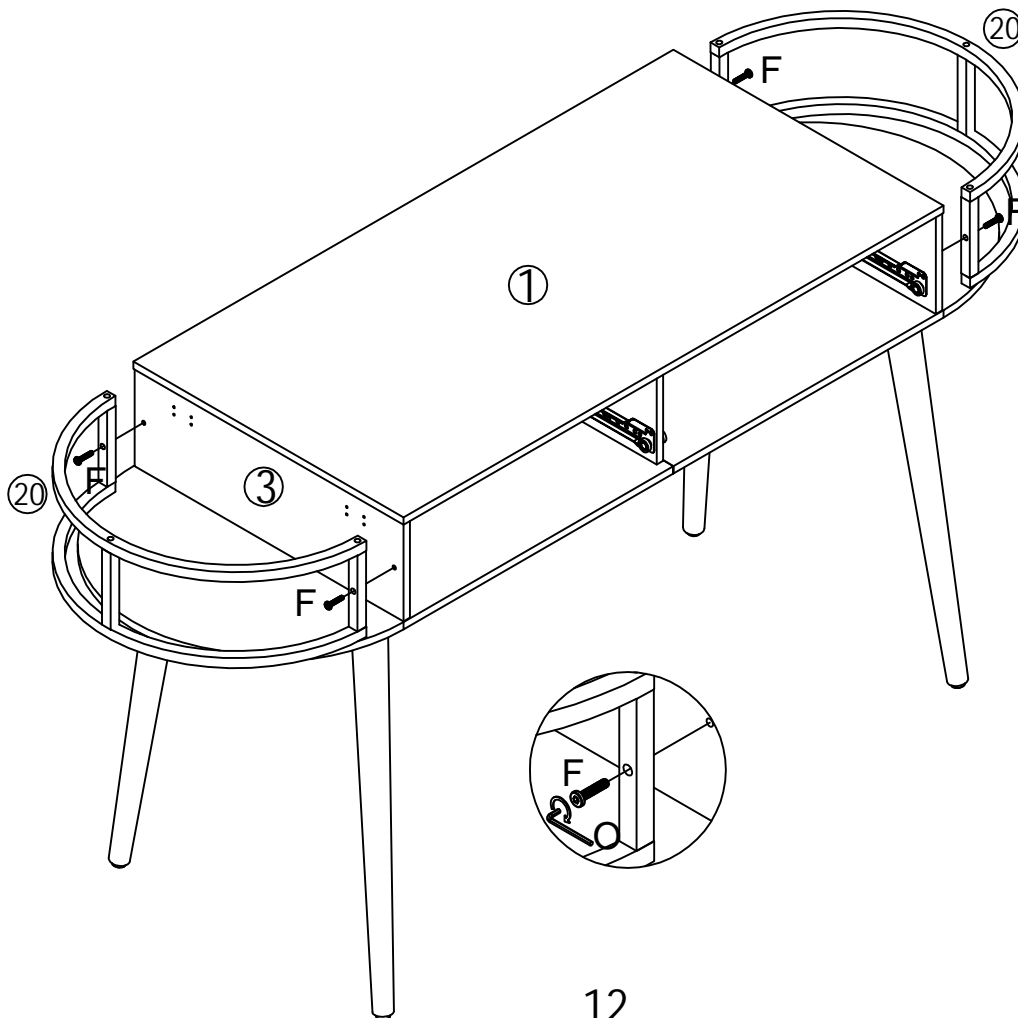
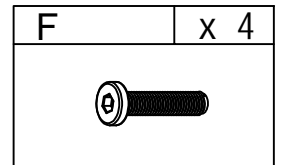
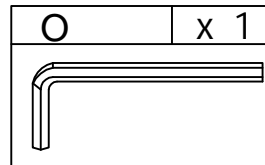

# Step 13

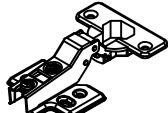
R	x 4
	

H	x 8
	

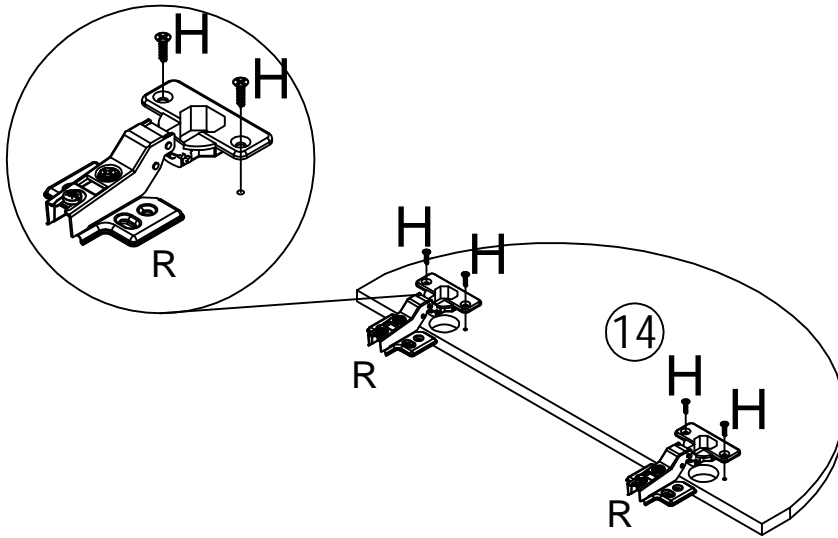

x 2

# Step 14

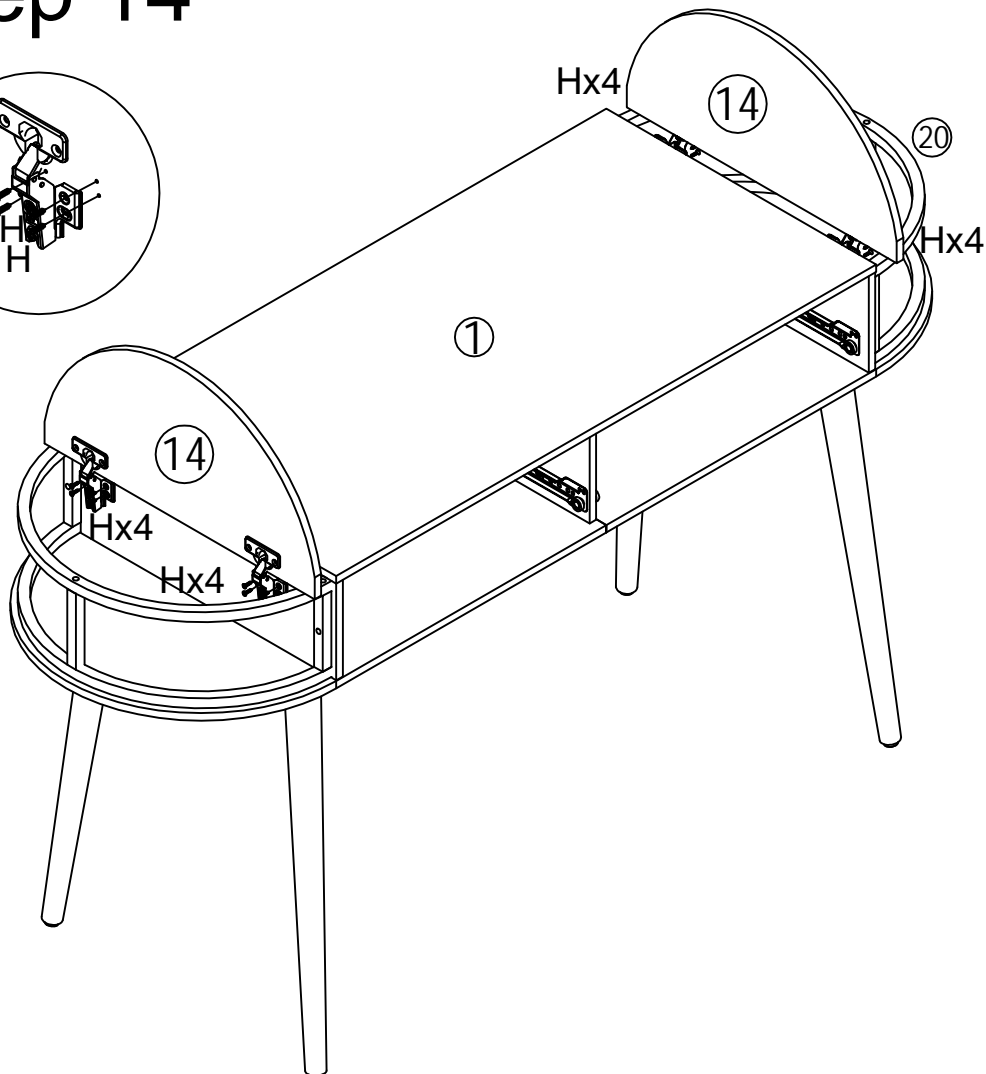
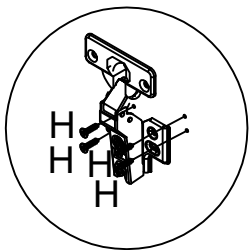

H	x 16
	

# Step 14-1

How do I get the two doors to align flat by adjusting the hinges?

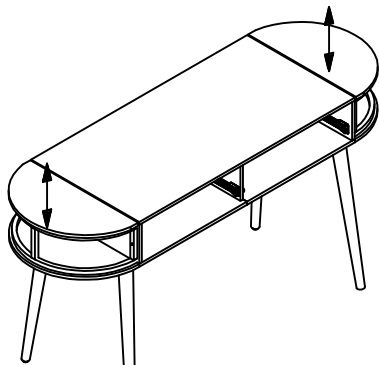

1. The screws can be loosened to adjust the uneven problem under the table top.

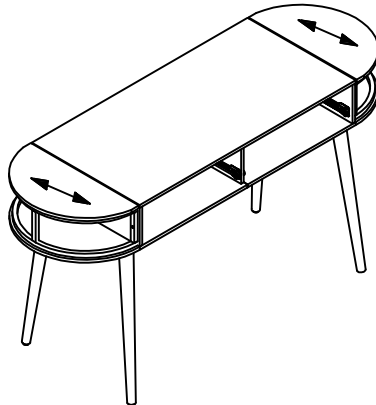

2. Adjust the screws shown in Fig. 2 and pull the door back and forth so that it can be opened smoothly.

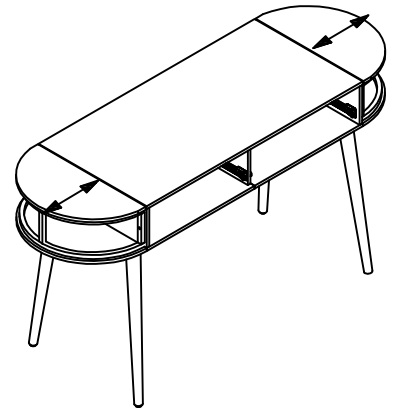

3. Adjust the screws shown in Figure 3 to adjust the door left and right to the right position.

# Step 15

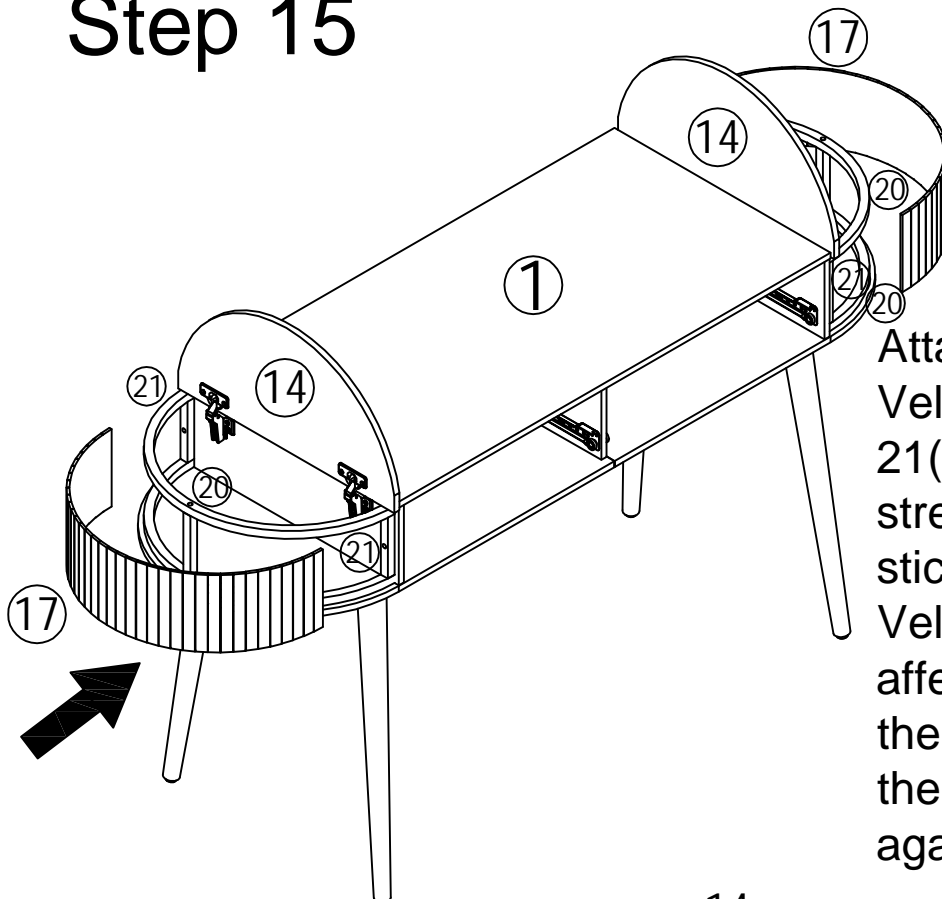

Attach Board 17 neatly to the Velcro of iron 20 and 21 (Attention: Please fully stretch part 4 and then stick it tightly along the Velcro to avoid gaps that affect the appearance. If there are obvious gaps, tear them off and stick them again.)

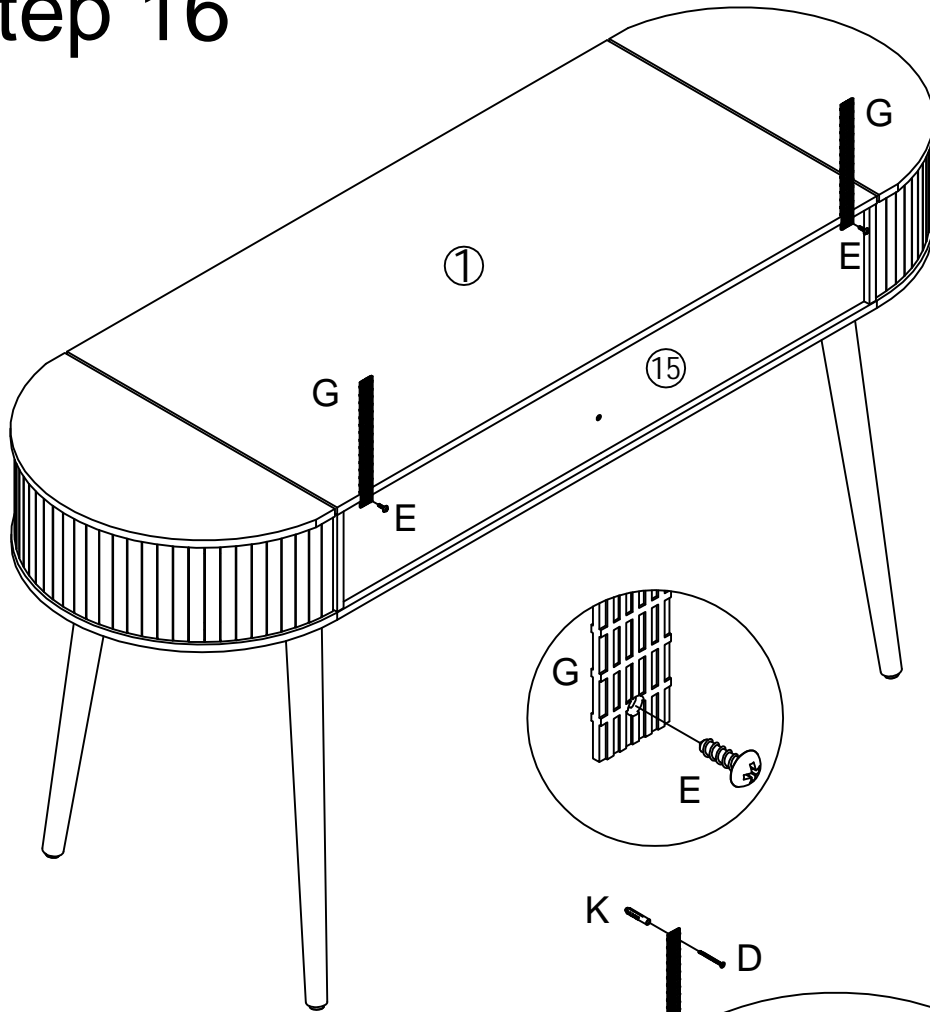

# Step 16

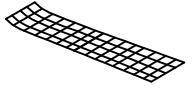

E	x 2
	
G	x 2
	

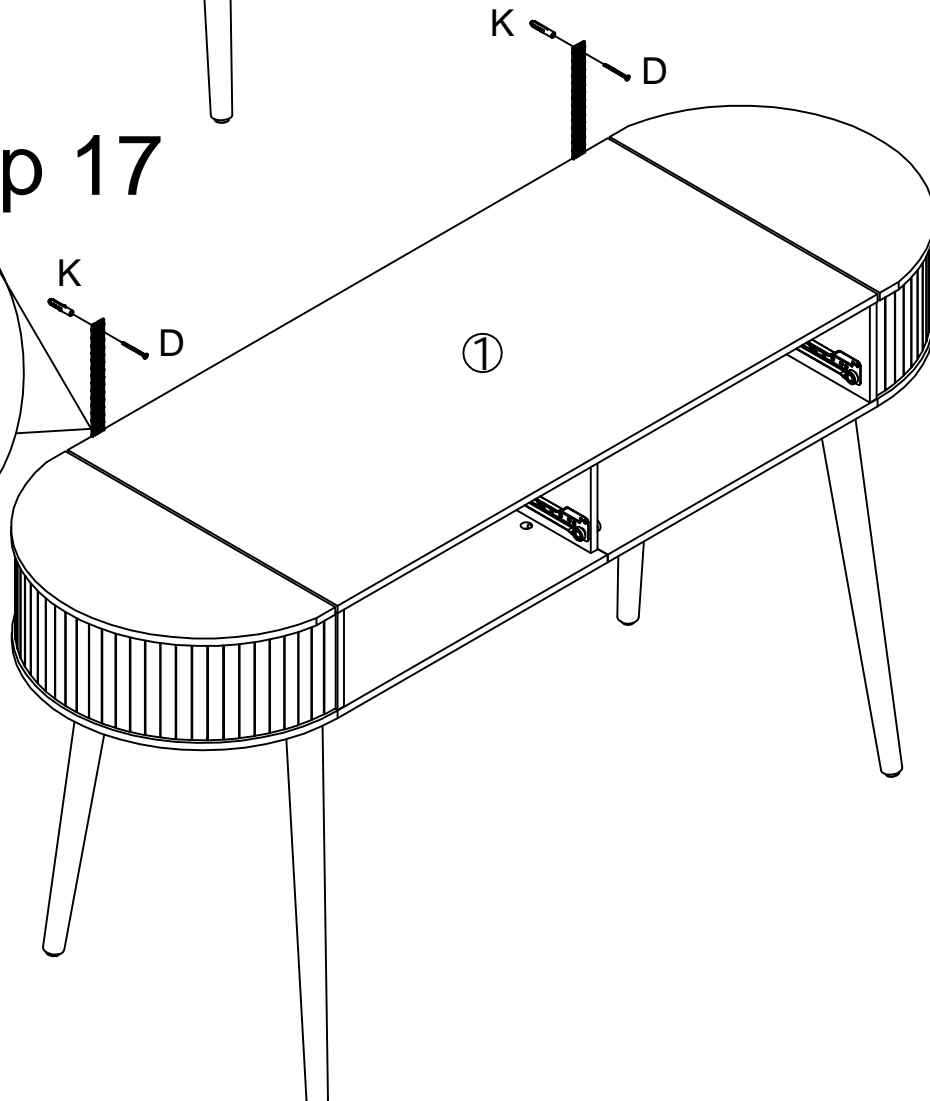
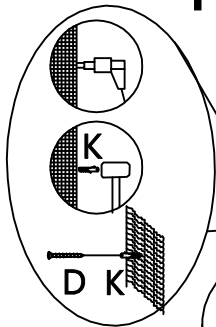
# Step 17

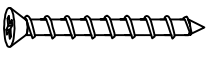

D	x 2
	
K	x 2
	

# Step 18

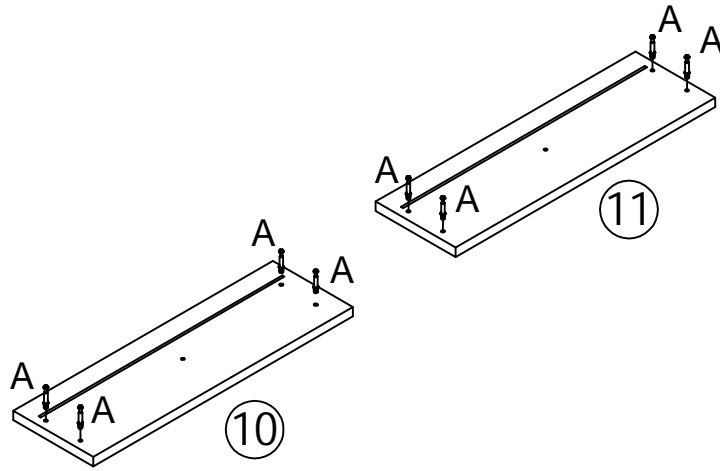
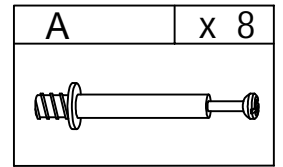

# Step 19

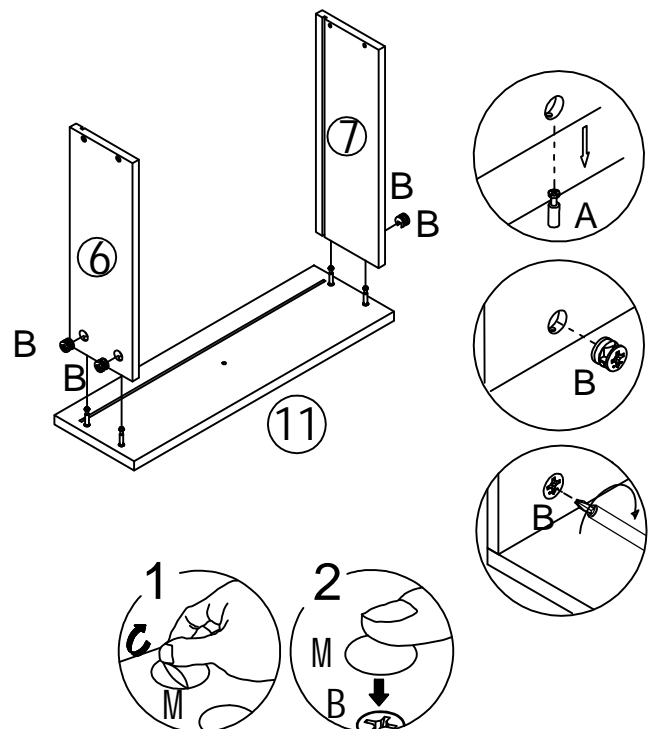
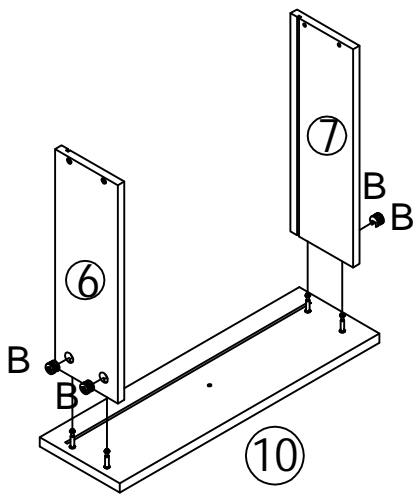
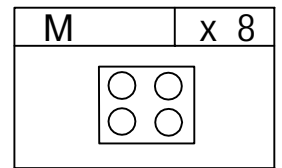
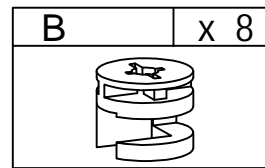

# Step 20

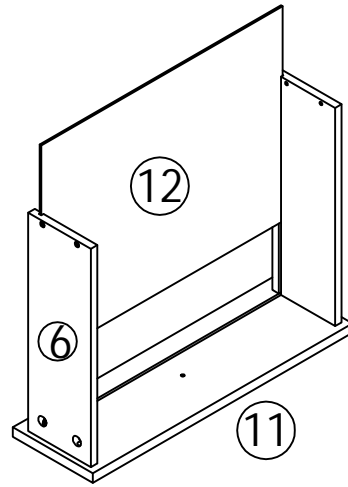
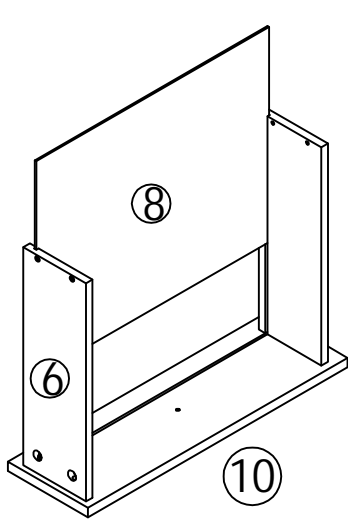

# Step 21

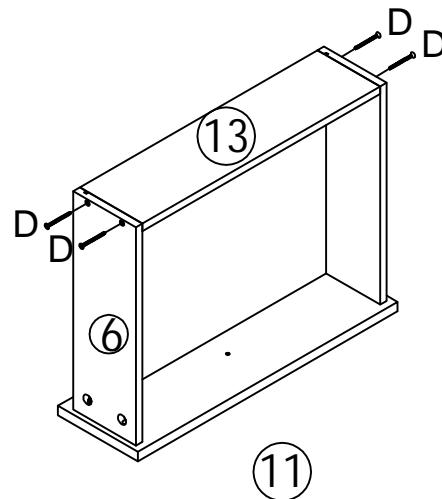
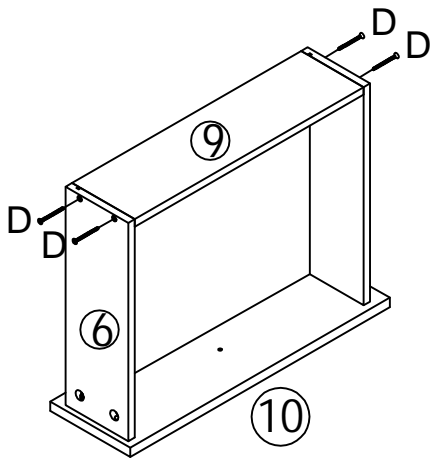
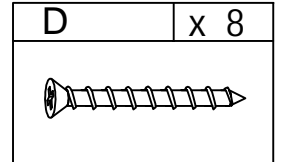

# Step 22

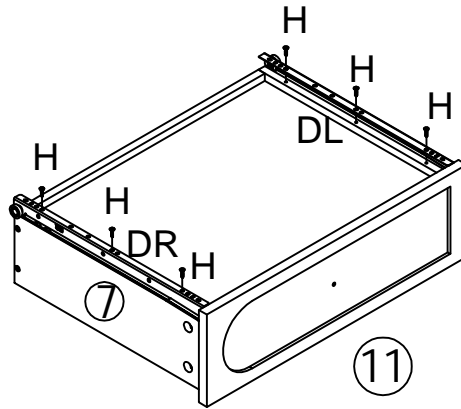
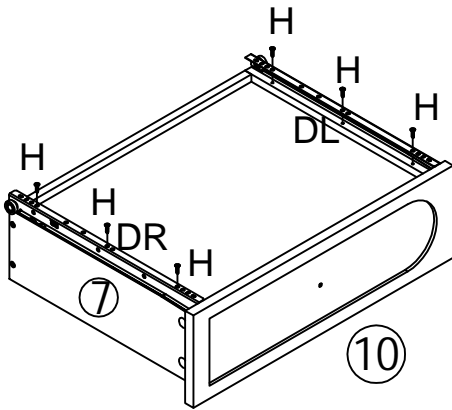
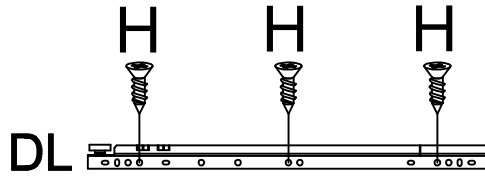
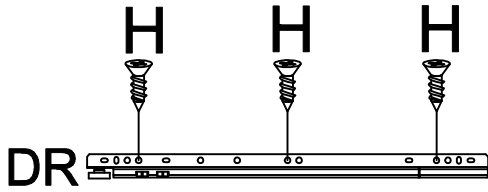
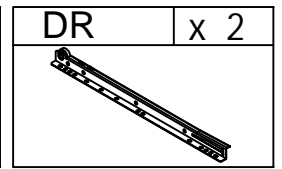
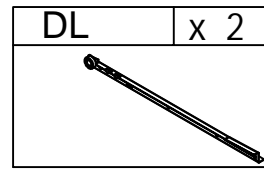
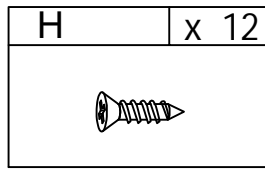

# Step 23

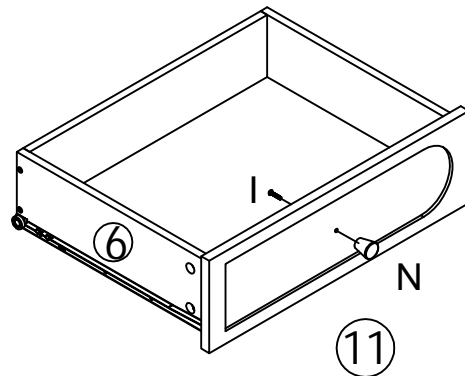
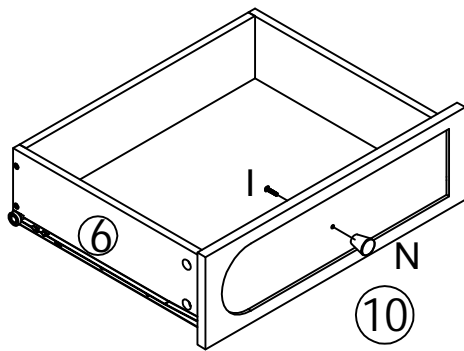
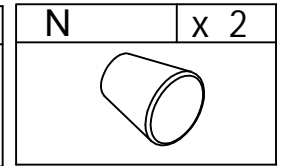
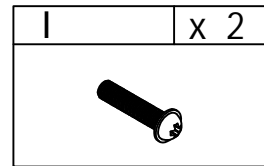

# Step 24

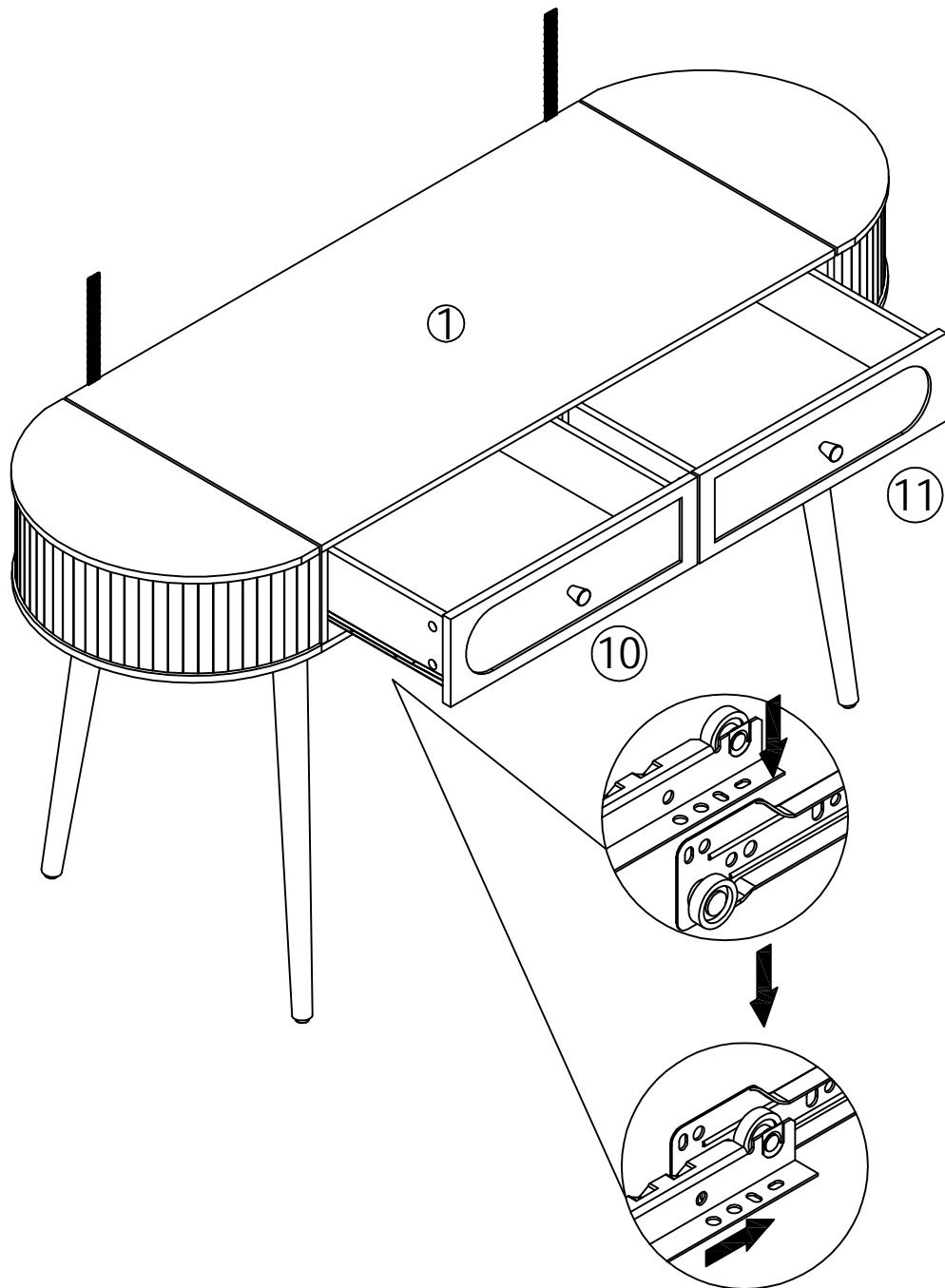

# Step 25

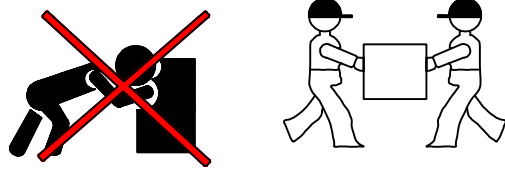
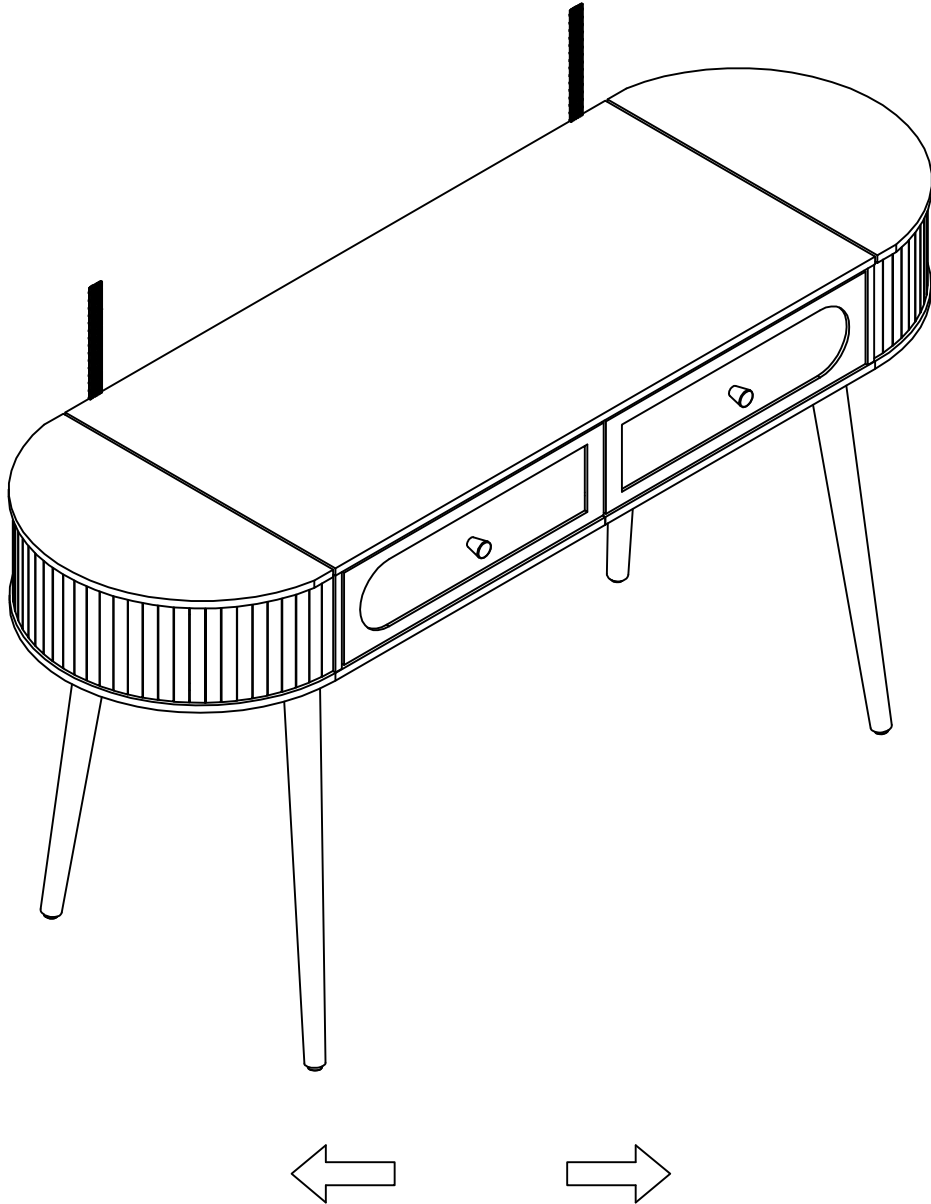

Two people work together to move the table.  
Make sure you lift it off the ground.  
Don't push and pull.