

Assembly Instructions

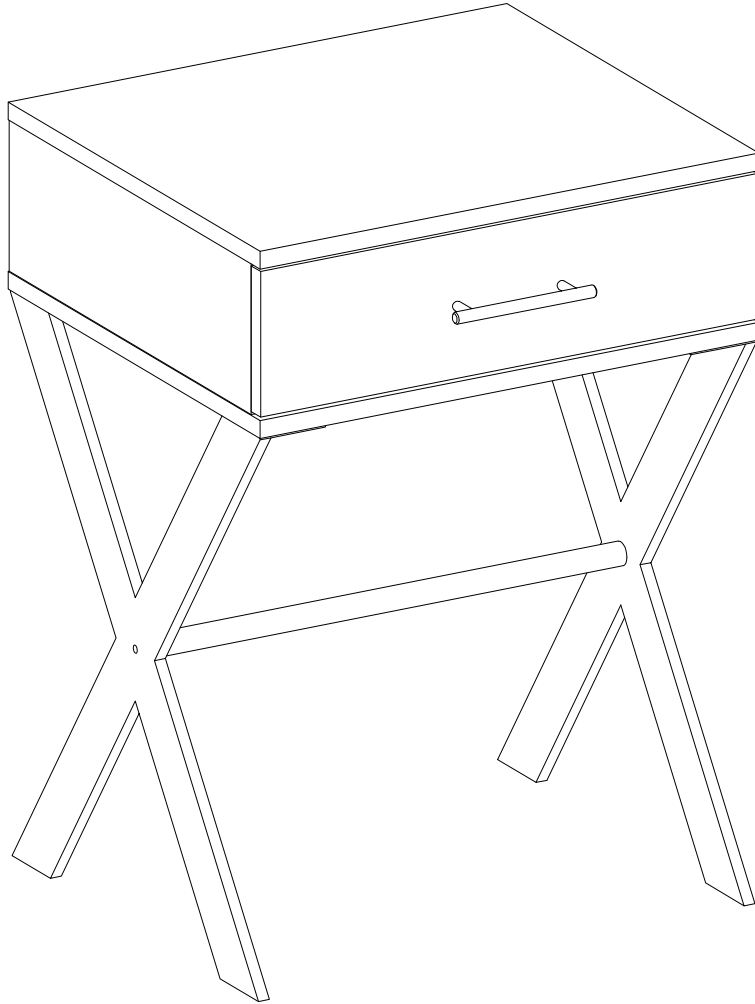

General Assembly Guidelines

- I. Ensure that all parts and hardware are available before beginning assembly.
- II. Follow each step carefully to ensure the proper assembly of this product.
- III. Two people are recommended for ease in the assembly of this product.
- IV. The three main types of hardware used to assemble this product are : wood dowels , screws and bolts.
- V. The provided glue is to secure wood dowels in place . When first inserting dowels , locate the appropriate hole for the dowel , place a small amount of glue in the hole and insert the dowel . Wipe away excess glue immediately.

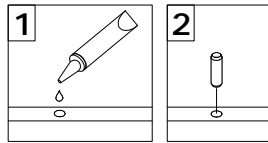

In future assembly steps when dowels are necessary to attach assembly parts together , place a small amount of glue on the end of the dowel before attaching parts together . Wipe away excess glue immediately.

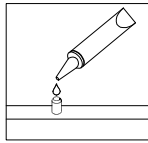

- VI. A Phillips head screwdriver is required for the assembly of this product .

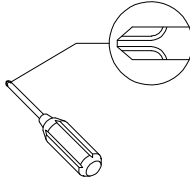



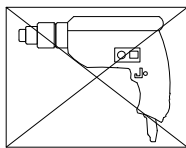



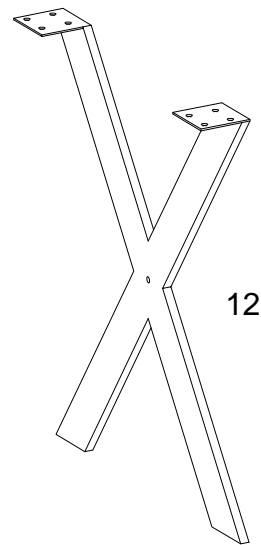
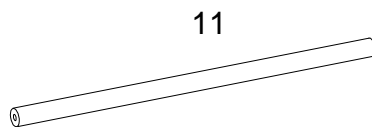
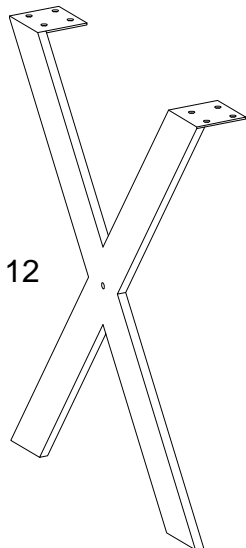
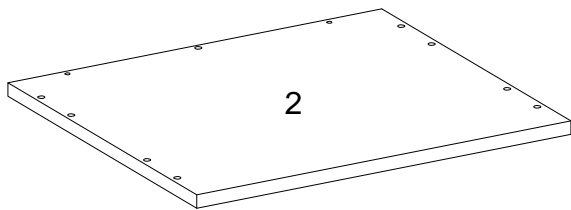
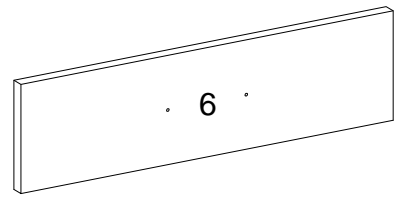
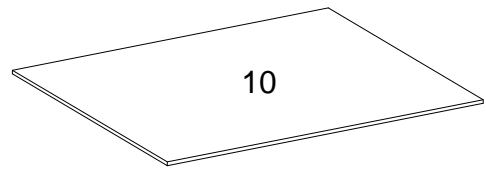
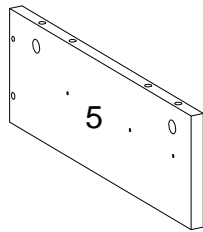
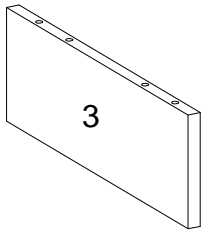
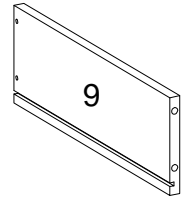
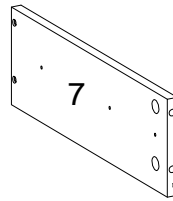
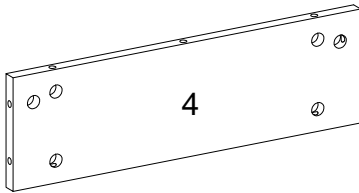
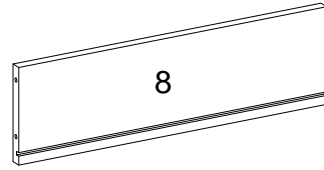
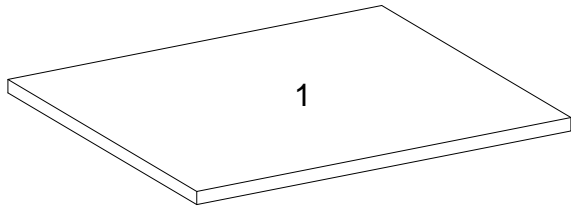





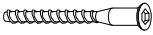

- VII. Power tools should not be used to assemble this product .



Parts List

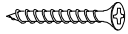

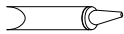
Hardware List

A		Ø8x30mm	Wooden dowel	8	pcs
B		Ø6x35mm	Cam bolt	14	pcs
C		Ø15x11mm	Cam lock	4	pcs
D		Ø15x9mm	Cam lock	10	pcs
E		Ø30mm	Sticker	14	pcs
F		Ø6x50mm	Screw	4	pcs
G		Ø6x12mm	Bolt	16	pcs
H		Ø6x25mm	Bolt	2	pcs
J		M 4	Hex key	1	pc
K			Handle	1	pc
L		Ø4x22mm	Handle Bolt	2	pcs
M		Ø4x32mm	Screw	4	pcs
N		Ø3x12mm	Screw	12	pcs
P		Ø6x30mm	Wooden dowel	4	pcs
Q			Glue tube	1	pc
R			Drawer slider	1	set

* Note: This piece comes preassembled for shipping purposes and must be disassembled to complete the desk assembly.

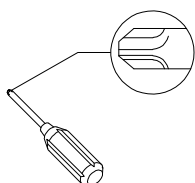

Philips head screwdriver required for assembly
(not included)

*The hardware quantities listed above are required for proper assembly.
Some extra hardware may also have been included.*

Step 1

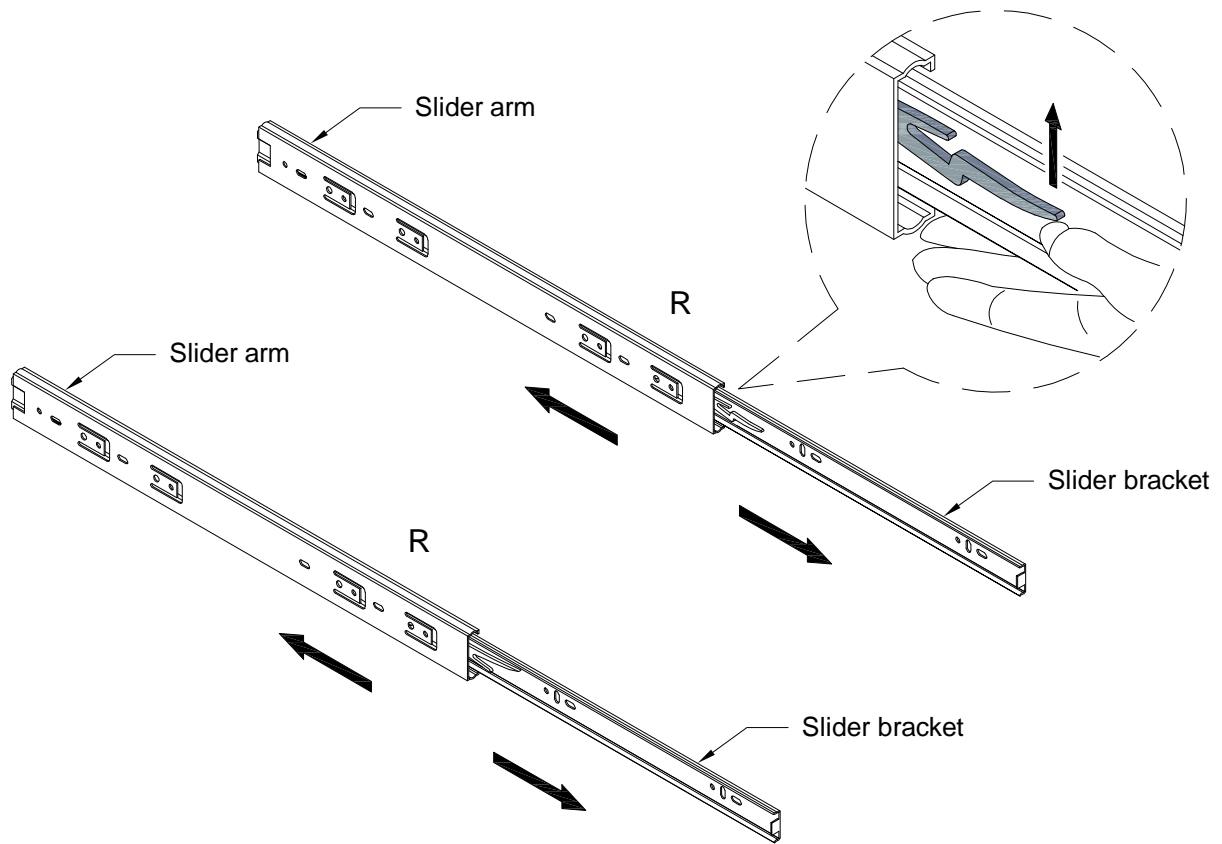

Pick up the slider arm (R) and separate the slide Runner for the following Steps. Extend the Slide .Runner all the way forward,press the plastic release lever of the alider arm up and pull the Slide Runner Complete out .

Step 2

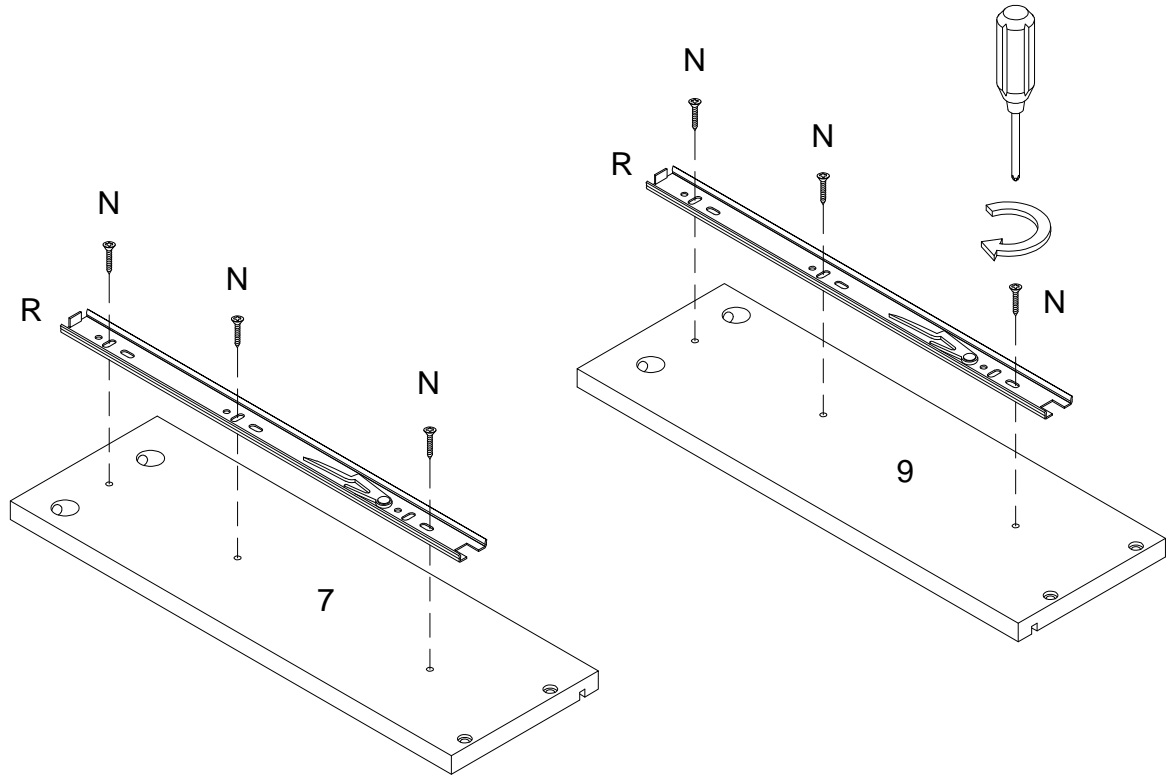

Using Screw (N) attach slider (R) to parts (7,9) with Philips head screwdriver as per diagram.

Step 3

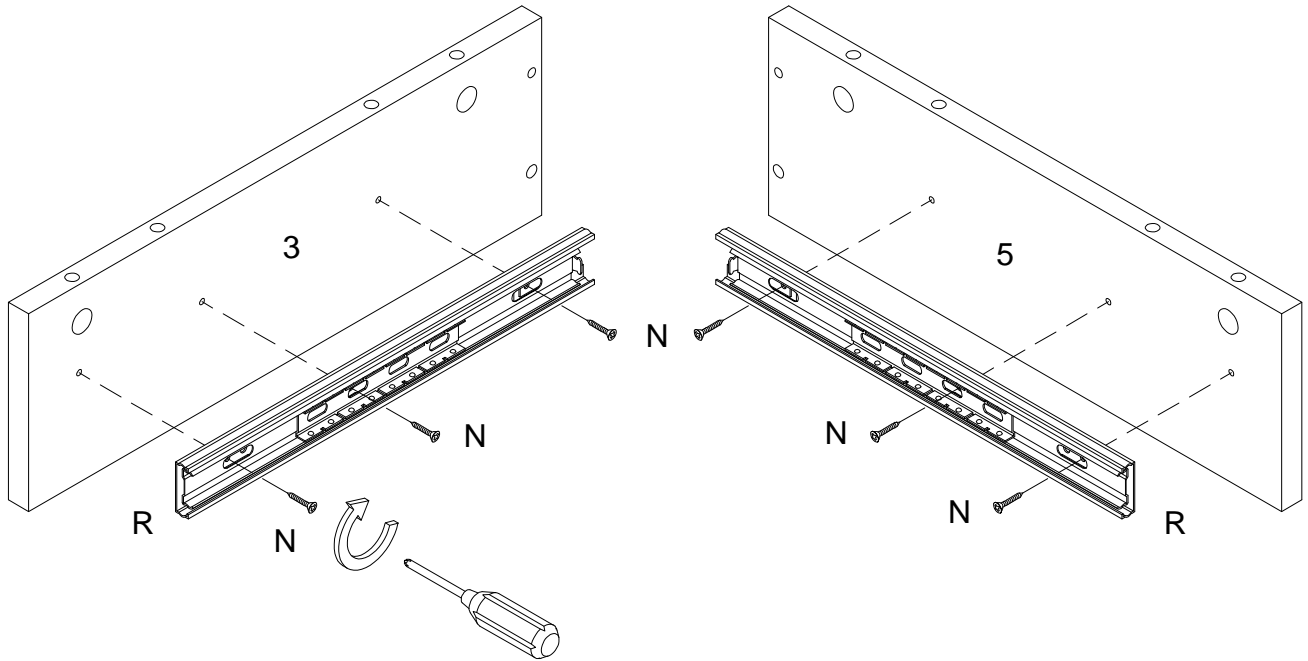

Using Screw (N) attach slider (R) to parts (3,5) with Philips head screwdriver as per diagram.

Step 4

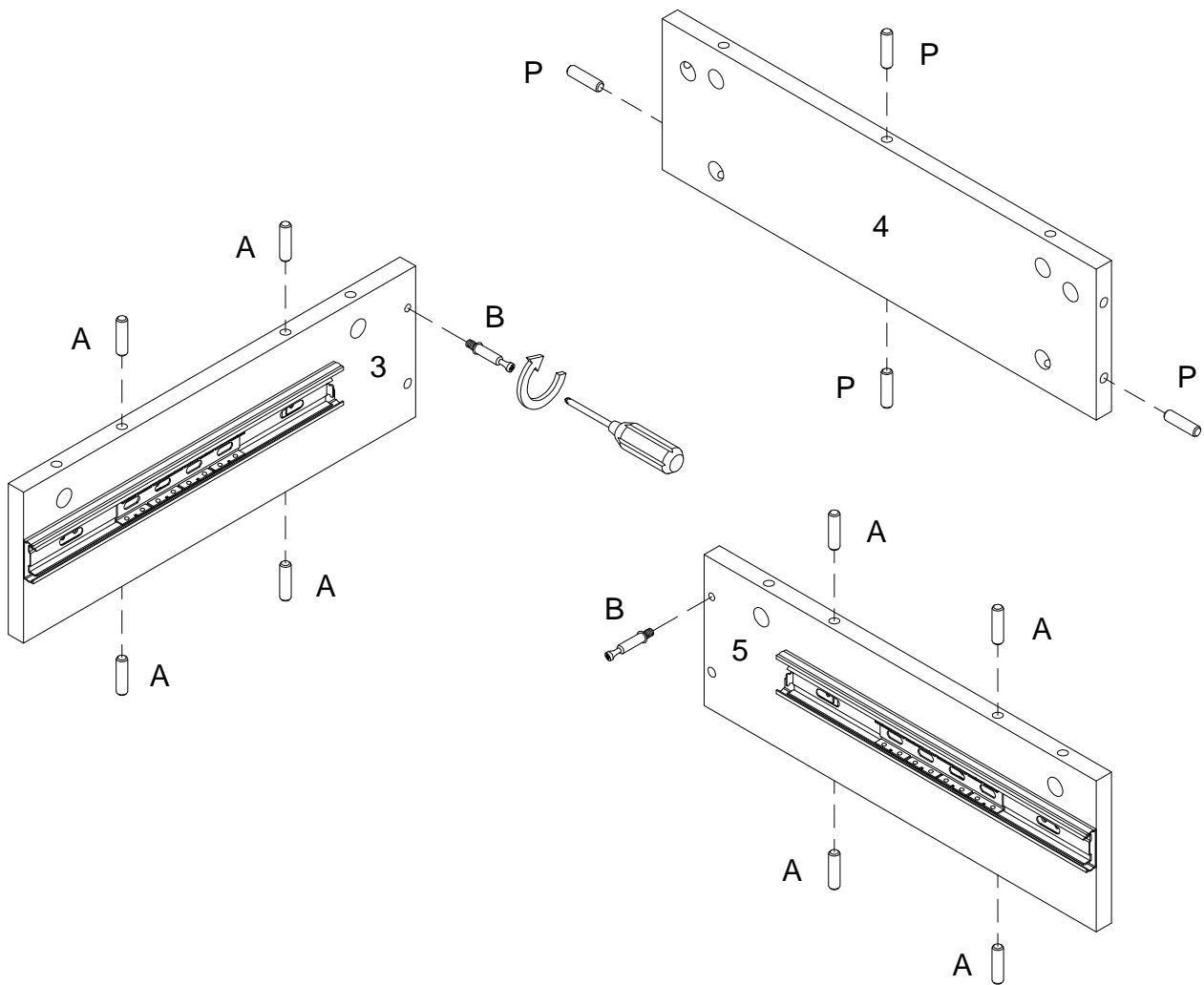

Insert wooden dowel (A) into parts (3,5) and wooden dowel (P) into part (4) , then secure Cam bolt (B) into part (3,5) with Philips head screwdriver as per diagram.

Step 5

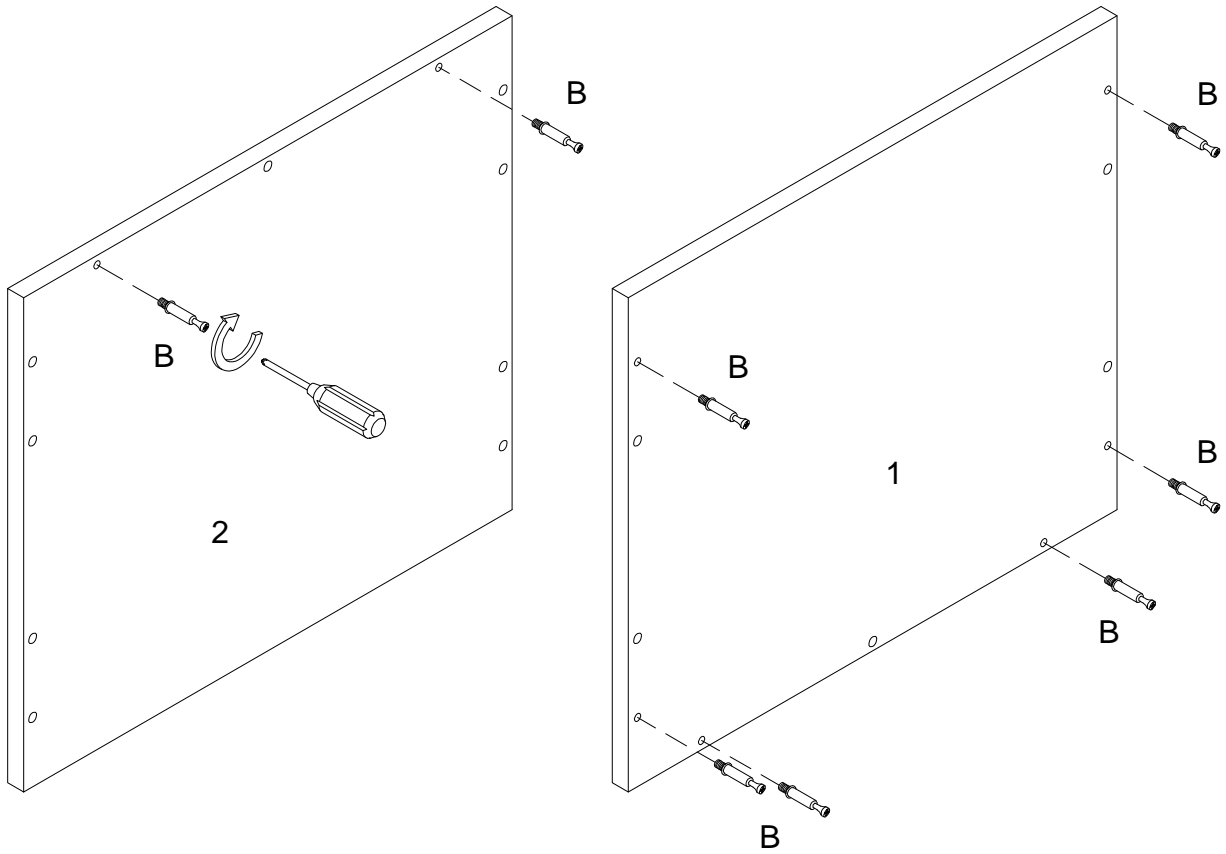

Secure cam bolt (B) into parts (1,2) with Philips head screwdriver as per diagram.

Step 6

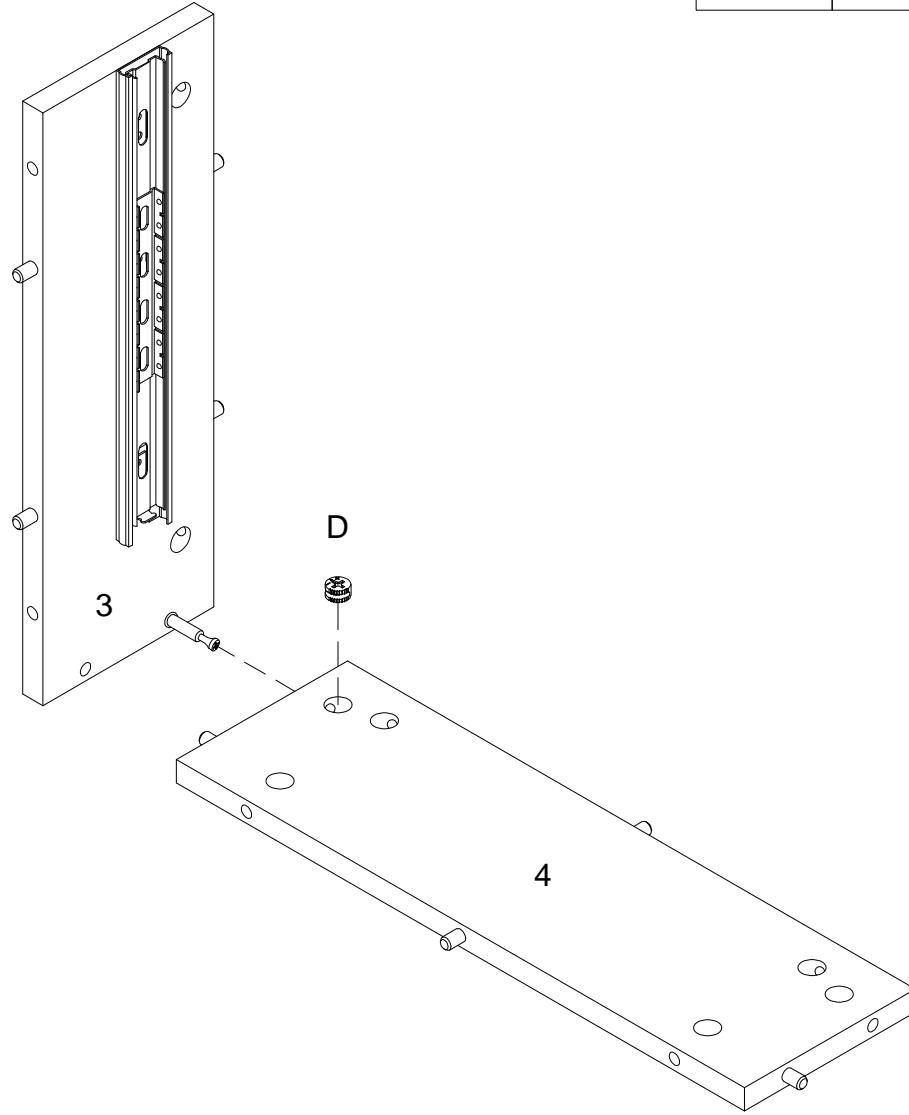
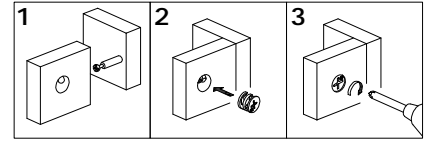

Using Cam lock(D) secure part (3) to part (4) with Philips head screwdriver as per diagram.

Step 7

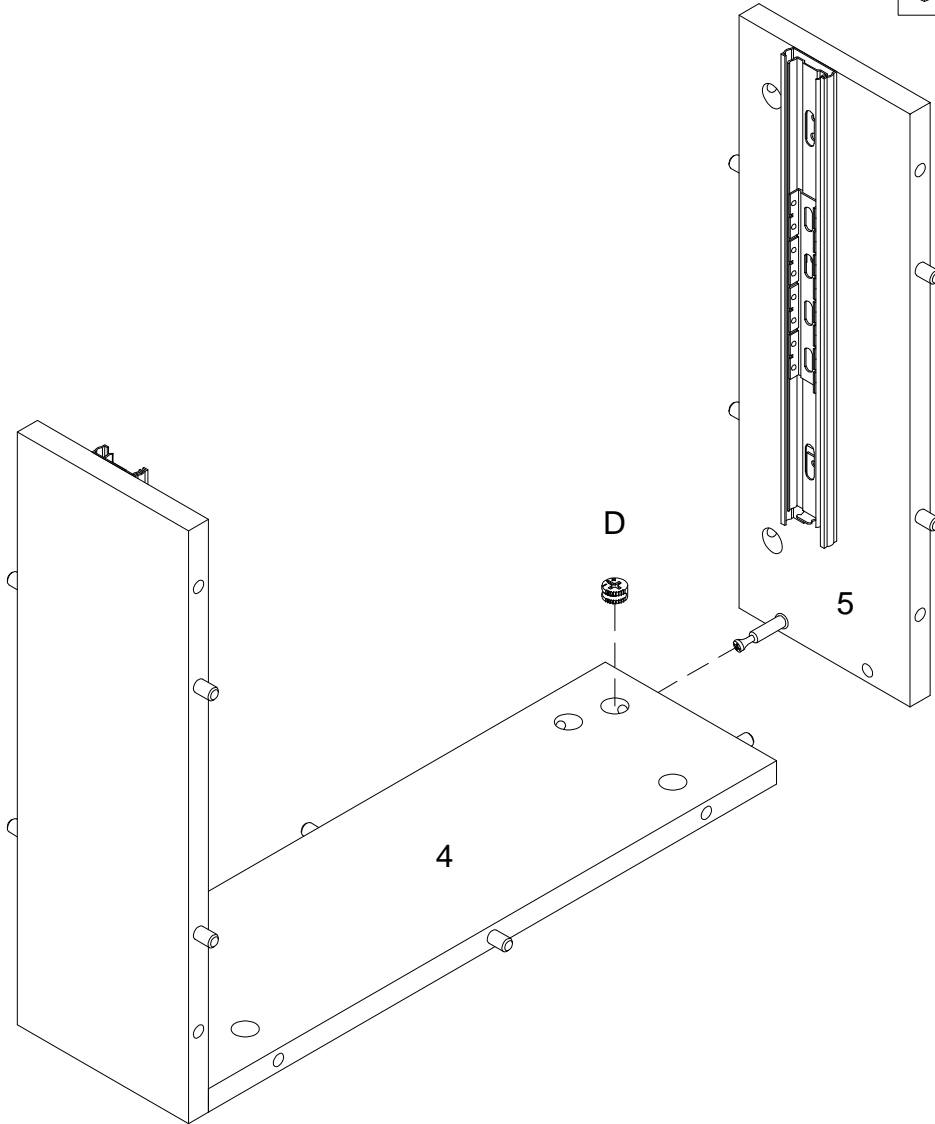
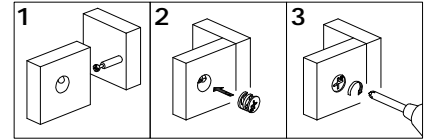

Using Cam lock(D) secure part (5) to part (4) with Philips head screwdriver as per diagram.

Step 9

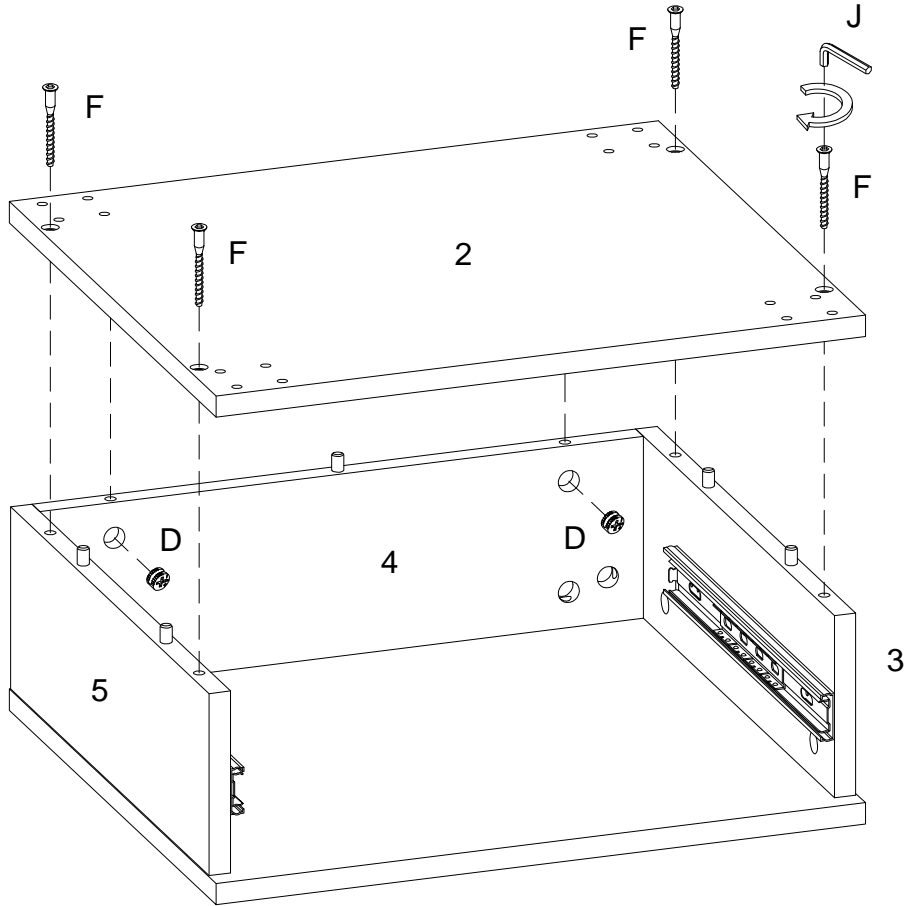
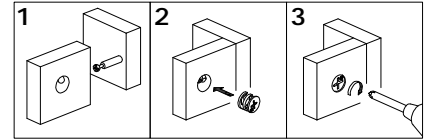

Using Screw (F) attach part (2) into parts (3,4,5) with Hex key (J) ,then using Cam lock (D) secure part (2) to part (4) with Philips head screwdriver as per diagram.

Step 10

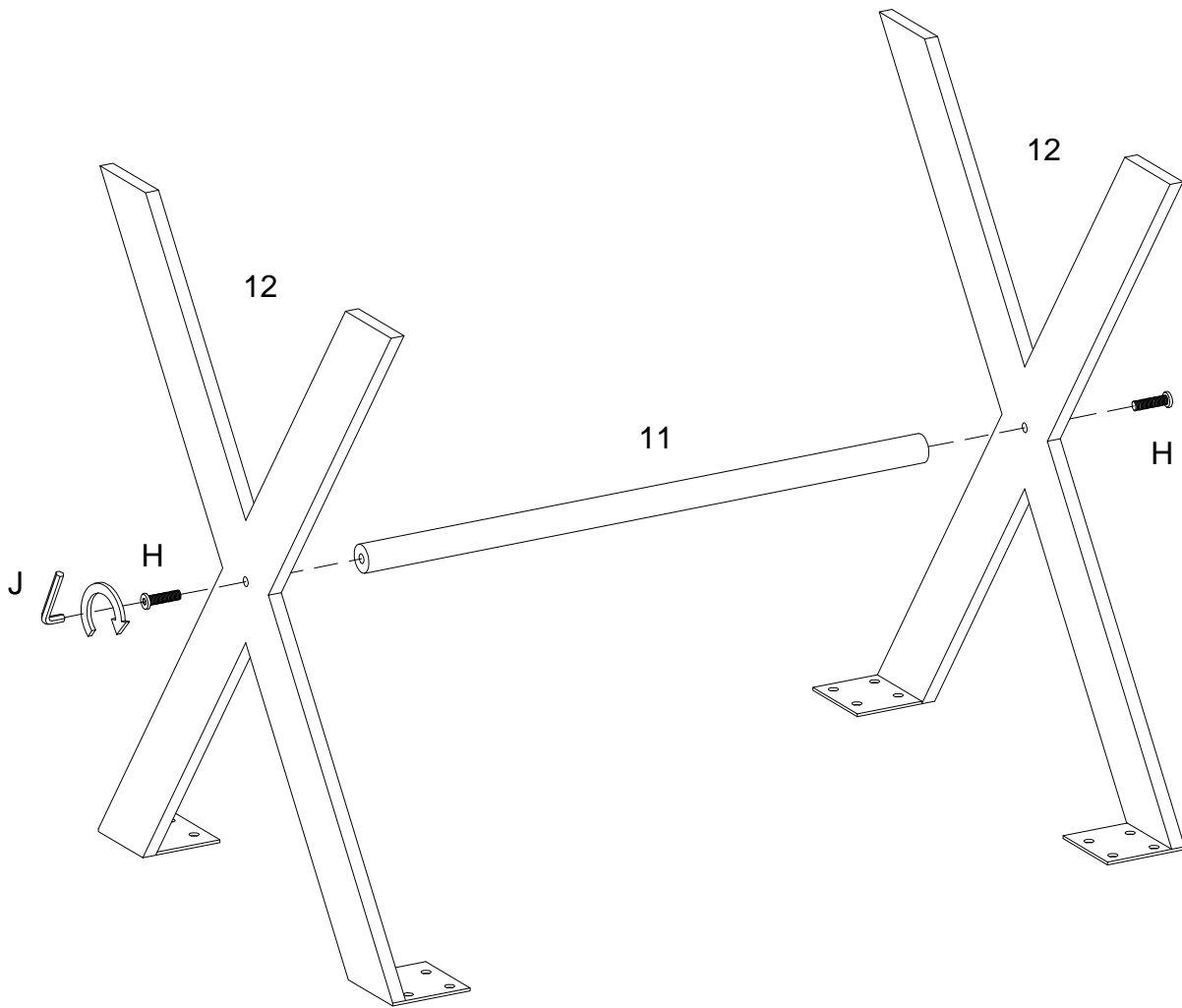

Using Bolt (H) attach part (12) to part (11) with Hex key (J) as per diagram.

Step 11

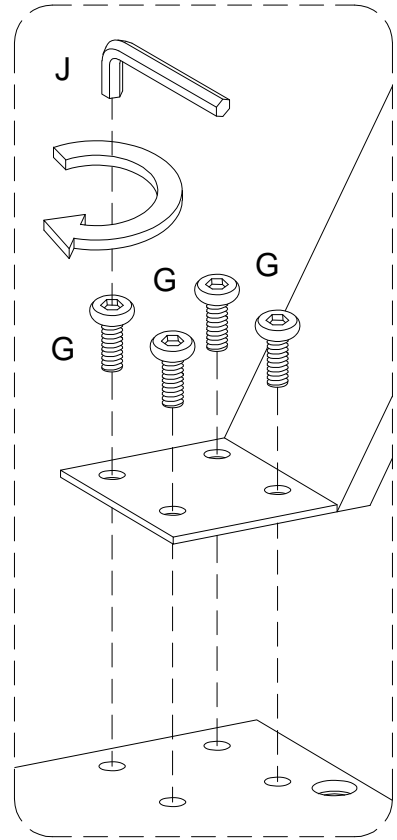
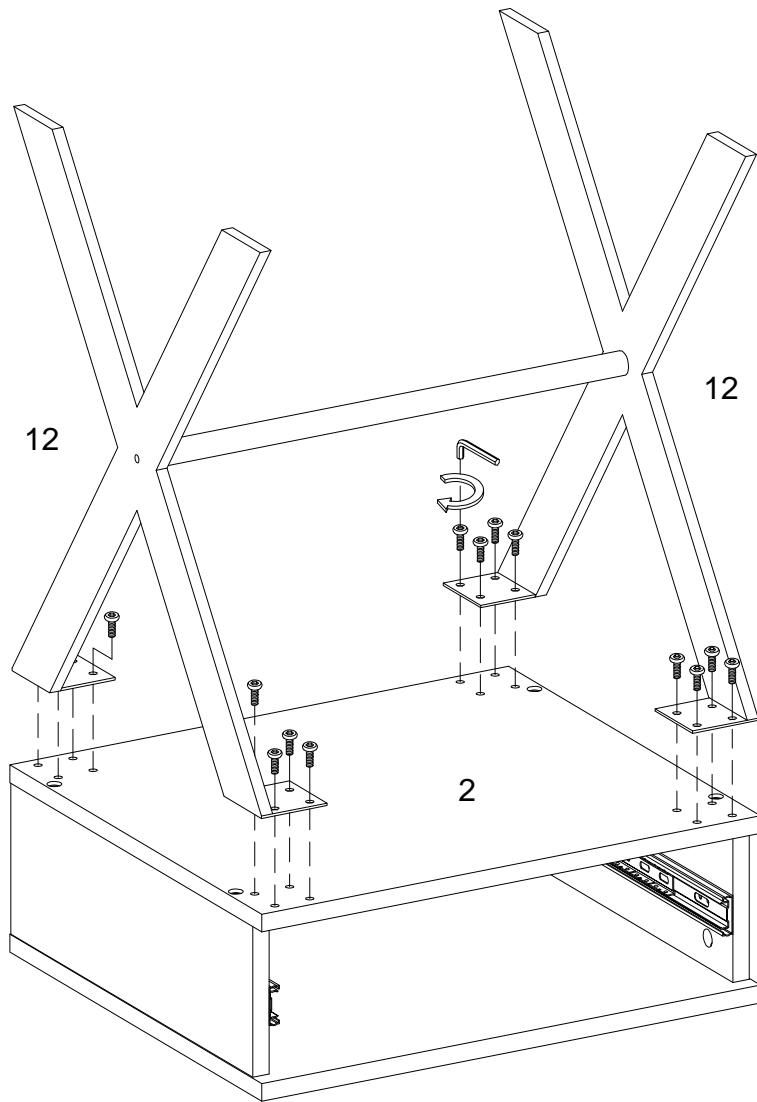

Using Bolt (G) attach part (12) to part (2) with Hex key (J) as per diagram.

Step 12

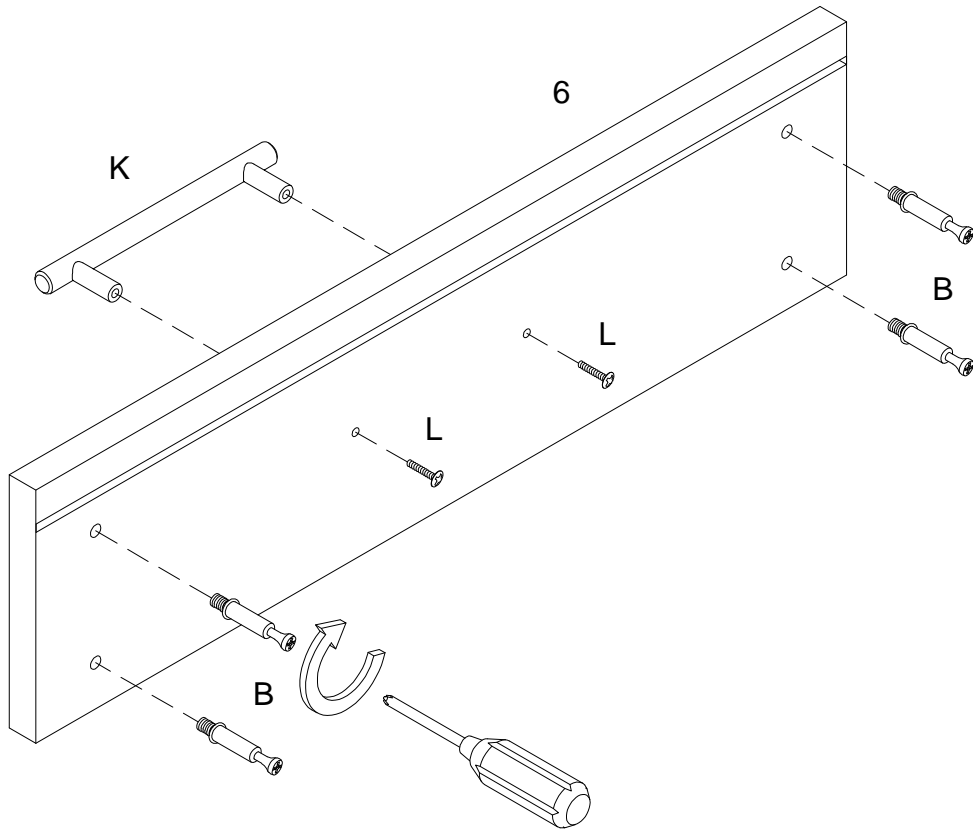

Secure cam bolt (B) into part (6), then using handle bolt (L) attach handle (K) to part (6) with Philips head screwdriver as per diagram.

Step 13

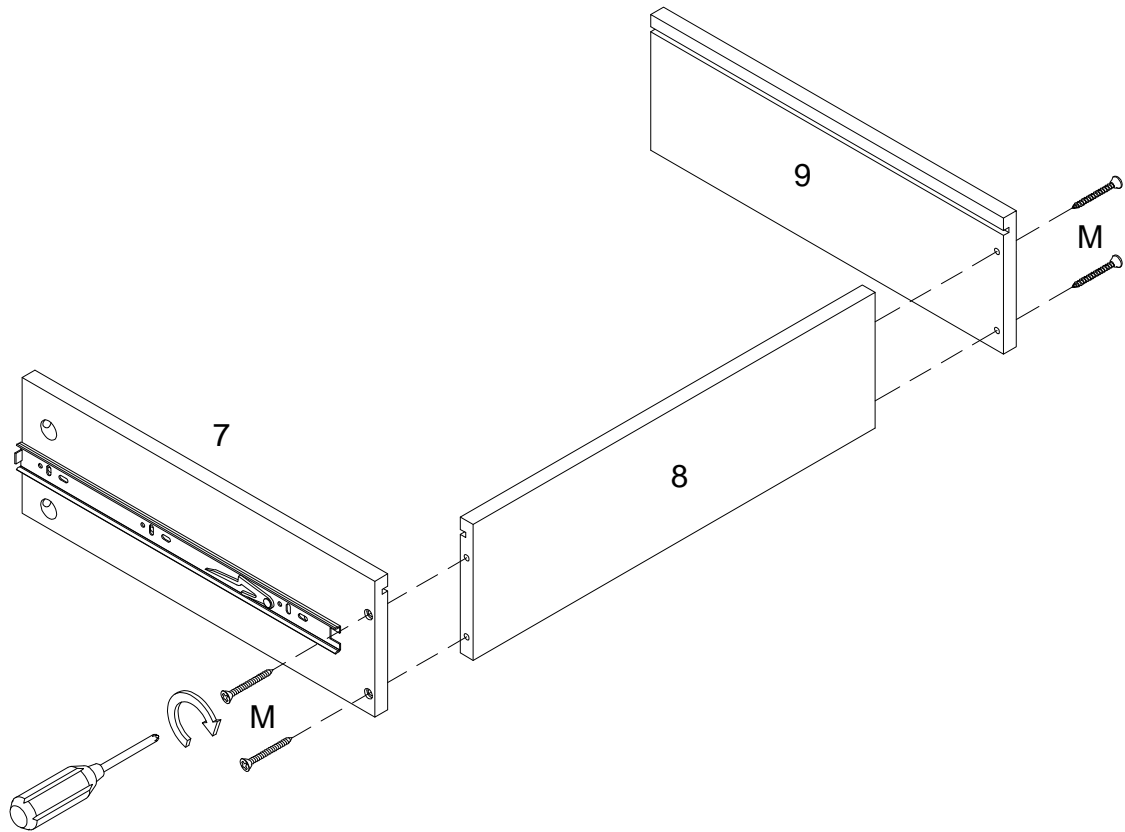

Using Screw (M) attach parts (7,9) to part (8) with Philips head screwdriver as per diagram.

Step 14

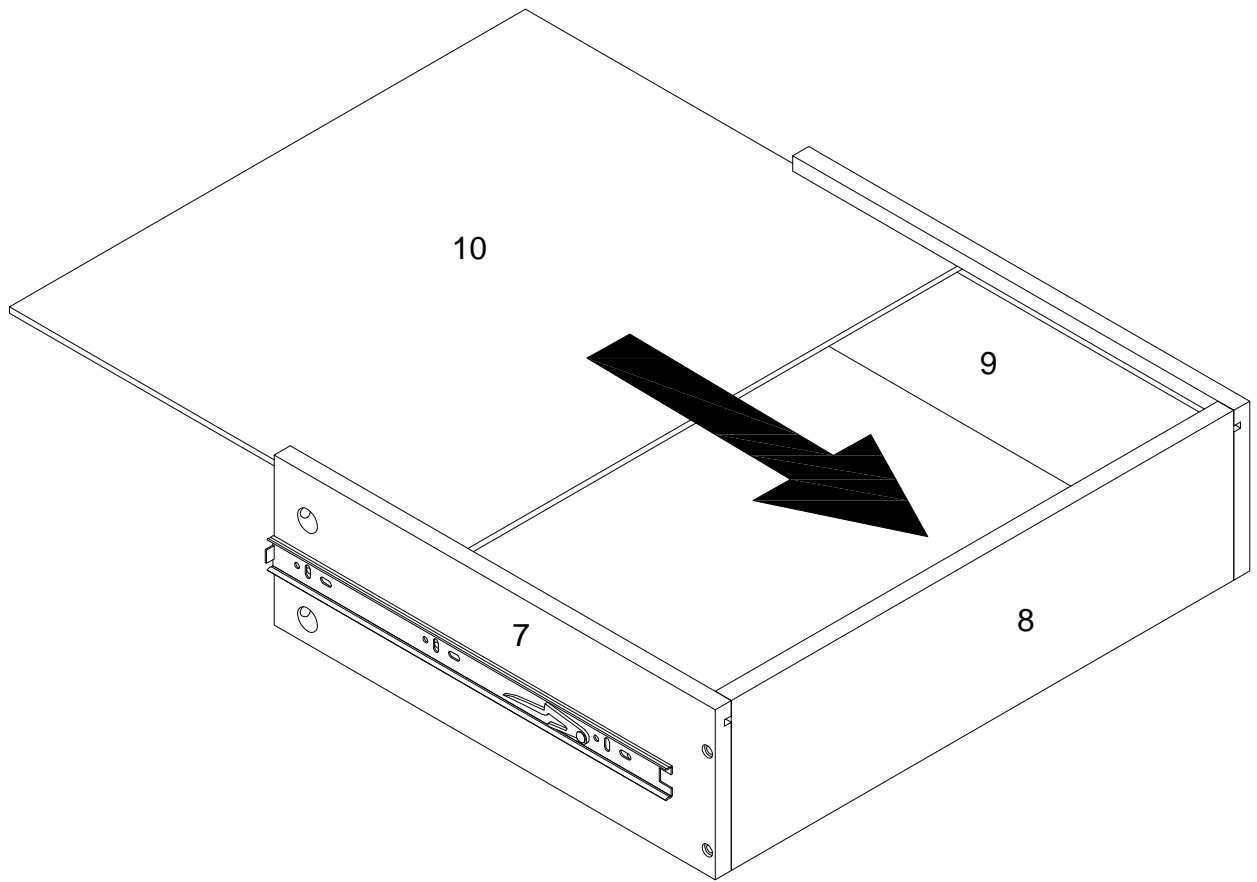

Put part (10) as per diagram.

Step 15

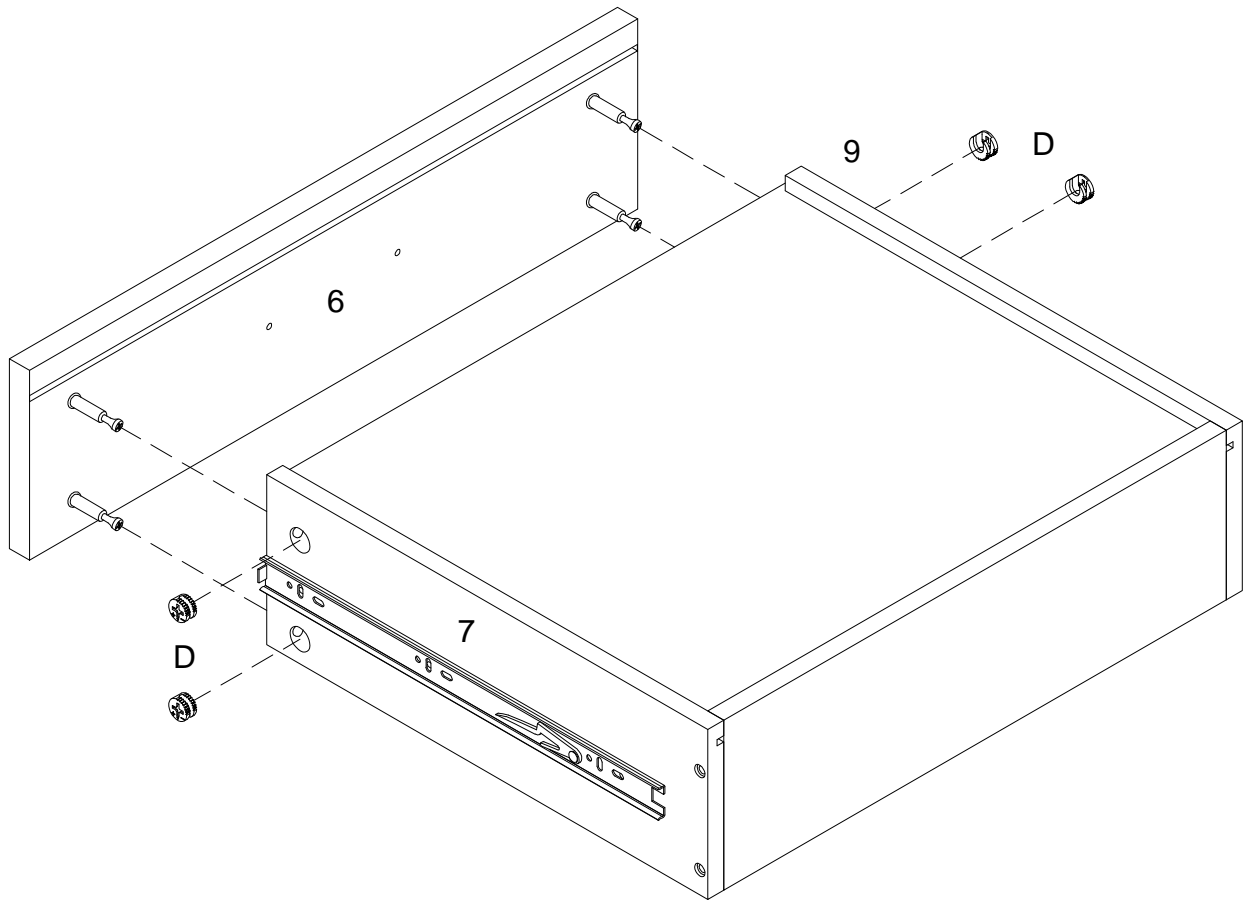
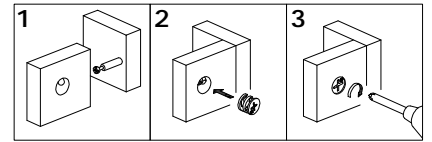

Using Cam lock(D) secure part (6) to parts (7,9) with Philips head screwdriver as per diagram.

Step 16

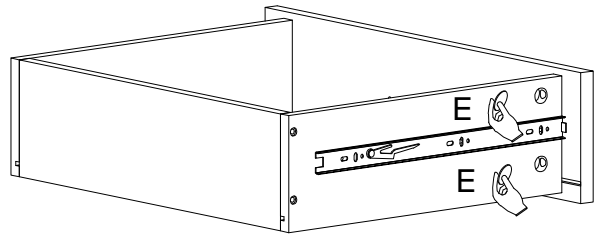
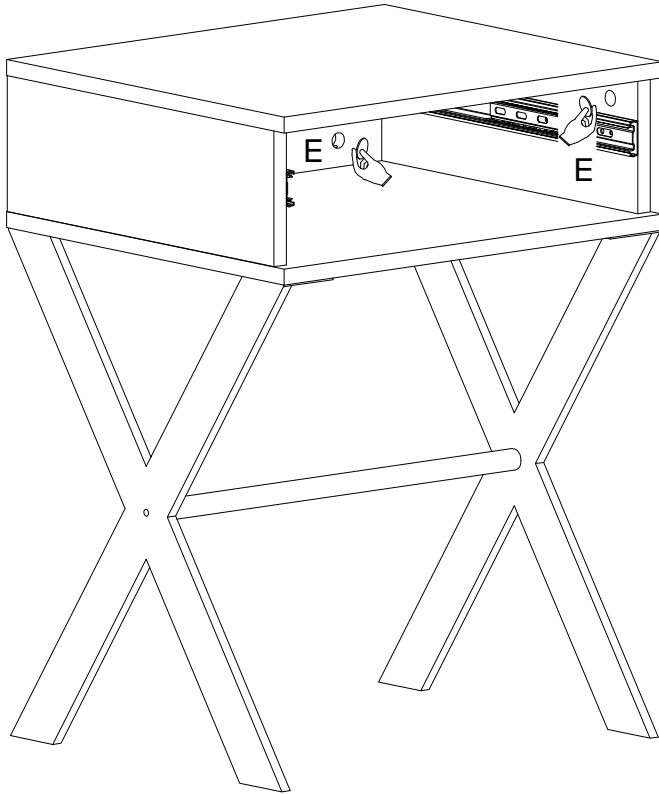

Place sticker (E) cover the holes as per diagram .

Step 17

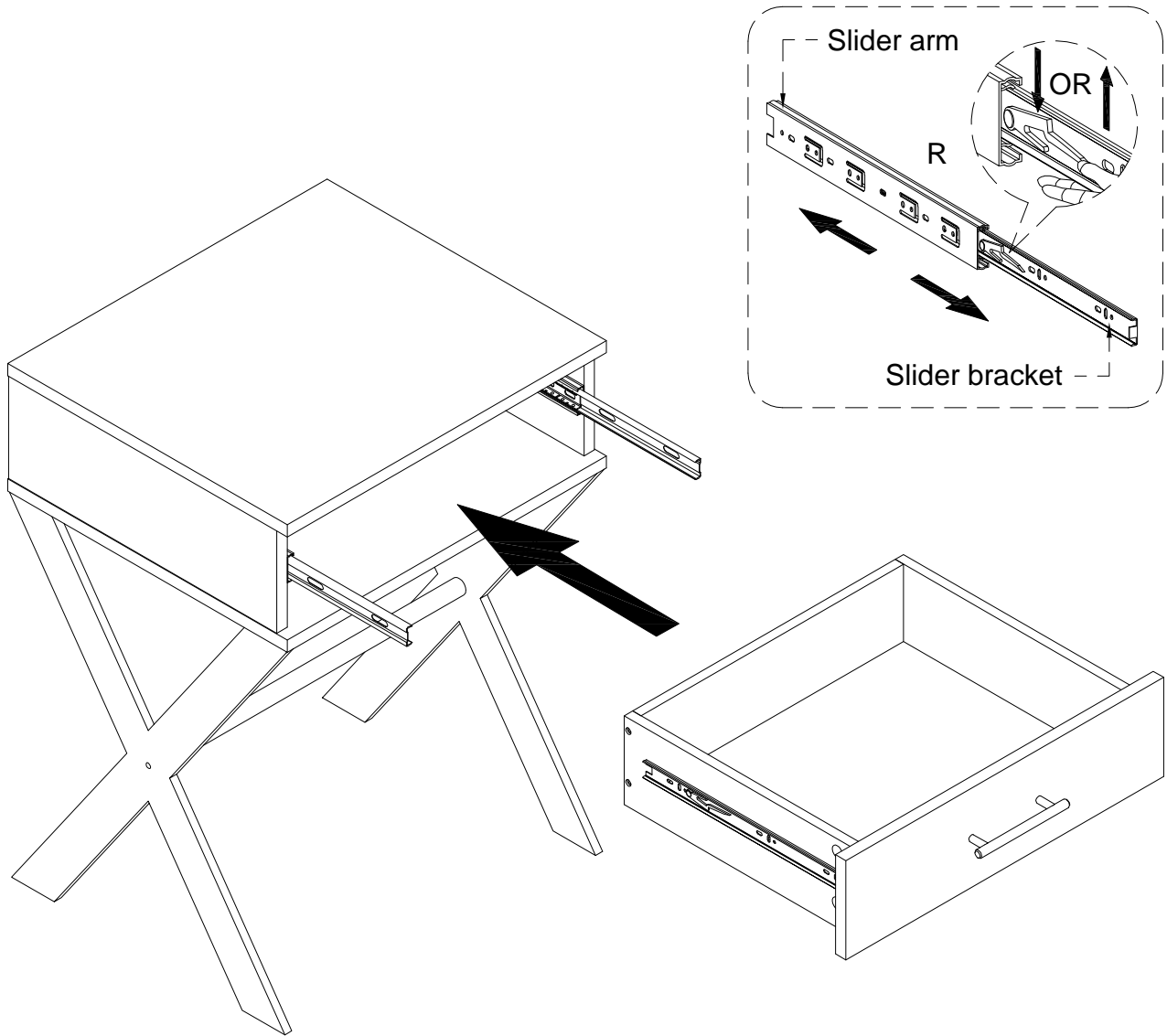

Assembled the drawer as per diagram

Note :If the drawer does not go in smoothly .Press or lift the plastic release lever .Pull out the slider bracket from the slider arm then re-assembled the drawer until they were going in smoothly well .

Step 18



Final Assembly