

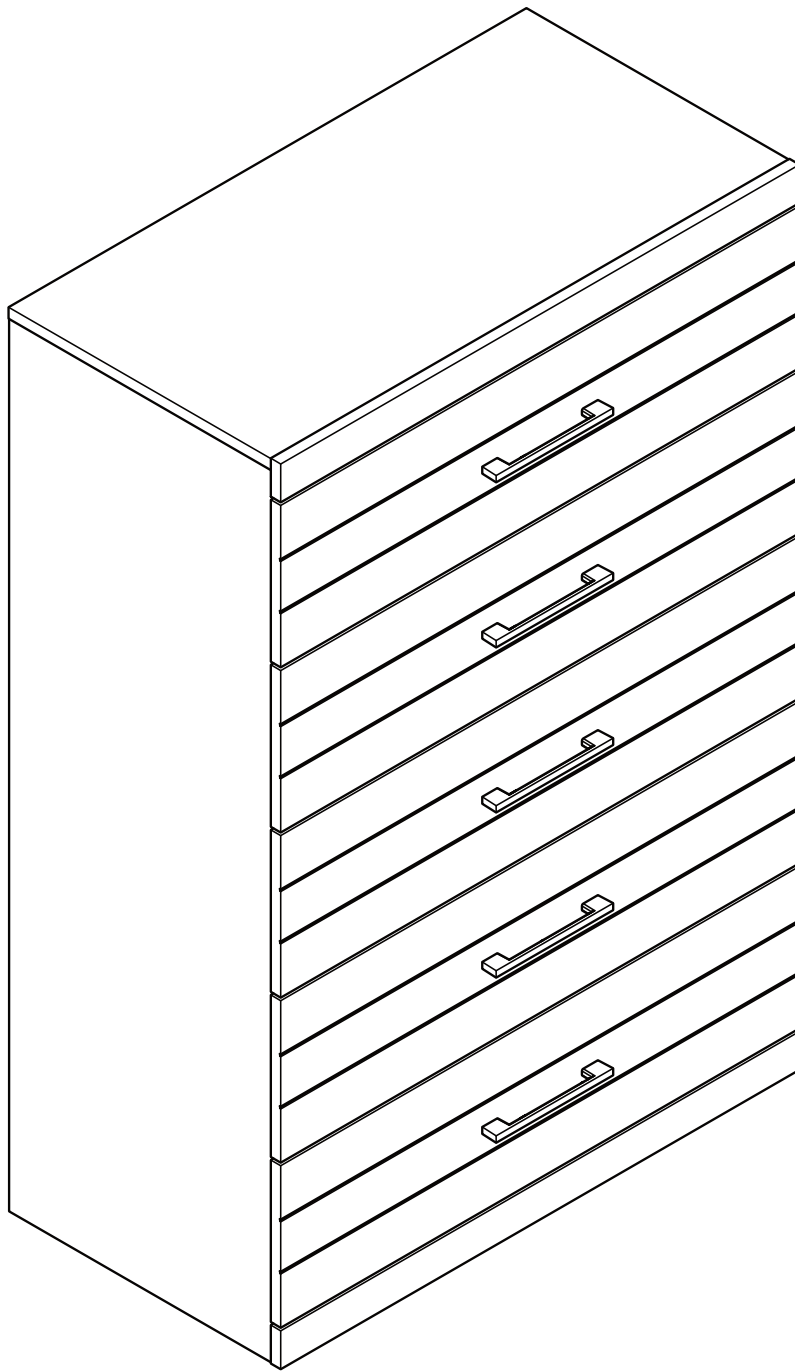





**ASSEMBLY INSTRUCTIONS / INSTRUCTIONS  
D'ASSEMBLAGE / INSTRUCTIVO DE ARMADO**



## NOTES ON ASSEMBLY / NOTES POUR L'ASSEMBLAGE / NOTAS SOBRE EL ENSAMBLE

- To ensure ease of assembly read all instructions before assembly and follow step by step illustrations.
- Keep instructions for future use.
- Adult assembly required.  2 person required. 
- Due to the presence of small parts during assembly, keep out of reach of children until assembly is complete.

- Pour assurer l'assemblage facile veuillez lire toutes les instructions avant l'assemblage et veuillez suivre les illustrations pour chaque etapes.
- Veuillez garder ces instructions pour l'usage ulterieur.
- Assemblage requis pas un adulte.  2 personnes requises. 
- Due a la presence de petite pieces durant l'assemblage, veuillez garder hors de porter des enfants jusqu'a ce que l'assemblage soit completer.

- Para garantizar la facilidad de ensamble lea las instrucciones antes de iniciar y siga paso a paso las ilustraciones.
- Guarde las instrucciones para futuras referencias.
- El ensamble requiere de un adulto.  2 personas requeridas. 
- Debido a que hay piezas pequeñas, mantenga fuera del alcance a los niños durante el ensamble, hasta que haya terminado.

## MAINTENANCE TIPS / CONSEILS D'ENTRETIEN / CONSEJOS DE MANUTENIMIENTO

- Never let liquids or damp cloths sit on this furniture.
- Never use chemical cleaning products. They can damage the finish. For cleaning, use only a slightly damp cloth and wipe dry.
- To avoid dulling of the finish, do not place furniture in direct sunlight.
- Do not put plastic or rubber rings under appliances. Use cloth of felt protectors.
- To clean, use a soft or slightly damp cloth, then wipe with a clean, dry cloth.

- Ne jamais laisser de liquide ou linge humide sur le meuble.
- Ne jamais utiliser de nettoyeurs à base de produits chimiques, cela va endommager le fini. Utiliser seulement un linge légèrement humide.
- Ne pas placer le meuble directement au soleil pour prévenir le ternissement.
- Évitez de déposer des appareils avec des rondelles de plastique ou de caoutchouc. Utilisez un protecteur en tissu ou en feutre.
- Pour nettoyer, utilisez un linge doux ou légèrement humecté. Essayez par la suite avec un linge propre et sec.

- Nunca deje un líquido o un trapo húmedo sobre el mueble.
- Nunca utilice limpiadores a base de químicos, estos dañaran le acabado. Use sólo un paño húmedo.
- No esponga el mueble directamente al sol para prevenir empañamiento.
- Evite apoyar aparatos con redondeles de plástico o de goma. Utilizar un protector de tela o de fieltro.
- Para limpiar, utilice un trapo suave o ligeramente humedecido. Seque luego con un trapo limpio y seco.

# WARNING AVERTISSEMENT / ADVERTENCIA

Please use your correctly and safely. Improper use can cause safety hazards, or damage to your or household items.

Serious or fatal crushing injuries can occur tip-over. To help prevent tip-over:

- Place heaviest items in the lowest drawers.
- Do not set TVs or other heavy objects on the top of this product. Never allow children to climb or hang on drawers, doors, or shelves.
- Never open more than one drawer at a time.
- Always monitor your child's activity when in the nursery.
- Do not allow standing in drawers.
- Do not allow standing on top of this product.
- Accessory Items must be securely fastened to this product according to the instructions provided with those items.
- To avoid head injury, do not allow children to play underneath open drawers.
- Do not leave drawers open when not in use.

Use of tip-over restraints reduce, but does not eliminate, the risk of tip-over.

Prrière d'utiliser le mobilier à bon escient et avec prudence. Une mauvaise utilisation peut être à l'origine de risques d'accident ou peut endommager le mobilier et les articles ménagers.

Des blessures graves ou fatales peuvent résulter de basculement du meuble.

Afin de prévenir le basculement :

- Placer les items les plus lourds dans les tiroirs du bas.
- Ne pas placer de TV ou d'autres objets lourds sur ce produit. Ne jamais laisser un enfant grimper sur les tiroirs, les portes et les tablettes ou s'accrocher à ceux-ci.
- Ne jamais ouvrir plus d'un tiroir à la fois.
- Toujours surveiller votre activité de l'enfant lorsqu'à la pépinière.
- Ne pas laisser debout dans des tiroirs.
- Ne pas laisser debout sur ce produit.
- Les accessoires doivent être solidement fixés sur ce produit selon les instructions fournies avec ces éléments.
- Pour éviter toute blessure à la tête, ne pas laisser les enfants jouer sous les tiroirs ouverts.
- Ne pas laisser ouvrir les tiroirs lorsqu'il n'est pas utilisé.

L'utilisation de dispositif antibasculement ne peut que réduire les risques de basculement, sans les éliminer

Por favor use el mobiliario correcta y seguramente. El mal uso puede causar riesgos de seguridad o daño a las unidades o artículos domésticos.

El vuelco del mueble puede ser causa de lesiones graves o de un aplastamiento fatal.

Para evitar la volcadura:

- Ponga las cosas pesadas en los cajones más bajos.
- No ponga televisores u otros objetos pesados encima de este producto. Nunca permita que un niño se trepe o se cuelgue en cajones, puertas o estantes.
- Nunca abra más de un cajón a la vez.
- Siempre supervisa la actividad de su hijo cuando en el vivero.
- No dejar reposar en los cajones.
- No permiten de pie en la parte superior de este producto.
- Los elementos accesorios deben sujetarse firmemente a este producto de acuerdo a las instrucciones provistas con esos elementos.
- Para evitar lesiones en la cabeza, no permita que los niños jueguen debajo abrir cajones.
- No deje los cajones abiertos cuando no está en uso.

El uso de sujetadores para evitar el vuelco sólo puede disminuir el riesgo de un vuelco, pero no lo elimina.

**THINGS TO REMEMBER FOR ASSEMBLY**  
**CHOSSES À SE SOUVENIR POUR UNE ASSEMBLEE**  
**COSAS PARA RECORDAR EN UNA ASAMBLEA**

**MINIFIX BOLT**  
**BOULON MINIFIX**  
**PERNO MINIFIX**

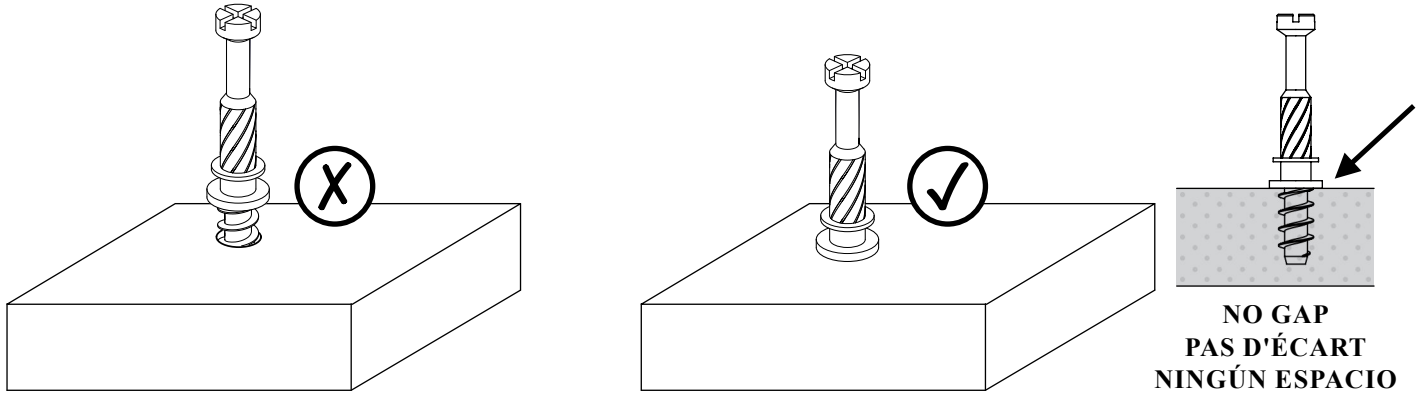

**MINIFIX CAM**  
**CAMÉRA MINIFIX**  
**CÁMARA MINIFIX**

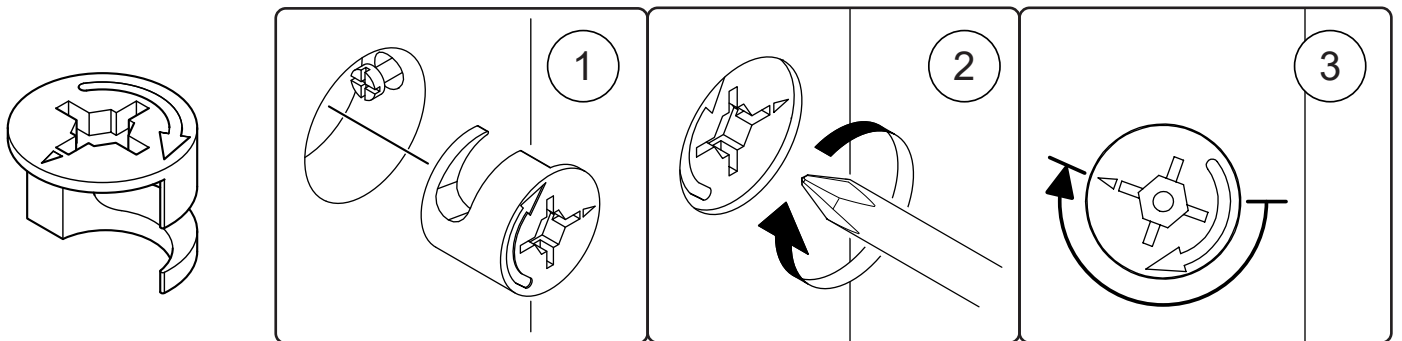



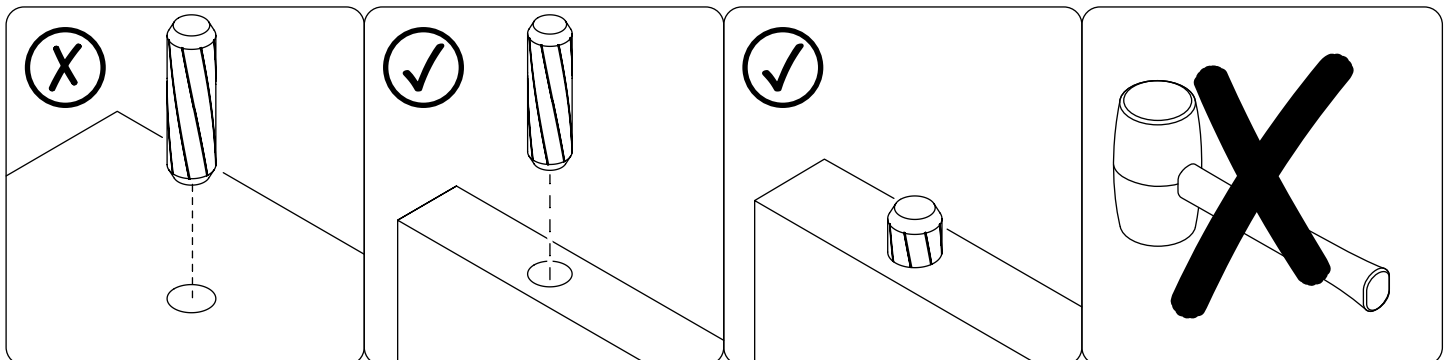



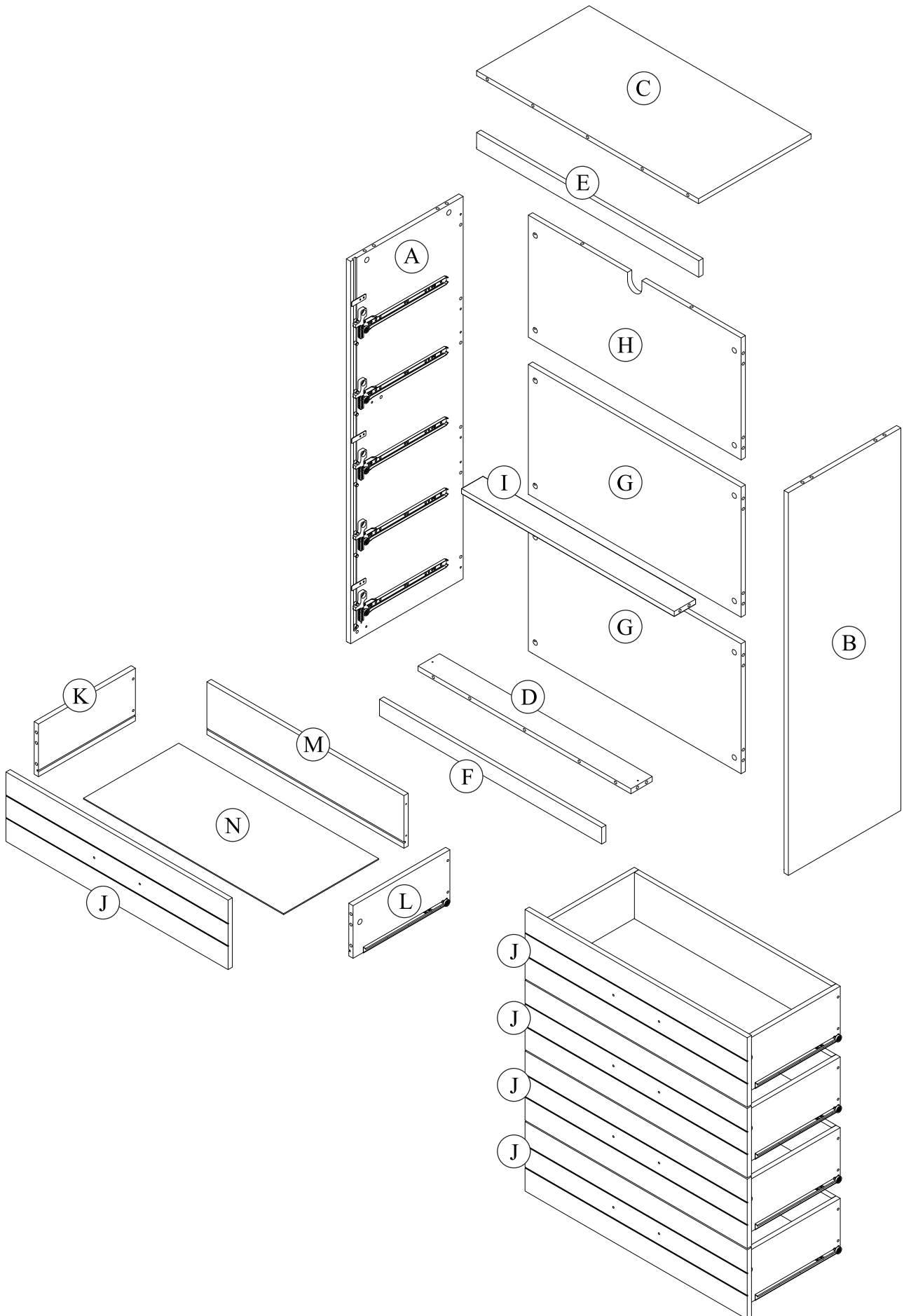

**WOOD DOWEL**  
**CHEVILLE BOIS**  
**PASADOR DE MADERA**

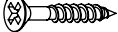

**PARTS IDENTIFICATION**  
**IDENTIFICATION DES PIÈCES**  
**IDENTIFICACIÓN DE LAS PARTES**

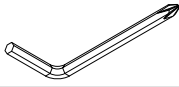
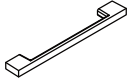





# HARDWARE QUINCAILLERIE / HERRAJE

(A)	Screw M4 x 38mm	(B)	Minifix Bolt EU 24	(C)	Screw M4 x 30mm
					
	20 units		36 units		10 units
(D)	Screw M3.1 x 20mm	(E)	Screw M3.5 x 15mm	(F)	Allen Philips Key
					
	10 units		4 units		1 unit
(G)	Handle 176mm	(H)	Back Ply Stopper	(I)	Dowel M8 x 30mm
					
	5 units		10 units		46 + 2 units
(J)	Minifix Cam 15/12	(K)	PVC L Bracket		
					
	36 units		2 units		

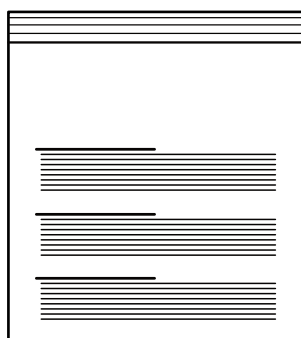
- Hardware quantity may supplied more than it required. Please keep spares and tools for future use.
- La cantidad de hardware puede suministrarse más de lo requerido. Guarde los repuestos y las herramientas para uso futuro.
- La quantité de matériel peut fournir plus que nécessaire. Veuillez conserver les pièces de rechange et les outils pour une utilisation future.

## FURNITURE TIPPING RESTRAINT SEGURO CONTRA VOLCADO DE MUEBLES DISPOSITIF DÉ SÉCURITÉ POUR MEUBLES



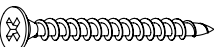

(AA)	Mounting L Bracket	(BB)	Washer M6 x 16mm
			
	1 unit		1 unit
(CC)	Screw #10 x 16mm	(DD)	Screw M4 x 38mm
			
	1 unit		1 unit

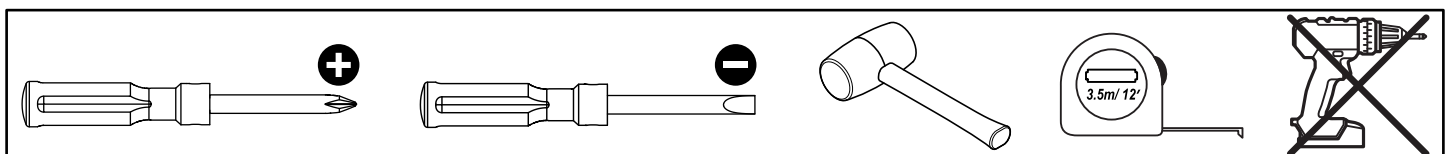
## TOOLS NOT INCLUDED OUTILS PAS INCLUS / HERRAMIENTAS NO INCLUIDAS

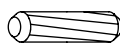

# STEP 1

Layout parts on soft surface.

	
I x 2	B x 8

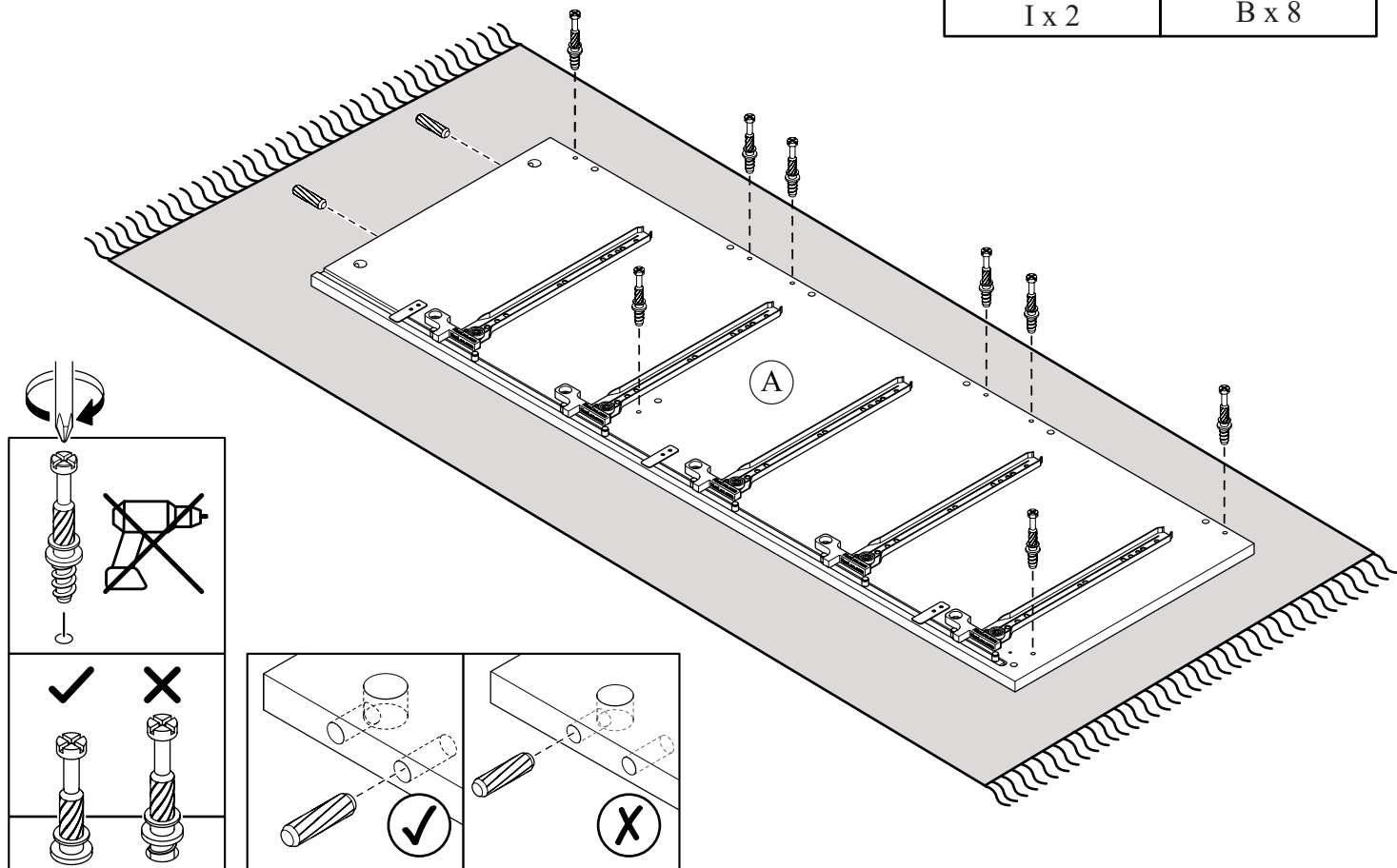

# STEP 2

I x 14

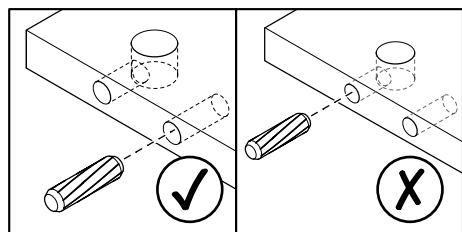
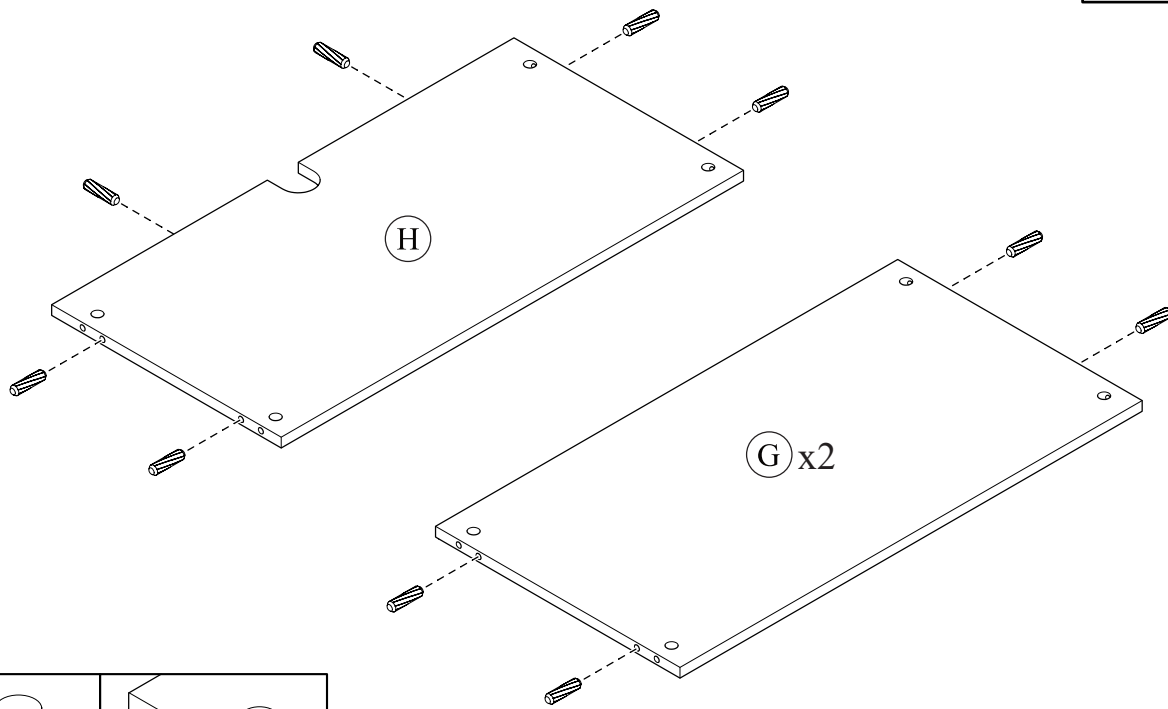

### STEP 3

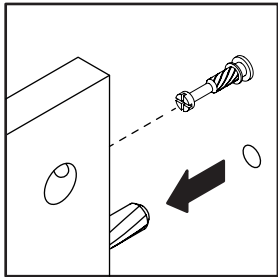
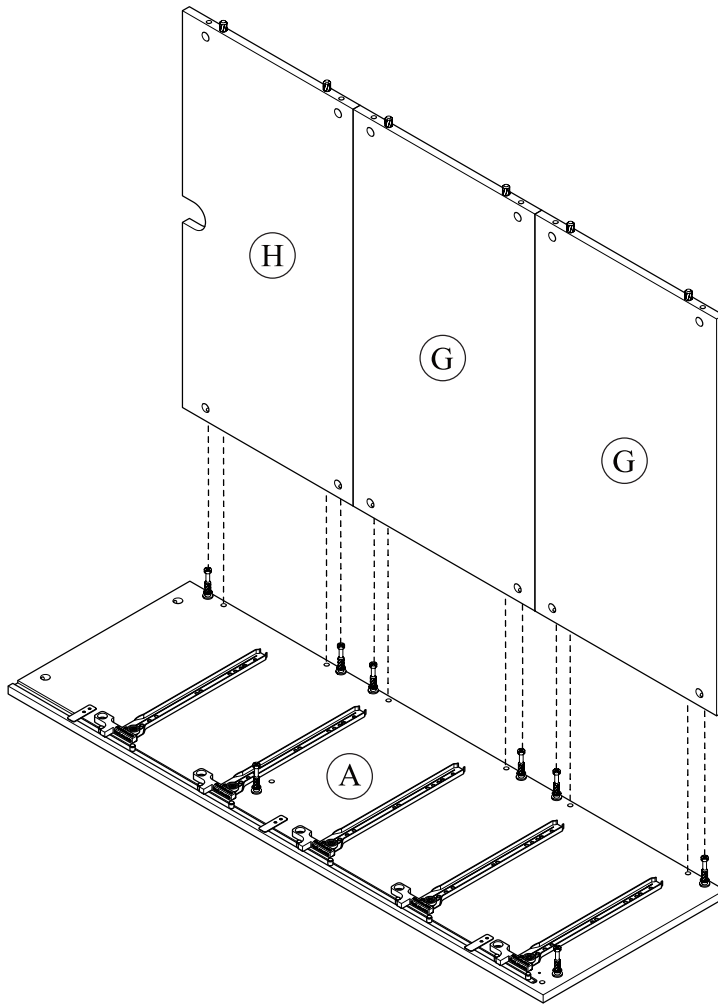



### STEP 4

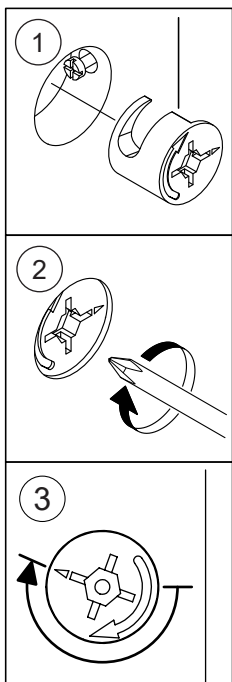
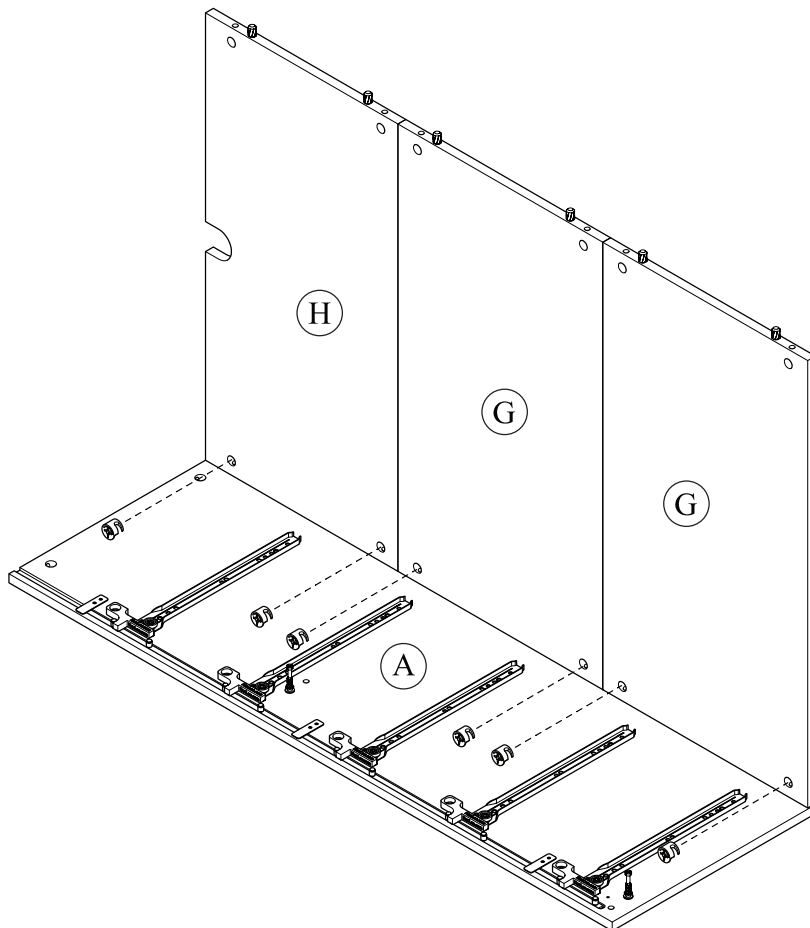

J x 6



# STEP 5

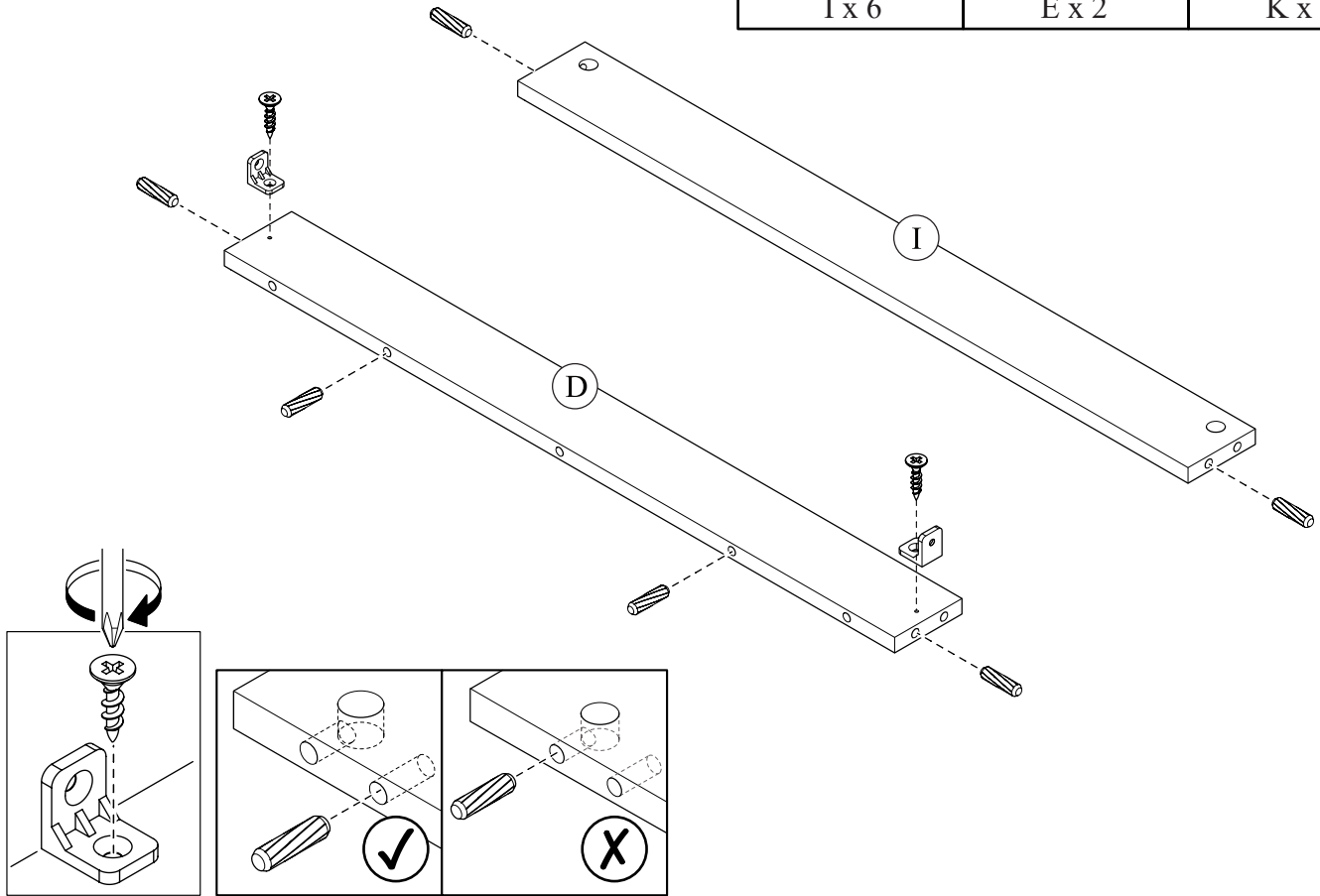

		
I x 6	E x 2	K x 2

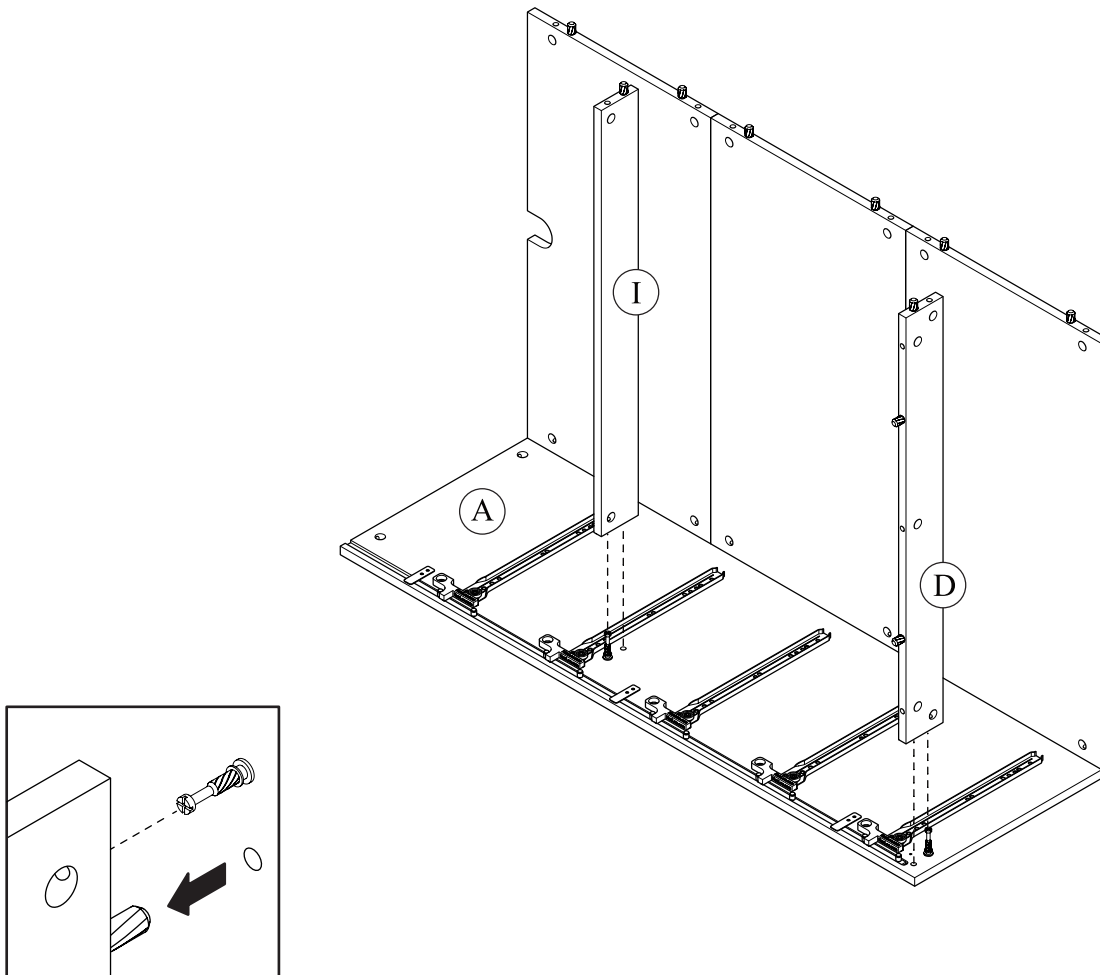

# STEP 6



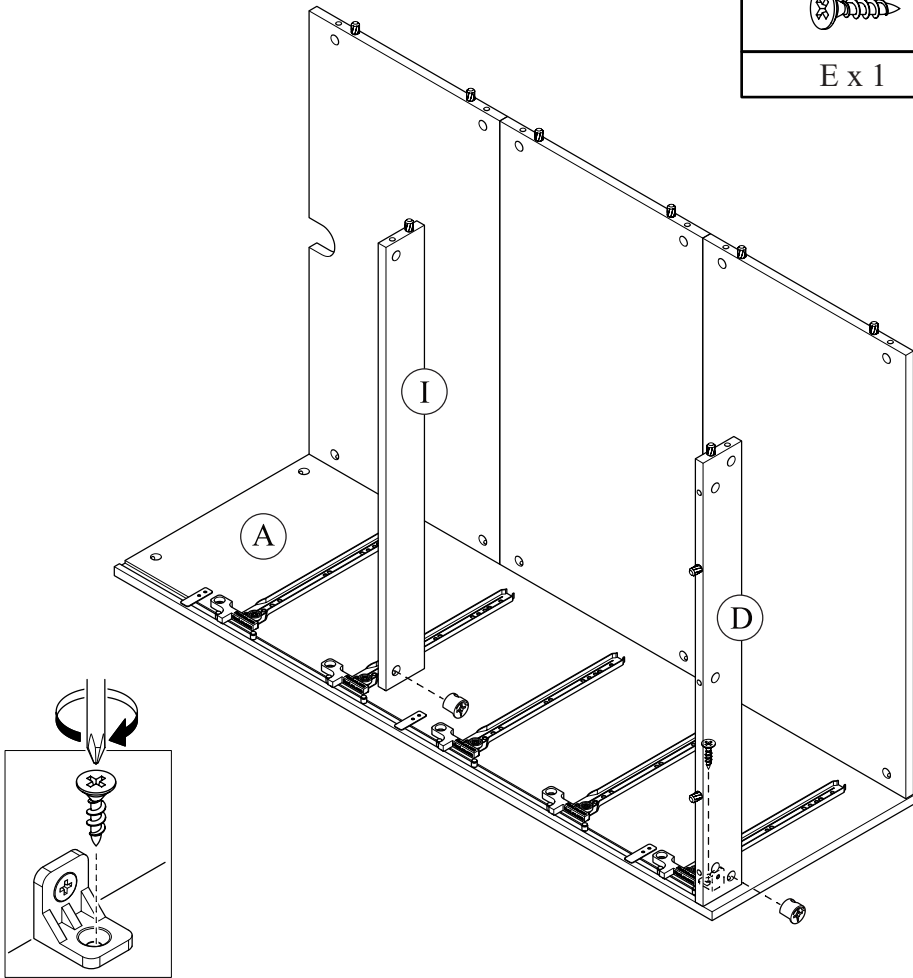
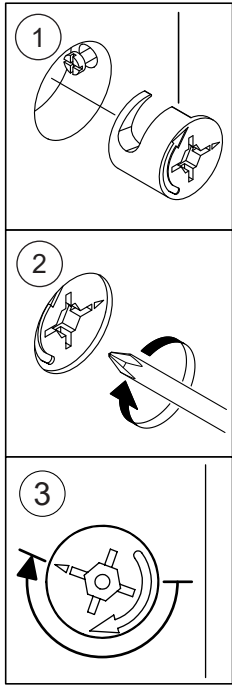

# STEP 7

	
E x 1	J x 2



# STEP 8

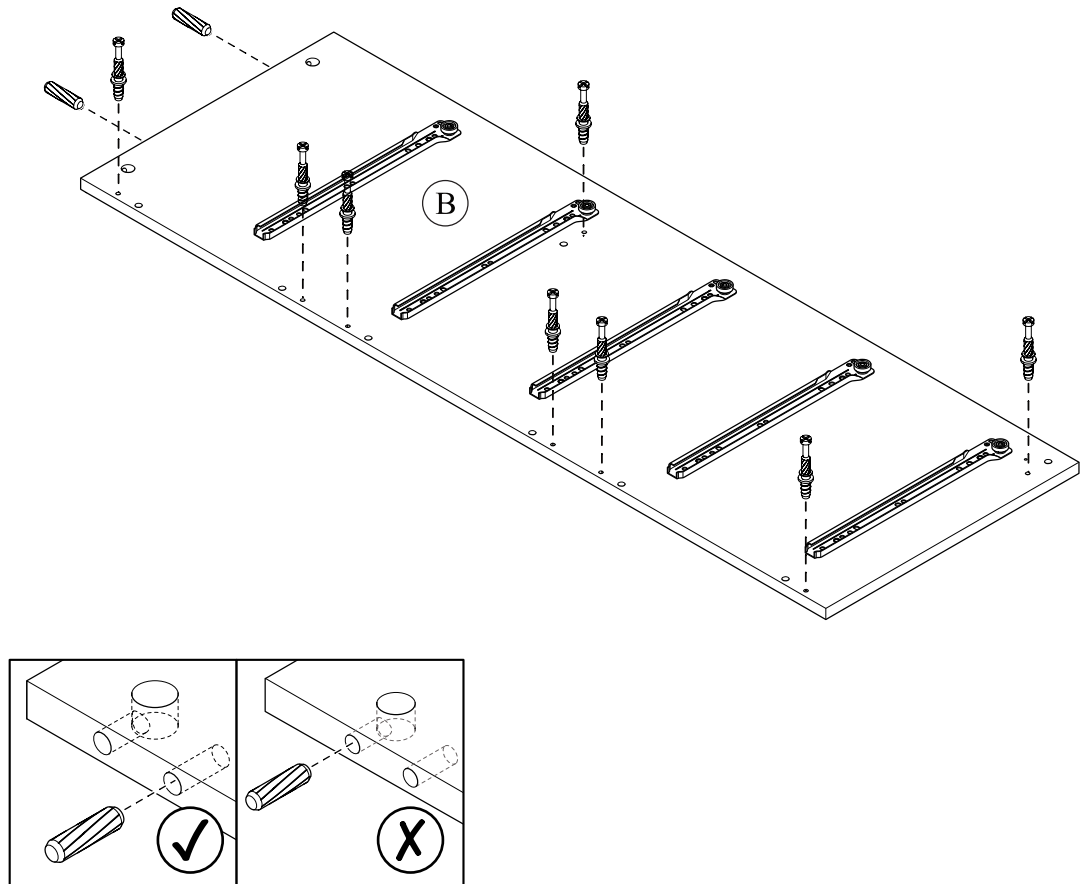
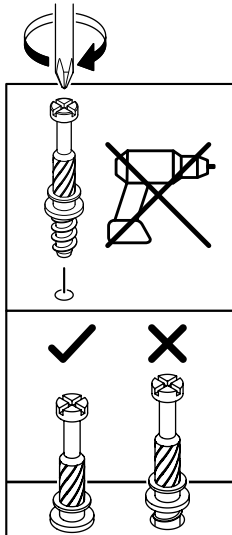

	
I x 2	B x 8

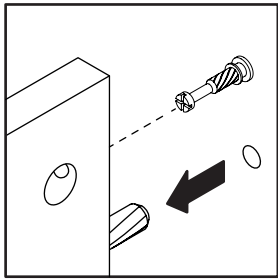
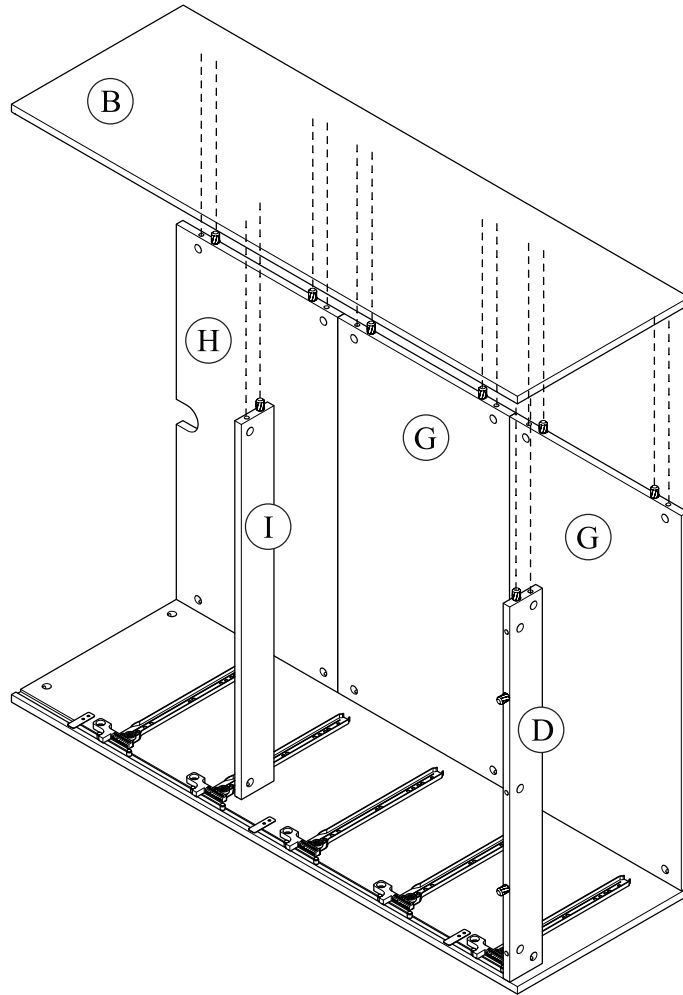

# STEP 9





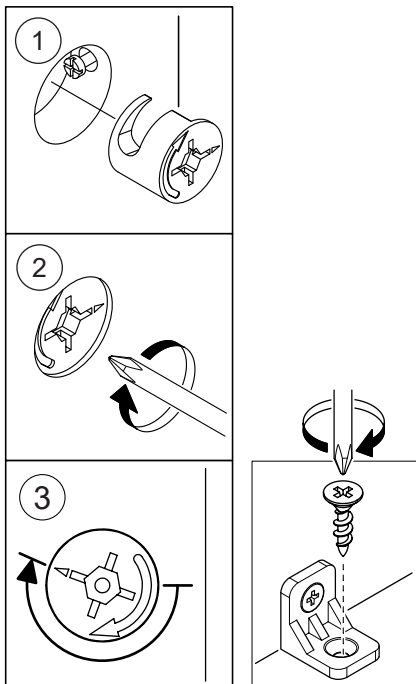
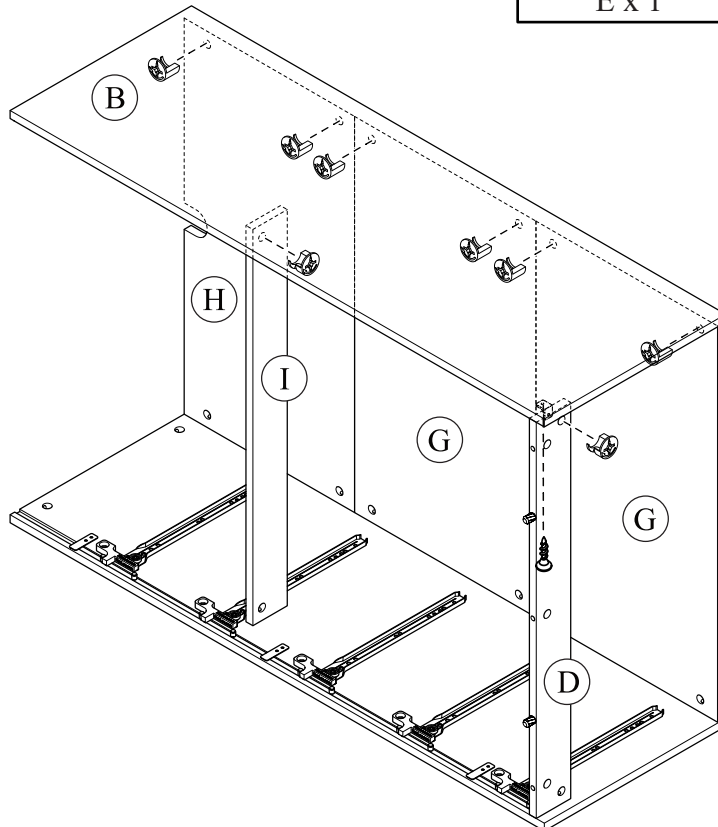

# STEP 10

	
E x 1	J x 8

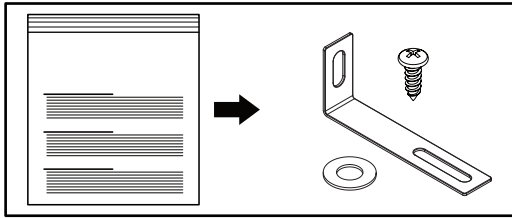

# STEP 11



			
B x 10	AA x 1	BB x 1	CC x 1

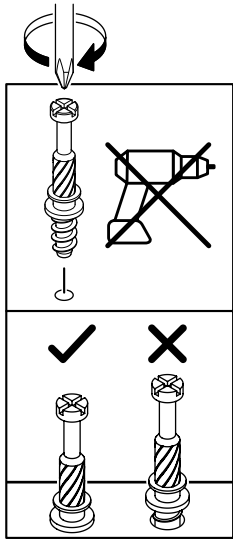
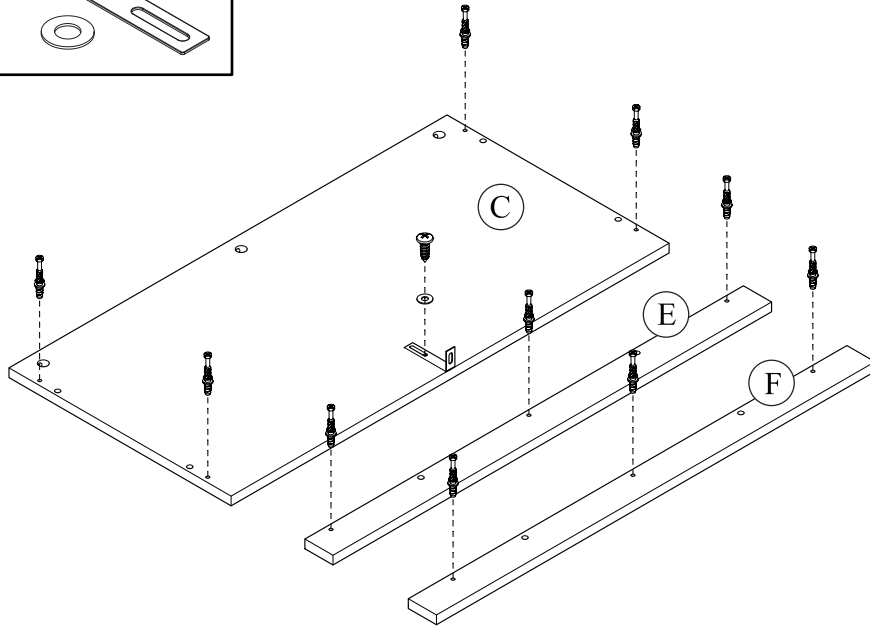

DO NOT TIGHTEN  
NE SERREZ PAS  
NO APRIETE

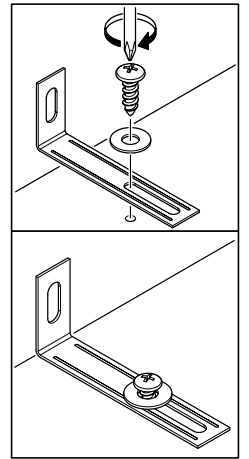

# STEP 12

I x 2

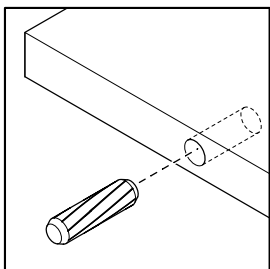
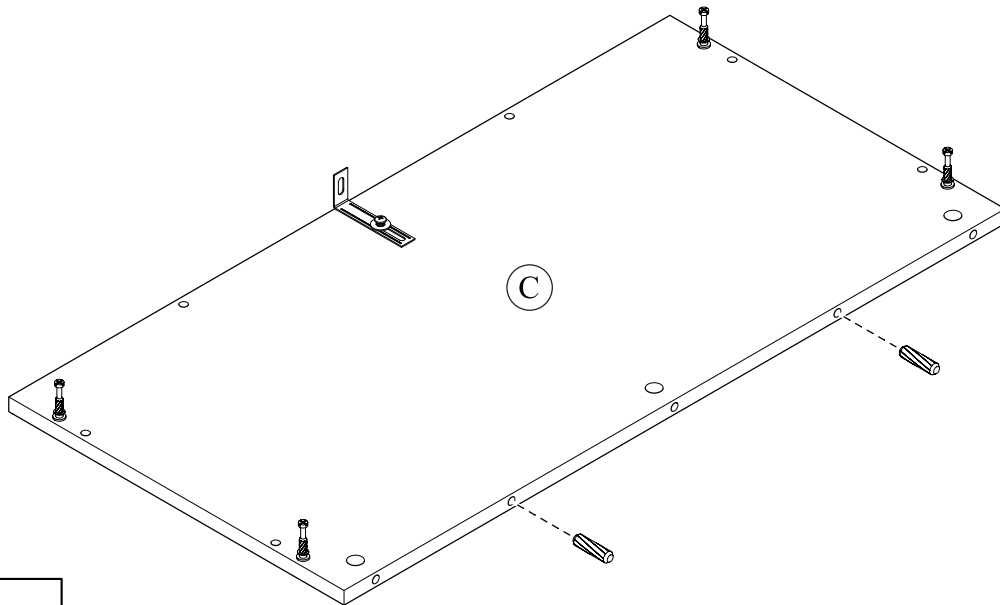

# STEP 13

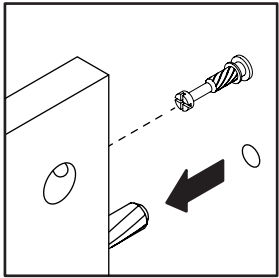
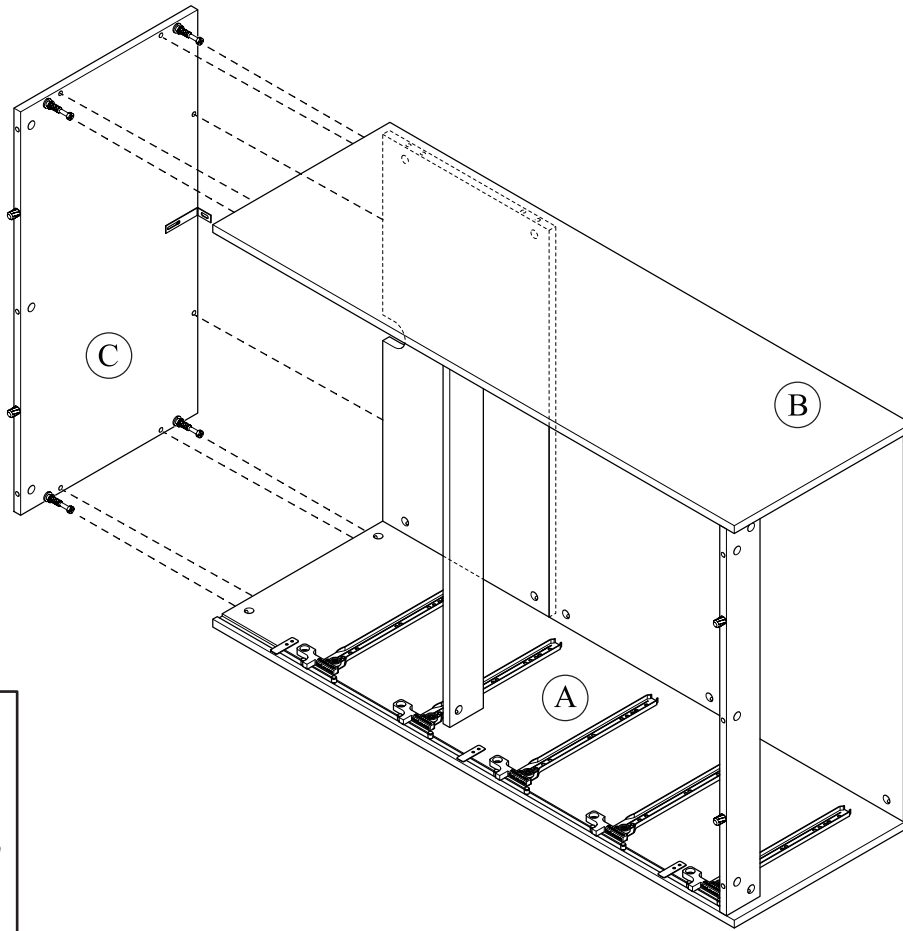

# STEP 14



J x 4

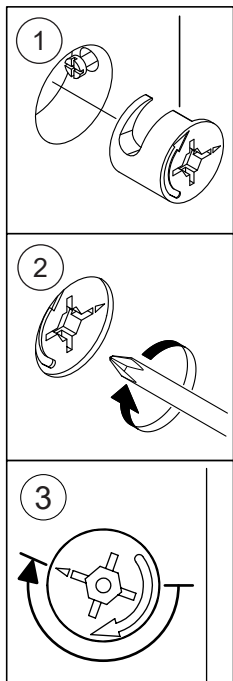
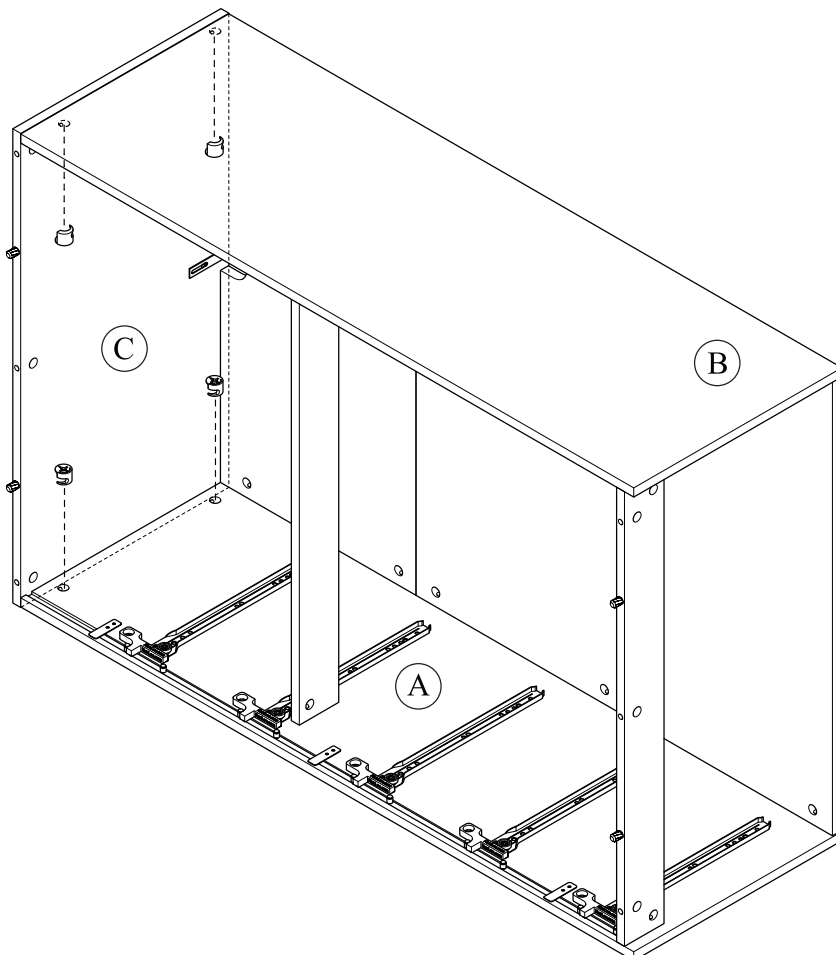

# STEP 15

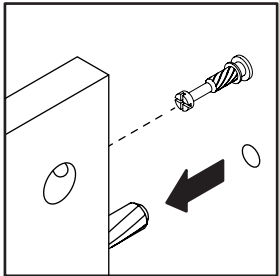
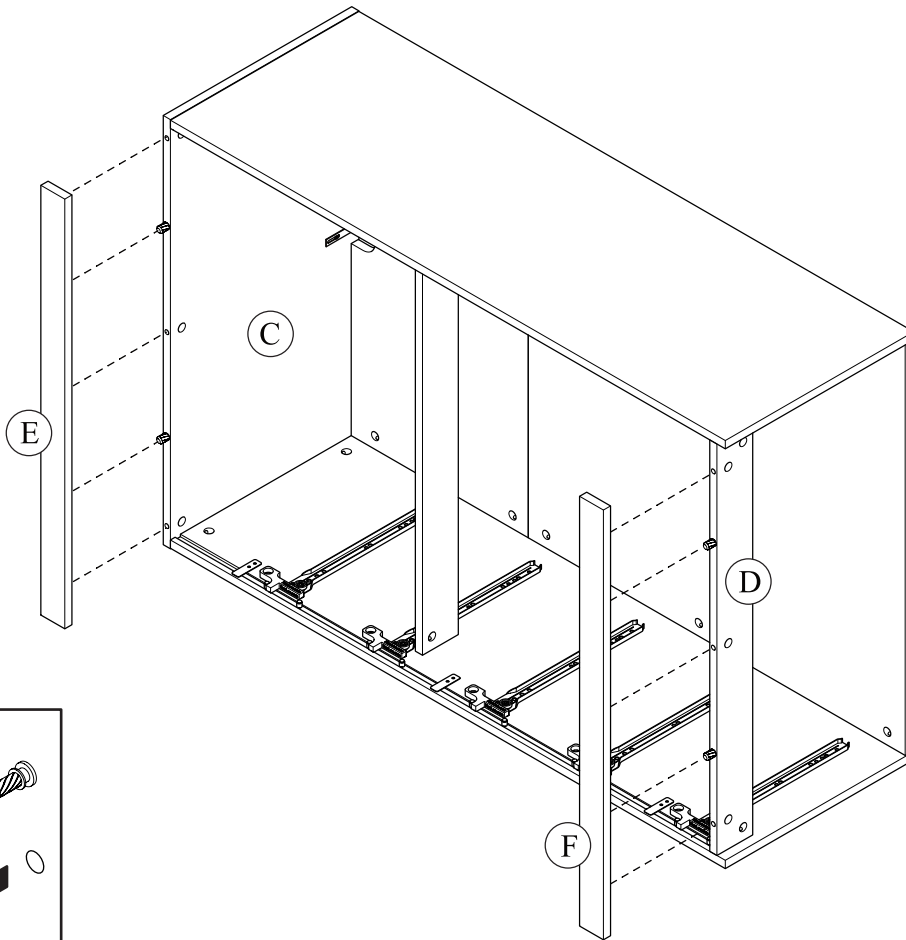

# STEP 16

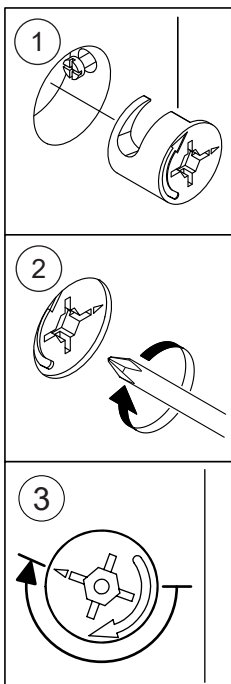
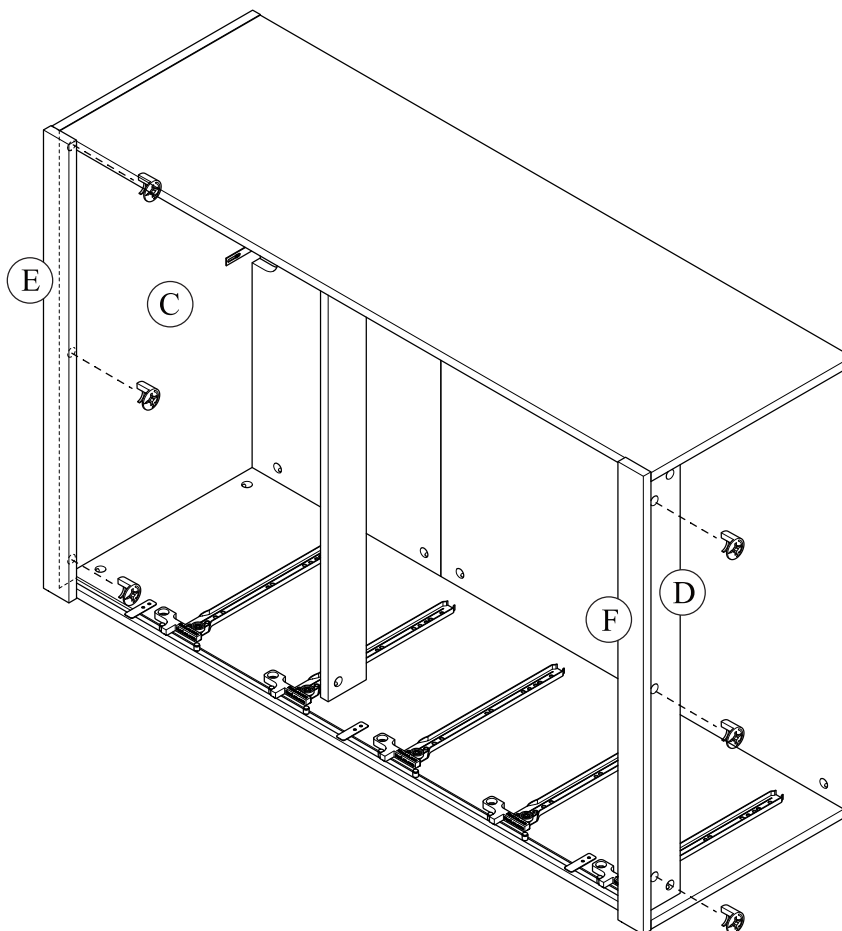
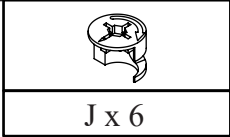

# STEP 17

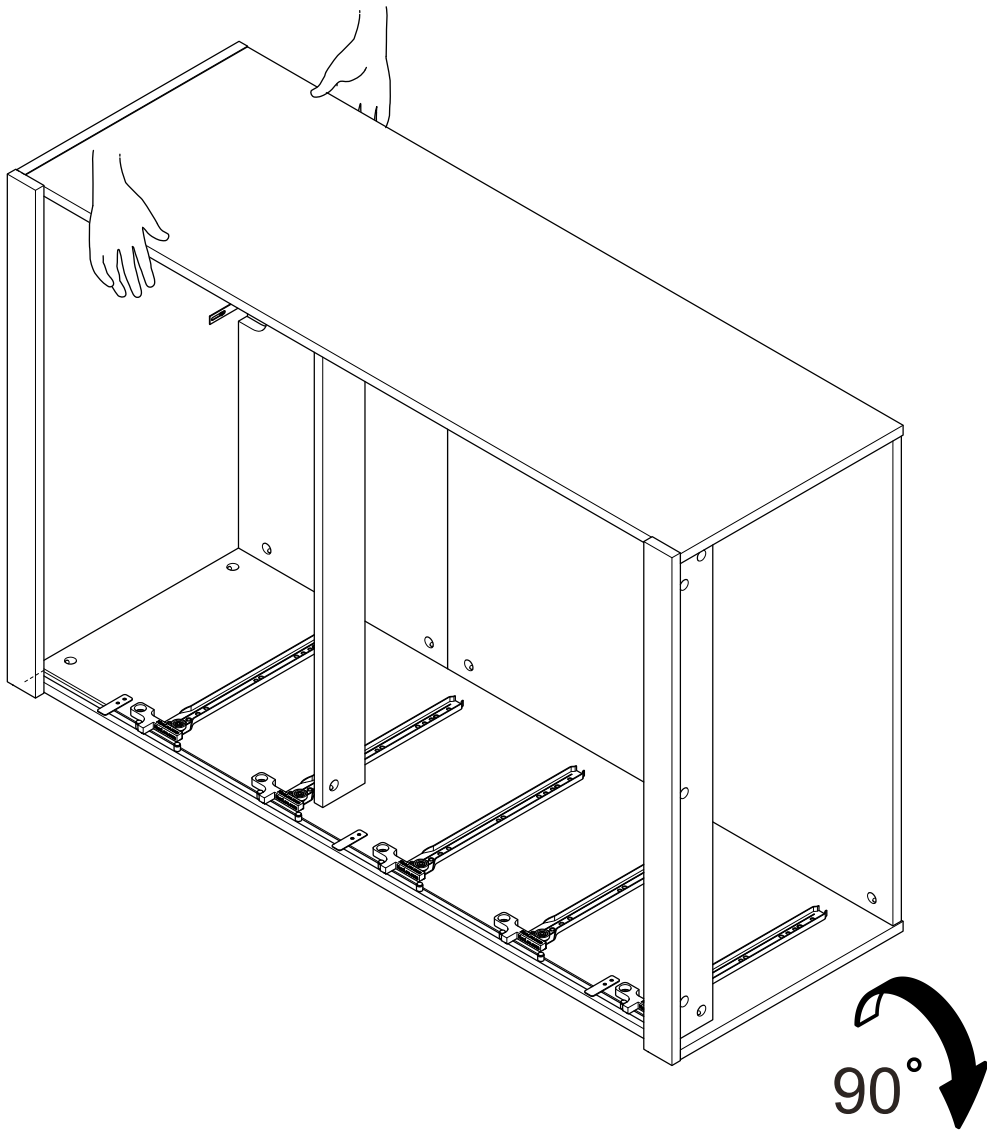

# FURNITURE TIPPING RESTRAINT

## SEGURO CONTRA VOLCADO DE MUEBLES

### DISPOSITIF DÉ SÉCURITÉ POUR MEUBLES

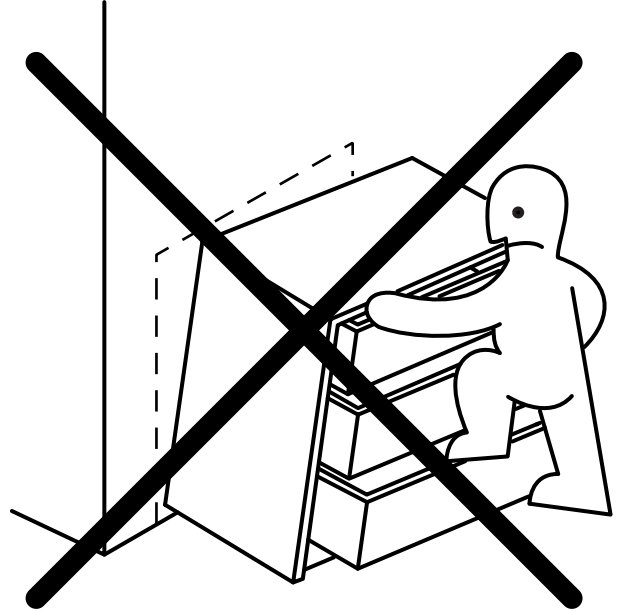
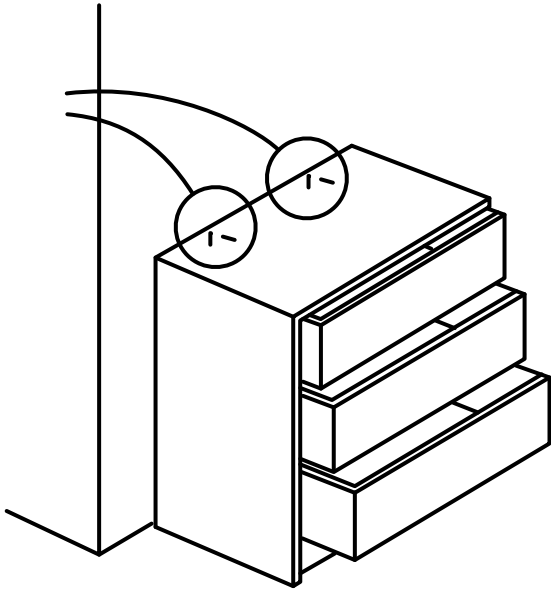

#### STEP 18

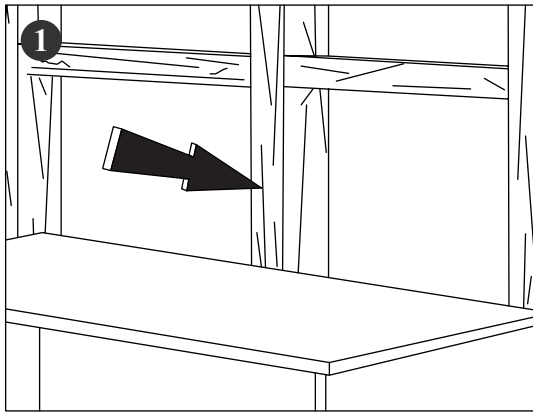

Locate a wall stud:

- Move the unit to its final position to the wall
- Locate a wall stud behind the unit

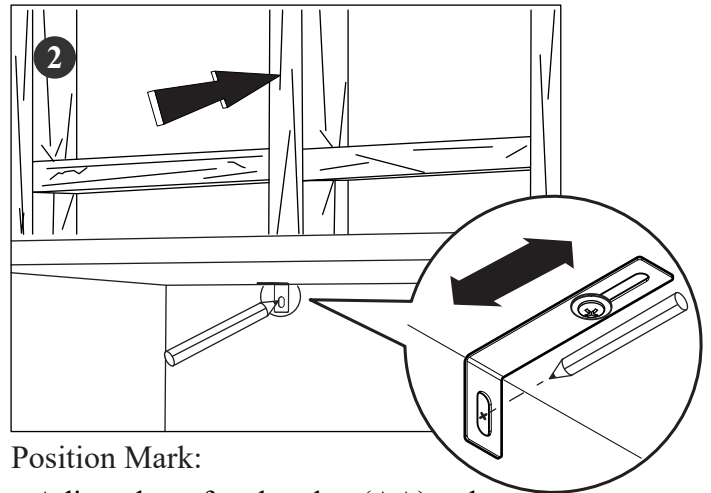

Position Mark:

- Adjust the safety bracket (AA) to be flush to the wall
- Use the Pencil to mark the positioning hole on a wall stud

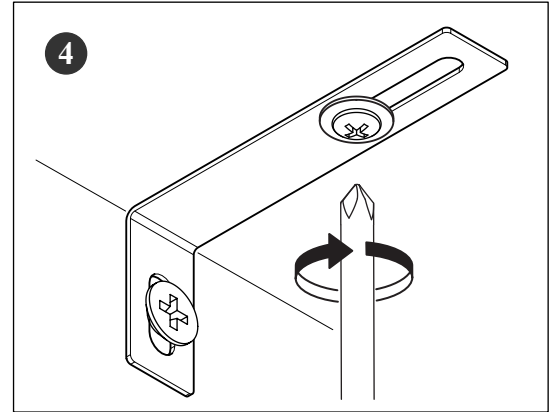
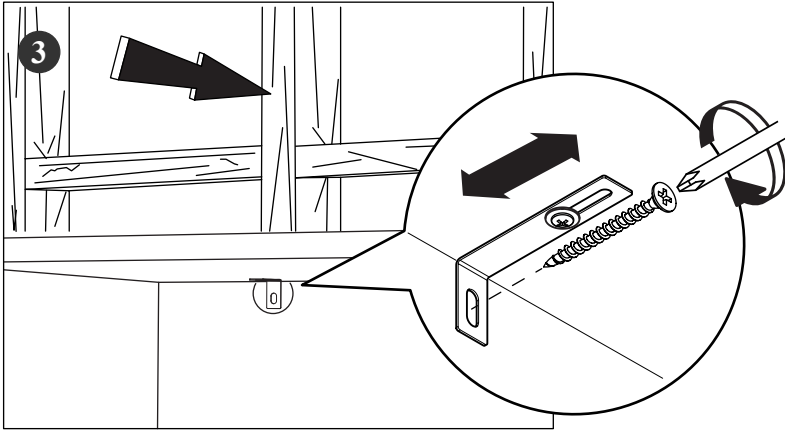
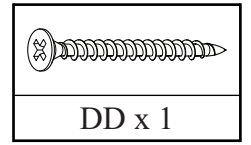
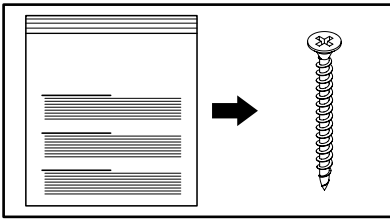

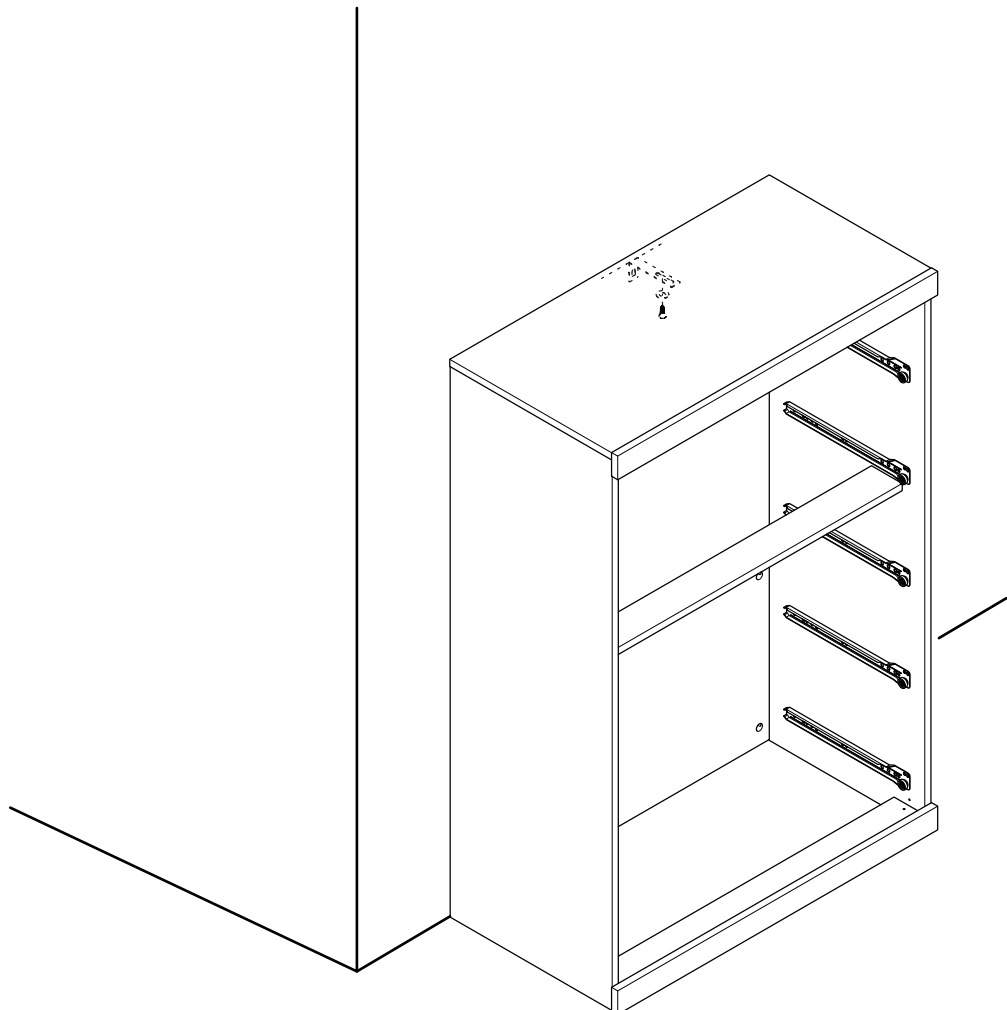

Screw the safety bracket to the wall stud:  
– Screw the safety bracket (AA) to the wall stud with Screw (DD)

Adjust the :  
– Tighten back the screw (CC) to secure the to be locked to the wall



# STEP 19

	
I x 20	B x 10

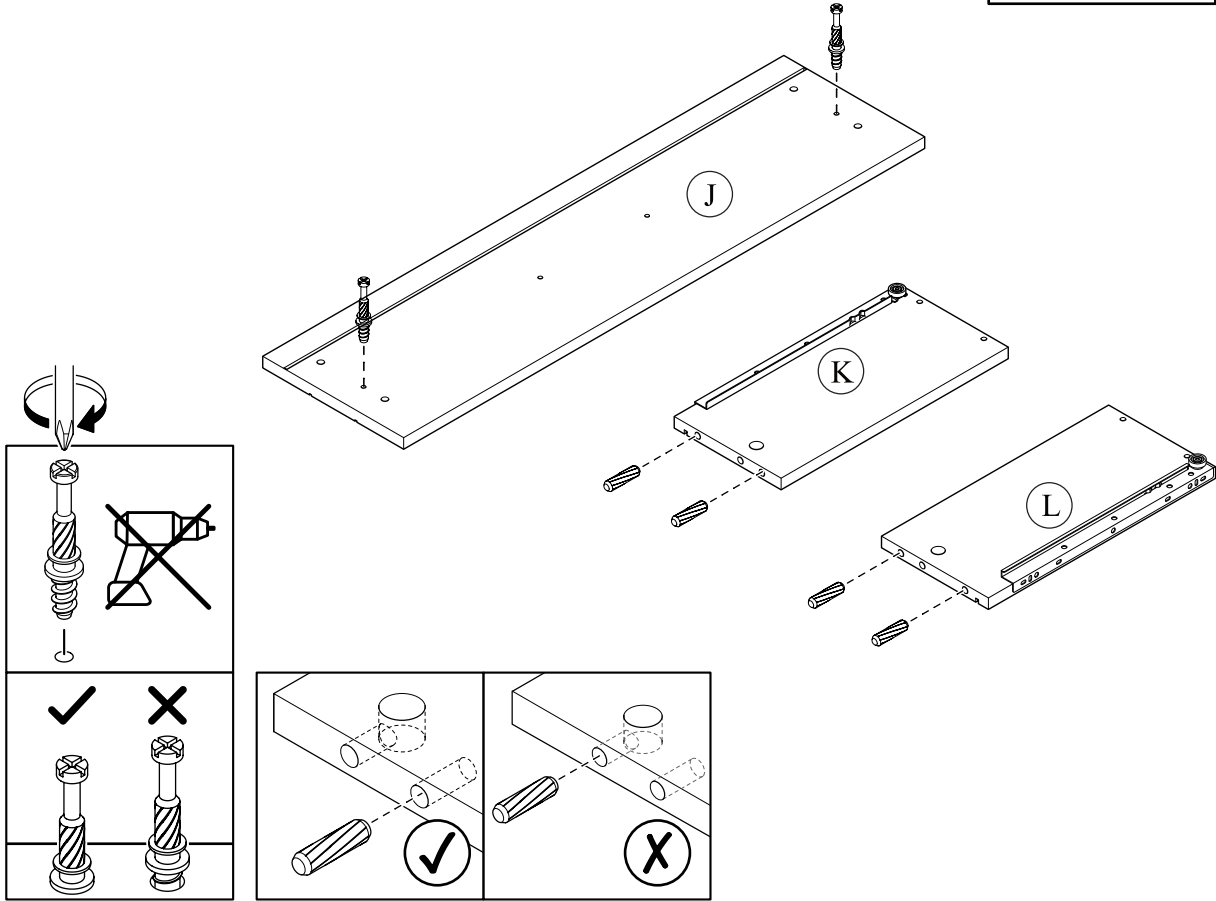

(5x)

# STEP 20

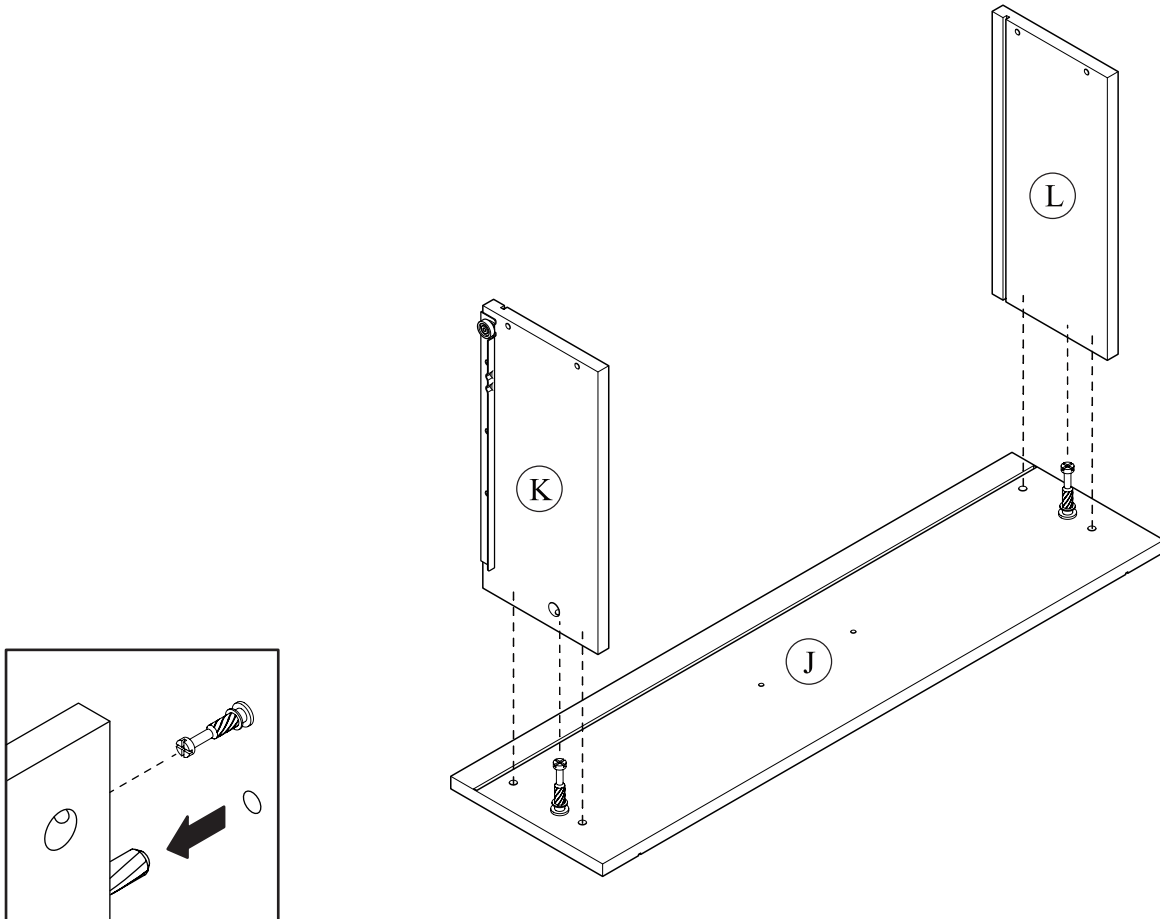

(5x)

# STEP 21

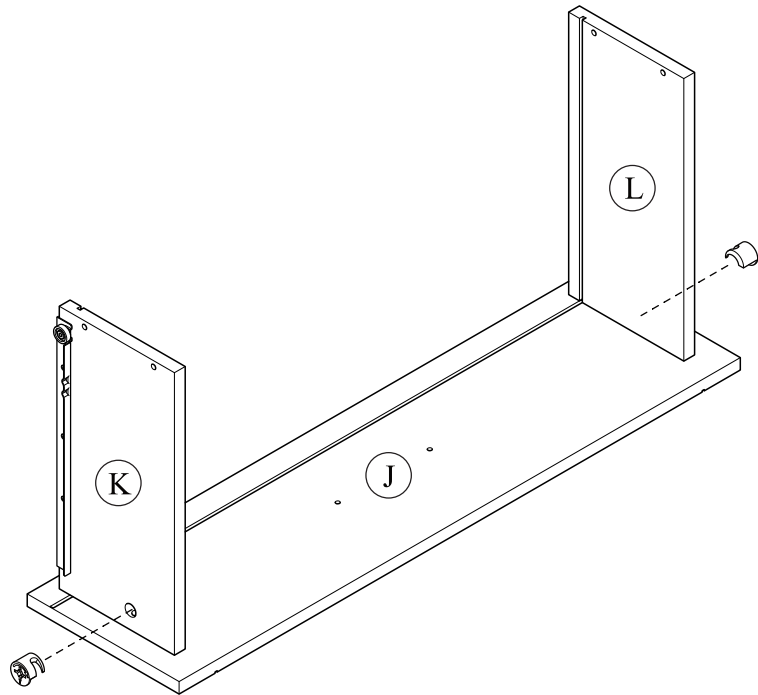
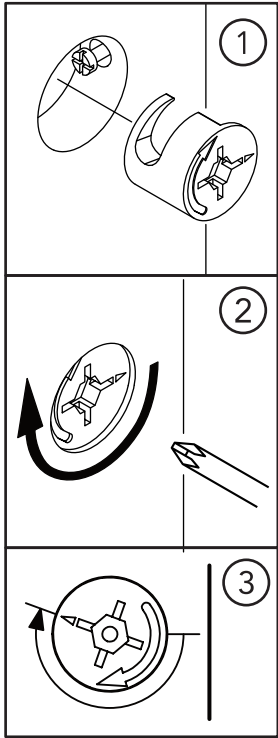
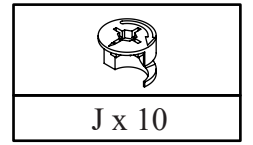

(5x)

# STEP 22

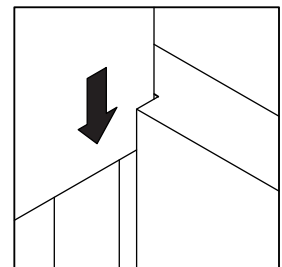
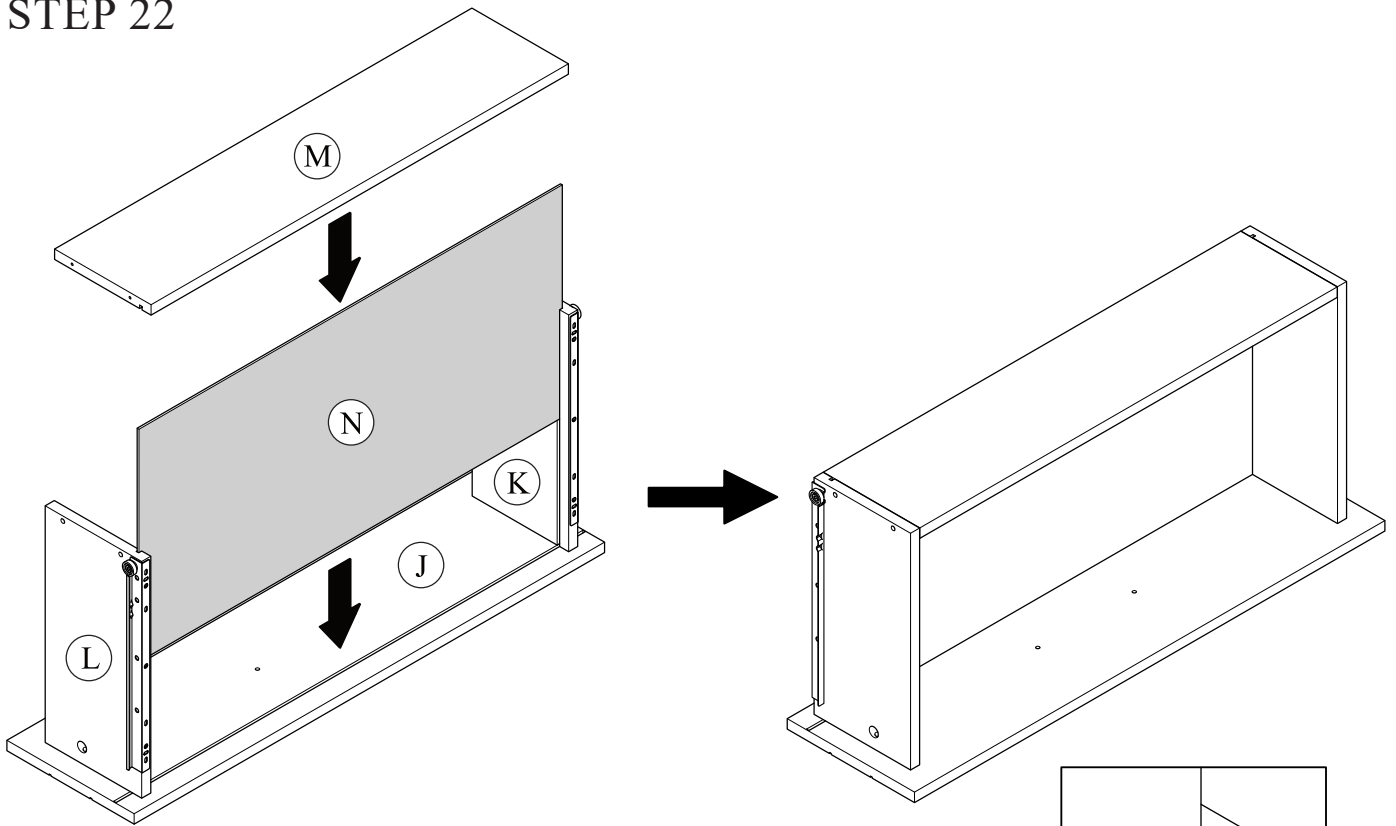

(5x)

# STEP 23

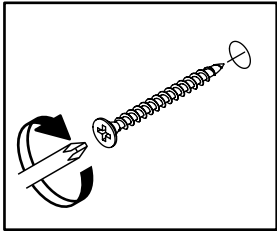
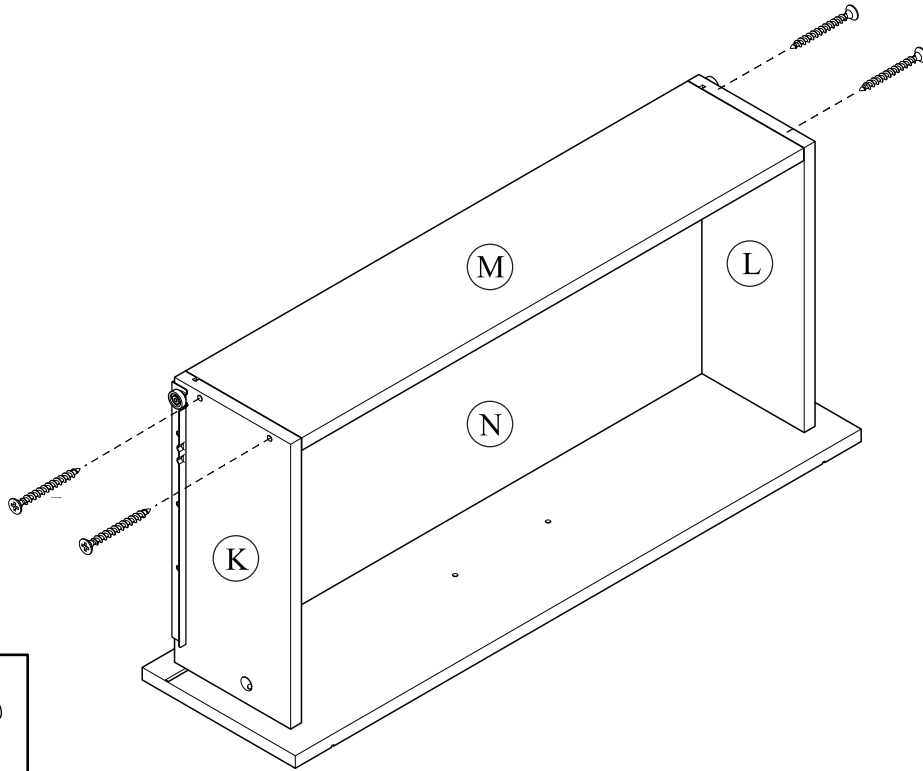
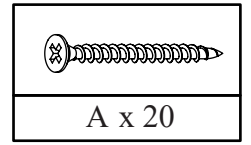

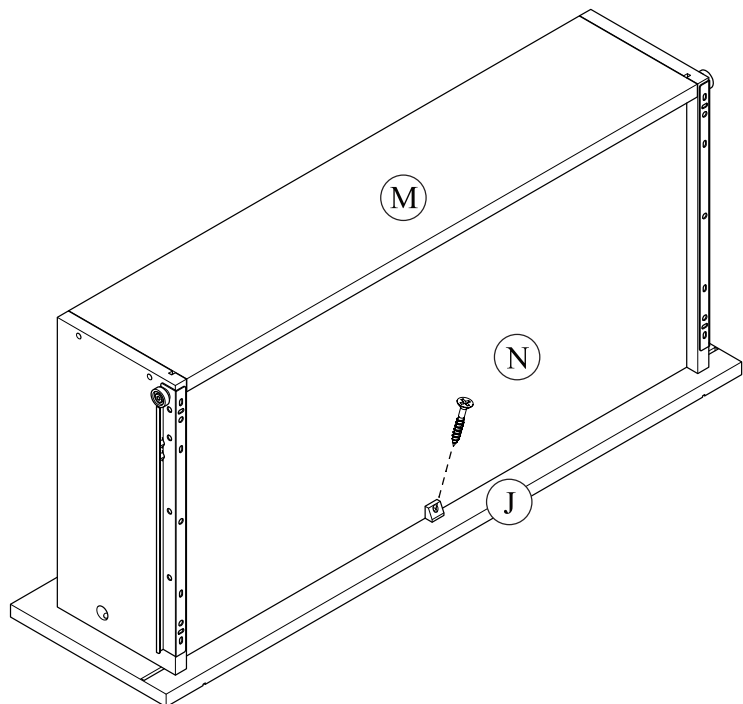
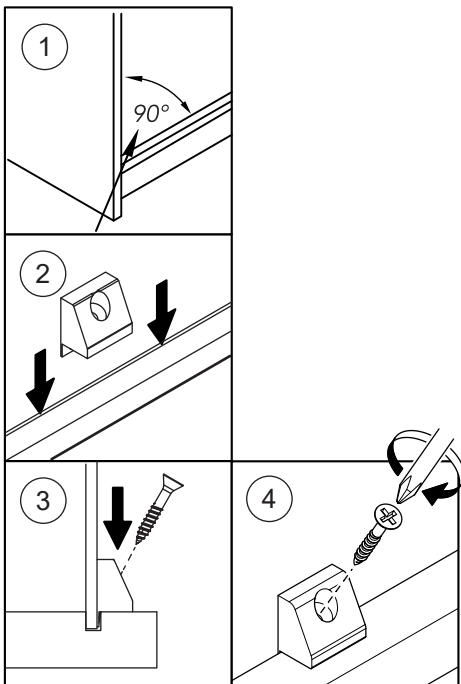
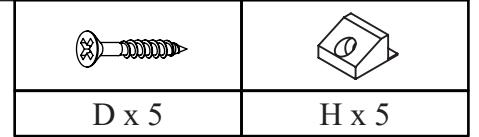

(5x)

# STEP 24

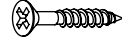

(5x)

# STEP 25

	
D x 5	H x 5

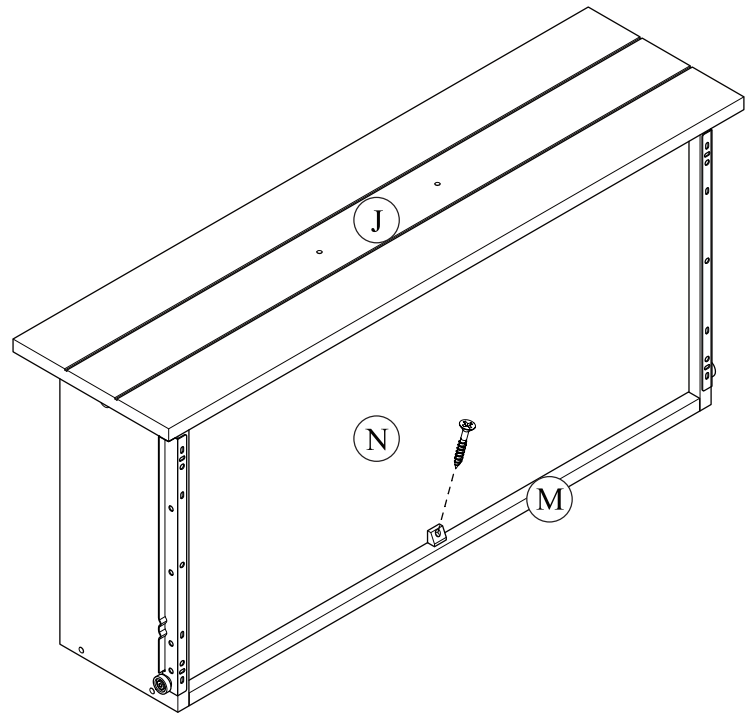
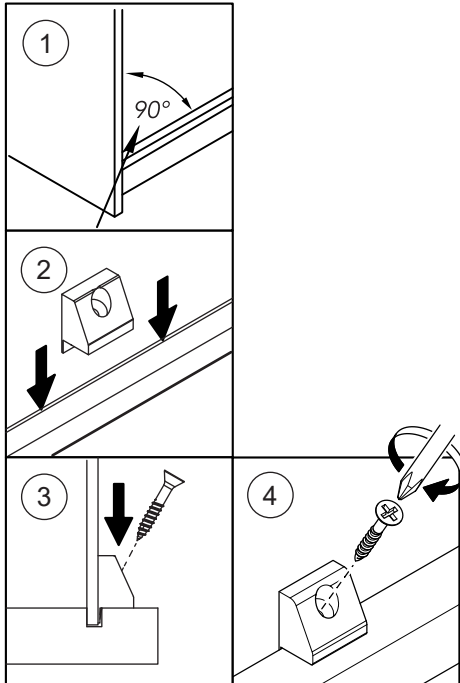

(5x)

# STEP 26

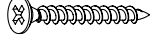
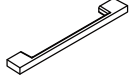
	
C x 10	G x 5

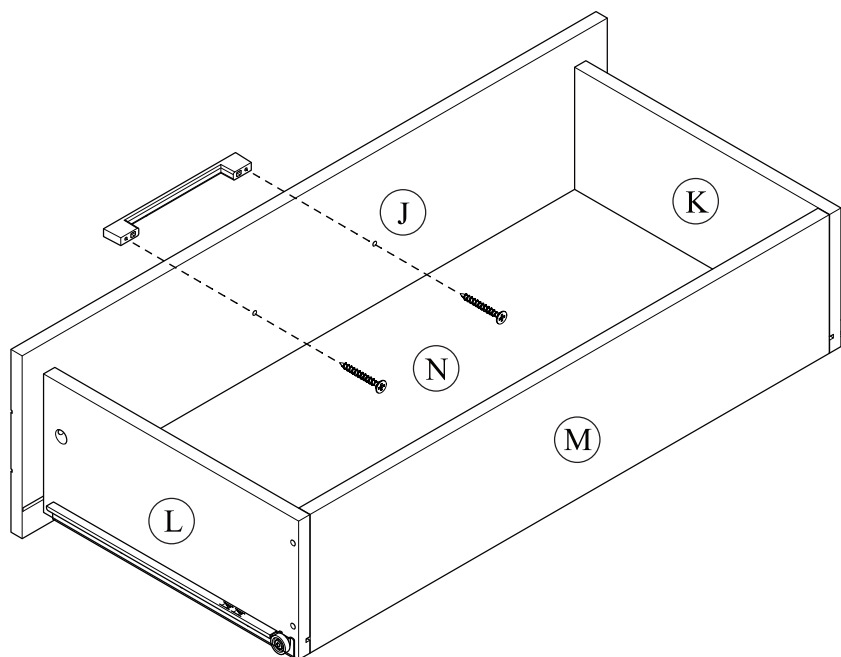
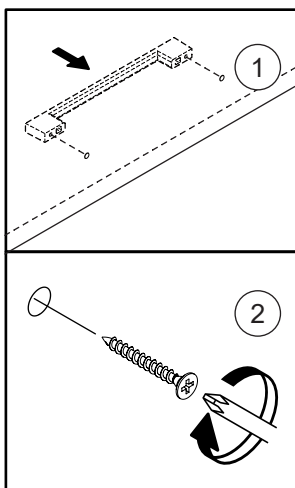

(5x)

# DRAWER INTERLOCK SYSTEM

## SYSTÈME DE VERROUILLAGE DES TIROIR

### SISTEMA DE INTERBLOQUEO DE CAJON

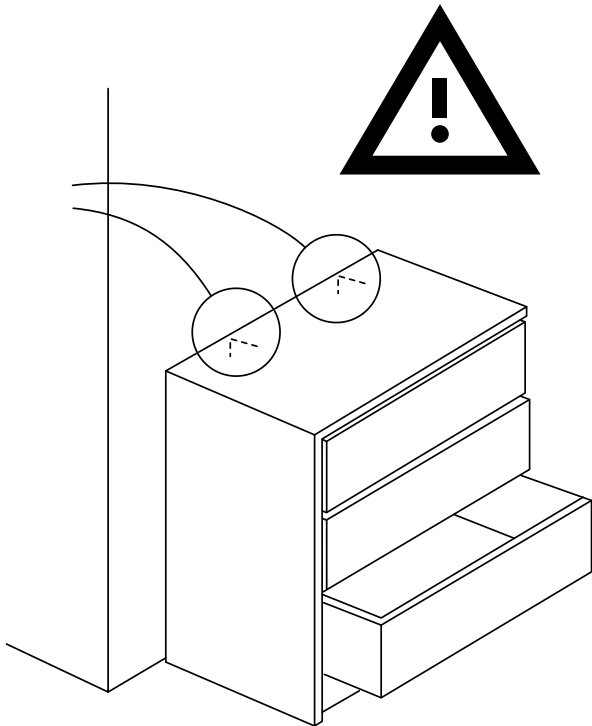

Never use the unit without the interlock system installed following the instructions

Ne jamais utiliser l'appareil sans le verrouillage installé en suivant les instructions

Nunca utilice la unidad sin el sistema de enclavamiento instalado siguiendo las instrucciones

This item features an interlock system that allows for the opening of only one drawer at a time, preventing the simultaneous opening of multiple drawer.

Cet article est doté d'un système de verrouillage qui permet l'ouverture d'un seul tiroir à la fois, empêchant l'ouverture simultanée de plusieurs tiroirs.

Este artículo cuenta con un sistema de bloqueo que permite la apertura de un solo cajón a la vez, evitando la apertura simultánea de varios cajones.

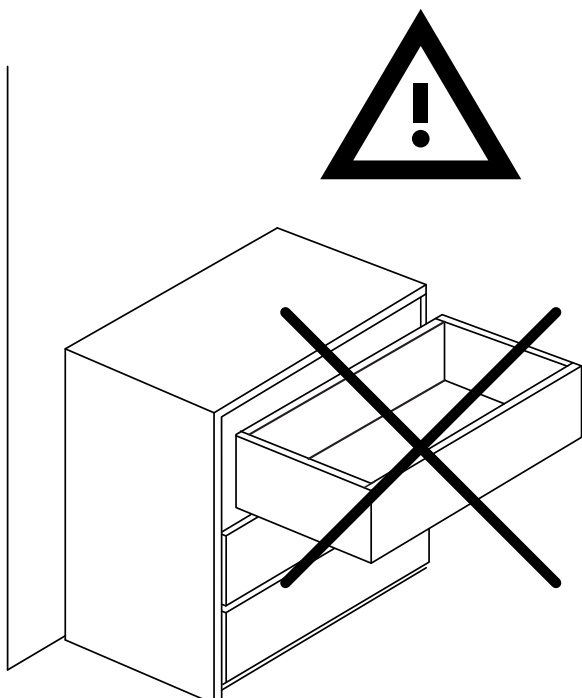

Do not defeat or remove the drawer interlock system. It is important stability and safety system.

Ne pas défaire ou retirer le système de verrouillage du tiroir; il s'agit d'un important système de stabilité et de sécurité.

No anule ni retire el sistema de bloqueo del cajón. Es importante el sistema de estabilidad y seguridad.

## STEP 27

Start by assembling the bottom most drawer first and work upwards.

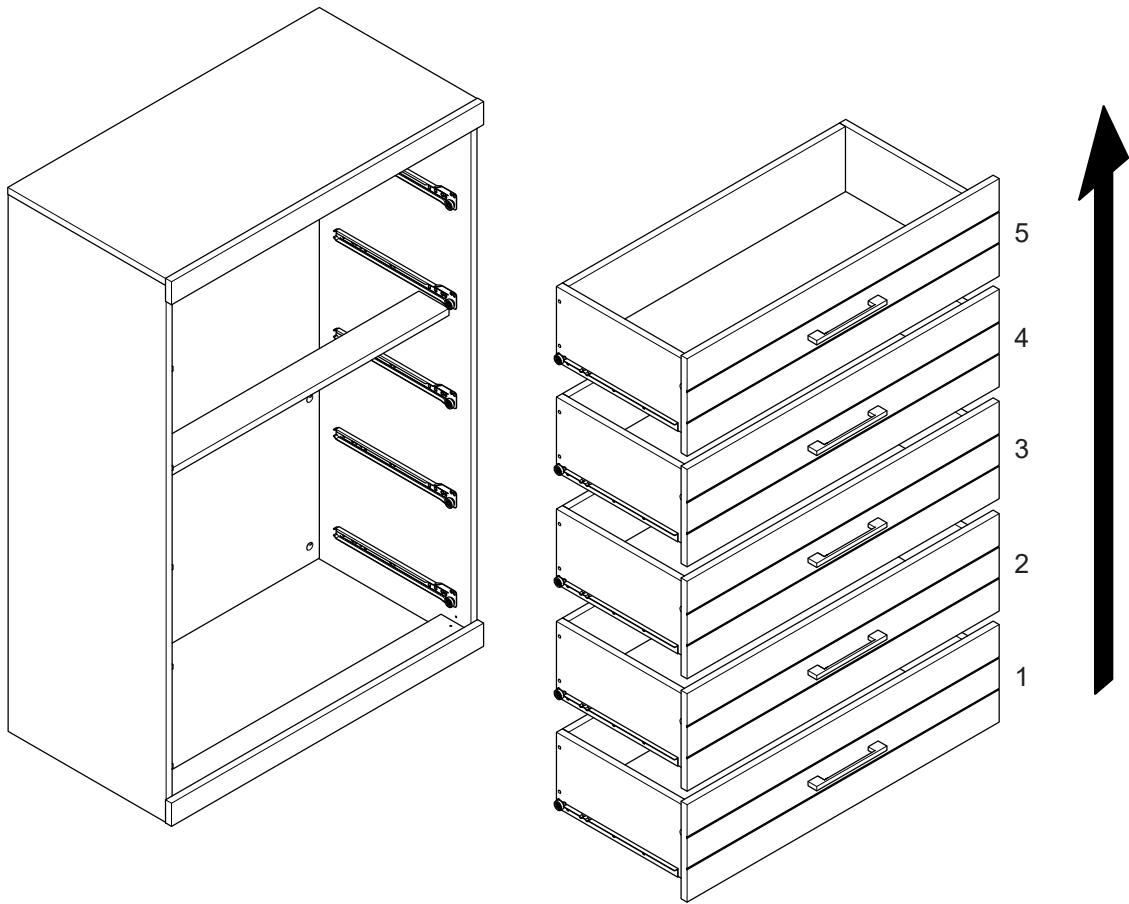

## STEP 28

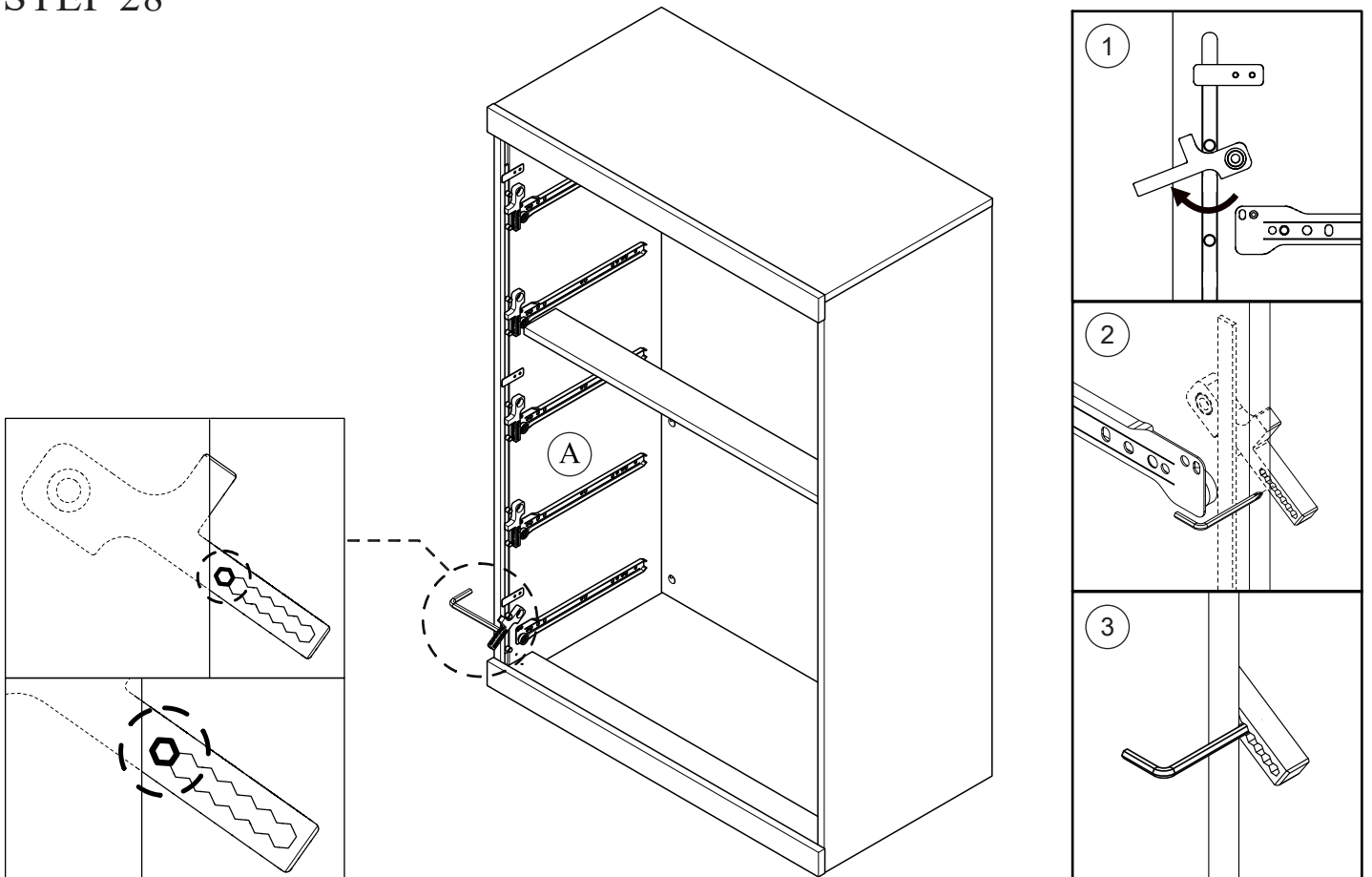

# STEP 29

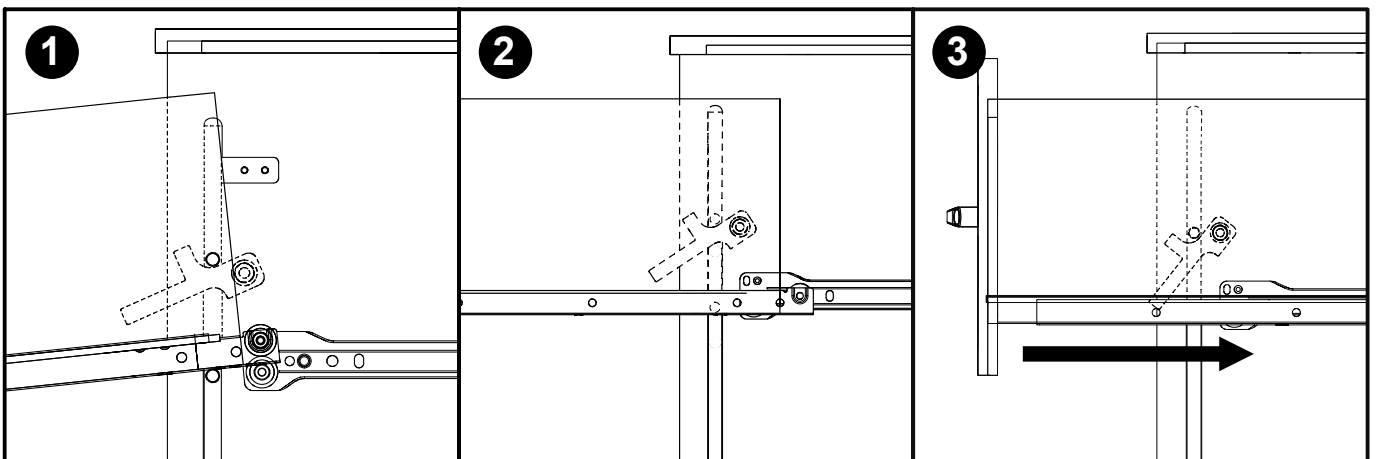
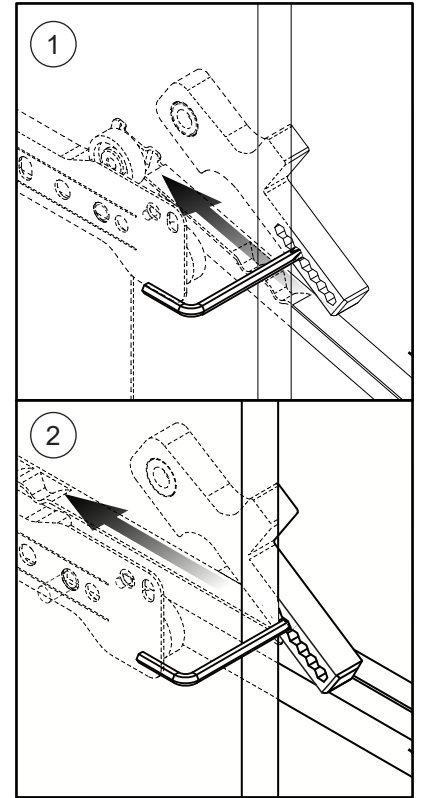
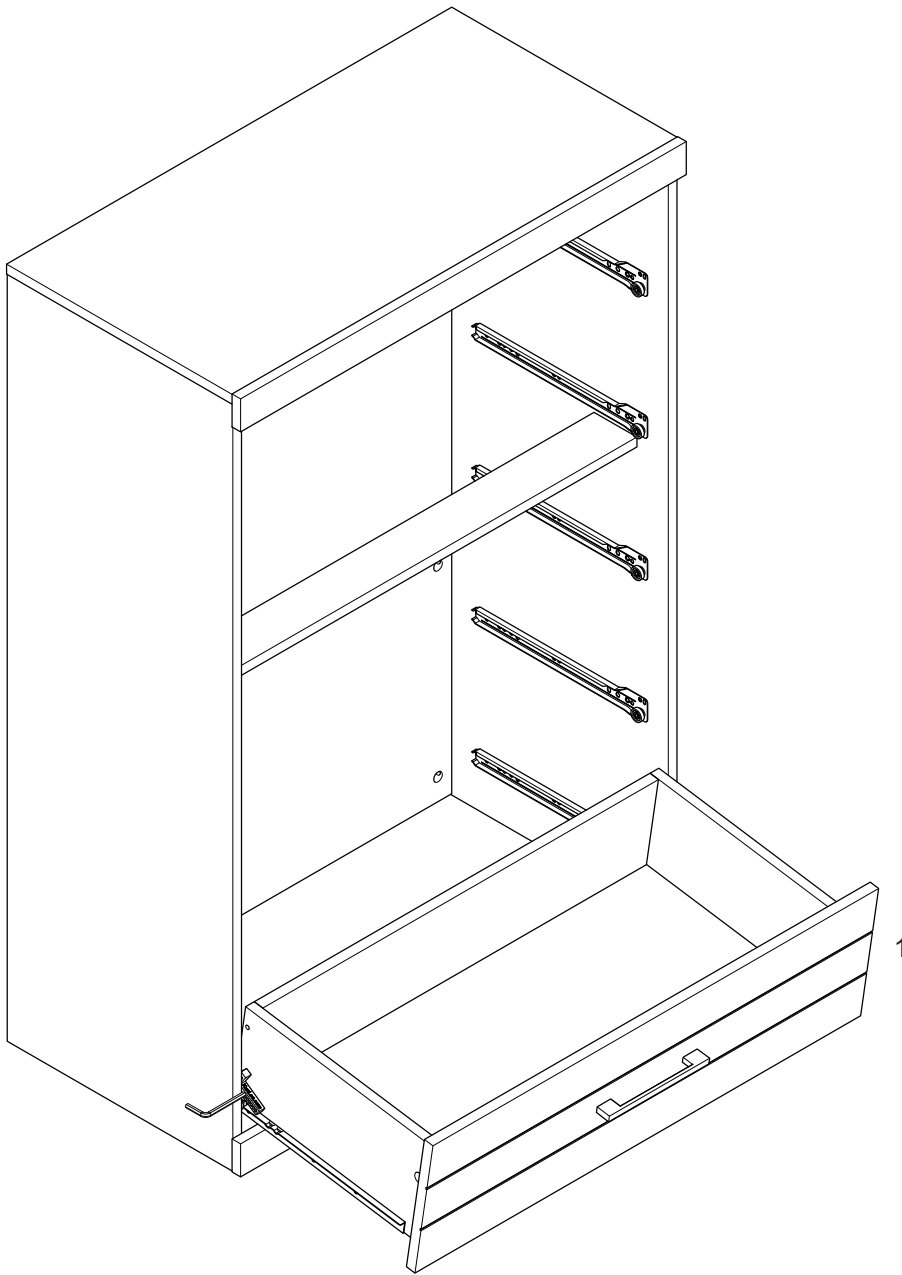

# STEP 30

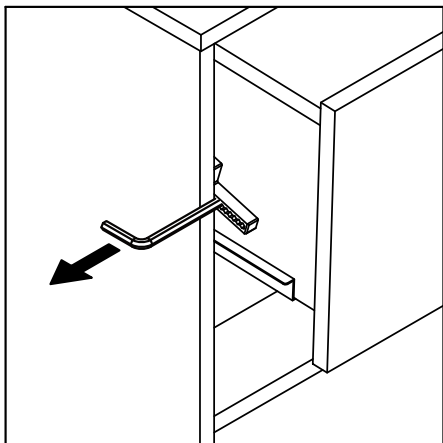
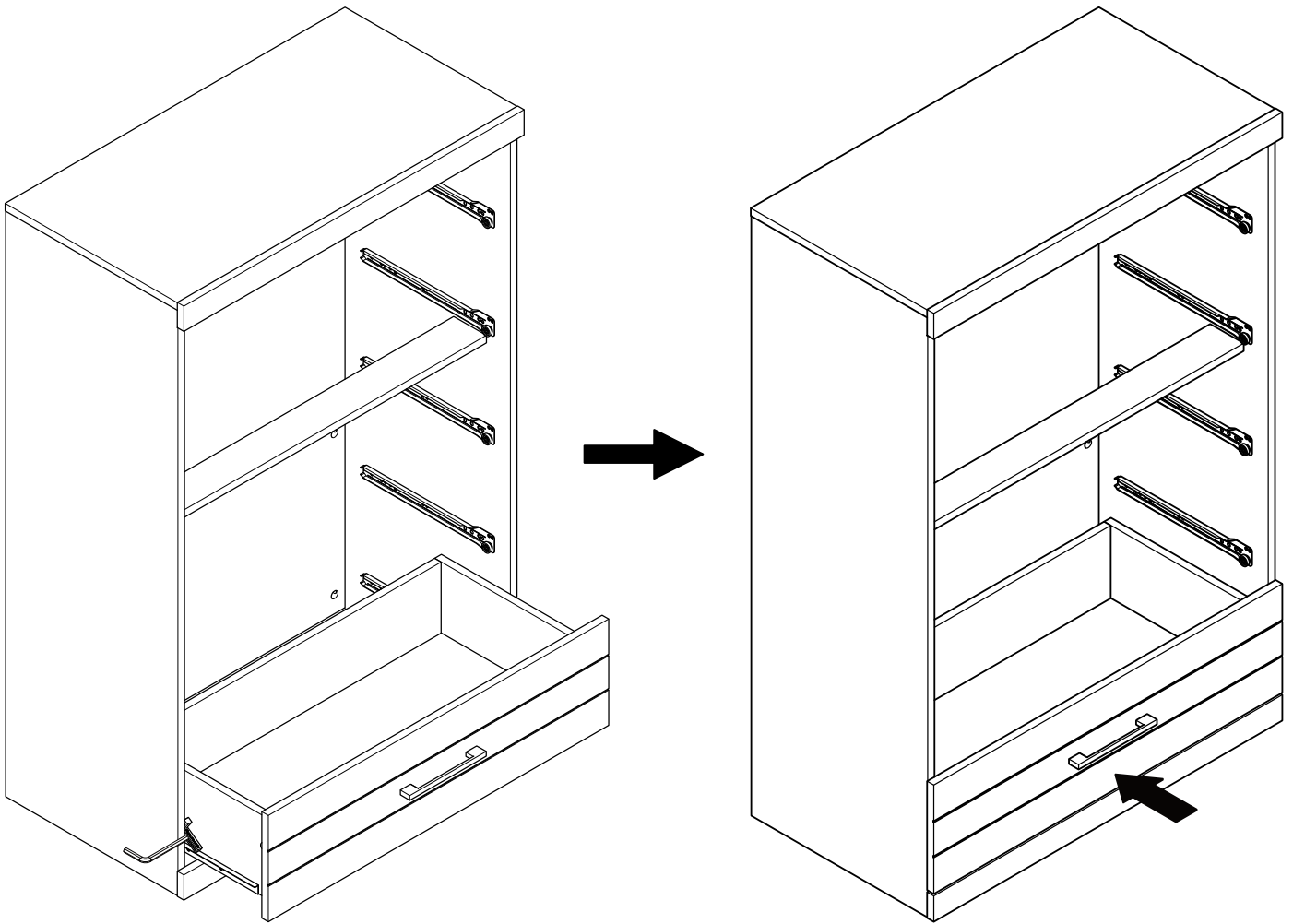

# STEP 31

Repeat step 27 to 29 for each of the remaining drawer.

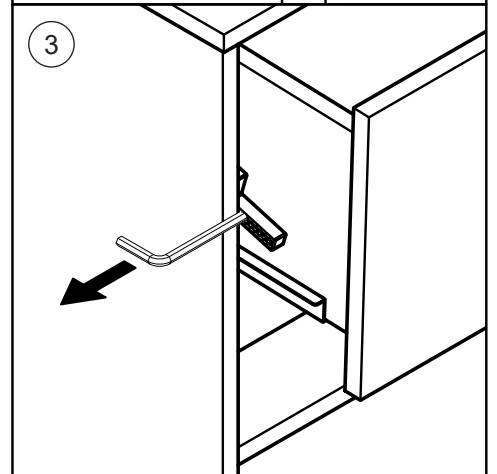
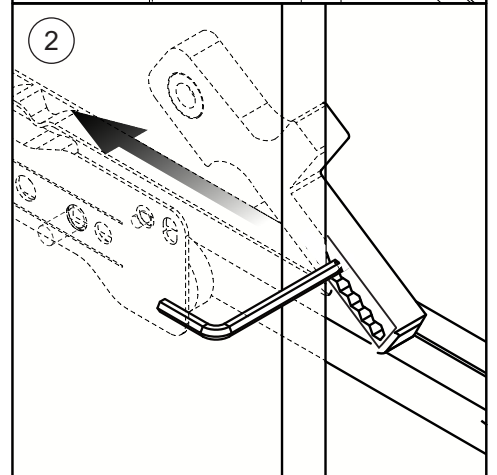
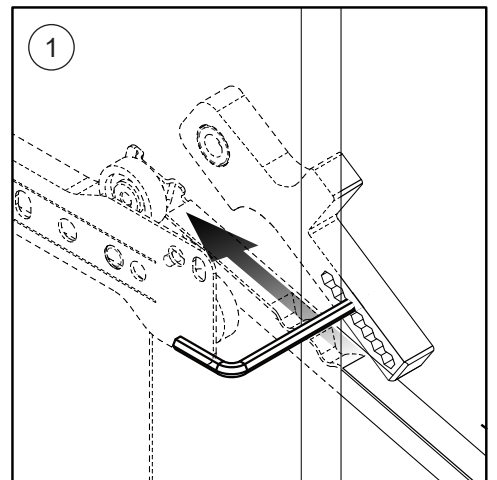
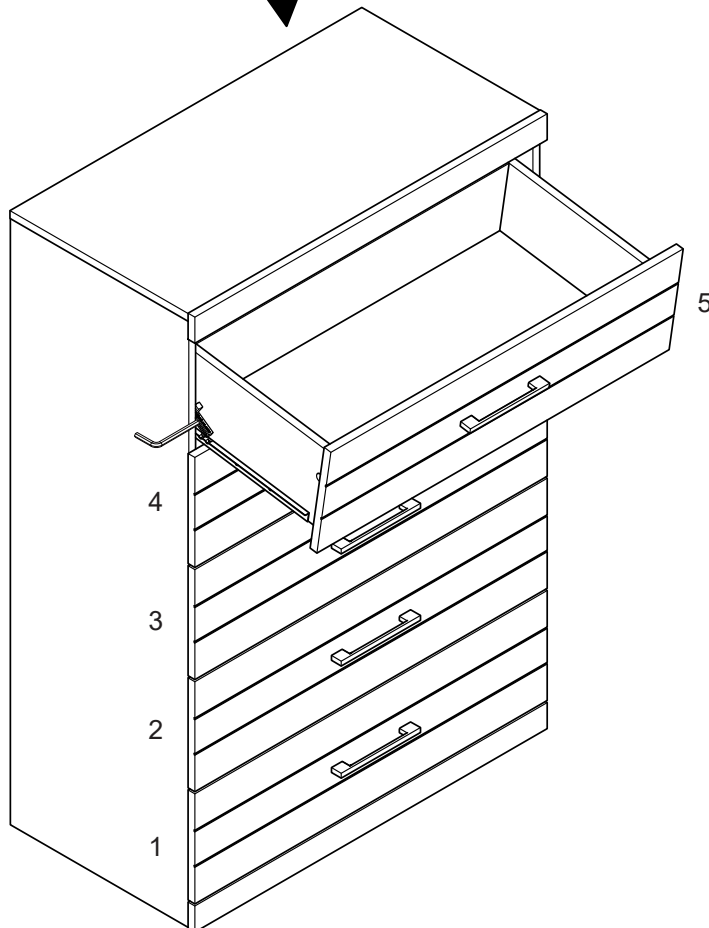
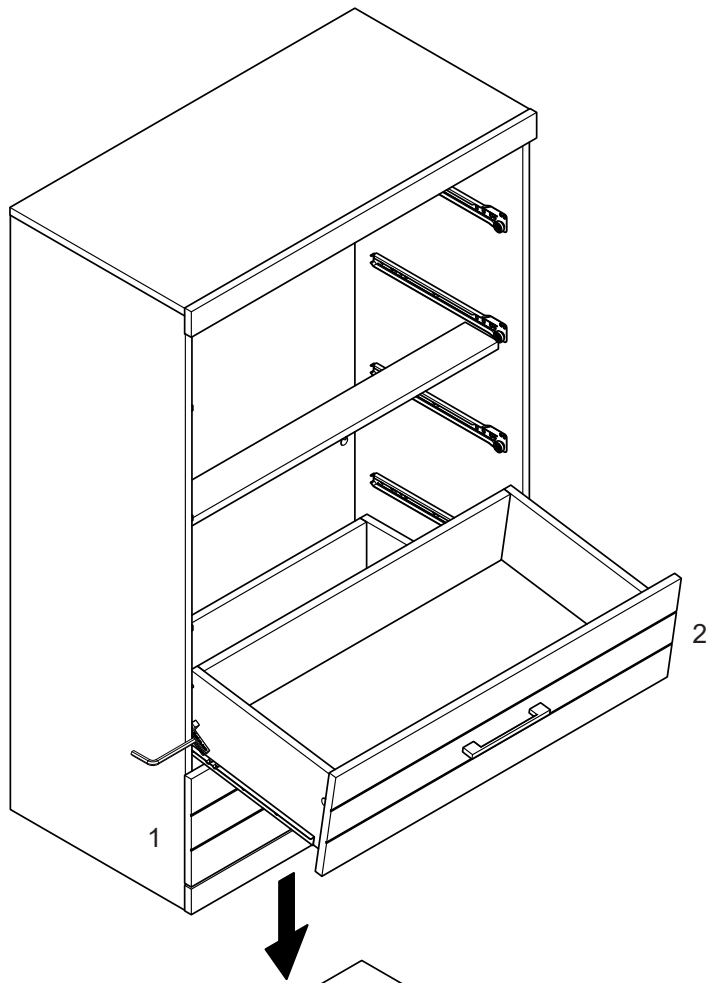

## MAXIMUM LOADS CHARGES MAXIMALES / CARGA MAXIMA

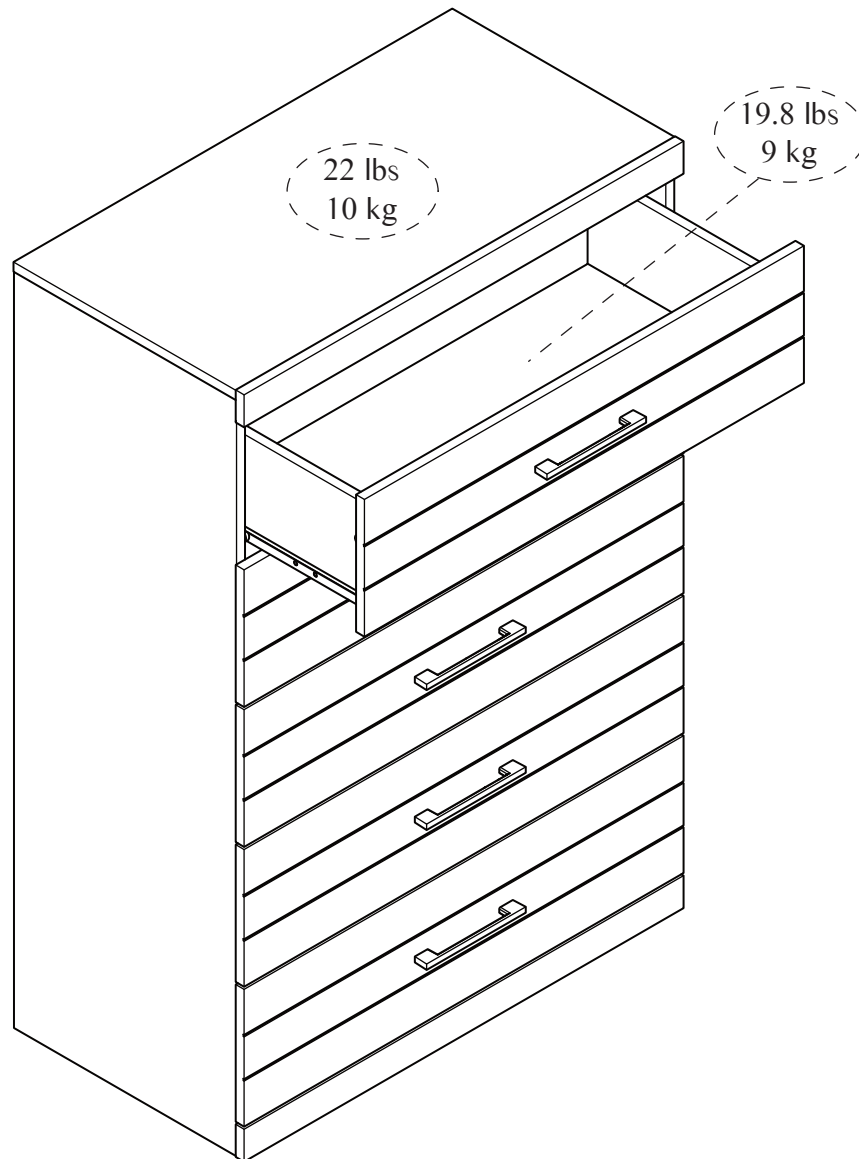

---

This product is designed to withstand the weight noted on the plan. We are not responsible for the breakage of parts or any injury caused by failure to comply with this recommendation.

---

Ce produit est conçu pour supporter le poids indiqué sur le plan. Nous ne sommes pas responsables de la casse de pièces ou toute blessure causée par le non-respect de cette recommandation.

---

Este producto está diseñado para soportar el peso indicado en el plano. No somos responsables de la rotura de piezas o cualquier lesión causada por el incumplimiento de esta recomendación.

---