

12 Pieces Cookware Set Instruction Manual

CJ-12T01-BG

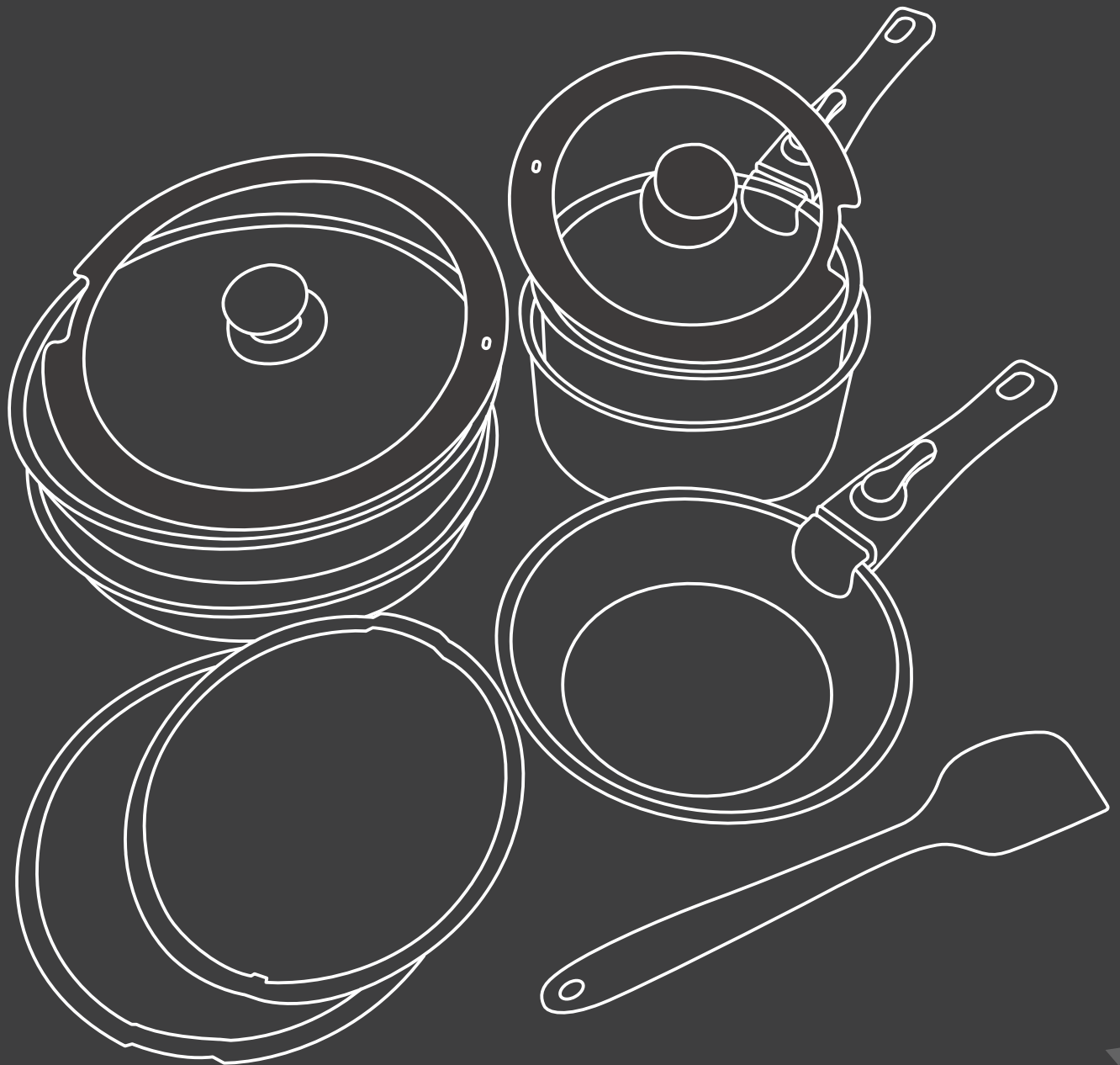

INSTRUCTIONS FOR ATTACHING AND DETACHING THE HANDLE

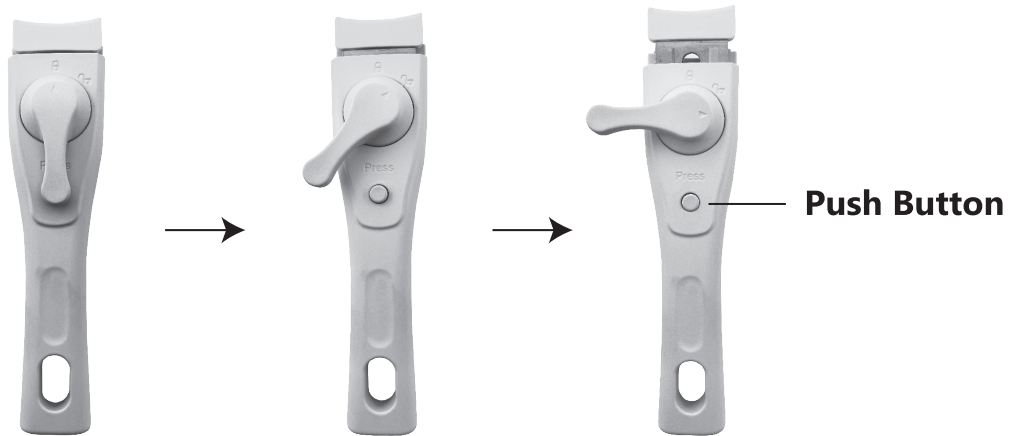

Turn the knob to "A" and press the "Press" button to extend the top of the handle.

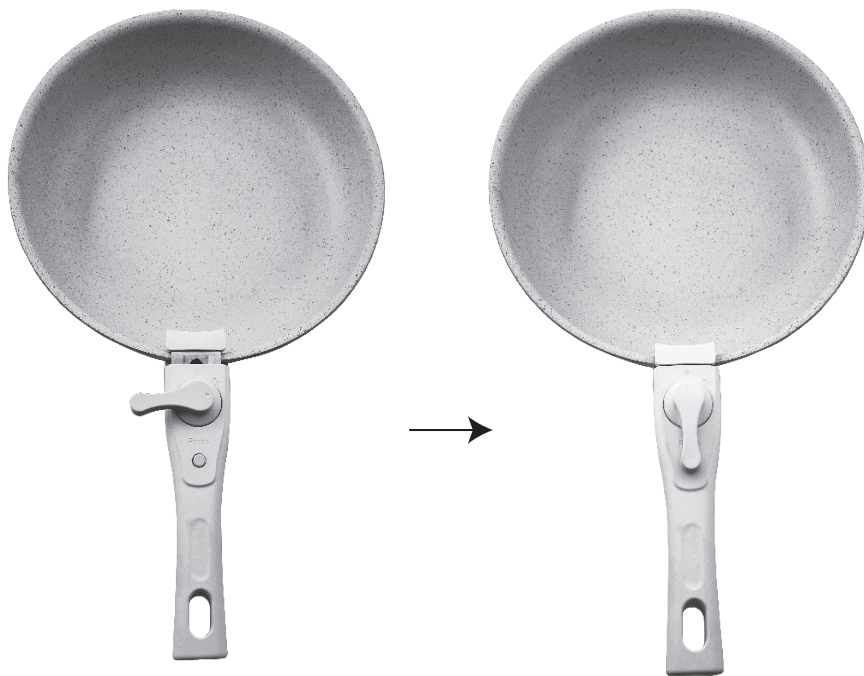

Clamp the top of the handle completely around the edge of the pan and turn the knob to point to "A" so you can safely use the handle.

IMPORTANT NOTICE

These operations must be performed on a flat, cool surface while holding the cooking item with one hand and the handle with the other. This handle is designed for use only within its specified range and is not suitable for use with all cooking items.

To prevent accidents, keep all cooking items out of the reach of children. Do not place the handles in the oven or dishwasher. When cleaning the handles, use a sponge or damp cloth to avoid soaking. For gas users, it is recommended that the proper size cooktop be used for each appliance.

Care and Use Instructions

Before first use:

Before using your cookware for the first time, remove all the packaging and wash in hot soapy water with a mild detergent and a soft cloth, dry thoroughly.

Before using your non-stick cookware for the first time it must be pre-conditioned to protect the non-stick surface: wipe inner surface of cookware with vegetable oil; heat gently: cool thoroughly and wipe clean with a soft cloth.

Using your new cookware:

To get the best from your cookware:



- Your cookware is suitable for use on gas, electric, solid hot plate, halogen, ceramic, radiant ring and, induction hobs. The maximum temperature of cookware should not exceed 250°C (482°F).
- Please remove the handle while the pot is heating.
- Your cookware is not suitable for deep fat frying, for use in a microwave oven, under the grill or on an open fire.
- To maintain the non-stick surface of your cookware do not dry fry food, always use a small amount of oil or fat.
- Do not use metal utensils with your cookware as these will damage the surface: use only heat resistant plastic silicone or wooden utensils.
- Do not cut food in your cookware as this will damage the surface.
- Avoid leaving foods with high salt content in your cookware as this may cause pitting.
- To avoid spillages or boiling over, do not fill your cookware more than two thirds of the capacity: once boiling point is reached, use the lowest heat setting possible for the food type.
- For optimum energy efficiency and even heat distribution do not place cookware on hob rings larger than the base size of your cookware or allow flames to overlap the sides of your cookware.
- For optimum energy efficiency and to avoid damaging your cookware, especially the non-stick coating, always use the lowest heat setting possible for the food type.
- Never leave your cookware unattended whilst in use and ensure your kitchen is well ventilated.
- Any screws present on the lid or handles of your cookware may loosen over time: using a screw driver, retighten the screws as necessary. Be cautious with screws on glass lids as over-tightening may result in your lid being damaged.

Cleaning your cookware:

- Allow your cookware to cool thoroughly before moving or cleaning.
- Do not pour cold water or liquids into your hot cookware as this may cause warping.
- To maintain the finish of your cookware it is recommended that you hand wash your cookware: clean your cookware in hot soapy water with a mild detergent and a soft cloth: do not use harsh or abrasive cleaners or scourers as this will damage the surface, rinse and dry thoroughly.
- To remove stubborn stains from your cookware use a non-abrasive plastic mesh or pad, with hot soapy water and a mild detergent.
- Do not leave your cookware to soak in water for long periods of time.
- Do not clean your cookware in a dishwasher as this will damage the surface.

Storage:

- Do not store wet cookware; store cookware in a dry, clean place.
- If stacking your cookware, place a layer of paper between your cookware to avoid scratching or damage.

Caution:

- Do not allow the handles of your cookware to overlap adjacent hob rings or the edge of your hob, which can result in injury or damage.
- The handles of your cookware may become hot during use: always use heat-resistant oven gloves to move your cookware.
- Do not allow your cookware to boil dry as this can cause warping.
- Never expose your hot cookware to cold water or liquids as this will damage the surface.
- If your cookware becomes over-heated allow to cool to room temperature before moving your cookware.
- If your cookware has been severely over-heated you must allow it to cool to room temperature before moving from the hob: examine the condition and safety of your cookware before using again; if there is any evidence of damage you must dispose of your cookware carefully.

Silicone Tool Set with Handle:

- Keep the silicone tool set away from direct heat or naked flames.
- The silicone tool set with handle is not suitable for dishwasher use.

