

# **Outdoor Freestanding Shower Faucet Installation Manual**

**W-102(ES)**

# Warranty Duration

All components of this faucet system are covered under a lifetime limited warranty, ensuring they are free from defects in material and workmanship for the original purchaser.

# Repair and Replacement

If the product shows defects in material or workmanship under normal use and within the warranty period, we will, at our discretion, either repair the product or provide a replacement at no cost to the original purchaser. Please note that proof of purchase (e.g., an invoice) is required when requesting service. The warranty does not cover damages caused by improper installation, misuse, or modifications.

# Exclusions

We shall not be responsible for the following cases:

- Damage to the product caused by improper installation, misuse, unauthorized repair or replacement, or abuse (including damage during shipment).
- Damage to the product caused by improper dismantling after installation.
- Damage resulting from abnormal water pressure or impurities in water pipes, which is not covered under this warranty.
- Rust on the product due to insufficient care and maintenance, which is not covered under this warranty.
- Damage caused by natural disasters such as fire, flood, earthquake, lightning storms, etc., which is not covered under this warranty.

I hope this helps! If you have any further questions or concerns, please let me know.

# Having Trouble? Contact us.

 Email: [info@faucetsupport.com](mailto:info@faucetsupport.com)

 Toll Free: 1-888-969-6880



**M7059**  
**SFS-1188**

## **CONTENT**

**1. Outdoor Freestanding Shower Faucet Installation Instructions ----- (1-10)**

## **CONTENIDO**

**1. Instrucciones de instalación del grifo de ducha independiente para exteriores ----- (11-20)**

## ◆ Installation and Maintenance Matters

1. Check the accessories list to verify that all parts are complete in this package.
2. Do not disassemble the main body by yourself.
3. Connect inlet pipes to supply valves.
4. Make sure inlet pipes and supply valves have no impurities and are cleaned, with no impurities in the pipeline.
5. After installation, check all joints for leakages.
6. Do not leave the rain shower system exposed to a severely corrosive environment.

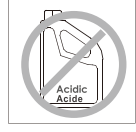
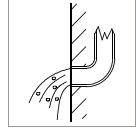
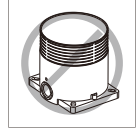
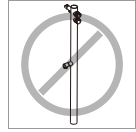

### Do's

1. In order to keep the mixer surface bright, please clean the mixer regularly.
2. Rinse the faucet with clean water and wipe it with a soft cotton cloth.
3. Use one of the following cleaners to remove dirt from the surface: a. Mild liquid cleaner. b. Colorless glass cleaner and powder cleaner that do not cause abrasion and can be dissolved completely. c. Polish liquid that does not cause abrasion.

### Don'ts

- a. Avoid using cleaning powder, harsh cleaning chemicals, brushes and coarse cloth to prevent scratching and friction.
- b. Do not use acid cleaners to clean the faucet as they may cause surface corrosion of the faucet. If the faucet is exposed to harmful acid substances, please rinse it immediately with water.

### Tools Needed:

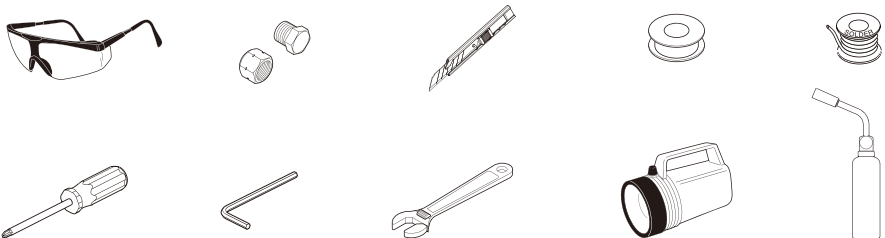

◆ **Outdoor Freestanding Shower Faucet Accessories List**

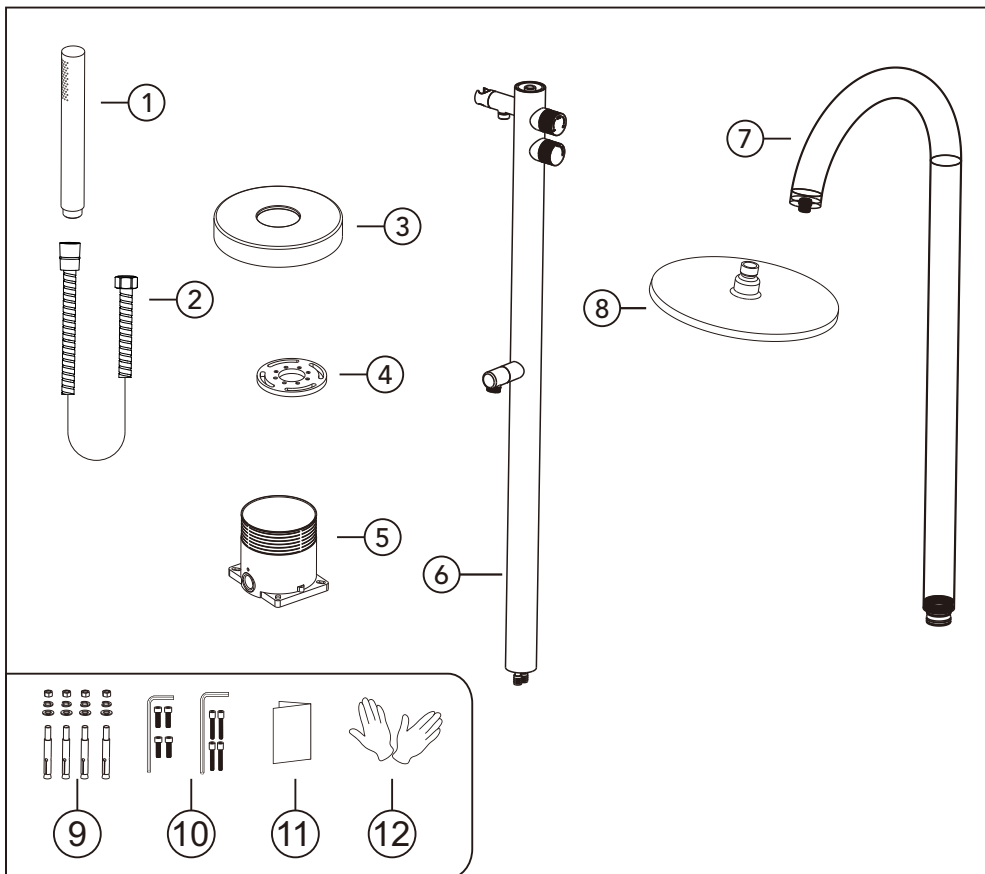

No.	Part name	Qty	No.	Part name	Qty
1	Hand shower	1	7	Shower tube	1
2	Shower hose	1	8	Shower head	1
3	Decorative cover	1	9	Concealed body parts	1set
4	Mounting plate	1	10	Mounting plate parts	2set
5	Concealed body	1	11	Instruction manual	1
6	Main body	1	12	Gloves	1pair

## ◆ Concealed Body Installation Depth

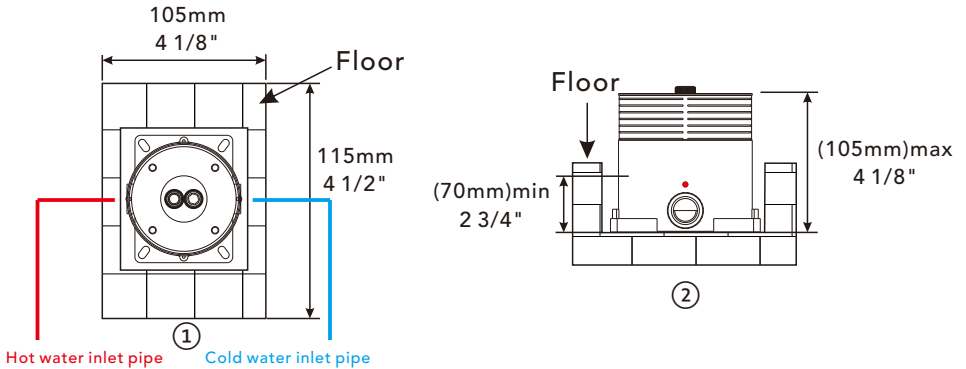

- Notice:** 1. The opening dimensions on the room floor, including length and width, are shown in diagram ①. The installation depth of the embedded body is shown in diagram ②.  
2. The dimensions must be between 70 mm (2 3/4") and 105mm (4 1/8").

Please connect the hot and cold water supply pipes according to the red and blue markings on the concealed body.

The red mark indicates the hot water inlet, and the blue mark indicates the cold water inlet.

---

## ◆ Concealed Body Installation Dimensions

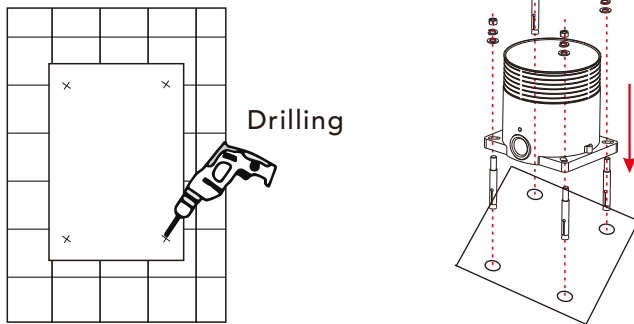

1. Place the concealed body at the center of the prepared hole, mark the positions of the four corresponding screw holes, and use a punch to drill the holes.
  2. Insert the expansion screws into the holes (ensure an appropriate screw length is exposed for securing the main body and nut).
  3. Then align the screw holes of the concealed body with the screws, and finally tighten the nut and washer.
-

## ◆ Installation Steps

### Step 1

After installing the concealed body, unscrew the top cover and trim off any excess part of the concealed housing.

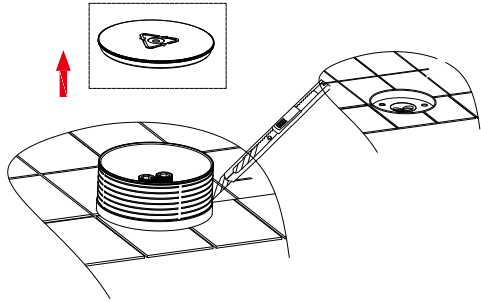

### Step 2

1. Loosen the screws on the mounting plate inside the concealed body and remove the mounting plate for later use.  
Use a hex wrench to remove the plastic expansion plugs; they do not need to be retained.

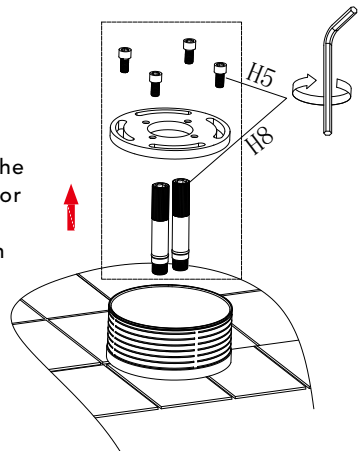

## ◆ Installation Steps

### Step 3

First, install the decorative cover onto the lower section of the straight pipe. Then, use a hex key to fasten the flange plate to the straight pipe with the screw.

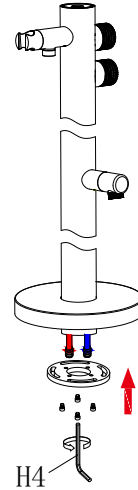

### Step 4

Insert the water inlet pipe into the corresponding holes of the concealed box. Adjust the position of the water outlet and the basin, and then connect the flange plate to the concealed box body using the flange plate screws.

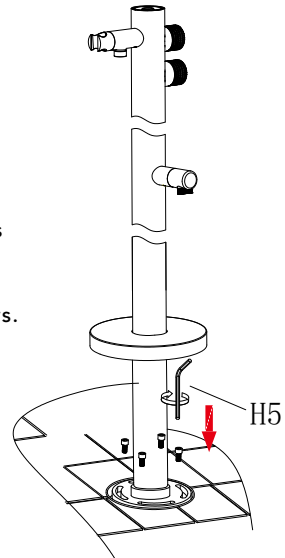

## ◆ Installation Steps

### Step 5

Screw the shower head into the spout in a clockwise direction.

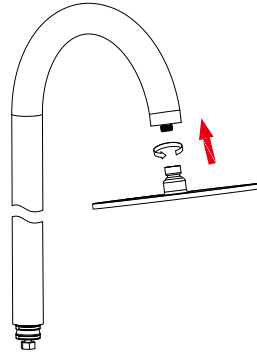

### Step 6

Insert the spout into the main unit and secure it by tightening the side screw.

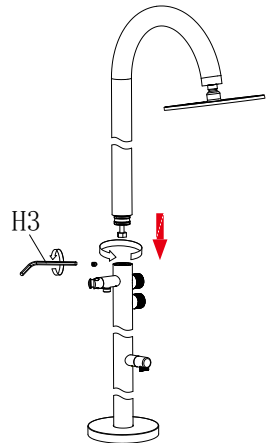

### Step 7

Connect the shower hose to both the main body and the hand shower.

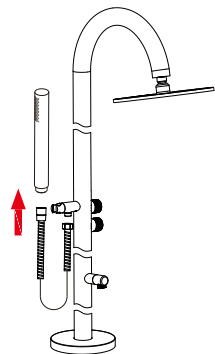

## ◆ Function Instructions

1. Water Outlet Function Switching:  
Rotate the upper handle to switch between water outlet functions.
2. Hot and Cold Water Adjustment:  
Turn the handle clockwise to start water flow; the temperature changes gradually from cold to hot.

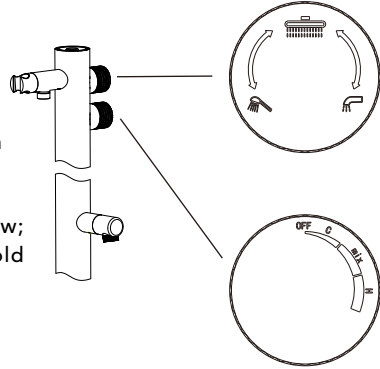

## ◆ Instalación y cuestiones de mantenimiento

1. Verifique la lista de accesorios para comprobar que todas las partes están completas en este paquete.
2. No desmonte el cuerpo principal por sí mismo.
3. Conecte las tuberías de entrada a las válvulas de suministro.
4. Asegúrese de que las tuberías de entrada y las válvulas de suministro no tengan impurezas y estén limpias, sin impurezas en la tubería.
5. Después de la instalación, verifique todas las uniones para detectar fugas.
6. No deje el grifo para lavabo expuesto a un entorno altamente corrosivo.

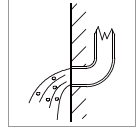
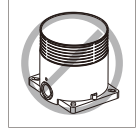
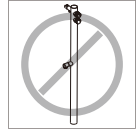

### Hacer

1. En para mantener la superficie de la batidora brillante, limpie el mezclador regularmente.
2. Inse el grifo con agua limpia y límpielo con un suave ropa de algodón.
3. Utilice uno de los siguientes limpiadores para eliminar la suciedad de la superficie: a. Limpiador líquido suave. b. Limpiador de vidrio incoloro y limpiador en polvo que no causen abrasión y que se puedan disolver completamente. c. Líquido pulidor que no cause abrasión.

### No es decir

- A. Valte con polvo de limpieza, productos químicos de limpieza duros, cepillos y tela gruesa para evitar rascar y fricción.
- B. No use limpiadores de ácidos para limpiar el grifo, ya que pueden causar corrosión superficial del grifo. Si el grifo está expuesto a sustancias ácidas dañinas, enjuague inmediatamente con agua.

## HERRAMIENTAS NECESARIAS:

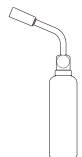
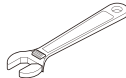
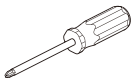

◆ Grifo de ducha independiente para exteriores

Lista de Accesorios

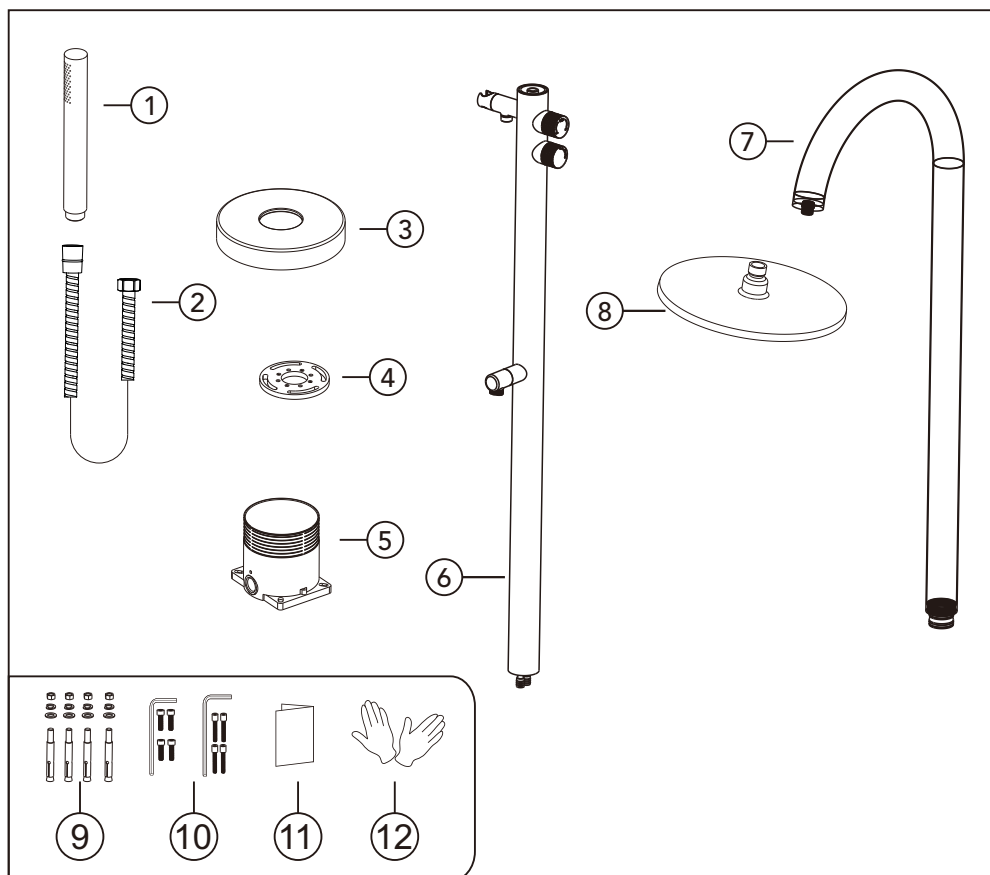

N.º	Nombre de la pieza	Cant.	N.º	Nombre de la pieza	Cant.
1	Ducha de mano	1	7	Tubo de ducha	1
2	Manguera de ducha	1	8	Cabezal de ducha	1
3	Cubierta decorativa	1	9	Piezas del cuerpo empotrado	1 juego
4	Placa de montaje	1	10	Piezas de la placa de montaje	2 juego
5	Cuerpo empotrado	1	11	Manual de instrucciones	1
6	Cuerpo principal	1	12	Guantes	1 juego

## ◆ Profundidad de Instalación del Cuerpo Empotrado

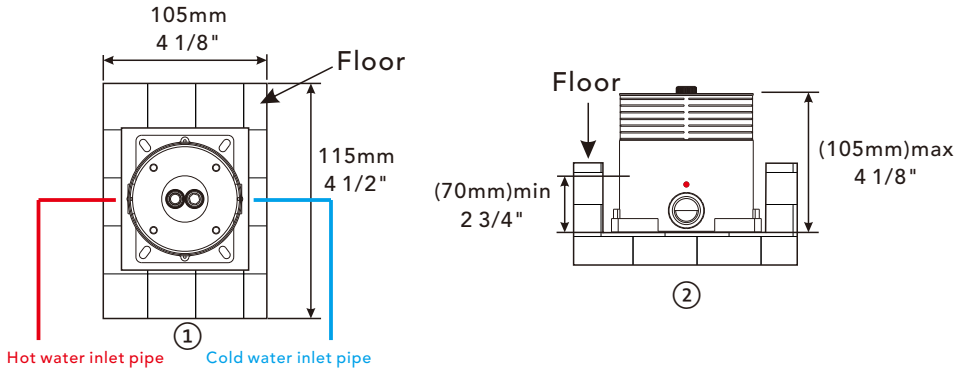

**Aviso:** 1. Las dimensiones de la apertura en el suelo de la habitación, incluyendo el largo y el ancho, se muestran en el diagrama ①. La profundidad de instalación del cuerpo empotrado se muestra en el diagrama ②.

2. Las dimensiones deben estar entre 70 mm (2 3/4") y 105 mm (4 1/8").

Conecte las tuberías de suministro de agua caliente y fría de acuerdo con las marcas rojas y azules en el cuerpo empotrado.

La marca roja indica la entrada de agua caliente y la marca azul indica la entrada de agua fría.

## ◆ Dimensiones de Instalación del Cuerpo Empotrado

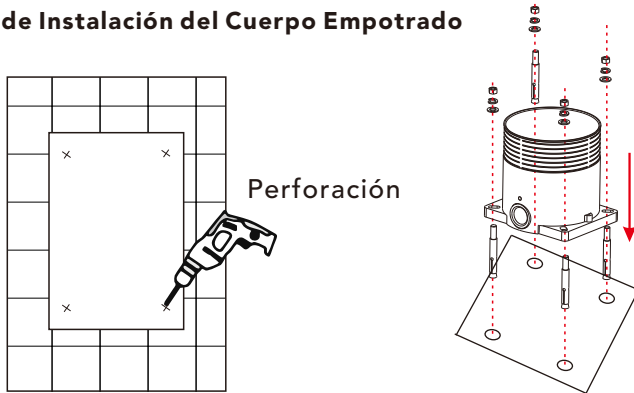

1. Coloque el cuerpo empotrado en el centro del orificio preparado, marque la posición de los cuatro orificios correspondientes para los tornillos y utilice un punzón para perforarlos.
2. Inserte los tornillos de expansión en los orificios (asegúrese de que quede expuesta una longitud adecuada del tornillo para fijar el cuerpo principal y la tuerca).
3. Luego alinee los orificios del cuerpo empotrado con los tornillos y, finalmente, apriete la tuerca y la arandela.

## ◆ Pasos de Instalación

### Paso 1

Después de instalar el cuerpo empotrado, desenrosque la tapa superior y recorte cualquier parte sobrante de la carcasa empotrada.

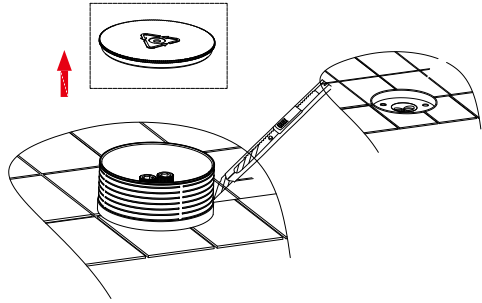

### Paso 2

1. Afloje los tornillos de la placa de montaje dentro del cuerpo empotrado y retire la placa de montaje para usarla más adelante. Use a hex wrench to remove the plastic expansion.
2. plugs; they do not need to be retained.

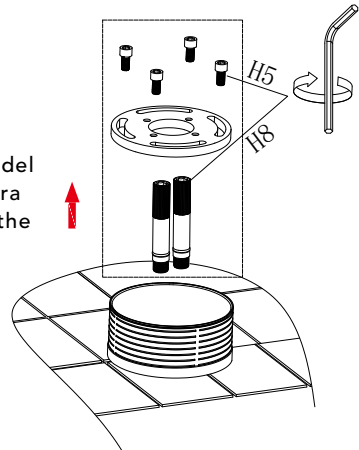

## ◆ Pasos de Instalación

### Paso 3

Primero, instale la cubierta decorativa en la parte inferior del tubo recto. Luego, use una llave hexagonal para fijar la placa de la brida al tubo recto con el tornillo.

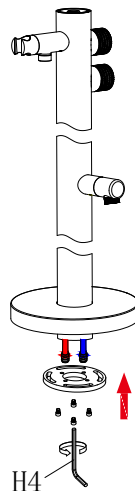

### Paso 4

Inserte la tubería de entrada de agua en los orificios correspondientes de la caja empotrada. Ajuste la posición de la salida de agua y del lavabo, y luego conecte la placa de la brida al cuerpo de la caja empotrada utilizando los tornillos de la placa de la brida.

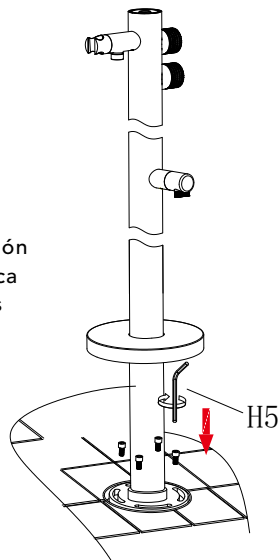

## ◆ Pasos de Instalación

### Paso 5

Atornille el cabezal de ducha en el pico en dirección horaria.

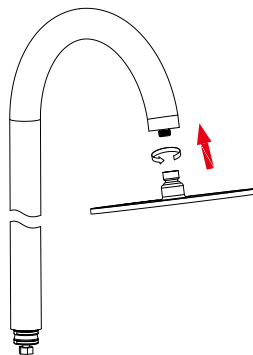

### Paso 6

Inserte el pico en la unidad principal y fíjelo apretando el tornillo lateral.

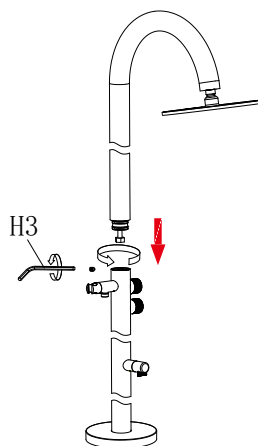

### Paso 7

Conecte la manguera de ducha tanto al cuerpo principal como a la ducha de mano.

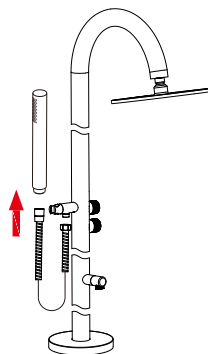

## ◆ Instrucciones de Funcionamiento

1. Cambio de Función de Salida de Agua:  
Gire la manija superior para cambiar entre las funciones de salida de agua.
2. Ajuste de Agua Caliente y Fría:  
Gire la manija en sentido horario para iniciar el flujo de agua; la temperatura cambia gradualmente de fría a caliente.

