

INSTALLATION GUIDE

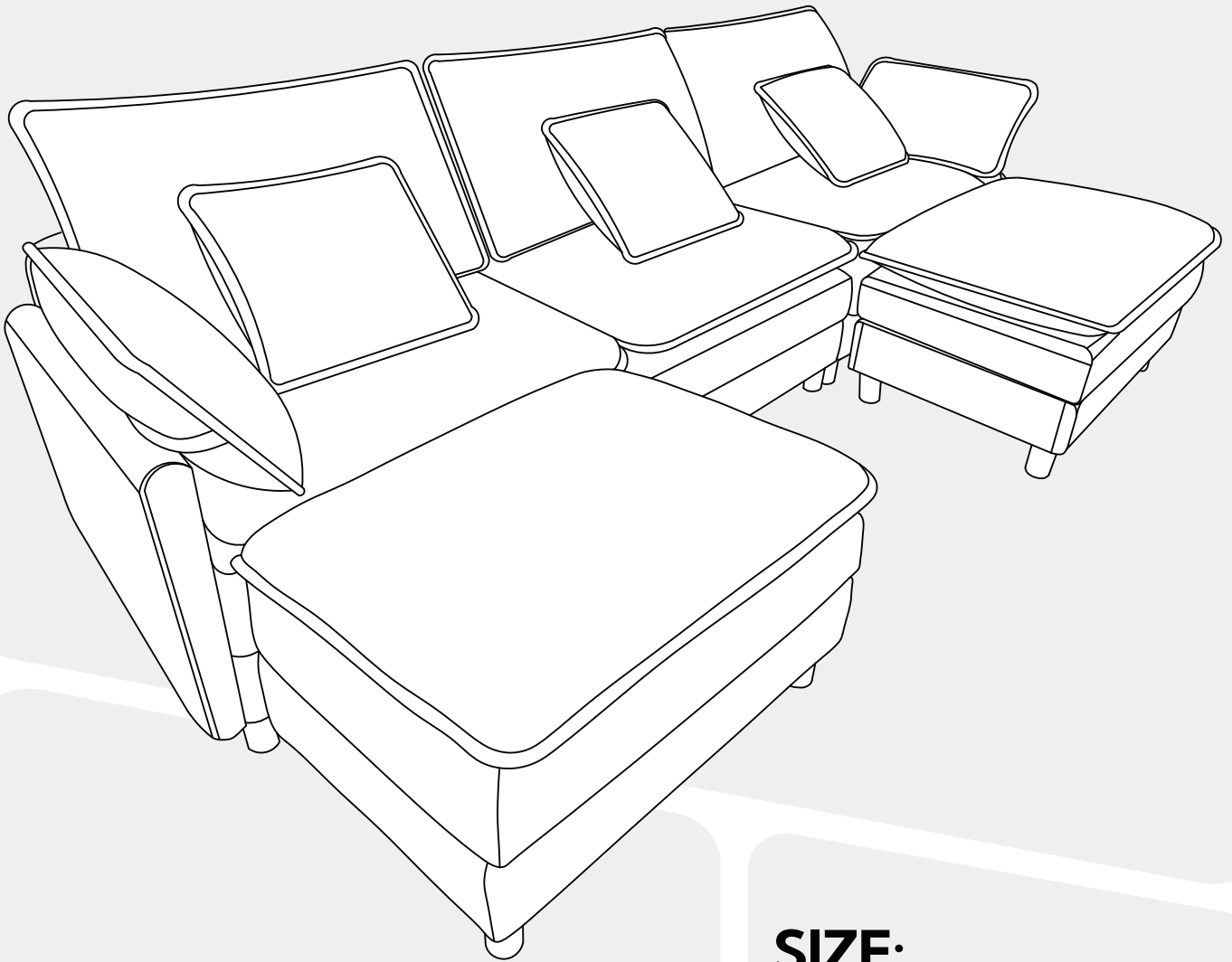

Sectional Cloud Couch

SIZE:

- 3-Seat & 1 Ottoman
- 3-Seat & 2 Ottoman
- 4-Seat & 2 Ottoman



Contact Us: mkxservice@outlook.com

SIZE

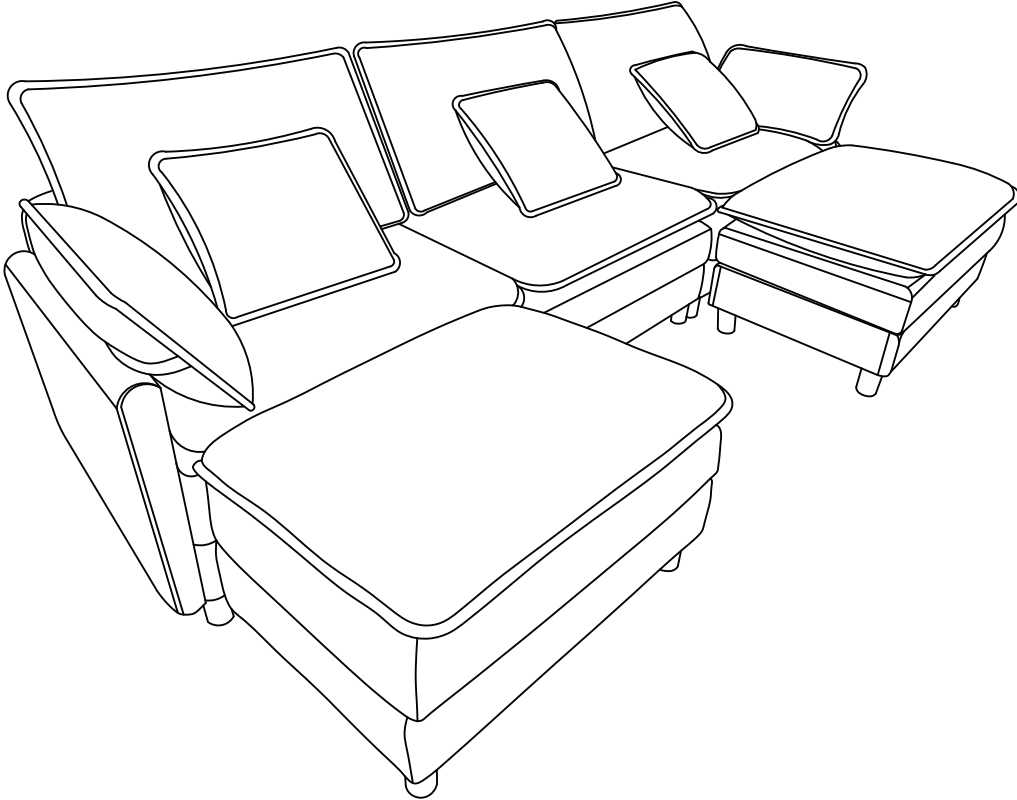

3-Seat & 1 Ottoman

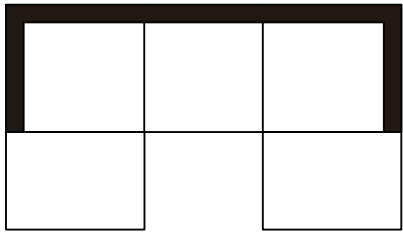

3-Seat & 2 Ottoman

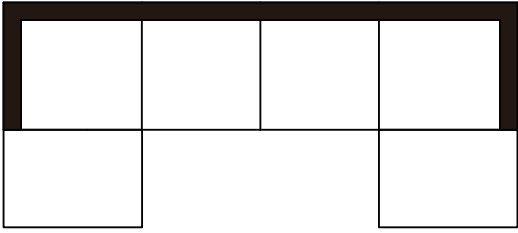

4-Seat & 2 Ottoman

Please be noted



Note:

Considering the large volume of product packaging, in order to meet practical needs and facilitate transportation, this couch will be divided into 2 or 3 separate packages for delivery, so they may not arrive at the same time.

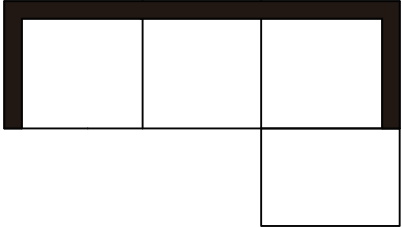

3-Seat & 1 Ottoman

Delivered in 2 Separate Packages

Package 1: 1 single sofa and 1 ottoman

Package 2: 2 single sofas

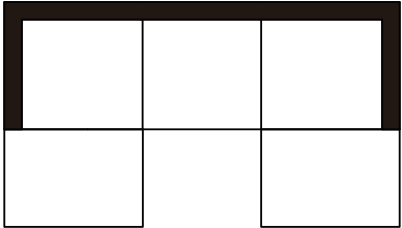

3-Seat & 2 Ottoman

Delivered in 3 Separate Packages

Package 1: 1 single sofa and 1 ottoman

Package 2: 2 single sofas

Package 3: 1 ottoman

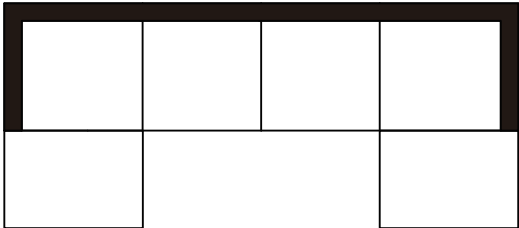

4-Seat & 2 Ottoman

Delivered in 3 Separate Packages

Package 1: 1 single sofa and 1 ottoman

Package 2: 2 single sofas

Package 3: 1 single sofa and 1 ottoman

Specifications



Power Input
110V-240V



Max.Load
300lbs/136kg

★ Caution:

To ensure optimal desk performance and longevity, we recommend not exceeding a daily weight capacity of 116 kg (256 lbs).

Please Note: The motor's operating noise may increase proportionally with heavier loads placed on the desk.

Vorsicht: Um eine optimale Leistung und Langlebigkeit des Schreibtischs zu gewährleisten, empfehlen wir, eine tägliche Tragkraft von 116 kg (256 lbs) nicht zu überschreiten.

Hinweis: Das Betriebsgeräusch des Motors kann proportional zu schwereren Lasten auf dem Schreibtisch zunehmen.

Attention: Pour garantir une performance et une longévité optimales du bureau, nous recommandons de ne pas dépasser une capacité de poids quotidienne de 116 kg (256 lb).

Remarque: Le bruit de fonctionnement du moteur peut augmenter proportionnellement à des charges plus lourdes placées sur le bureau.

Precaución: Para asegurar un rendimiento y una longevidad óptimos del escritorio, recomendamos no exceder una carga máxima diaria de 116 kg (256 lb).

Tenga en cuenta: El ruido de funcionamiento del motor puede aumentar proporcionalmente con cargas más pesadas colocadas sobre el escritorio.

お知らせ: 未長くご使用いただくためには、デスクに置くものの総重量はなるべく116kg以内に収めて下さい。

お知らせ: デスク上の総重量が増加すると、モーターの作動音も大きくなります。

주의: 더 나은 사용 경험을 위해 테이블의 일일 하중은 116kg 또는 256파운드를 초과하지 않는 것이 좋습니다.

주의: 책상의 하중 지지 능력이 증가함에 따라 모터에서 발생하는 소음도 증가함을 유의하시기 바랍니다.

Size Reference

★ NOTE:

If you're unsure about screw sizes, use the ruler provided on this page for easy comparison and installation.

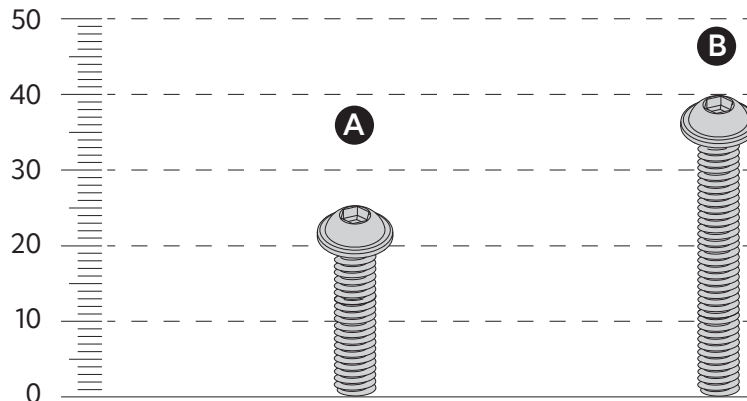

Wenn Sie sich bei den Schraubengrößen unsicher sind, verwenden Sie das Lineal auf dieser Seite zum einfachen Vergleich und zur Installation.



Si vous n'êtes pas sûr des tailles de vis, utilisez la règle fournie sur cette page pour une comparaison et une installation faciles.

Si no está seguro sobre los tamaños de los tornillos, use la regla proporcionada en esta página para una fácil comparación e instalación.



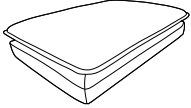
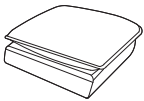
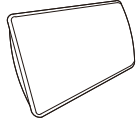

ネジのサイズがわからない場合は、このページの定規からご確認いただけます。

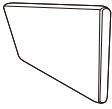
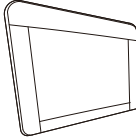
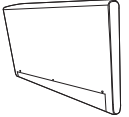
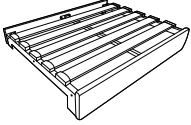
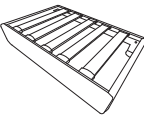
만약 당신이 나사의 치수에 익숙하지 않다면, 그 페이지의 치수와 비교하여, 나중에 설치할 수 있습니다.

Component List

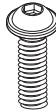

<p>01</p>  <p>Seat cushion (x3)</p>	<p>02</p>  <p>Footrest cushion (x2)</p>	<p>03</p>  <p>Backrest cushion (x3)</p>	<p>04</p>  <p>Armrest cushion (x2)</p>
<p>05</p>  <p>Lumbar cushion (x3)</p>	<p>06</p>  <p>Left armrest (x1)</p>	<p>07</p>  <p>Backrest (x3)</p>	<p>08</p>  <p>Right armrest (x1)</p>
<p>09</p>  <p>Seat frame (x3)</p>	<p>10</p>  <p>Footrest frame (x2)</p>		

Hardware List

<p>A</p>  <p>Screws M6x25mm (x12)</p>	<p>B</p>  <p>Screws M6x40mm (x12)</p>	<p>C</p>  <p>Plastic feet (x20)</p>	<p>D</p>  <p>3/16" (5mm)</p>
<p>E</p>  <p>Butterfly nuts (x6)</p>			



! Note: The numbers 01 to 10 are only for identification purposes and are not labeled. The labels A to E correspond to the fixtures and fittings supplied in the package. In addition, there will be a package of spare parts inside the packaging box.

1

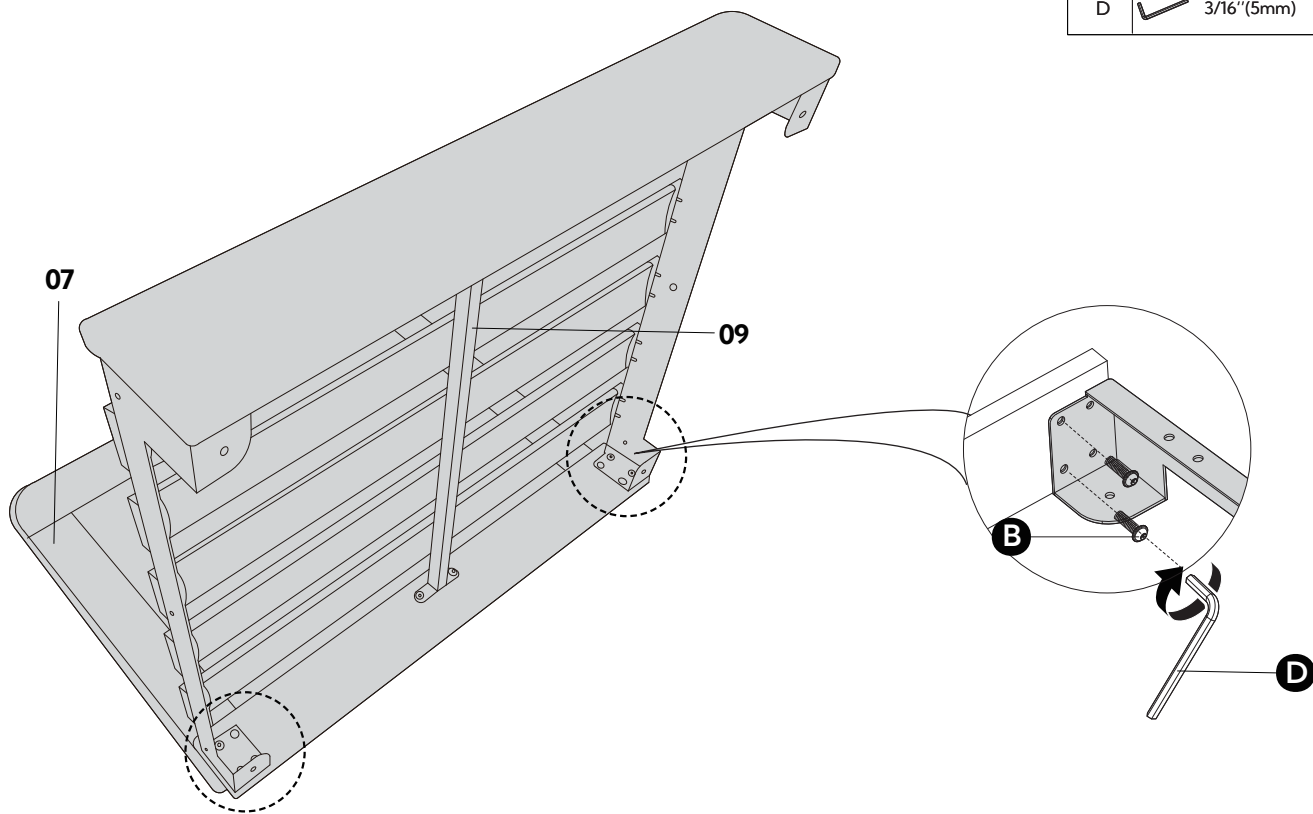
B	 M6x40mm(x4)
D	 3/16"(5mm)



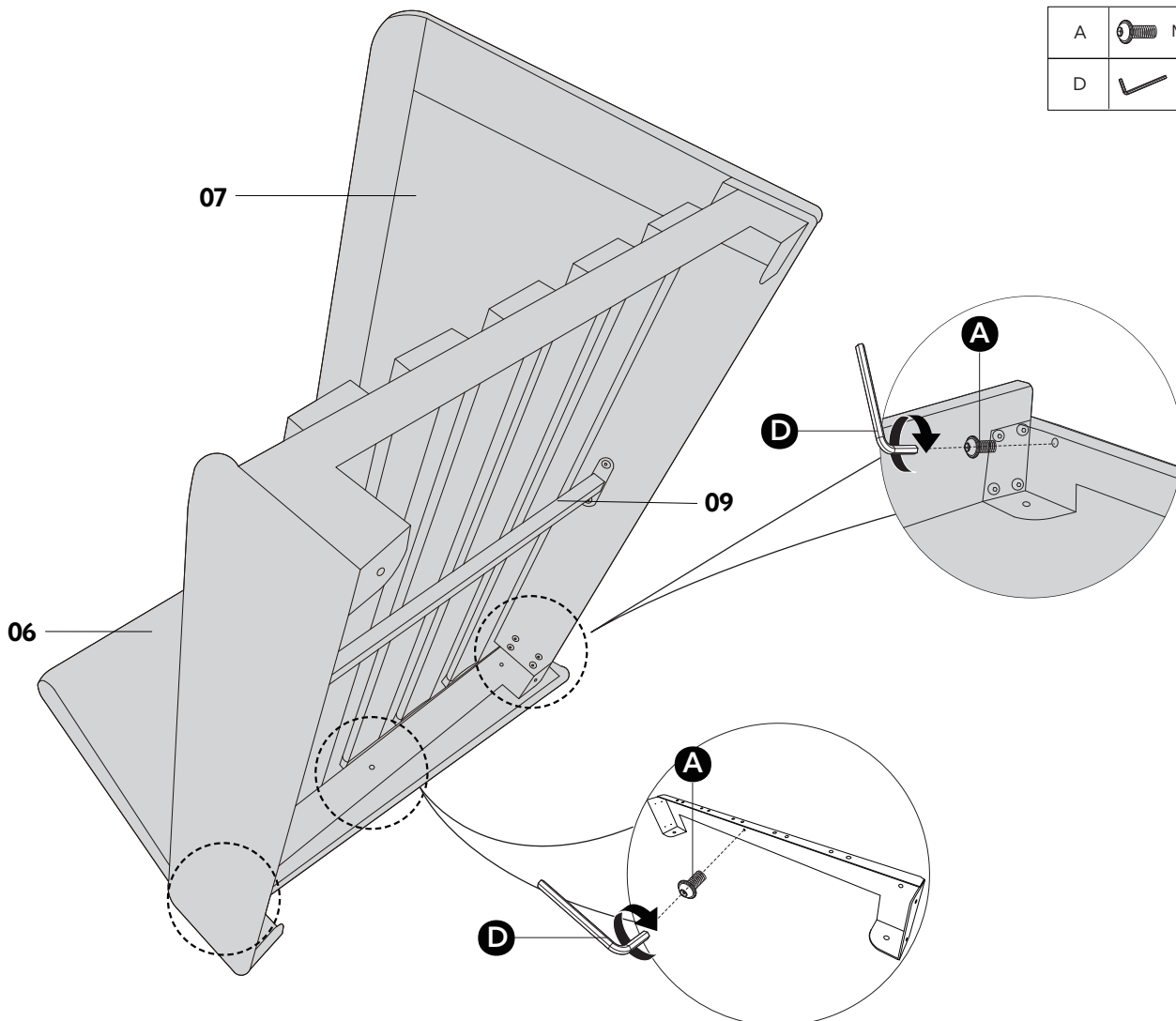

2

A	 M6x25mm(x3)
D	 3/16"(5mm)



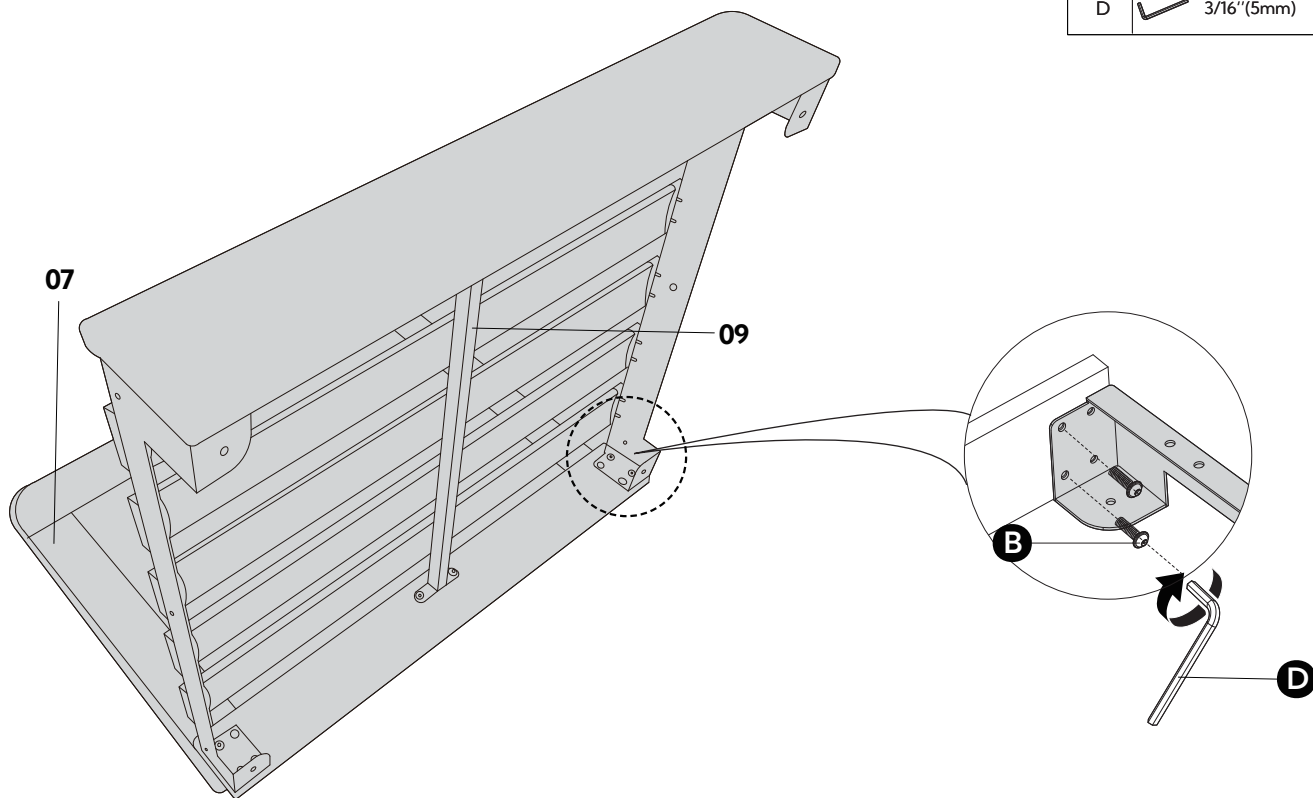

3

B	 M6x40mm(x4)
D	 3/16"(5mm)



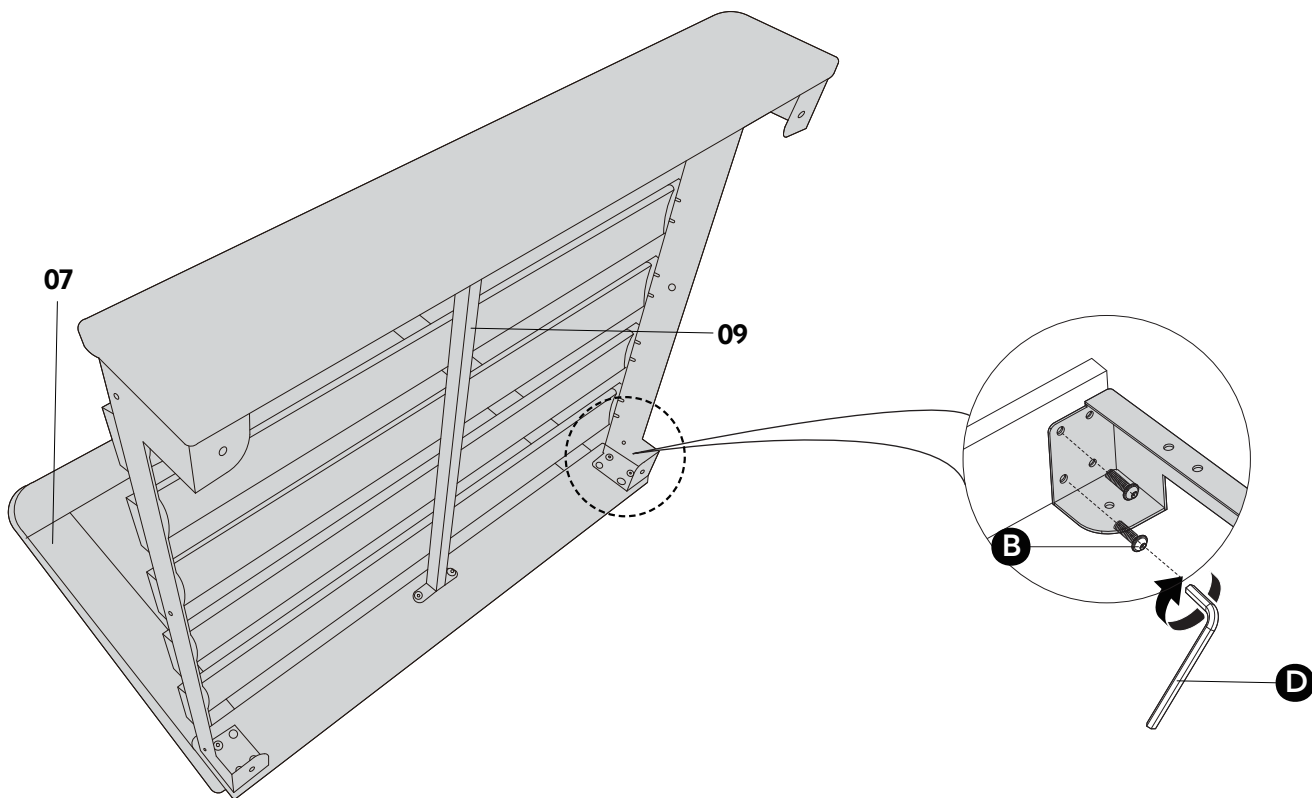

4

B	 M6x40mm(x4)
D	 3/16"(5mm)



5

A	 M6x25mm(x3)
D	 3/16"(5mm)

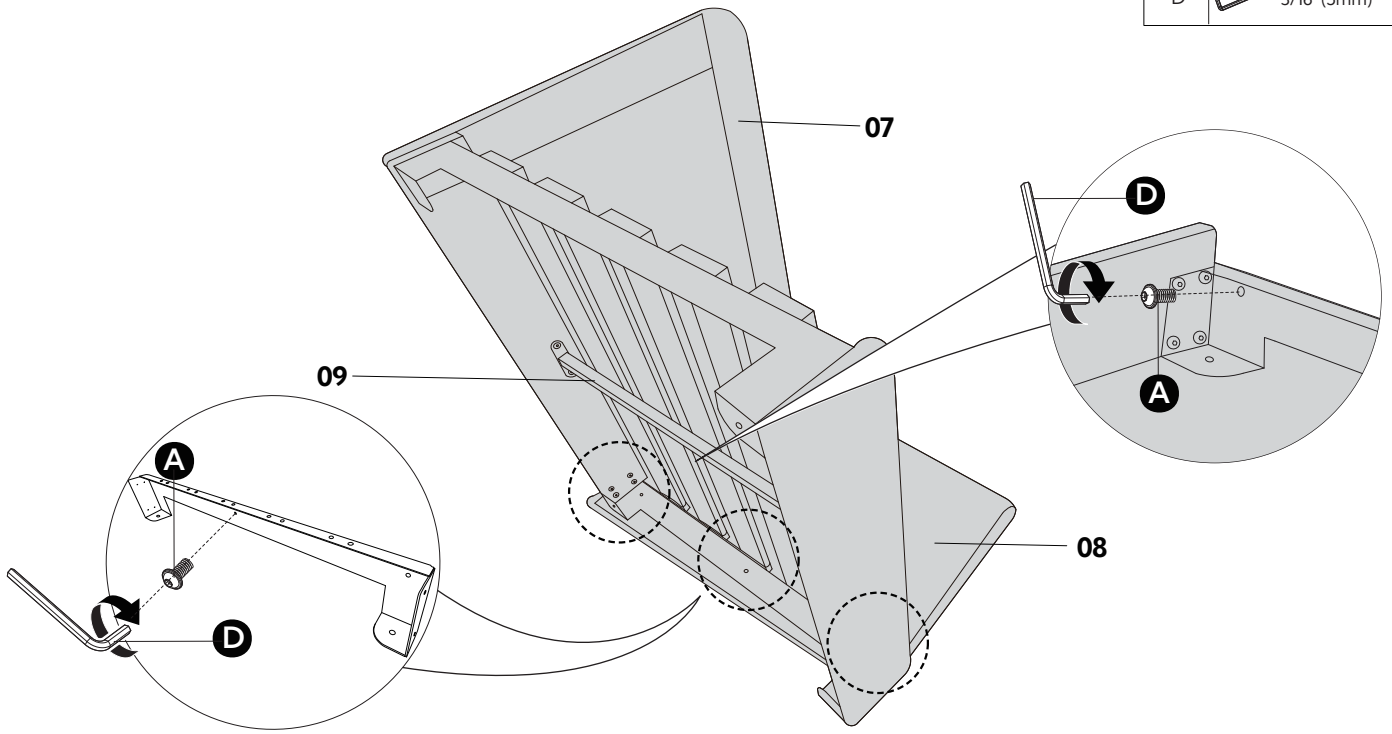

6

C	 Plastic feet(x20)
---	---

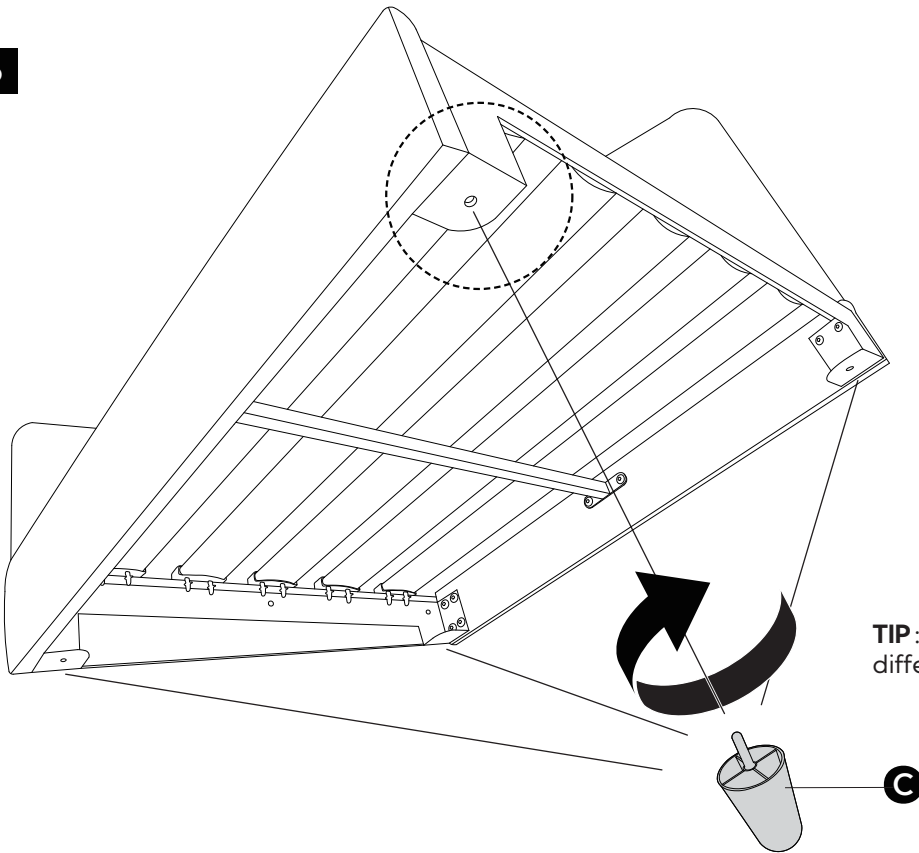

TIP: Install this bottom screw according to different seating combination requirements.

X5

TIPP: Installieren Sie diese untere Schraube entsprechend den verschiedenen Sitzkombination-sanforderungen.



① CONSEIL : Installez cette vis inférieure selon les différentes exigences de combinaison de sièges.

① CONSEJO: Instale este tornillo inferior según las diferentes necesidades de combinación de asientos.

① ヒント: 異なる座席組み合わせのニーズに応じて、この底部のネジを取り付けてください。

① 팁: 다양한 좌석 조합 요구에 따라 이 하단 나사를 설치하십시오.

7

A	 M6x25mm(x6)
D	 3/16"(5mm)
E	 Butterfly nuts (x6)

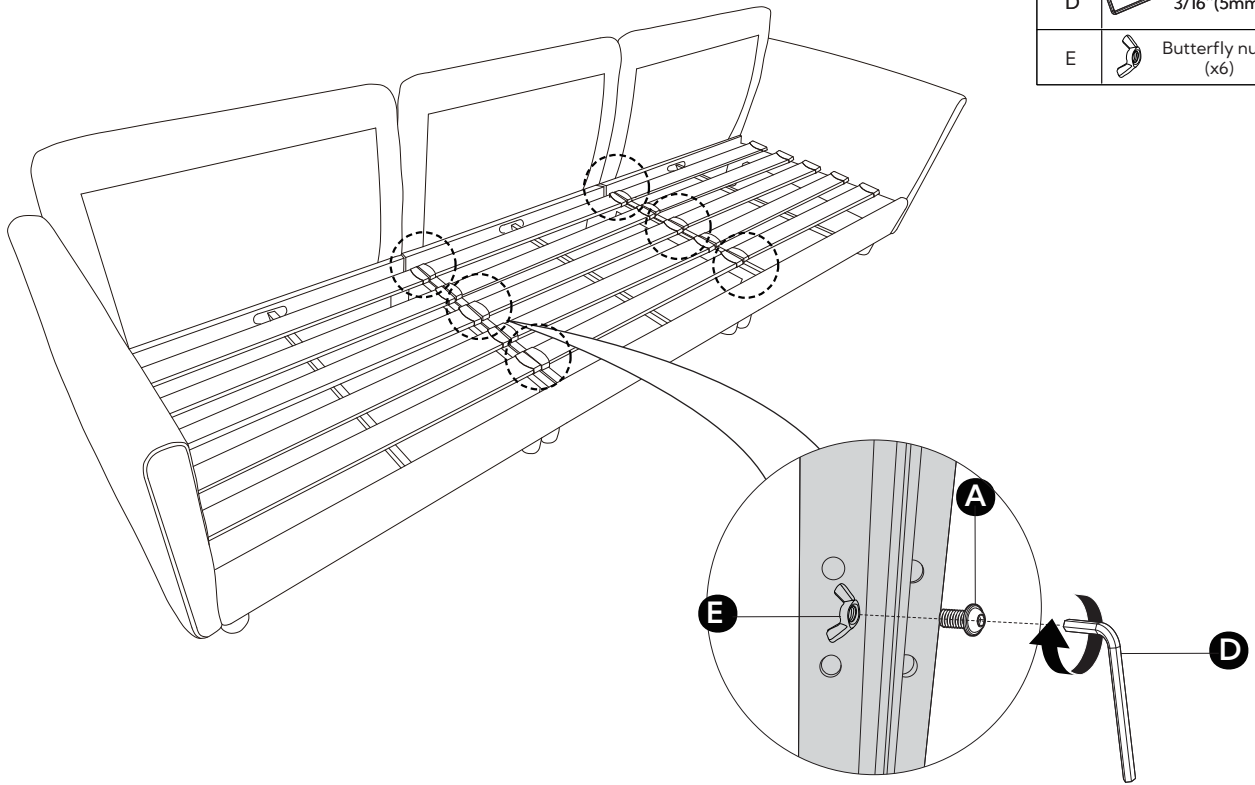

8

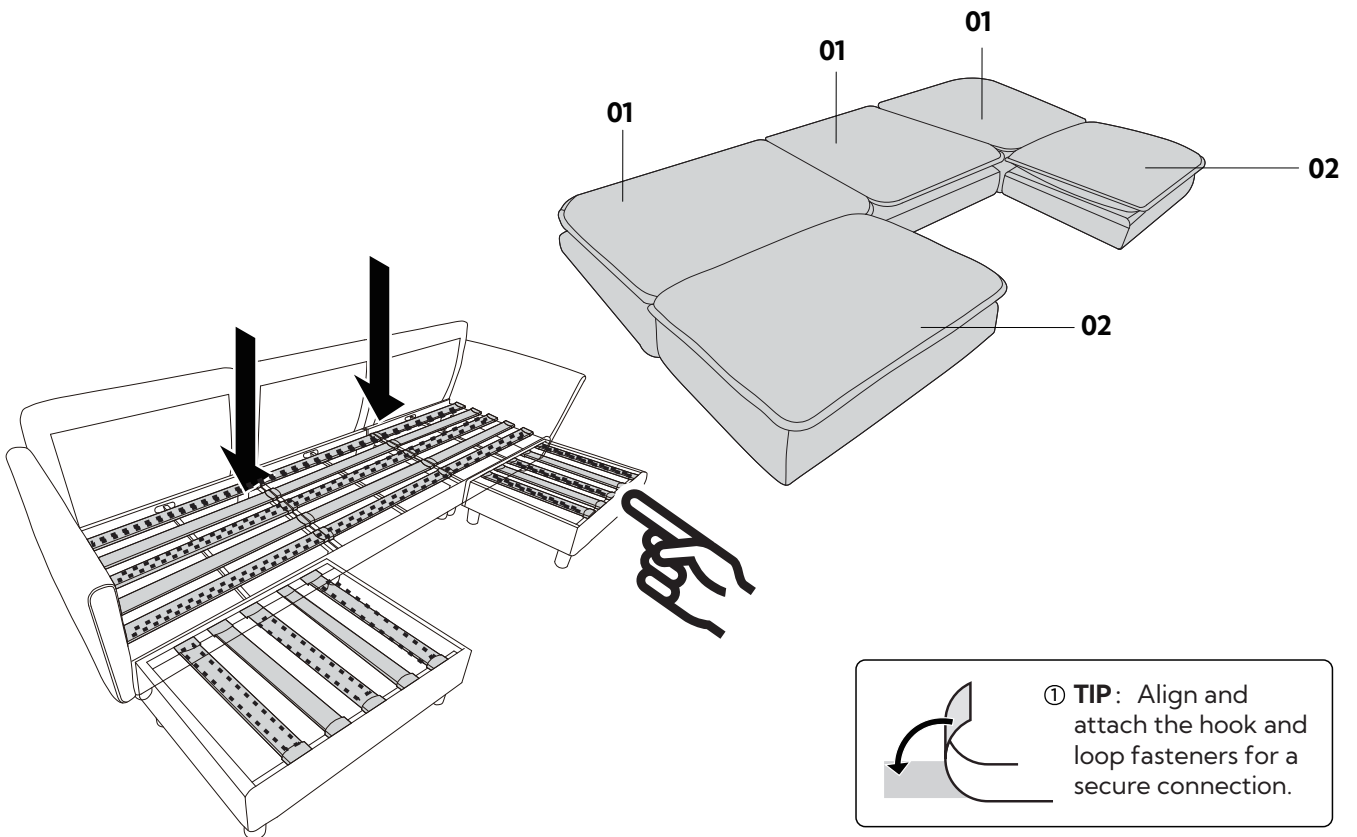

 ① **TIP:** Align and attach the hook and loop fasteners for a secure connection.

<p>TIPP: Richten Sie die Klettverschlüsse aus und befestigen Sie sie, um eine sichere Verbindung zu gewährleisten.</p>	<p>① CONSEIL : Alignez et attachez les fermetures à scratch pour une connexion sécurisée.</p>	<p>① CONSEJO: Alinee y fije los cierres de velcro para una conexión segura.</p>	<p>① ヒント: フックアンドループファスナーを位置合わせて取り付け、しっかりとした接続を行ってください。</p>	<p>① 팁: 후크 앤 루프 패스너를 정렬하고 부착하여 안전한 연결을 만드십시오.</p>
--	---	---	--	---

9

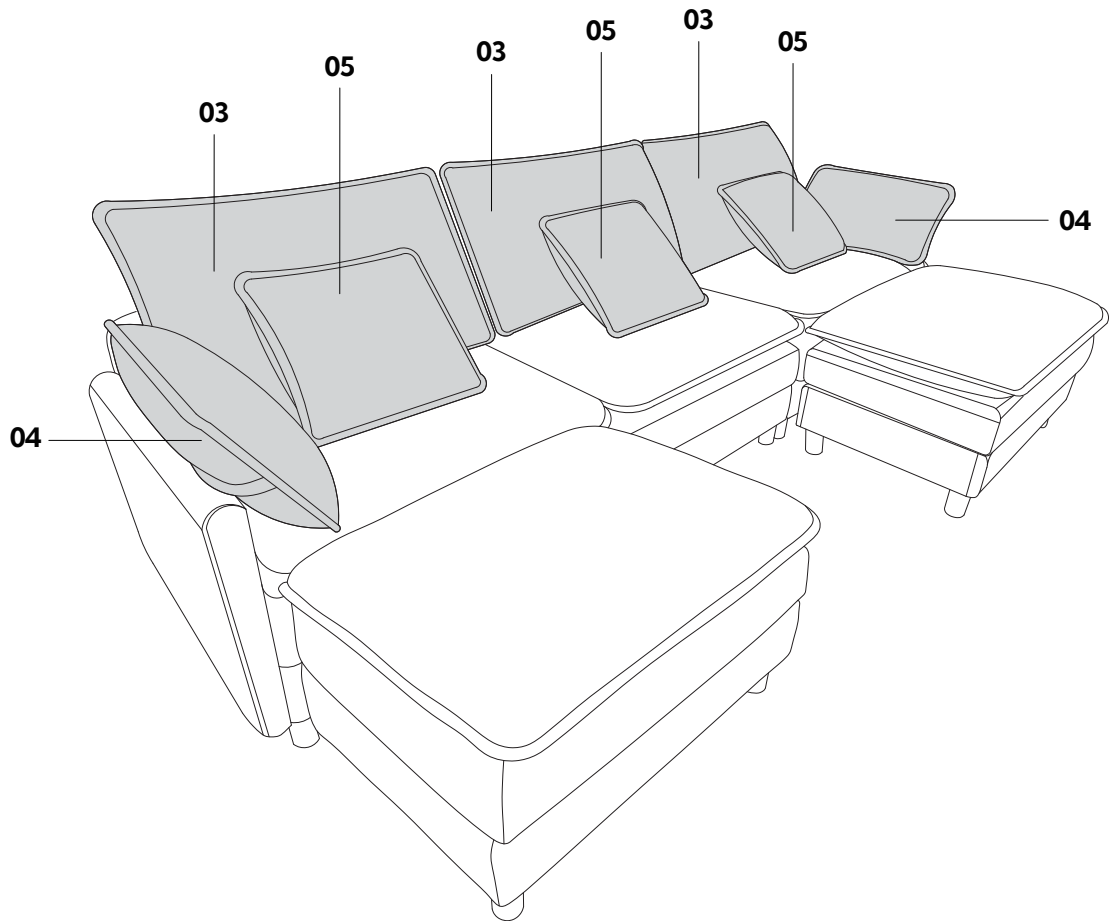

10

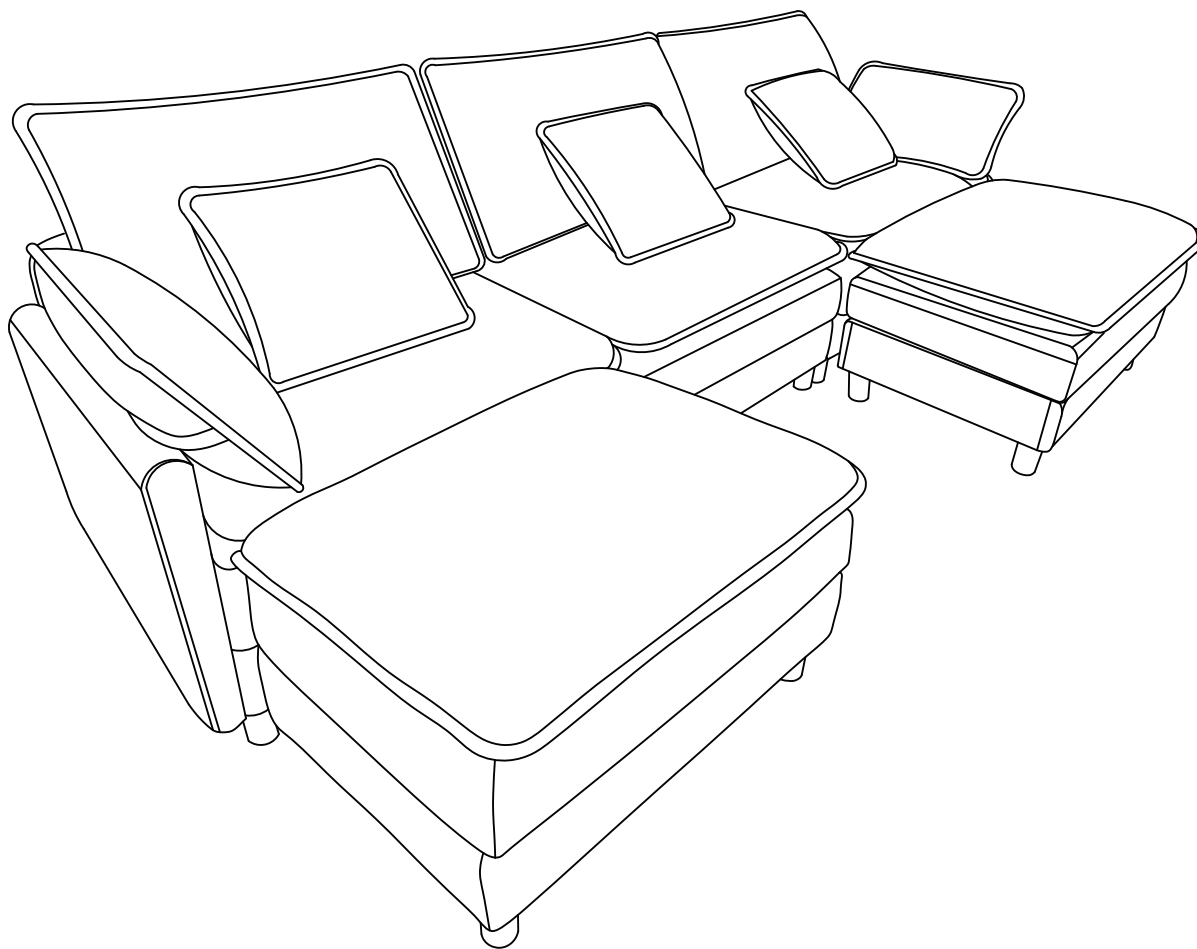



Customer Support:
mkxservice@outlook.com

MADE IN CHINA