

# ASSEMBLY INSTRUCTIONS

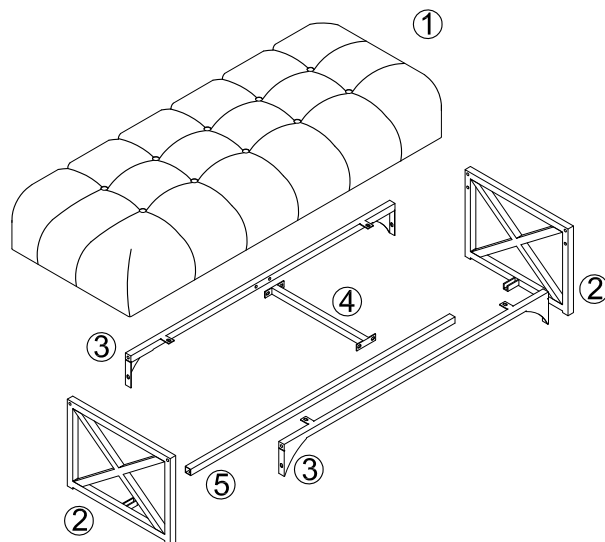

## PARTS IDENTIFICATION:

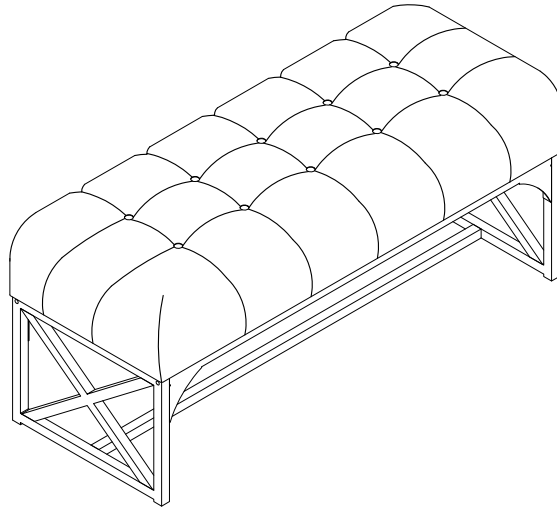

ITEM	DESCRIPTION	QTY
#1	CUSHION	01
#2	X FRAME	02
#3	UPPER STRETCHER	02
#4	UPPER MIDDLE STRETCHER	01
#5	LOWER STRETCHER	01

For ease of identification all parts are labeled to correspond to the step number in which the part is used











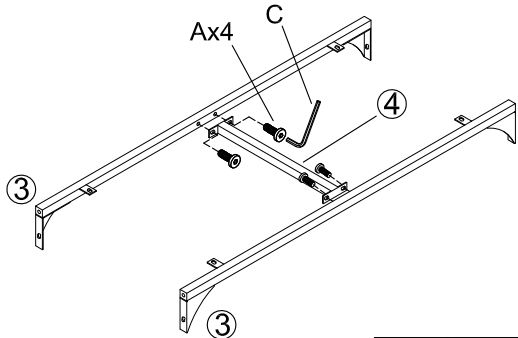



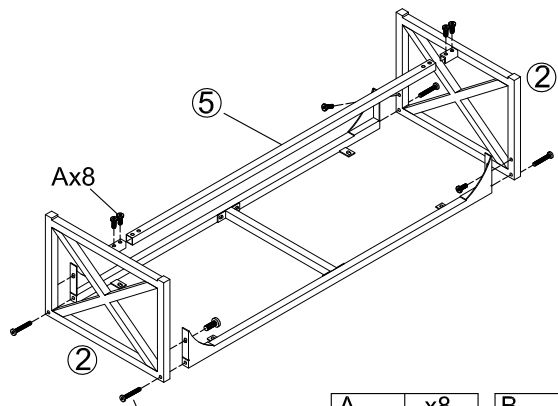

**NOTE:DO NOT TIGHTEN ANY OF THE BOLTS UNTIL IS FULLY ASSEMBLED**

**HARDWARE IDENTIFICATION:**

Please line up the hardware with the correct full size image to make sure you are installing the hardware correctly.

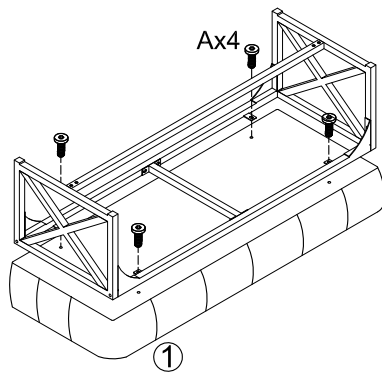
ITEM	PICTURE	DESCRIPTION	QTY
A	 Ø1/4x5/8"	SHORT BOLT	16
B	 Ø1/4x1.5"	LONG BOLT	04
C	 1/4"	ALLEN WRENCH	01

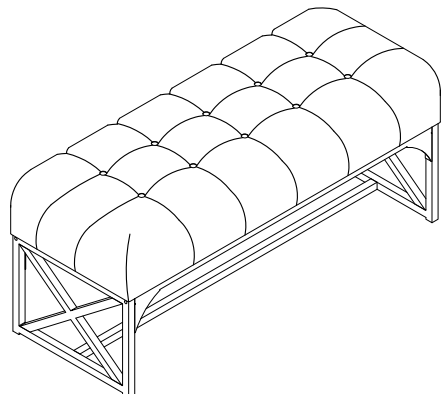
**STEP:**

<p><b>STEP 1</b></p>  <table border="1" data-bbox="475 1160 790 1276"> <tr> <td>A</td> <td>x4</td> <td>C</td> <td>x1</td> </tr> <tr> <td></td> <td></td> <td></td> <td></td> </tr> <tr> <td colspan="2">Ø1/4x5/8"</td> <td colspan="2">1/4"</td> </tr> </table>	A	x4	C	x1					Ø1/4x5/8"		1/4"		<p><b>STEP 2</b></p>  <table border="1" data-bbox="1197 1160 1513 1276"> <tr> <td>A</td> <td>x8</td> <td>B</td> <td>x4</td> </tr> <tr> <td></td> <td></td> <td></td> <td></td> </tr> <tr> <td colspan="2">Ø1/4x5/8"</td> <td colspan="2">Ø1/4x1.5"</td> </tr> </table>	A	x8	B	x4					Ø1/4x5/8"		Ø1/4x1.5"	
A	x4	C	x1																						
																									
Ø1/4x5/8"		1/4"																							
A	x8	B	x4																						
																									
Ø1/4x5/8"		Ø1/4x1.5"																							
<p><b>STEP 3</b></p>  <table border="1" data-bbox="638 1774 790 1890"> <tr> <td>A</td> <td>x4</td> </tr> <tr> <td></td> <td></td> </tr> <tr> <td colspan="2">Ø1/4x5/8"</td> </tr> </table>	A	x4			Ø1/4x5/8"		<p><b>STEP 4</b></p> 																		
A	x4																								
																									
Ø1/4x5/8"																									

**IMPORTANT:**

- 1.DO NOT TIGHTEN BOLTS COMPLETELY UNTIL ALL BOLTS ARE COMPLETELY LINED UP AND INSERTED INTO HOLES/NUTS.
- 2.DO NOT OVER TIGHTEN SCREWS AND BOLTS TO AVOLD STRIPPING.
- 3.AFTER USING 3 TO 5 MONTHS,CHECK ALL THE BLOTS AND TIGHTEN ANY ONE IF NECESSARY