

ASSEMBLY INSTRUCTIONS

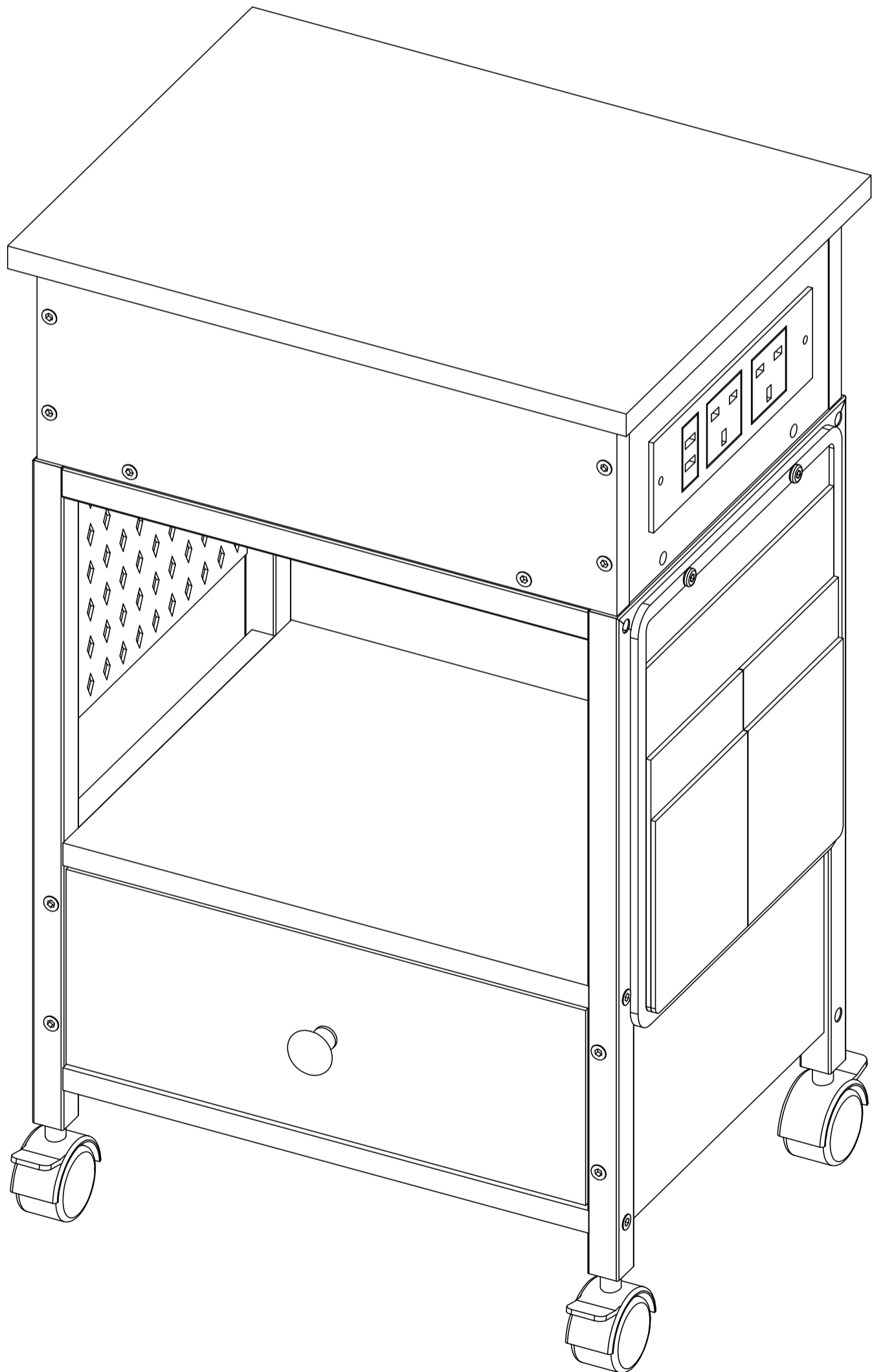

Preparation before installation

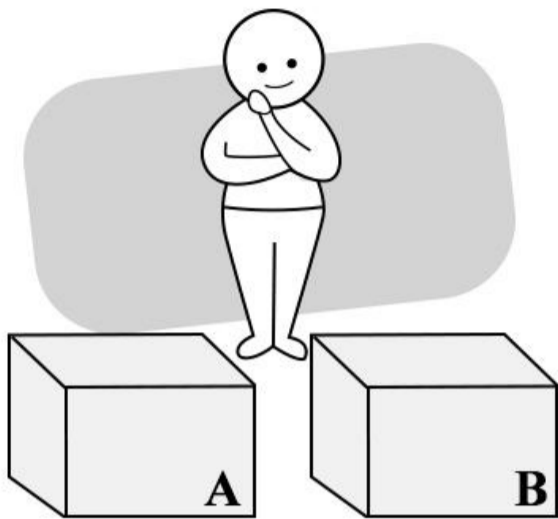

Check the number of parcels before you begin assembly

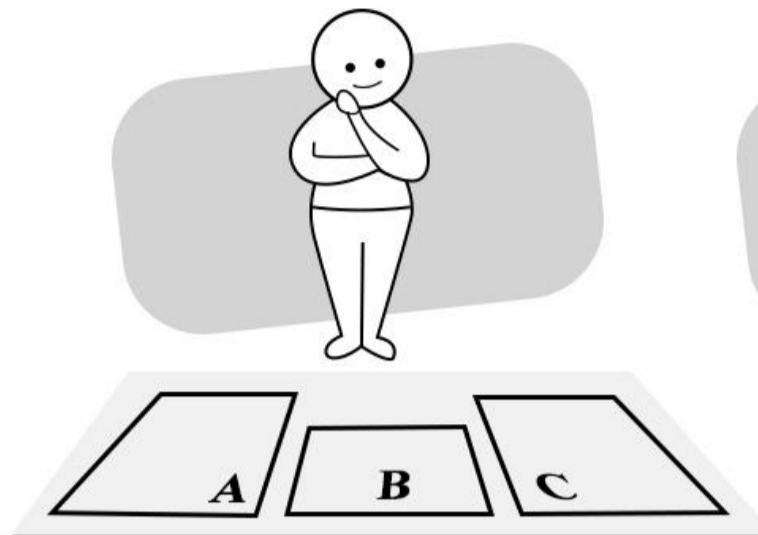

Identify and lay out all of the components before you begin assembly
(It is best to spread it on the ground)



Read through the instructions carefully before you begin

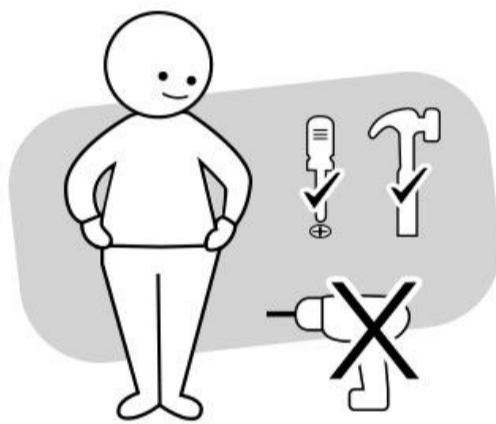

Make sure you have all the required tools.
Never use power tools unless instructed.

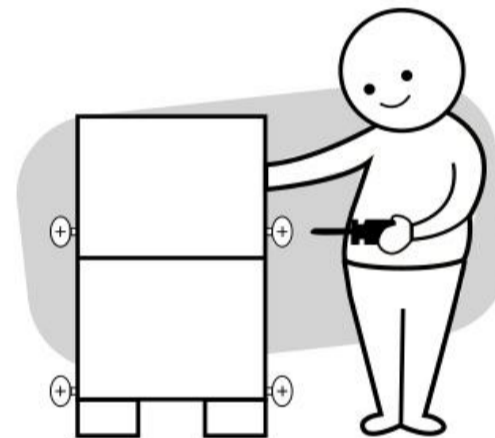

Unless instructed, do not fully tighten screws until the item is fully assembled.

Important before assembly:

- ! Read these instructions carefully before assembling or using the product.
- ! Please check the contents of the boxes before attempting to assemble this product. The instructions will have a checklist of parts and fittings.
- ! It would be sensible to lay a rug or a carpet on the floor where you intend to assemble the product, to avoid scratches and damaging the product or the floor.
- ! Assemble the product as close to its intended final location/room as possible.
- ! Do **NOT** use any power tools as this may damage the frame.



Safety and Care Advice

Important – Please read these instructions fully before starting assembly

- Check you have all the components and tools listed on the following pages.
- Remove all fittings from the plastic bags and separate them into their groups.
- Keep children and animals away from the work area, small parts could choke if swallowed.
- Make sure you have enough space to lay out the parts before starting.

- During assembly, do not stand or put weight on the product, this could cause damage.
- Assemble the item as close to its final position (in the same room) as possible.
- Assemble on a soft level surface to avoid damaging the unit or your floor.
- Parts of the assembly will be easier with 2 people.



- We do not recommend the use of power drivers for inserting screws, as this could damage the unit. Only use hand screw drivers.

Glue safety - Take care when using glue, please follow the advice below

Skin contact: Remove contamination by washing with soap and water. This procedure should also be followed prior to eating and drinking.

Eye contact: Rinse immediately with clean water for 15 minutes and seek medical advice.

If swallowed: Seek medical advice immediately.

Care and maintenance

- Only clean using a damp cloth and mild detergent, do not use bleach or abrasive cleaners.

- From time to time check that there are no loose screws on this unit.

- This product should not be discarded with household waste. Take to your local authority waste disposal centre.

Note: if required the next page can be cut out and used as reference throughout the assembly. Keep this page with these instructions for future reference.

Part list

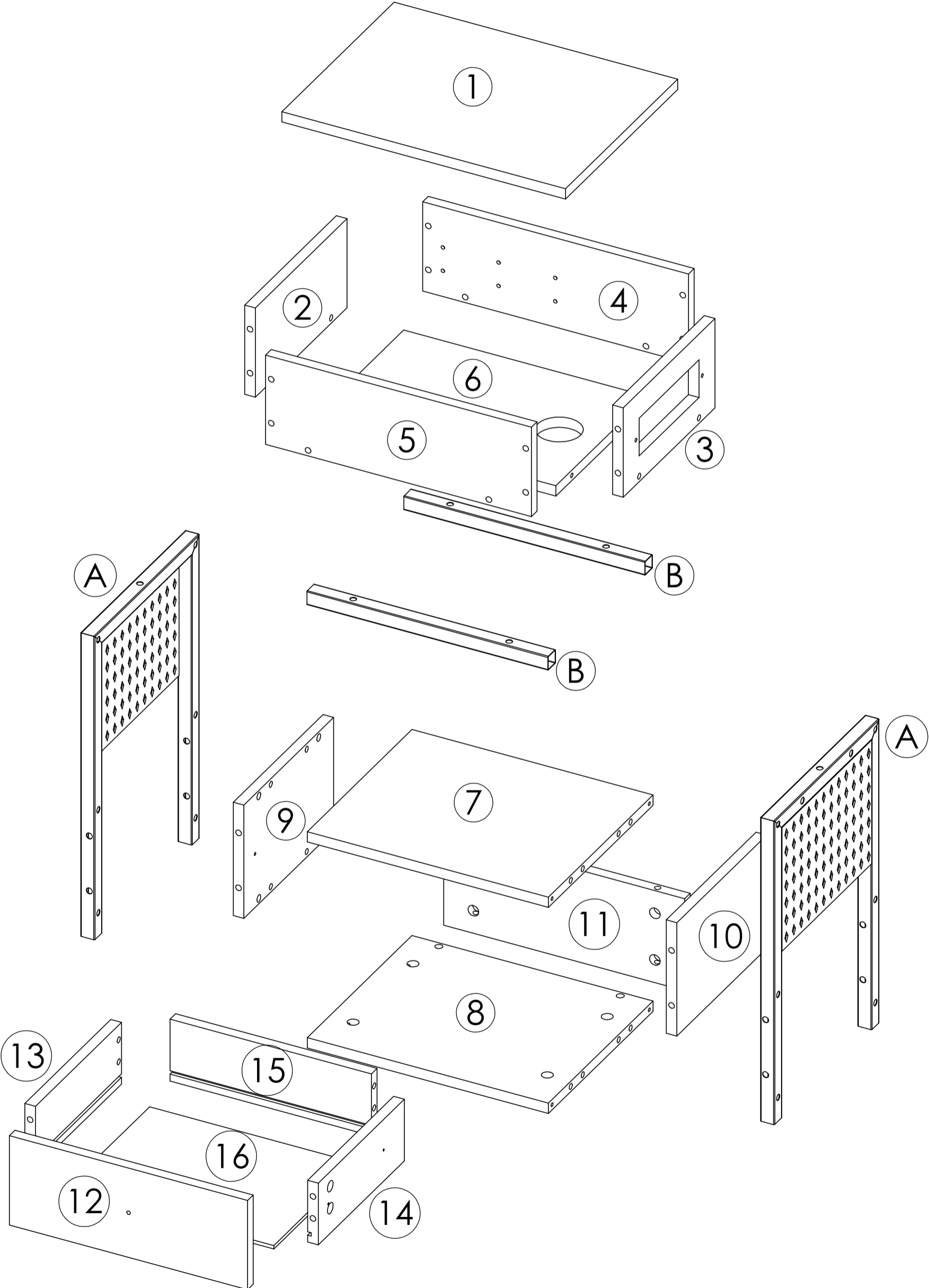

Hardware list

A X 2

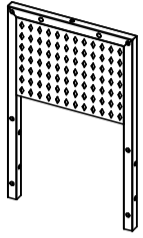

B X 2



C X 20



D X 20



E X 8



ϕ 8X40mm

F X 38



ϕ 6.3X40mm

G X 4

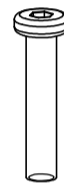

ϕ 6X35mm

H X 2



ϕ 6X10mm

J X 36



ϕ 3.5X14mm

K X 1

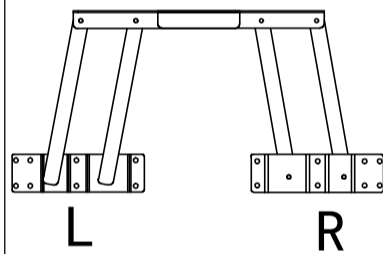

L X 4

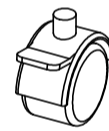

M X 1

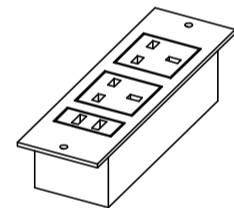

N X 1

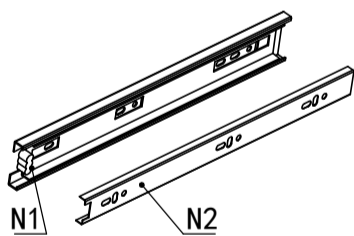

O X 1



P X 1

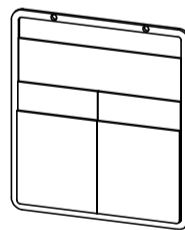

Q X 1

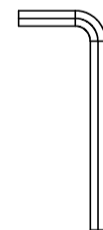

R X 1



Warm Reminder

Before installing the drawer rail, you need to separate the Part-1 and Part-2 first.

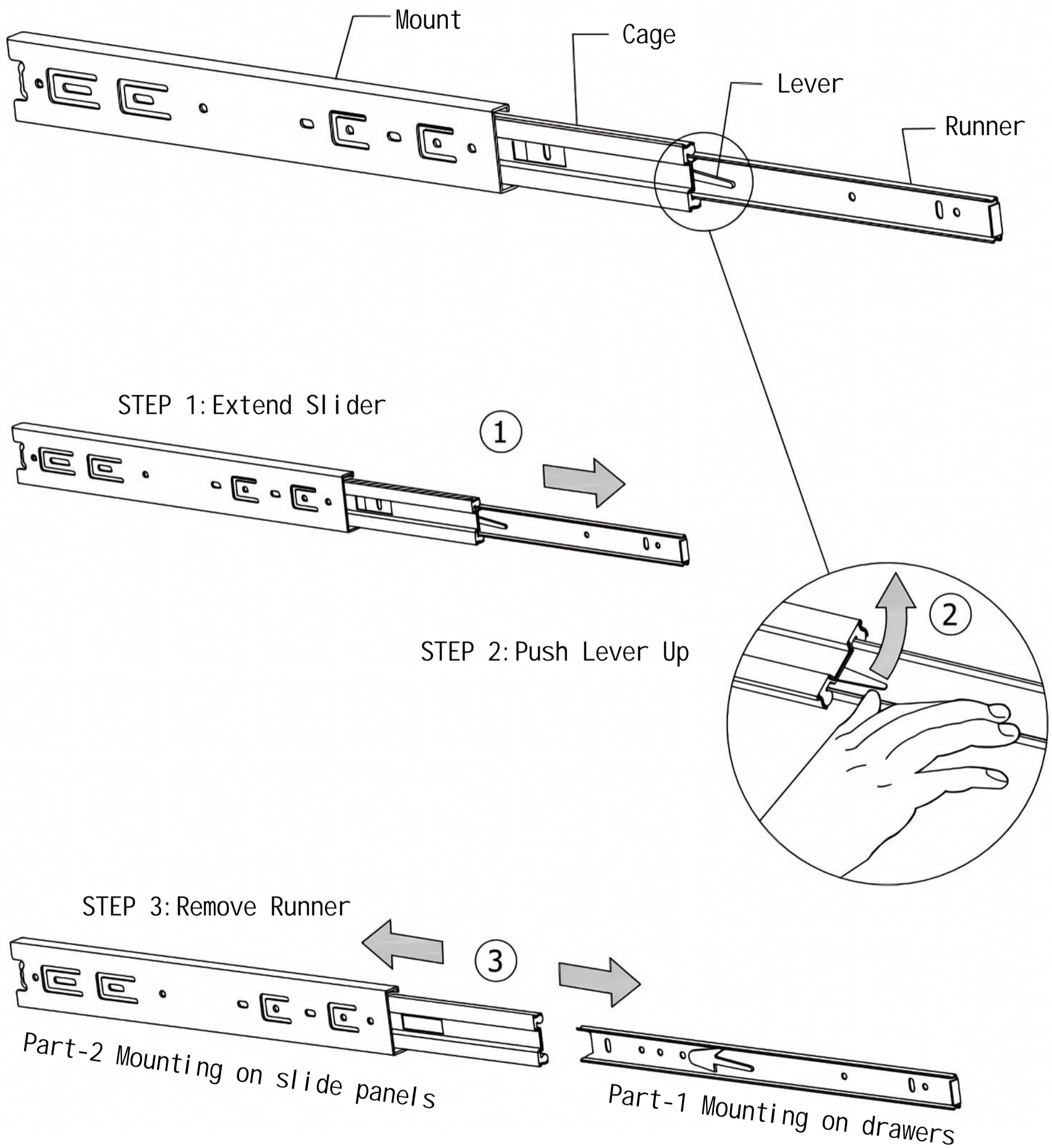

STEP 1

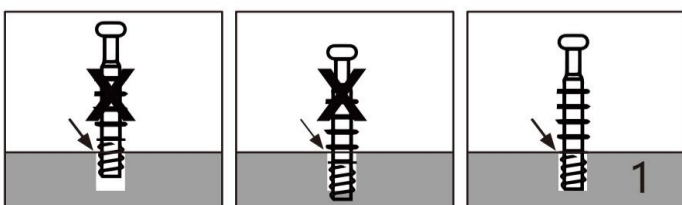
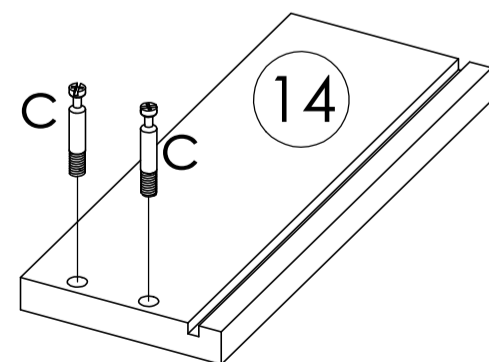
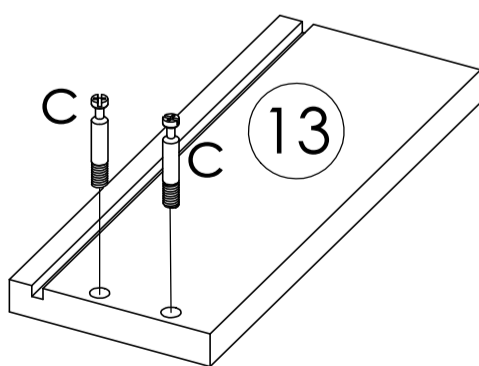
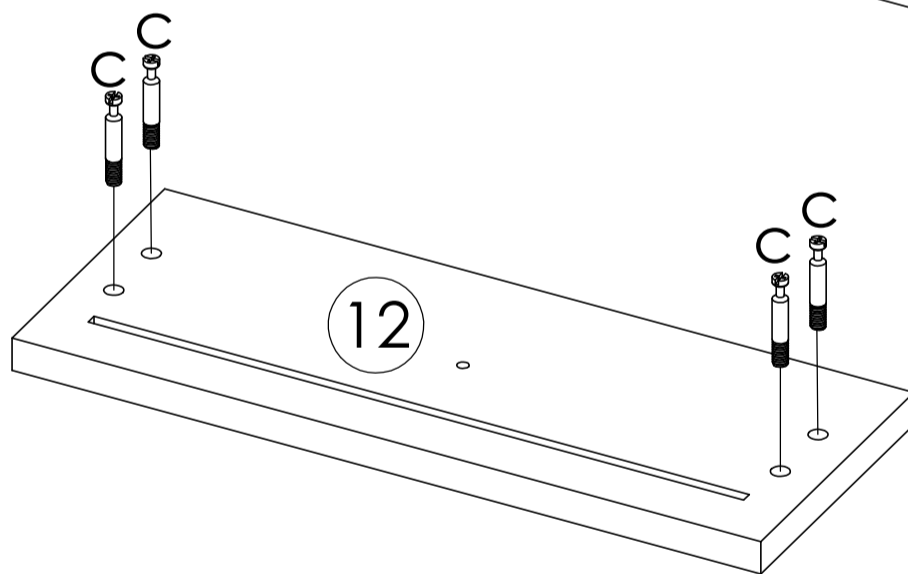
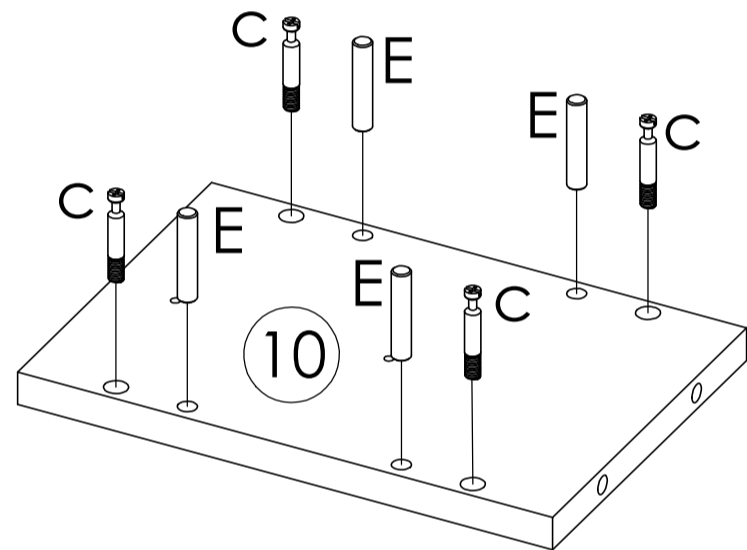
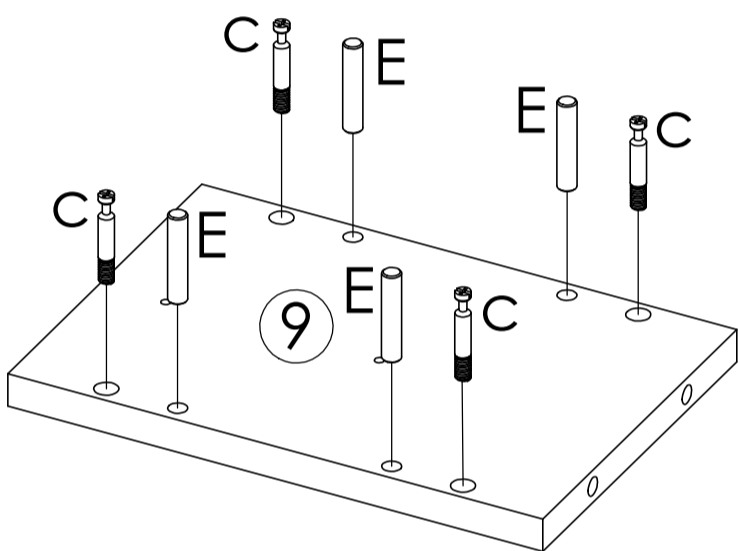
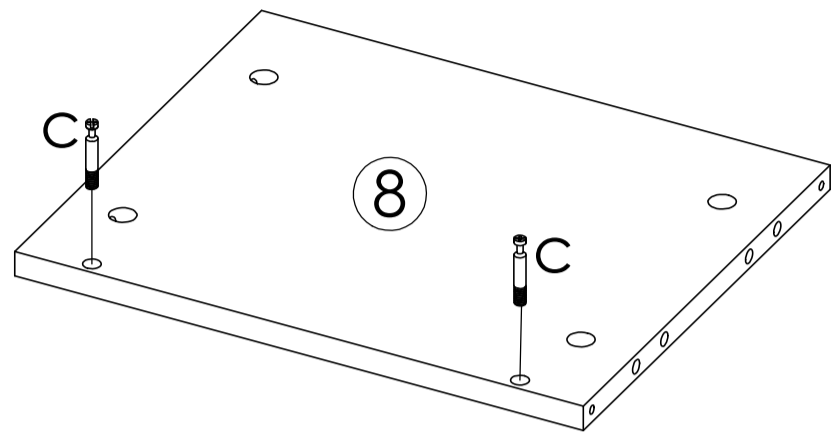
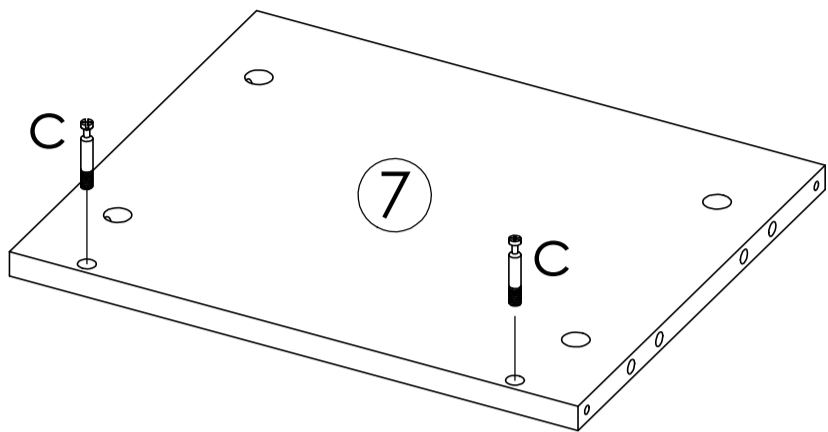

C X 20 E X 8

STEP 2

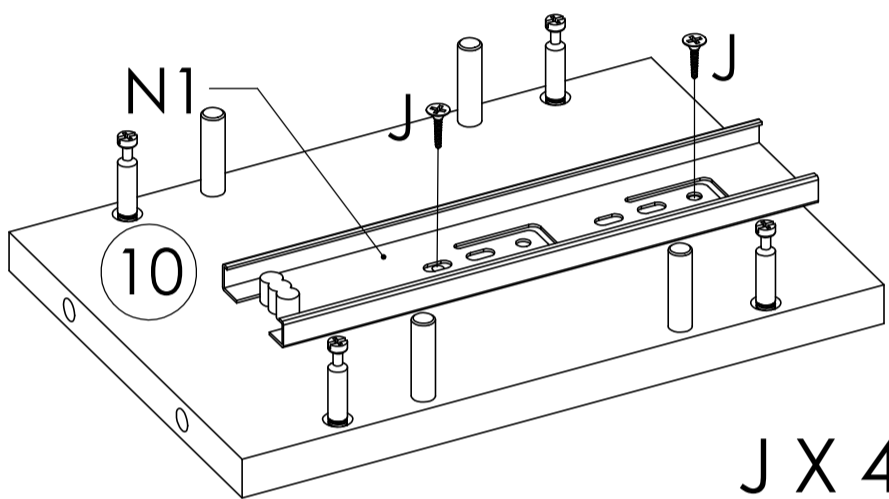
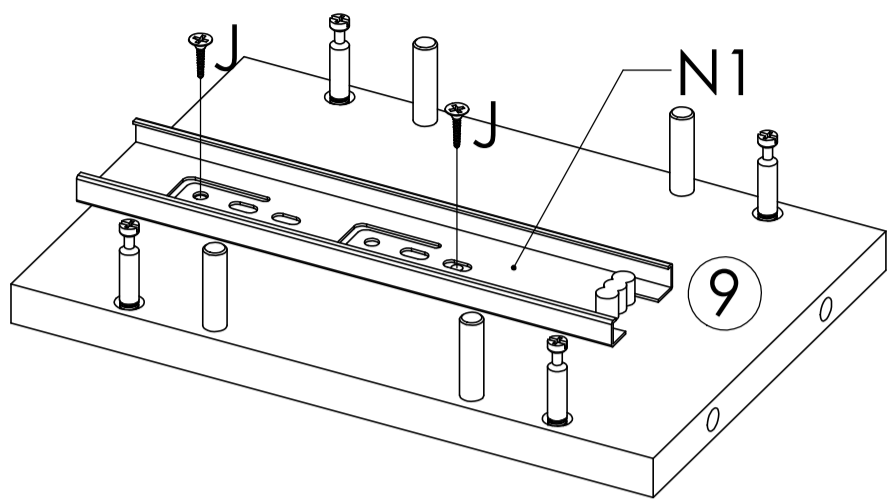

J X 4
N1 X 2

STEP 3

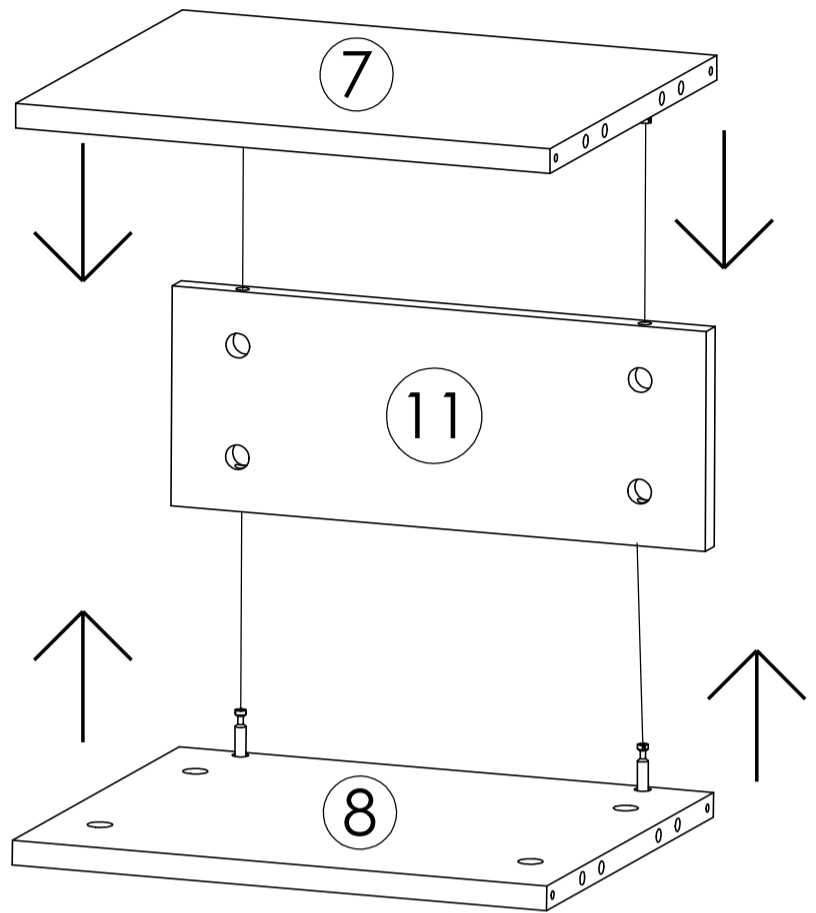

STEP 4

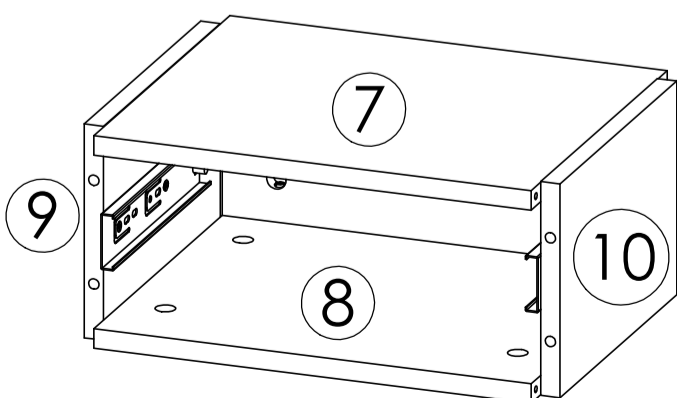
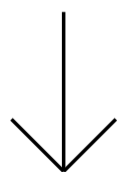
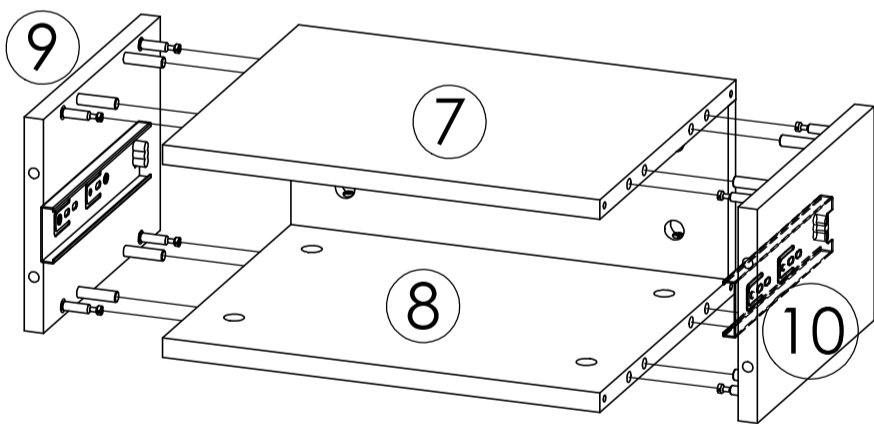

STEP 5

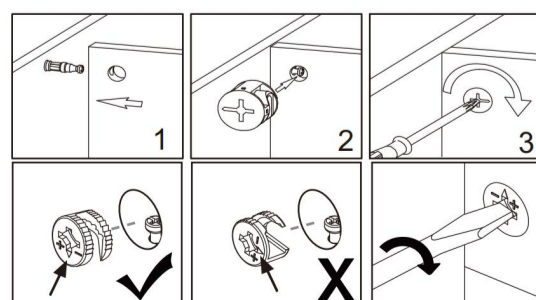
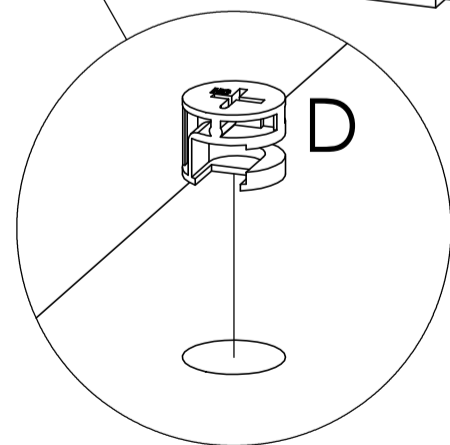
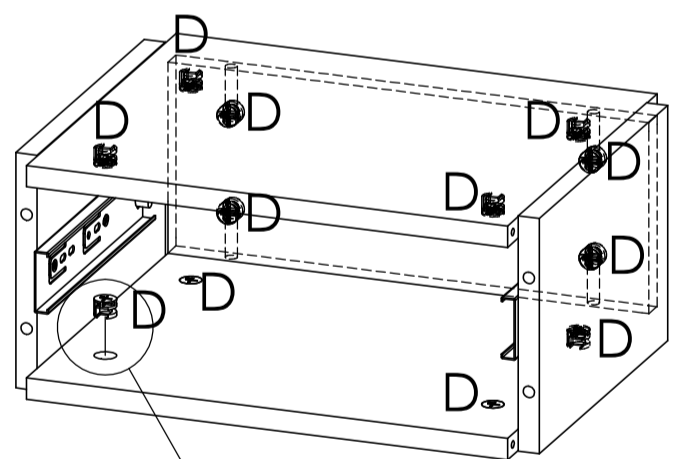

D X 12

STEP 6

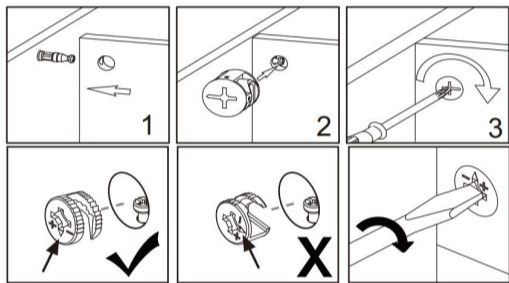
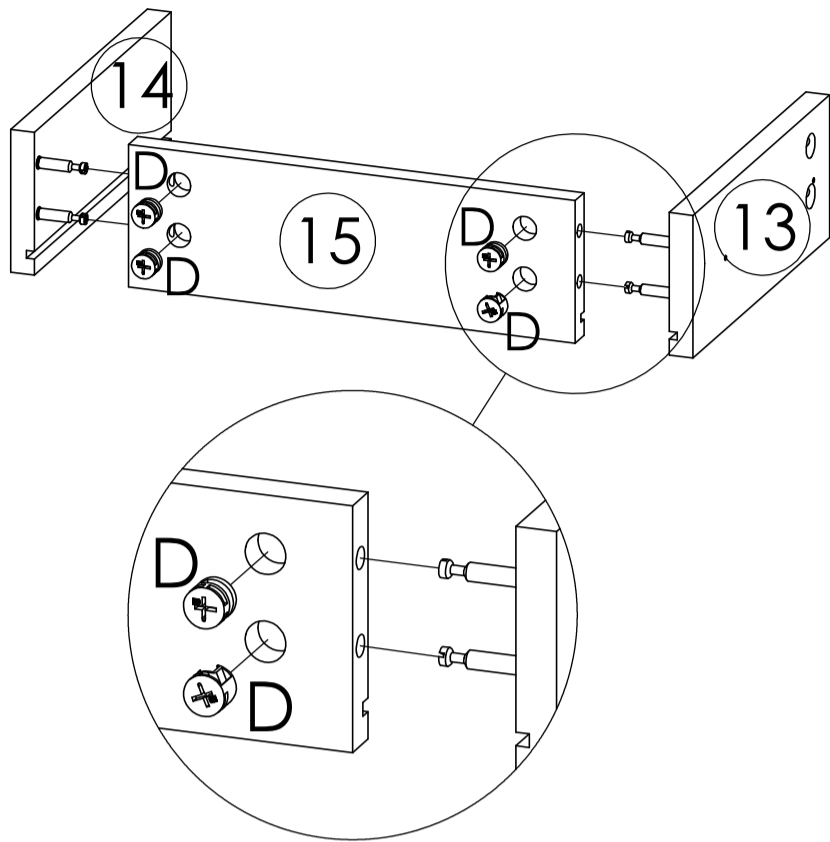

D X 4

STEP 7

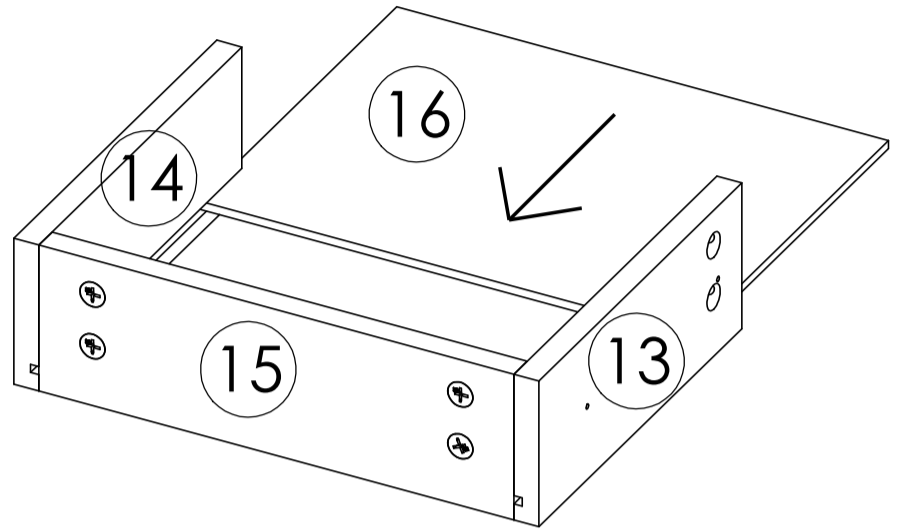

STEP 8

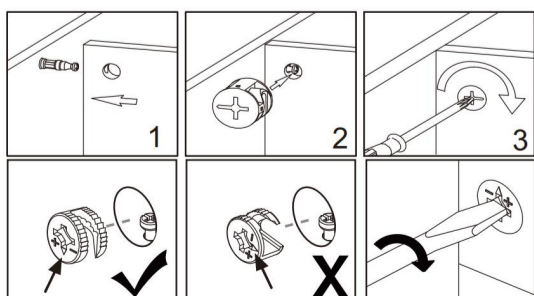
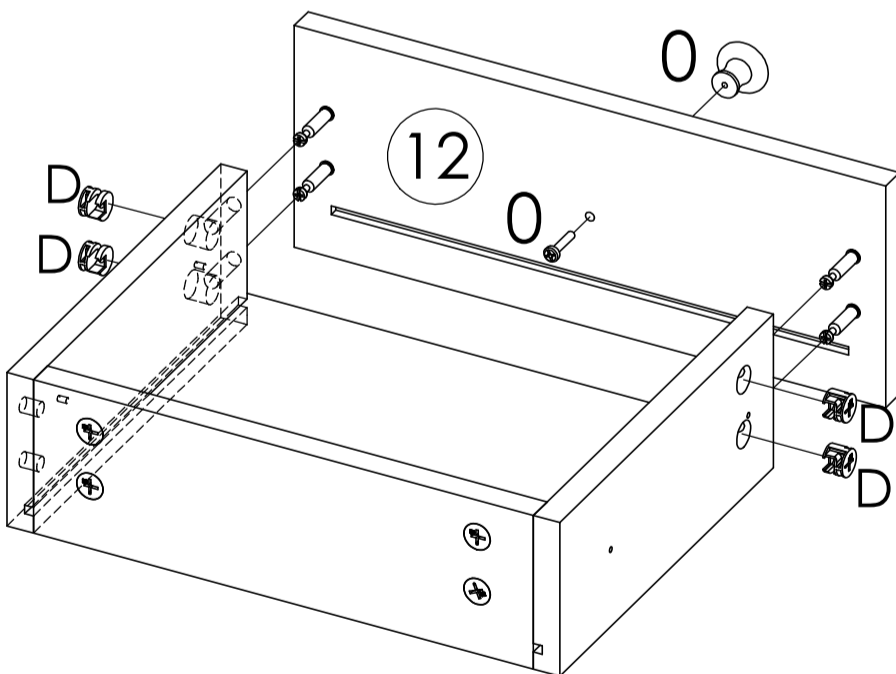

D X 4
0 X 1

STEP 9

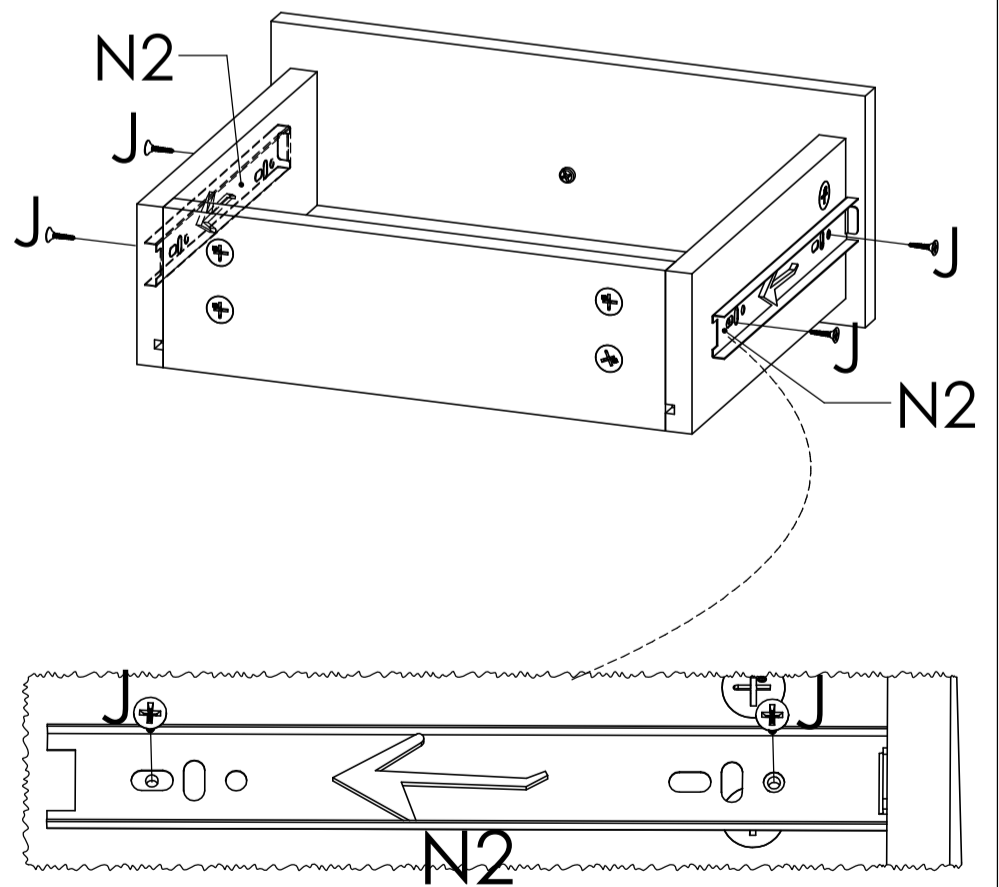

J X 4
N2 X 2

STEP 10

Note that the round holes on the bottom plate and the square holes on the side plate are on the same side

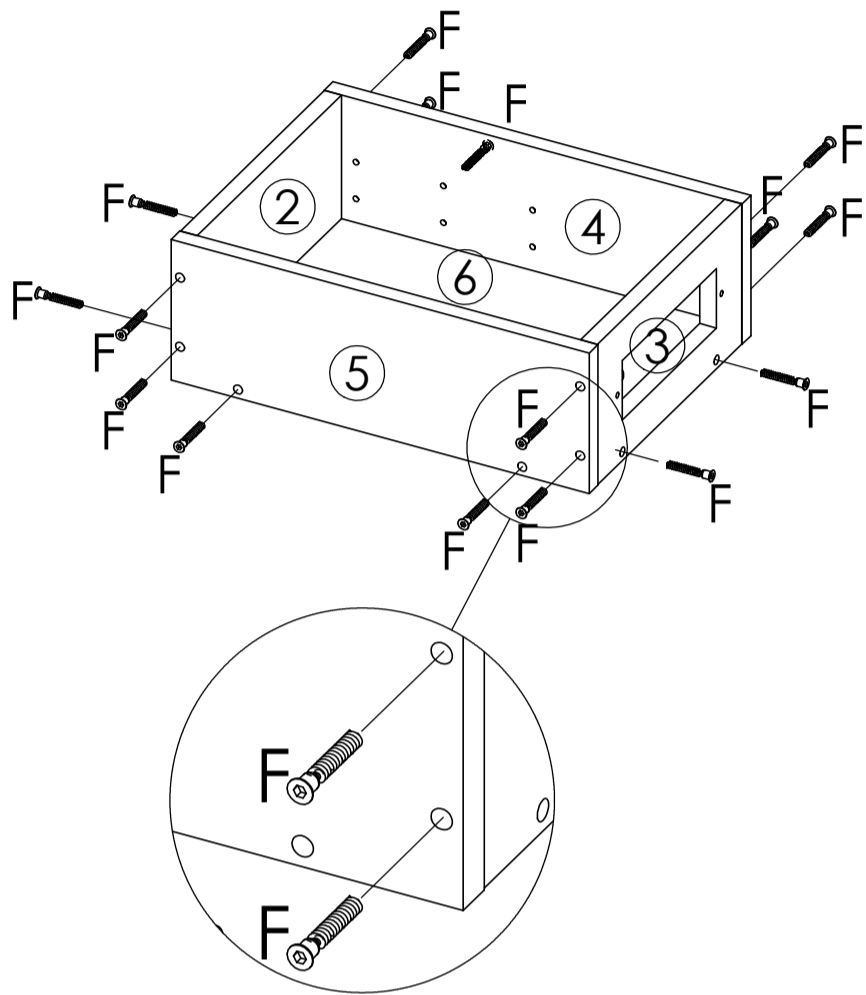

FX 16

STEP 11

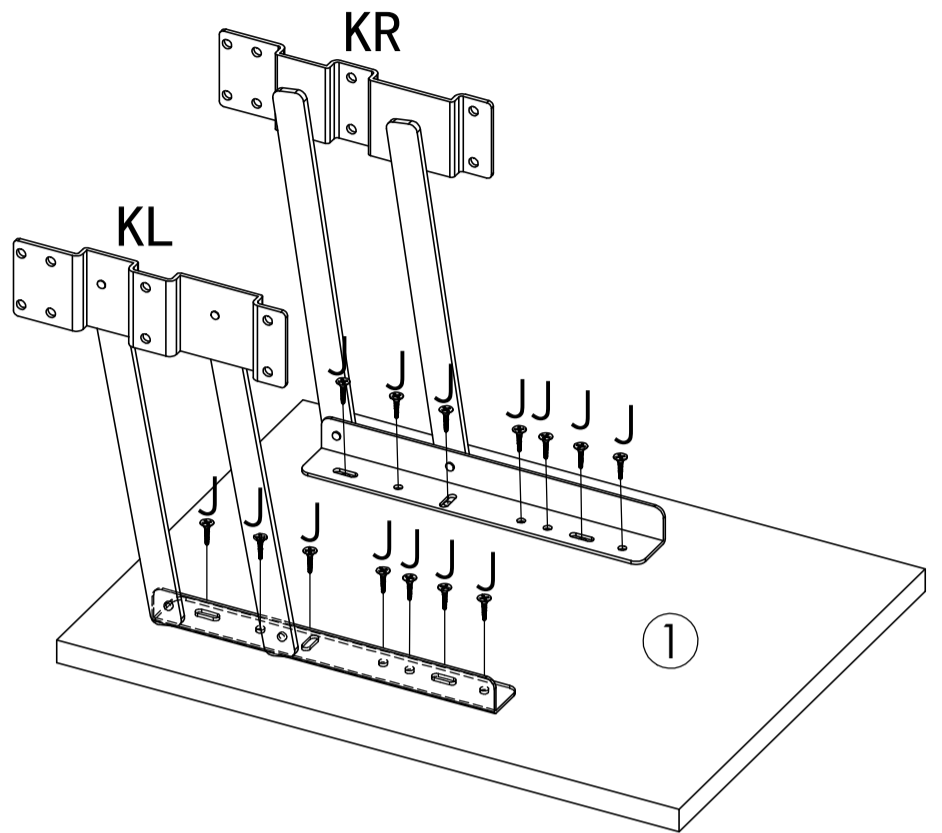

JX 14

STEP 12

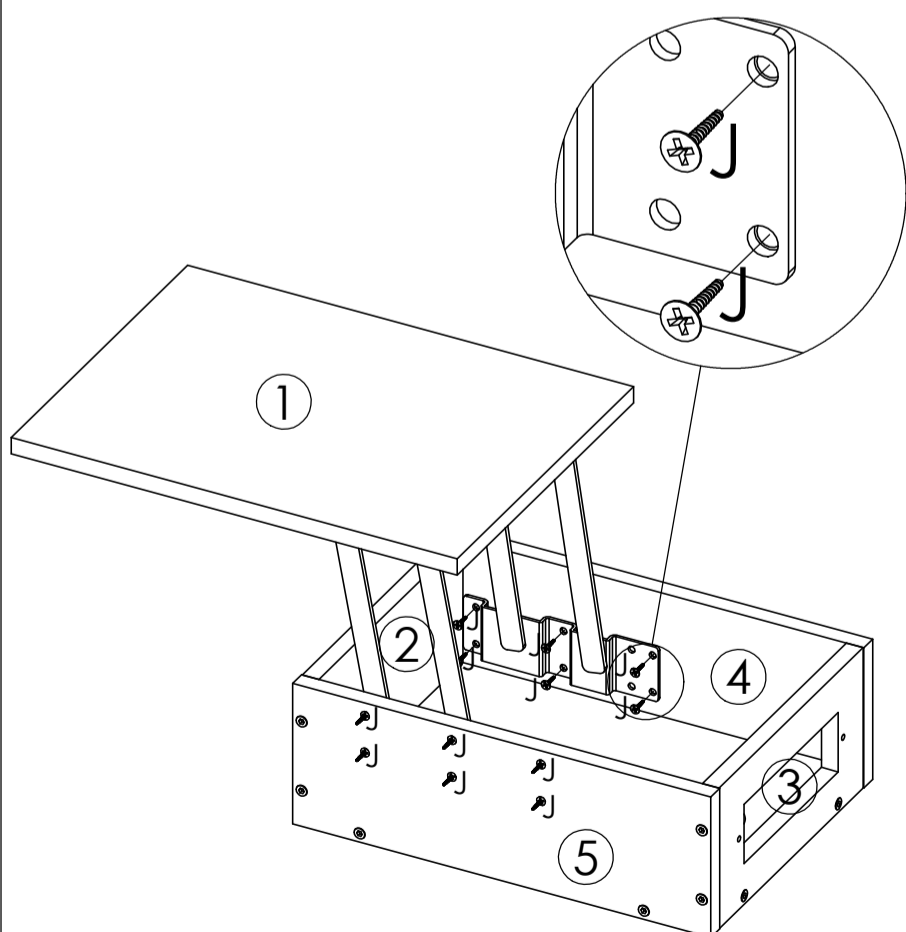

JX 12

STEP 13

Gently tighten the screws 80%

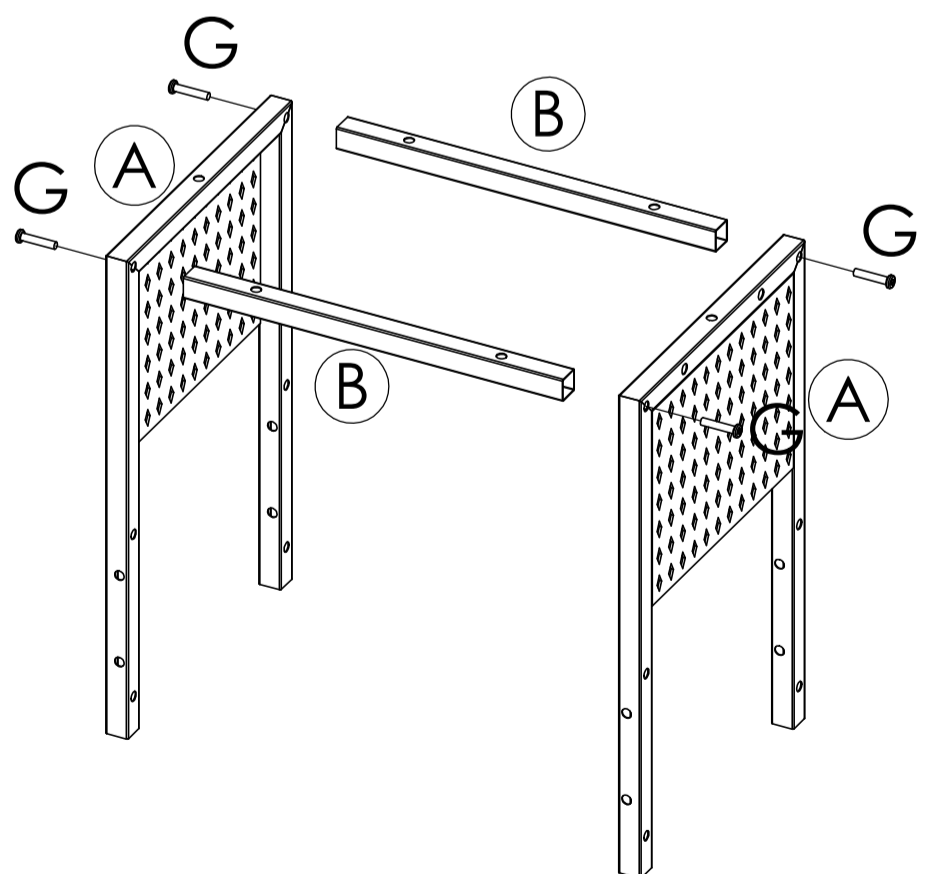

GX 4

STEP 14

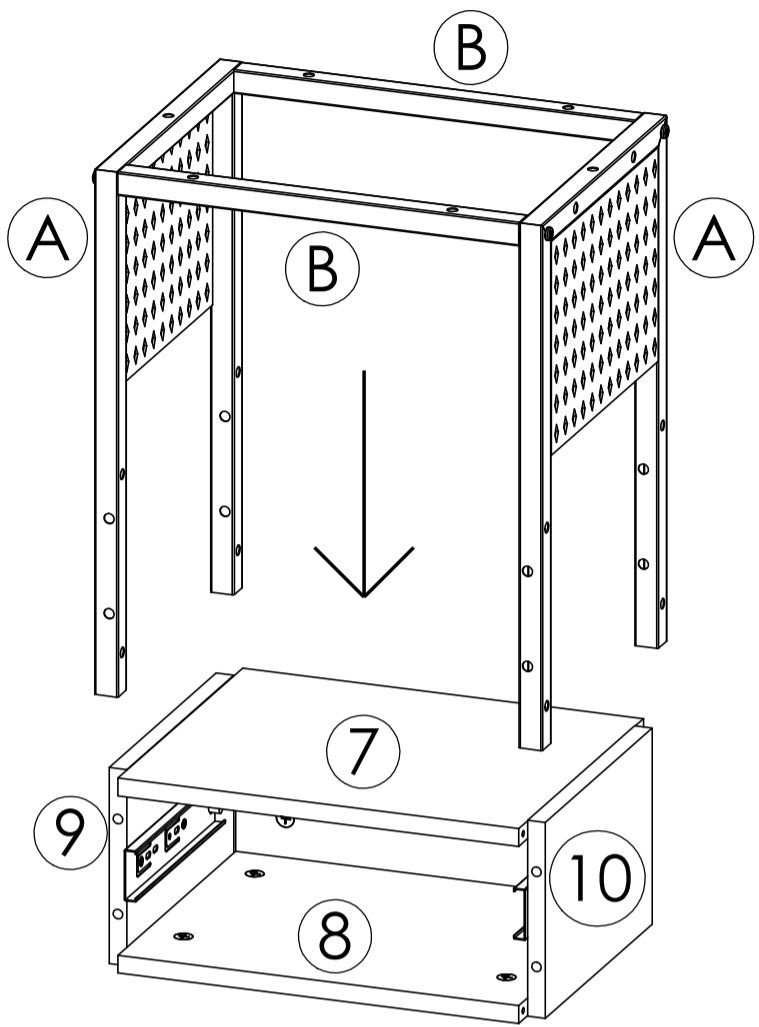

STEP 15

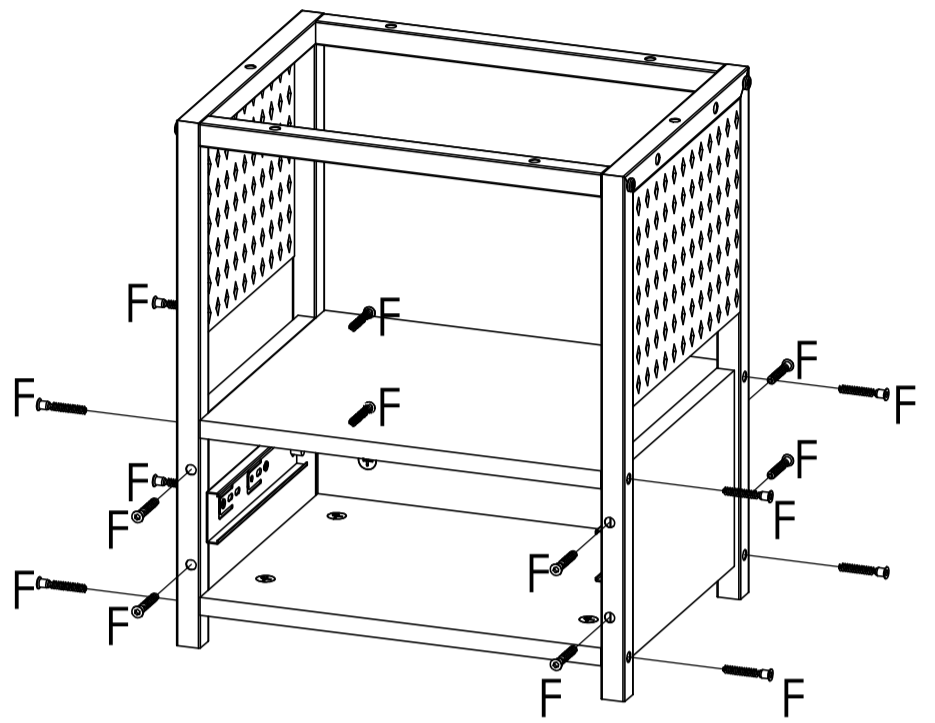

FX 16

STEP 16

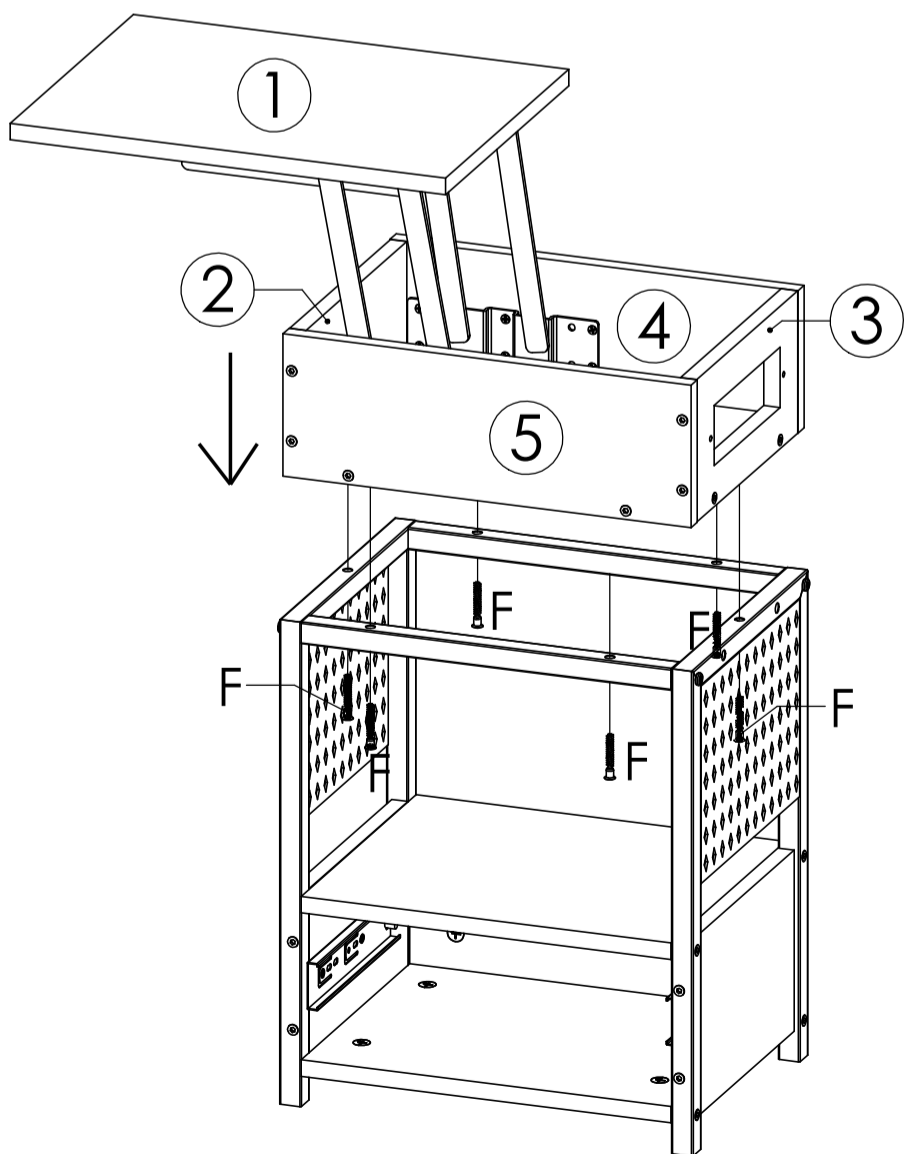

FX 6

STEP 17

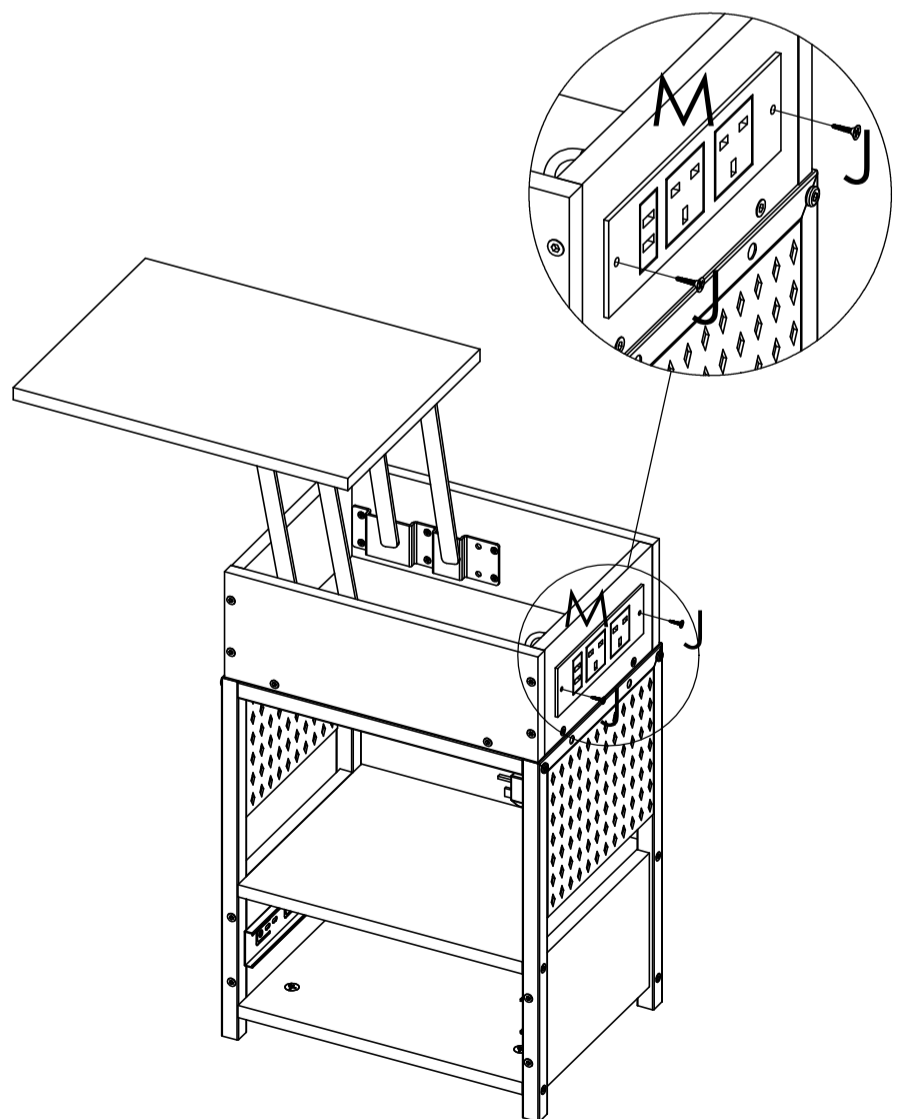

JX 2

STEP 18

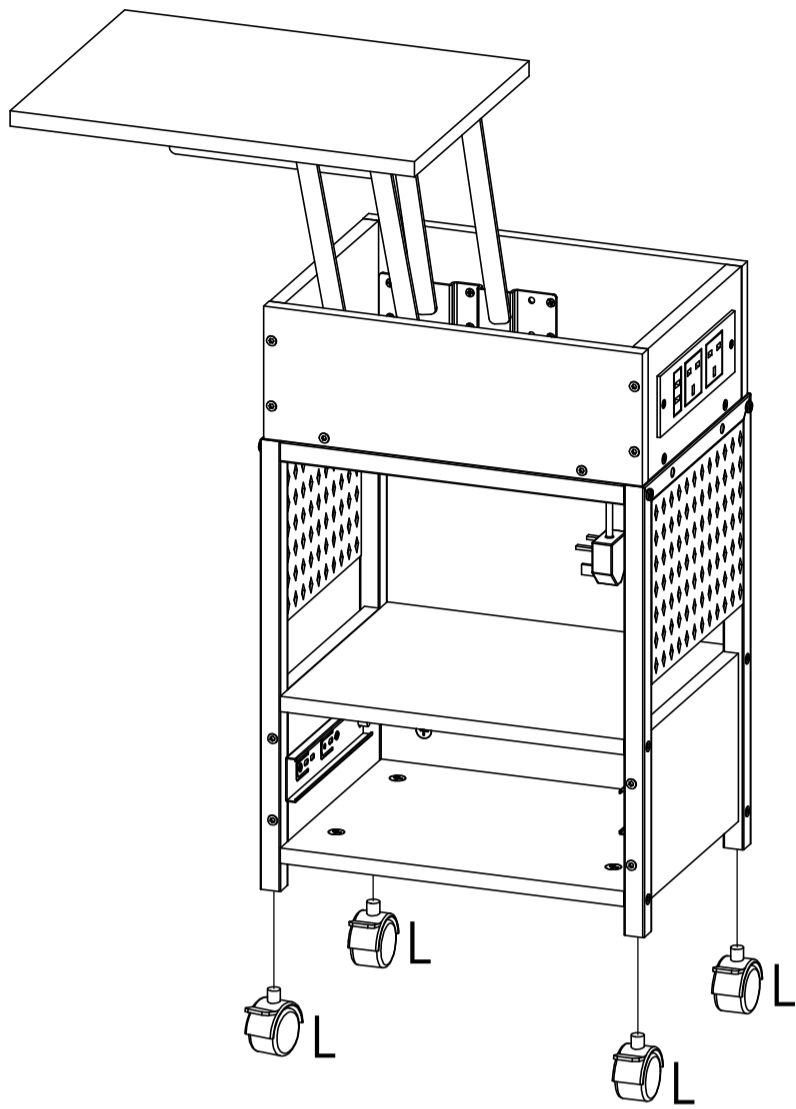

L X 4

STEP 19

1. Please tighten all the screws on the iron frame
2. Install the cloth bag on one side according to your usage habits

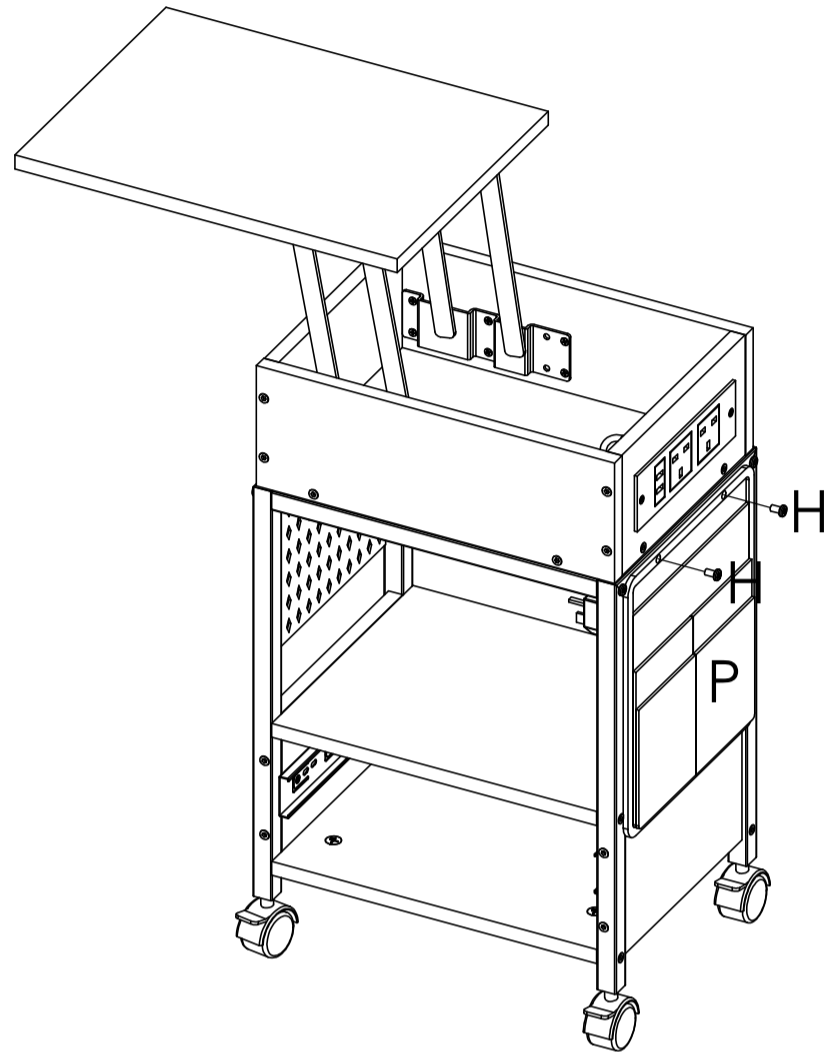

H X 2

STEP 20

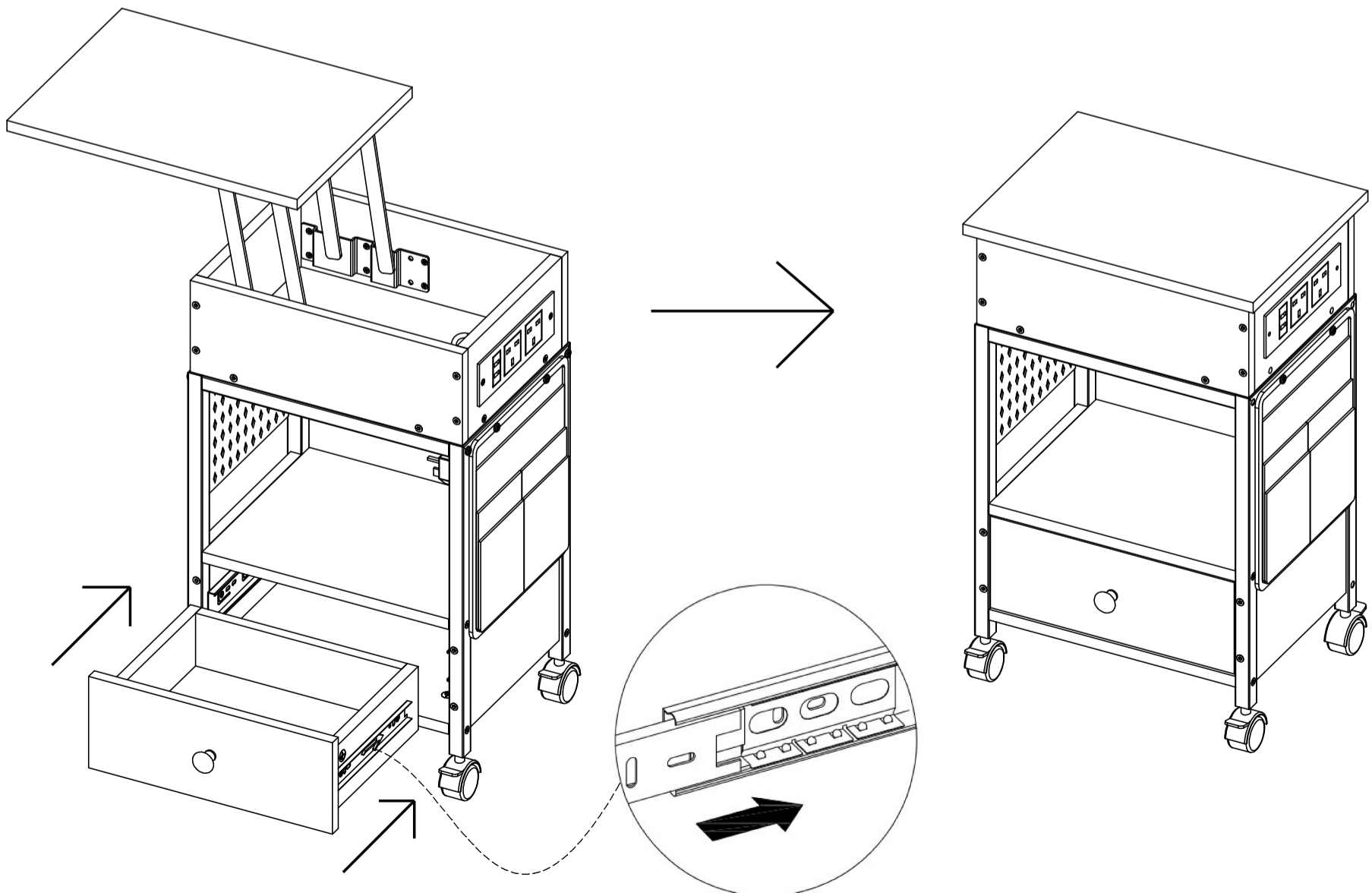



Frequently Asked Questions

1 I received a damaged package.

When you receive a damaged box, please open this package and check if there are any damaged or missing components inside the box. If so, please provide pictures and contact us through the platform. We will promptly resolve your issue.

2 I received the wrong color or product, which is not what I ordered.

When you receive a damaged box, please open this package and check if there are any damaged or missing components inside the box. If so, please provide pictures and contact us through the platform. We will promptly resolve your issue.

- the item No. on the package.
- the shipping label on the package.
- the actual item you received.

3 My order is incomplete.

Normally, we will send you 1, 2 or 3... packages according to your order. If product you received is incomplete, please contact us to update other package information to you. Missing parts should be reported within 48 hours after delivery. Please email us a description. Once the email and photos have been received, we will contact you to send out spare parts.

4 My item is faulty.

If your item is faulty, please provide us with some pictures or videos (if the box is also damaged) through the platform, and we will provide a solution after receiving your pictures. We do our best to make sure all orders arrive in perfect condition. In the rare event that it does not, our customer services team is here to help.



Return & Refund

While we hope you'll be happy with Furniture items, if sometimes you need to return them. This policy has all the information you'll need to know.

1. How to cancel my order?

If you wish to cancel your order for any reason, please contact us immediately. Only orders that have not yet been dispatched can be canceled. If the order has already been dispatched we will not be able to cancel at the platform and the below policy will apply.

2. How do I make a return?

If you wish to return an item that is no problem. We're happy to offer a refund or an exchange, as long as it's within the return period. You must return the item(S) to us within 30 days of receiving your order. To make the return process as quick and smooth as possible, please follow the below steps:

- a. Contact us by email within 30 days of your delivery to let us know you would like to return or exchange as well as why you would like to do so. We will solve the problem for you then.
- b. Make sure the item your order is in the original boxes. If you have not kept the original boxes, it is your responsibility to make sure the products are re-boxed, we do not provide additional boxes. Items must not have been used or assembled in any way. Please include the return slip in the box or write your order number on the outside.

3. Receiving your refund

When we reach a consensus, we will refund the money to the same way you paid for the product.

Please allow up to 5-14 working days for the refund to show in your account, which is the time for the bank to operate the refund.



General Care & Maintenance

Your furniture, if treated with respect and love, will last you a long time.
Each piece requires light maintenance to maximize its longevity.

Few quick tips before using this product:

- 1 Recommended weight limit for the table top is 301bs and 251bs for each storage compartment.
- 2 Avoid uneven weight distribution for long time as it may cause damage to the product shape.
- 3 Table top may not slide smoothly when table is overloaded by weight.
- 4 Check and tighten the cam lock and screw periodically as it may loose over the time.

How to take care of it?

- 1 Avoid direct sunlight or use curtains or blinds to limit the sun exposure to the product.
- 2 Clean the product regularly with a dry, soft cloth.
- 3 Avoid placing hot objects onto the table top surface.
- 5 Spillage may damage the surface. Clean immediately with a dry cloth
- 6 We recommend using placemats or coasters underneath glasses, cups, bowls or plates to prevent scratches to the table surface.

NOTES:

When moving your product, carefully lift into place. Never drag or push the product across the floor as this will cause damage to the joints. If the product is used on hard flooring, such as wood or laminated floor, you must place some protection under the legs to stop the product from moving. If this is not adhered to, it could result in failure to the product that will invalidate the warranty.