

Before You Start

- ⚠ Please read all instructions carefully.
- ⚠ Retain instructions for future reference.
- ⚠ Separate and count all parts and hardware.
- ⚠ Read through each step carefully and follow the proper order.
- ⚠ We recommend that, where possible, all items are assembled near to the area in which they will be placed in use, to avoid moving the product unnecessarily once assembled.
- ⚠ Always place the product on a flat, steady and stable surface.
- ⚠ Keep all small parts and packaging materials for this product away from babies and children as they potentially pose a serious choking hazard.

Important

When you open the cartons, carefully check the contents and make sure that there is no damage. If you have any problems or you find any parts damaged or missing, please contact us first.

Do not return the product to the store before contacting us. Do not dispose of your cartons until you are completely satisfied with your products.

To reduce the risk of injury, the user should read and understand this owner's manual before assembling and using these products for the first time.

Safety Guidelines

●WARNING

Need two or more people to move, assemble, and install the product to avoid any injury.

●WARNING

DO NOT leave children unattended near the product.

●WARNING

DO NOT stand on the product or lean on the drawers or worktop.

●WARNING

WEAR SAFETY GLASSES when removing or repositioning the slides. The tools could slip, which may cause personal injury.

●WARNING

DO NOT alter the product in any manner. For example, do not weld external lock bars or attach unapproved electrical equipment. This may cause product damage, personal injury, or death.

●WARNING

DO NOT OVERLOAD PRODUCTS! The product has a maximum weight capacity of 220lbs(100kg).

●CAUTION

BE CAREFUL when opening more than one drawer. The product could become unstable and may tip, which may cause product damage or personal injury.

●CAUTION

High risk of tipping if the product is not installed correctly. Securely attach the product to the wall to avoid serious injury.

Unpacking

1. Please make sure that you have received all your packages for this product.

2. Start by placing the package on flat covered ground.
3. Remove all cardboard, honey comb board, foam packaging material and clear plastic bags.
4. Recycle all packaging materials.
5. Verify that all the contents are included and gather the tools required.

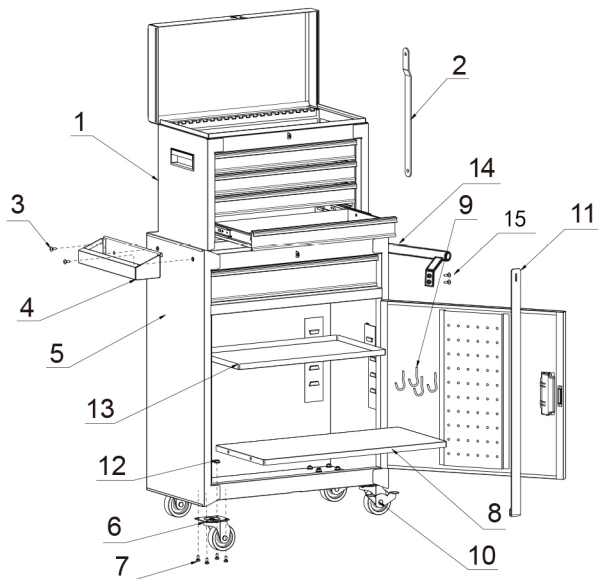

Attention: The shelf (8) is under the top chest in transportation

Parts List

No.	Description	Qty
1	Top chest	1
2	Short lock bar	1
3	M6x12 bolt	2
4	Tool holder	1
5	Bottom cabinet	1
6	Swivel caster without brake	2
7	M6x12 bolt	16
8	Shelf	1
9	Hook	4
10	Swivel caster with brake	2
11	Long lock bar	1
12	M6 nut	16
13	Fixing Plate (Discard it after taking out)	1
14	Hand I e	1
15	M6x12 bolt	4

STEP 1

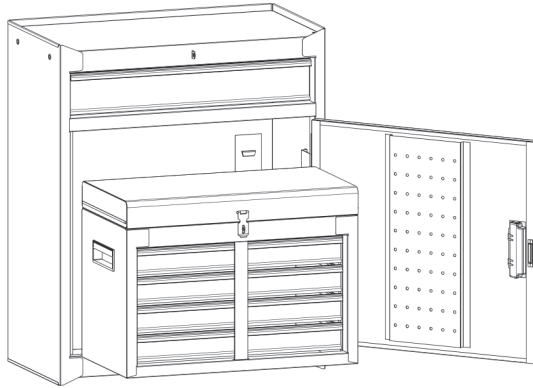

Remove the carton

Open the carton, place the cabinet on a level surface.

Get the cabinet from the carton. (Attention: The top chest is inside the roller cabinet)

STEP 2

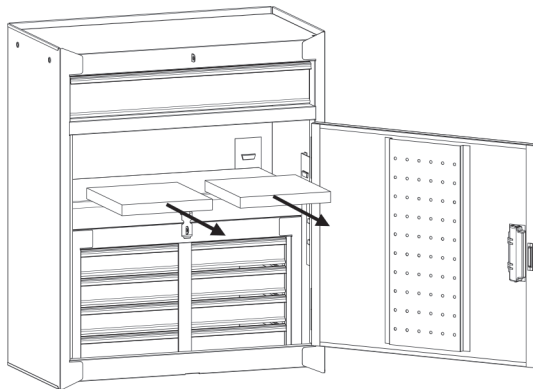

Remove the foam

Open the cabinet to remove the foam.

STEP 3

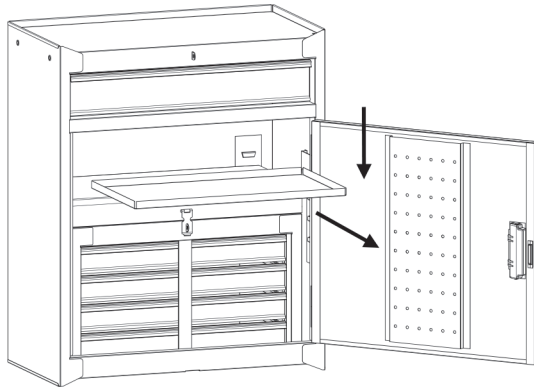

Remove the fixing plate

After removing the foam, press down the fixing plate and take it out from the cabinet. (Attention: The plate is used to fix the top chest, please discard it after taking out.)

STEP 4

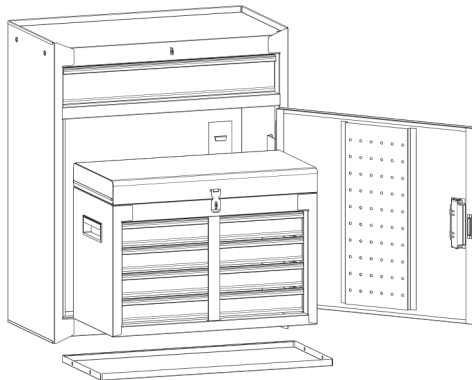

The shelf (8) is under the top chest in transportation

Get the top chest and shelf

After removing the fixing plate, take out the top chest and shelf from the cabinet. (Attention: The shelf is under the top chest)

STEP 5

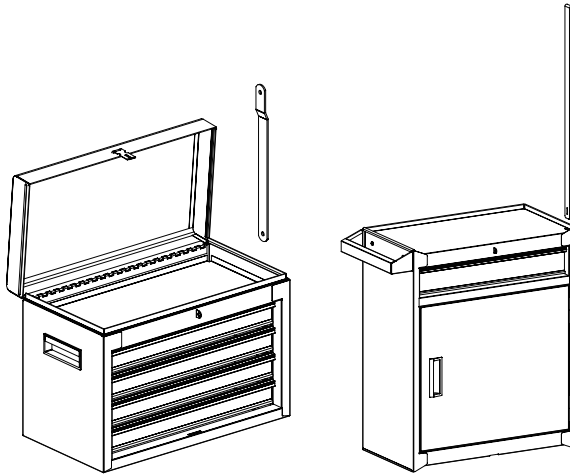

Lock Bar

Hide the lock bar when you don't need them.

STEP 6

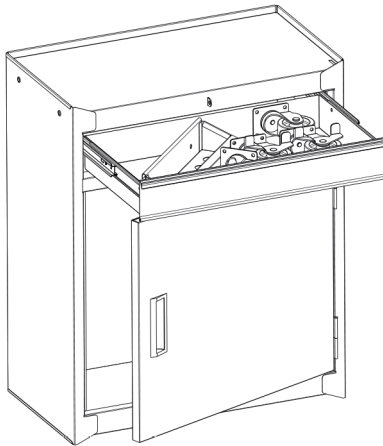

Get the parts

Open the drawer to take out the tool holder and caster box.

STEP 7

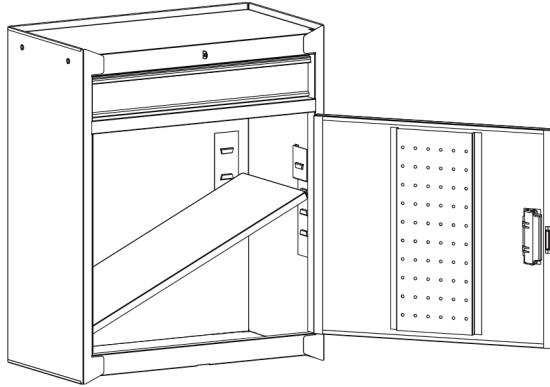

Shelf Assembly

Put the shelf (8) into the slot of roller cabinet.

STEP 8

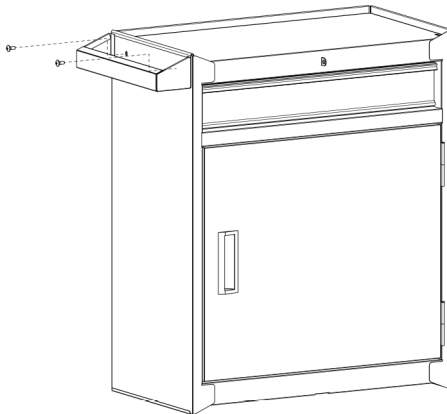

Tool Holder Assembly

Use M6x12 bolts (3) to assemble the tool holder with a screwdriver.

STEP 9

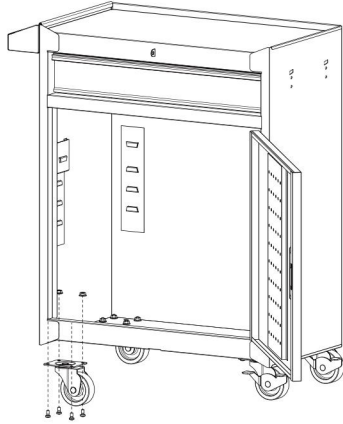

Caster Assembly

Use M6x12 bolts (7) with M6 nuts(12) to assemble the casters. We recommend to put the casters with brakes on the right side.

STEP 10

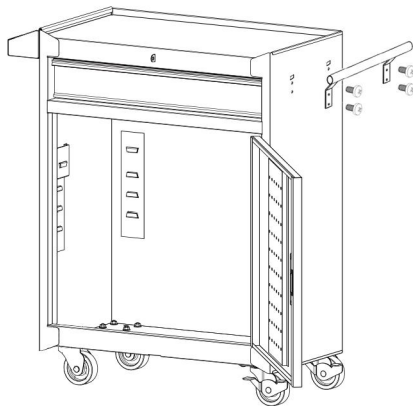

Handle Assembly

Use M6x12 bolts (15) to assemble the Handle with a screwdriver.

Maintenance

1. Periodically clean the work bench with mild detergent and water.
2. For safety, use a non-flammable cleaning fluid. Grease and oil can be removed with most standard cleaning fluids.
3. Do NOT allow water and other fluids to remain on the work bench for any length of time.
4. DO NOT OVERLOAD! The product has a maximum weight capacity of 220lbs(100kg).



Return / Damage Claim Instructions

- ⚠ **DO NOT discard the box / original packaging.**
In case a return is required, the item must be returned in original box. Without this your return will not be accepted.
- ⚠ **Take a photo of the box markings.**
A photo of the markings (text) on the side of the box is required in case a part is needed for replacement. This helps our staff identify your product number to ensure you receive the correct parts.
- ⚠ **Take a photo of the damaged part (if applicable).**
A photo of the damage is always required to file a claim and get your replacement or refund processed quickly. Please make sure you have the box even if it is damaged.
- ⚠ **Send us an email with the images requested.**
Email us directly from marketplace where your item was purchased with the attached images and a description of your claim.