

**BERLIN
GARDENS**

Comfo Back Single & Double Counter Height Gliders Assembly Guide

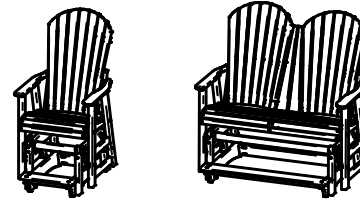

Tools Required

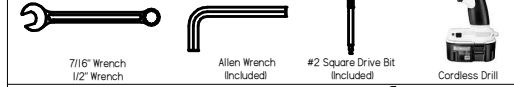

Hardware Included

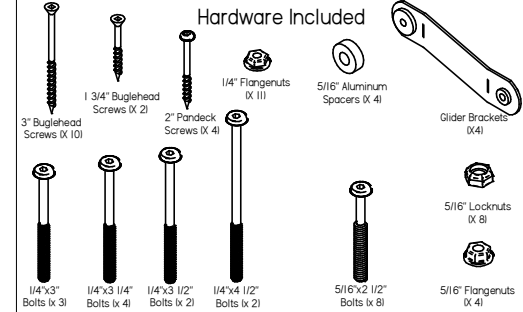

Glider Chair

Step 1

Fasten the Arm & Leg Assembly to the Seat and Back using the bolts and nuts specified below.

Note: The example shows a double glider. The single glider is same except for one less bolt & nut as indicated.

Please assembly your glider on a soft surface to avoid scratching the material.

Step 2

Turn the chair on the other side and fasten the second Arm & Leg Assembly by repeating step 1.

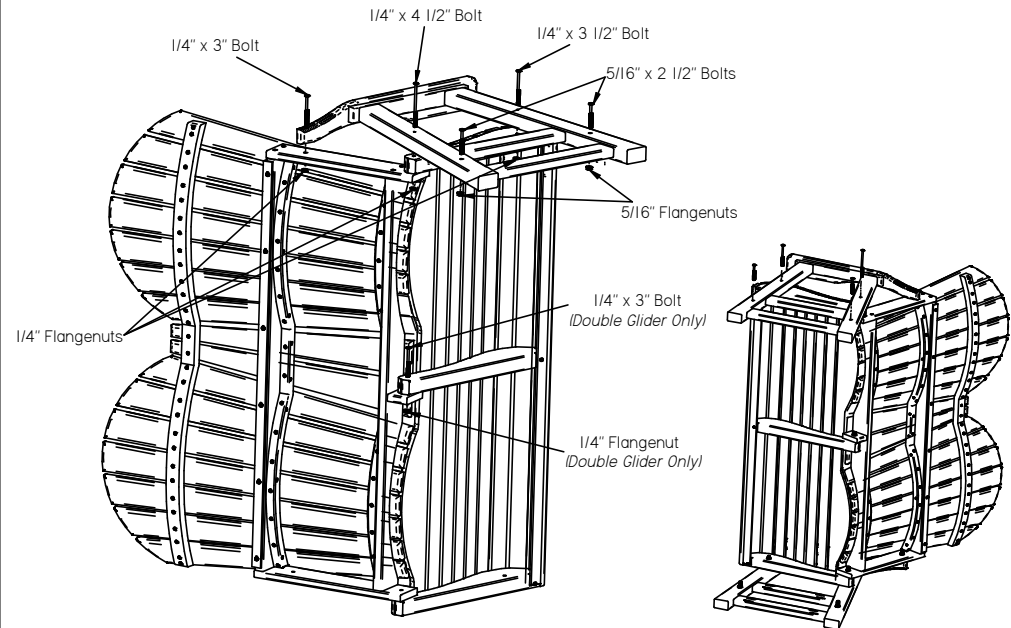

Step 1

A
Fasten the Back Cross Piece to a Base Side Assembly by fitting the mortise & tenon together and driving two - 2" Pandeck Screws into the pocket holes as shown. The pocket holes are to be turned inward.

B
Position the footrest into the small cutout in the top, front of the base side. Fasten it using one - 3" Buglehead Screws and one - 1 3/4" Buglehead Screws.

Note: On a double glider, the aluminum support piece should be turned inward.

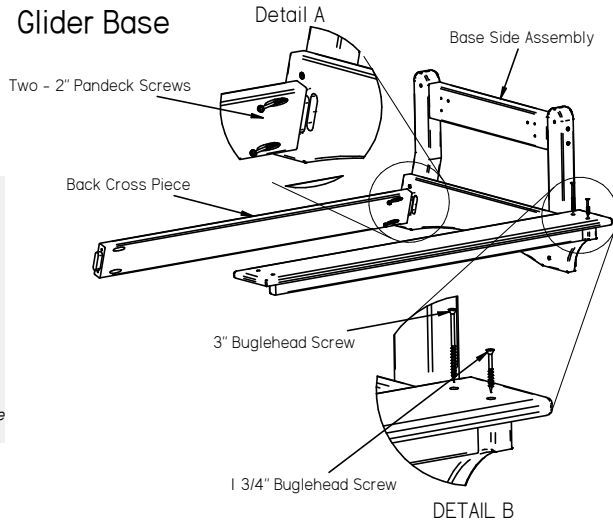

Step 2

Repeat Step 1 (above) to attach the second Base Side Assembly.

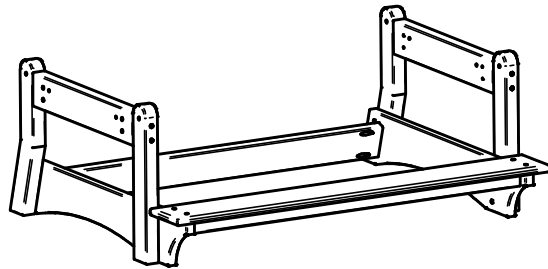

Step 3

Fasten both Top Cross Pieces by driving eight - 3" Buglehead Screws through the countersink holes in the Base Side Assemblies and into the predrilled holes in the ends of the Top Cross Pieces.

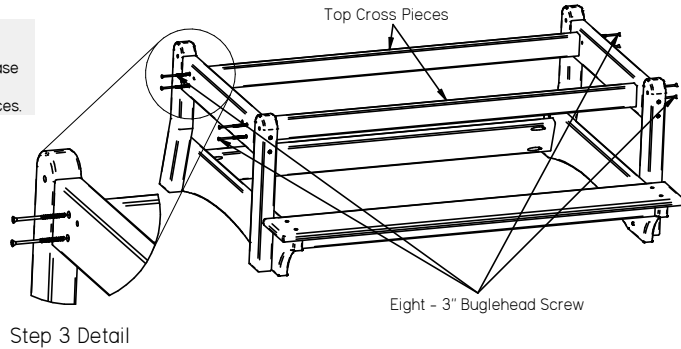

Step 4

Attach the four Glider Stops to the Base using four - 1/4" x 3 1/4" Bolts and four - 1/4" Flangenuts. Insert the bolts through the Glider Stops and into the predrilled holes in the base. Be sure to firmly fasten.

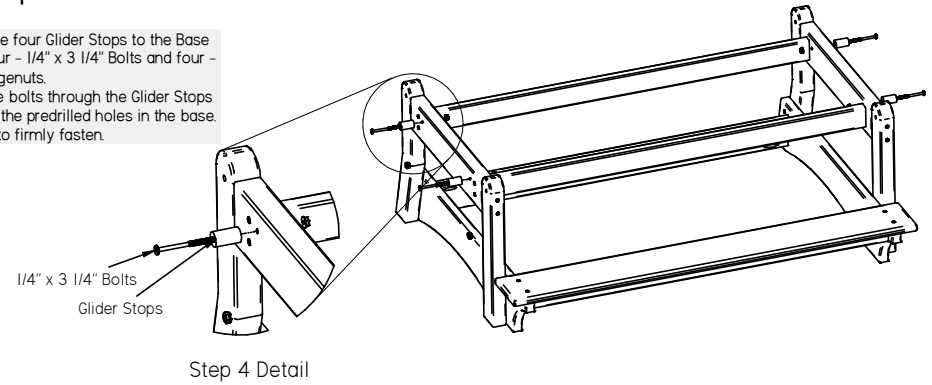

Step 5

Install the Glider Brackets using following sequence. First slide the Glider Bracket onto the 5/16" x 2 1/2" Bolt. Secondly slide the round 5/16" Aluminum Spacer onto the bolt, positioning it beside the glider bracket. Insert the bolt into the predrilled holes in the glider base. Firmly tighten with the 5/16" Lock Nut. Repeat this step for all four glider brackets.

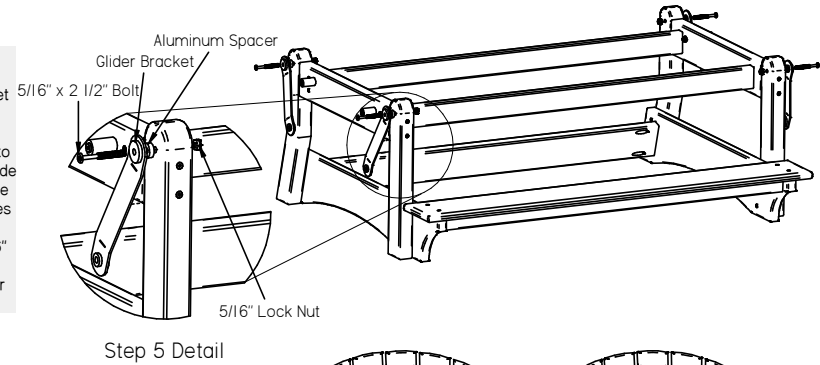

Step 6

Slide the Glider Base Assembly underneath the Glider Chair ensuring that the footrest is forward. Lift chair until you can slide the Glider Brackets onto the 5/16" x 2 1/2" Bolts that are installed in the lower part of the legs. Using four - 5/16" Locknuts, secure the brackets onto the bolts and against the flangenuts that were already installed. Repeat this process for each of the four glider brackets.

