

ASSEMBLY INSTRUCTIONS

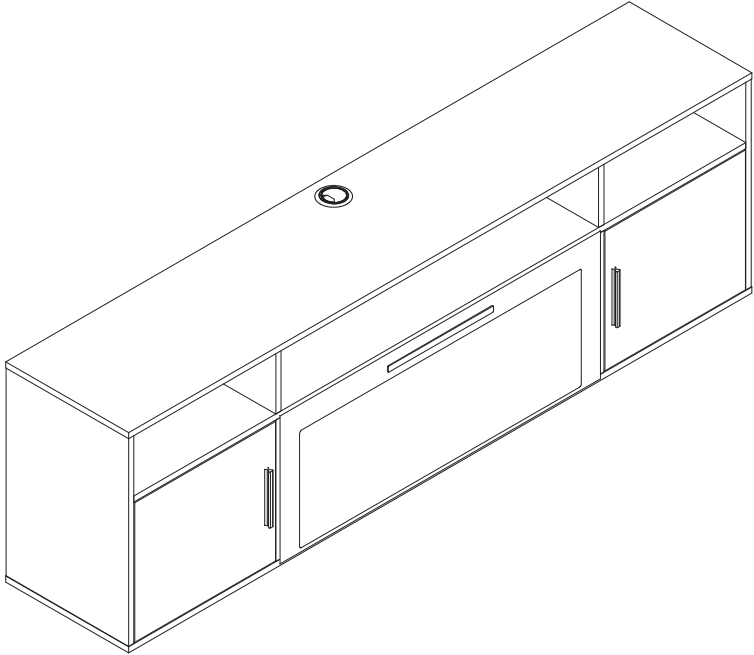

Attention: The Fireplace and TV stand come in **TWO PACKAGES**
Please don't be confused if only one package was received.

The light strip comes with fireplace. It should be installed
after **TWO PACKAGES** received.

HOPE YOU HAVE A PERFECT SHOPPING EXPERIENCE!

Our product is designed with excellence crafted from premium materials, and exhibits a unique sense of style. Every detail has been thoughtfully considered to bring both elegance and functionality to your space.

Whether in the office or at home, our product offers long-lasting performance and versatile use. We believe it will enhance your environment and make your daily tasks easier.

If you encounter any issues or have questions, please don't hesitate to contact our dedicated customer service team. We are always here to assist and ensure your satisfaction.



IMPORTANT SAFETY INSTRUCTIONS



Read these instructions carefully and retain them for future use.

When using the product, basic safety precautions always be followed to reduce the risk of injury including the following:

- Before installing, please carefully read the installation manual.
- This product must be assembled by adults.
- Keep children and pets away while assembling the product, prevent accidental ingestion of parts.
- Always use the product on a firm, level ground.
- Please do not use an electric screwdriver to assemble the unit.
- Do not over-tighten the fasteners.
- Do not use this product if any parts are missing, damaged, or worn.
- Do not let the children climb on or play with the product.
- Regularly examine the product for wear and tear. Stop using the product at the first sign of damage or if the parts detached.



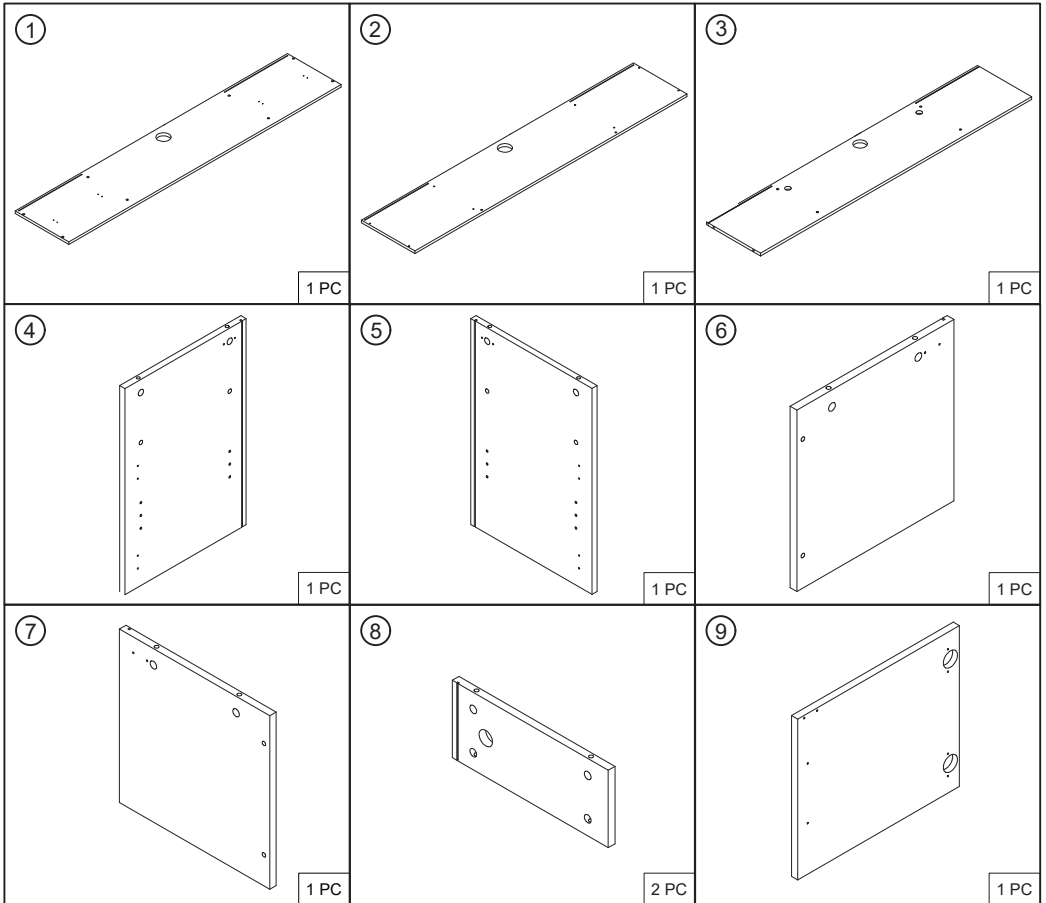

PARTS LIST

NOTICE



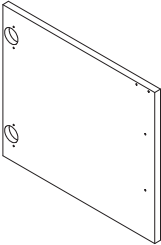
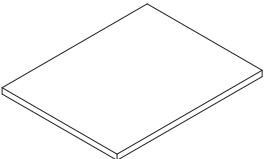





Please make sure all the parts are included. If there are parts missing, please feel free to contact our customer service team.

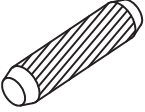

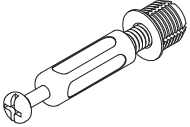
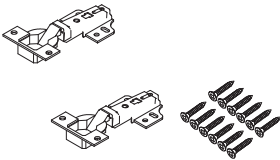
PARTS LIST

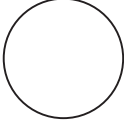
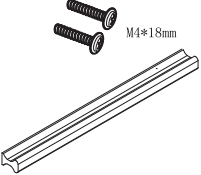
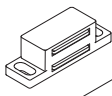
<p>⑩</p>  <p>1 PC</p>	<p>⑪</p>  <p>2 PC</p>	<p>⑫</p>  <p>2 PCS</p>
<p>⑬</p>  <p>2 PCS</p>	<p>⑭</p>  <p>2 PCS</p>	

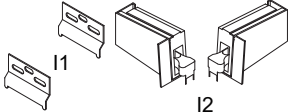
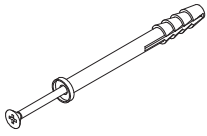
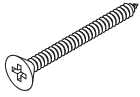
PARTS LIST

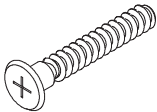
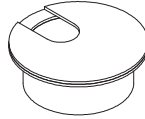
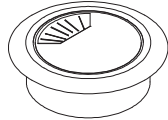
<p>A</p>  <p>ϕ 8*30mm</p> <p>8PCS</p>	<p>B</p>  <p>ϕ 15*12mm</p> <p>20+1PCS</p>	<p>C</p>  <p>ϕ 6*43mm</p> <p>20+1PCS</p>
<p>D</p>  <p>2PCS</p>	<p>E</p>  <p>8+1PCS</p>	<p>F</p>  <p>ϕ 20 Screw Hole Sticker</p> <p>12PCS</p>
<p>G</p>  <p>M4*18mm</p> <p>2PCS</p>	<p>H</p> <p>H1</p>  <p>H2</p>  <p>2PCS</p>	<p>I</p>  <p>I1</p> <p>I2</p> <p>2PCS</p>
<p>J</p>  <p>ϕ 8*80mm</p> <p>8PCS</p>	<p>K</p>  <p>K4*30mm</p> <p>8PCS</p>	<p>L</p>  <p>K3*14mm</p> <p>8+1PCS</p>
<p>M</p>  <p>M5*40mm</p> <p>8+1PCS</p>	<p>N</p>  <p>2PCS</p>	<p>O</p>  <p>3PCS</p>

INSTALLATION STEPS

NOTICE

Please feel free to contact us if you have any installation questions.

STEP 1

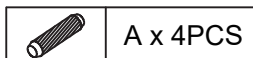

Use two A to connect 6 and 12,
then connect 7 and the
other 12 in the same way.

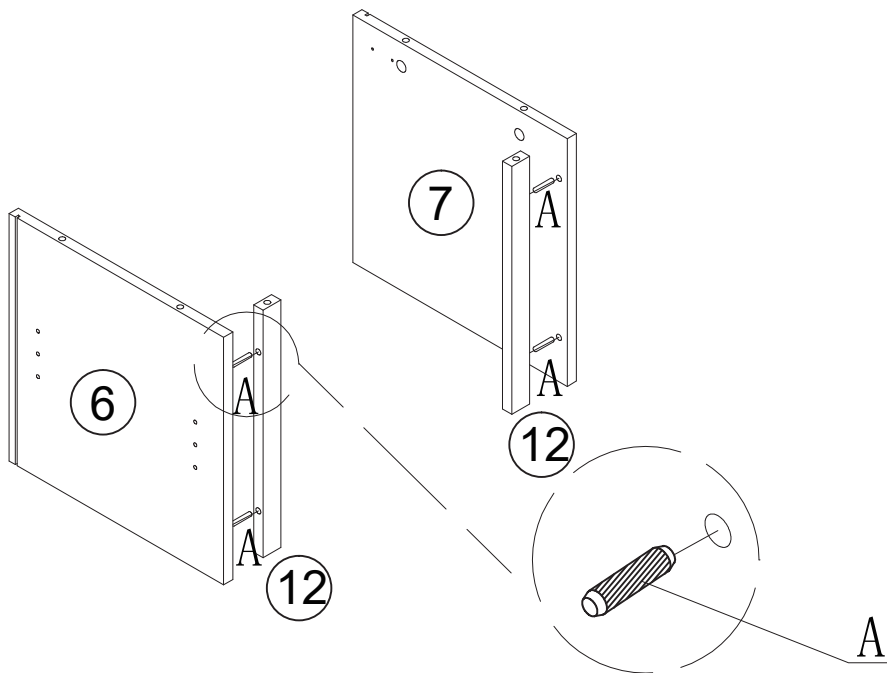

INSTALLATION STEPS

STEP 2



C x 4PCS

First press C vertically into the hole until the threads of the white plastic part are fully in, then tighten the screws clockwise. NOTE: If the white plastic doesn't press down, you can use a tool to gently knock it down.

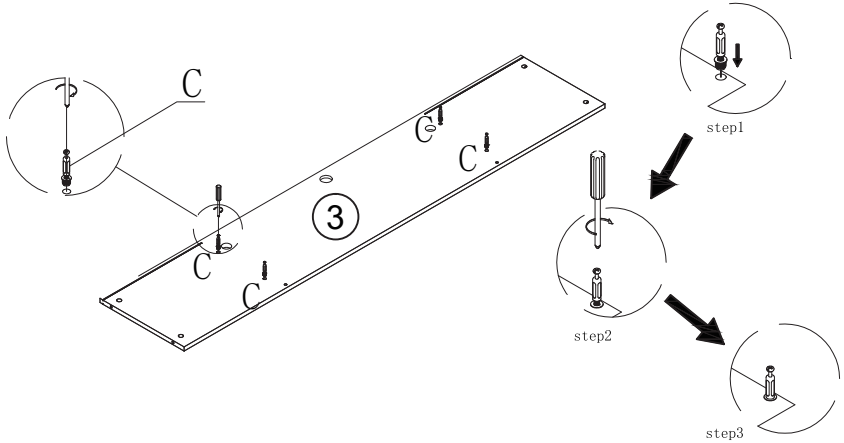

STEP 3



L x 4PCS



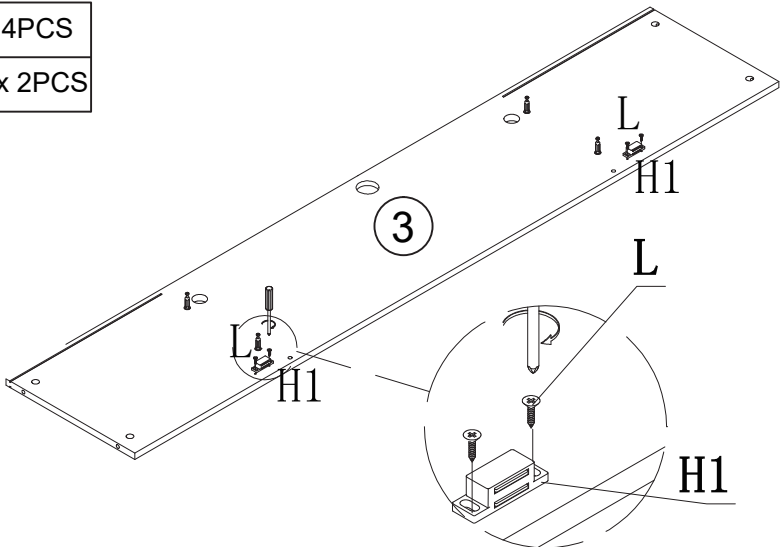

H1 x 2PCS



INSTALLATION STEPS

STEP 4

	A x 2PCS
	B x 4PCS

Please note the groove on Panel 3, Panel 7 and Panel 6 should be on same side.

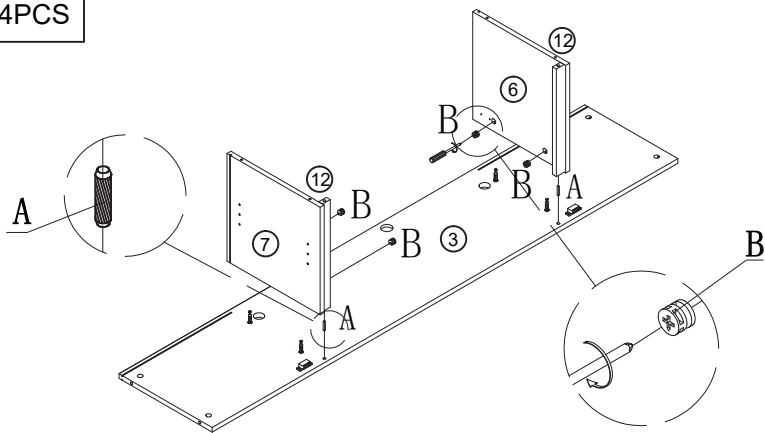

STEP 5

	C x 4PCS
--	----------

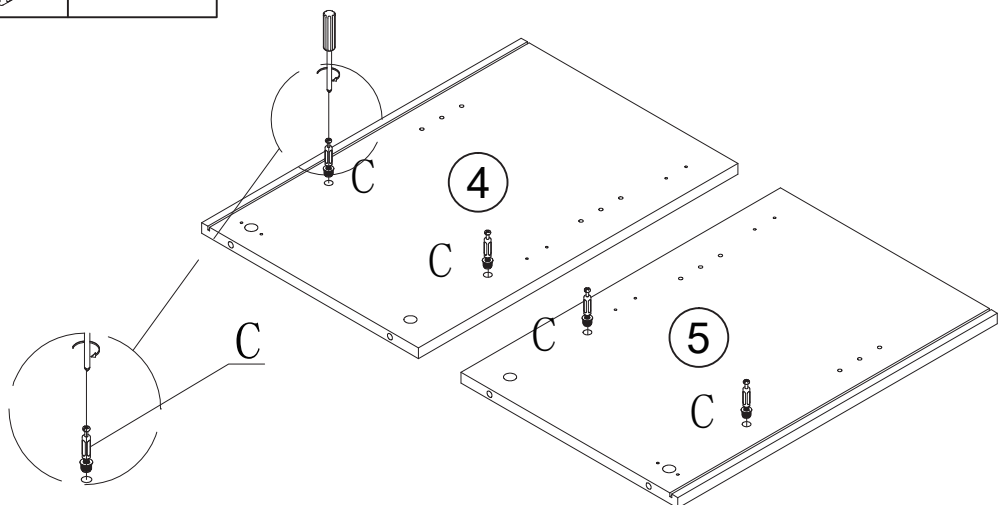

INSTALLATION STEPS

STEP 6



B x 4PCS

Use two B to connect 4 and 3,
then connect the 5 and 3
in the same way.

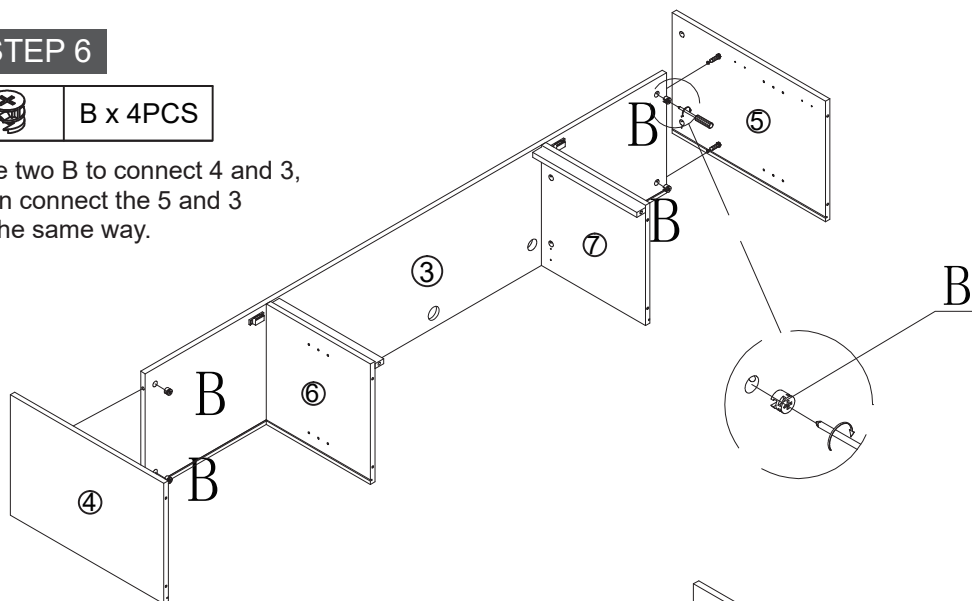

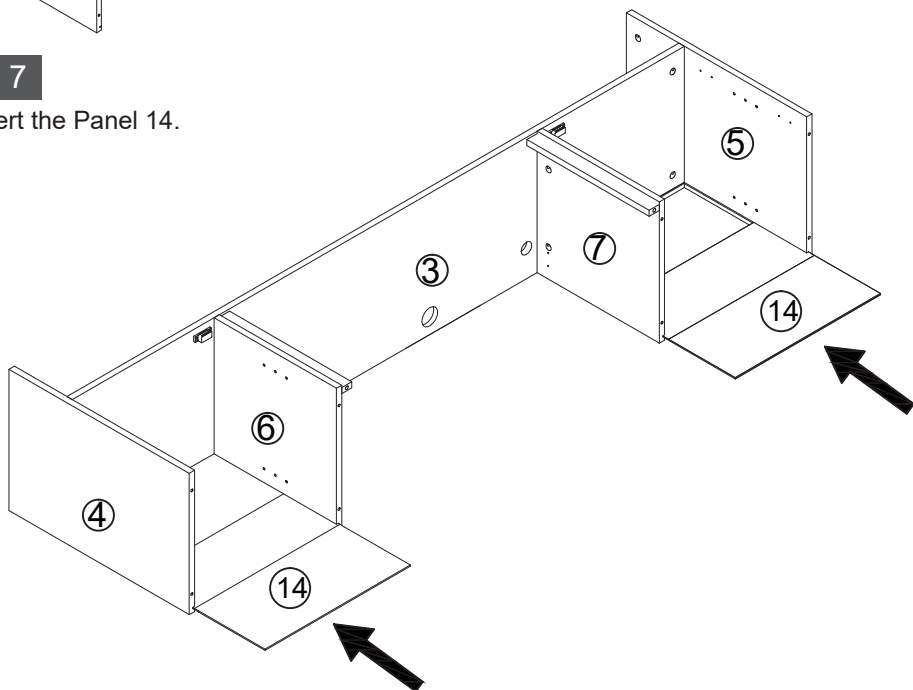

STEP 7

Fully insert the Panel 14.



INSTALLATION STEPS

STEP 8

	A x 2PCS
	M x 8PCS

Install the Wood Stick A for connecting the Panel 2 and main body first, then using Screw M for further connecting.

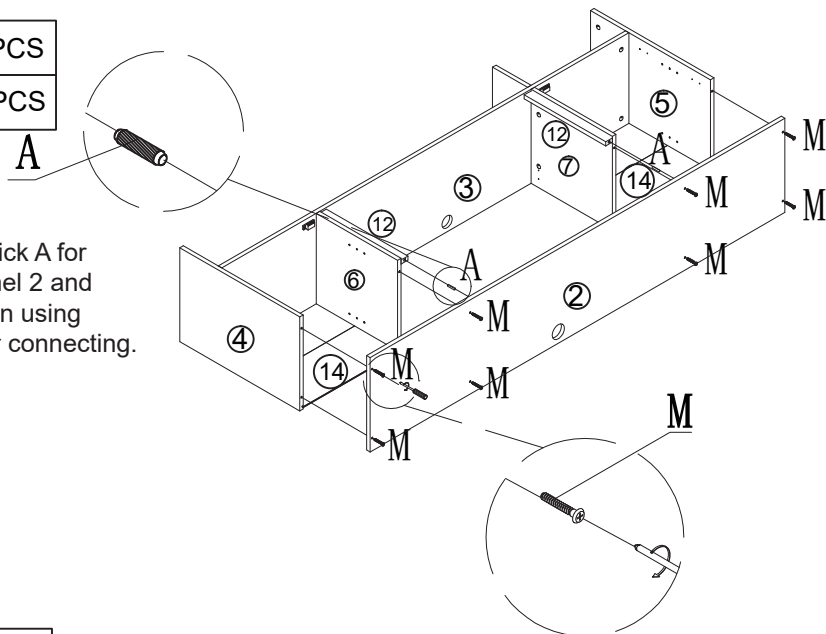

STEP 9

	C x 4PCS
--	----------

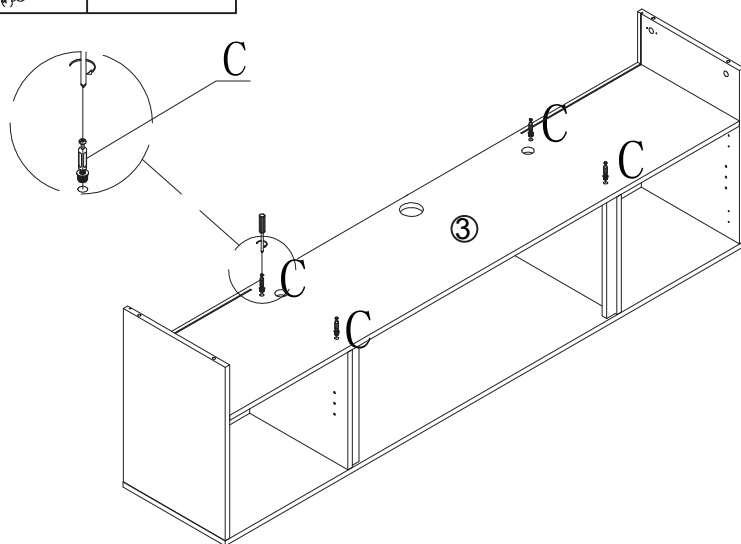

INSTALLATION STEPS

STEP 10



B x 4PCS

Please pay attention to the holes on the Panel 8 for confirming direction.

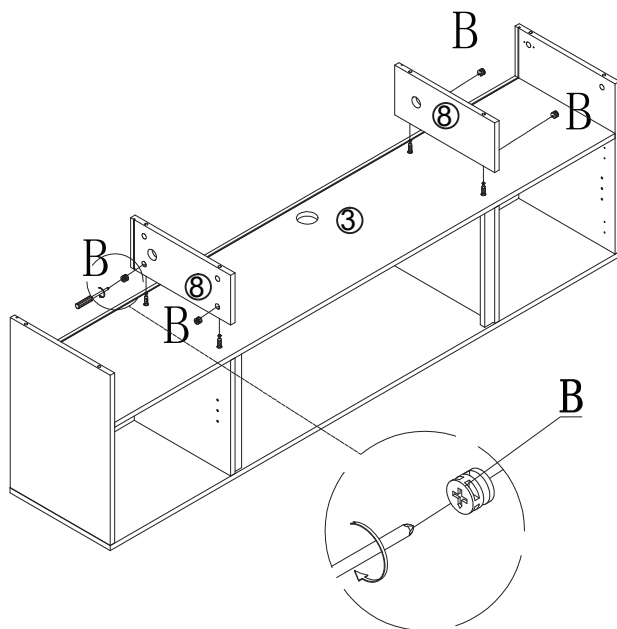

STEP 11

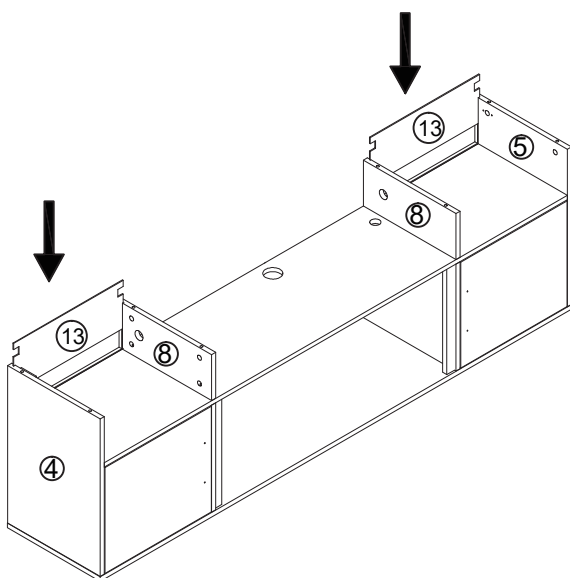

INSTALLATION STEPS

STEP 12



C x 8PCS

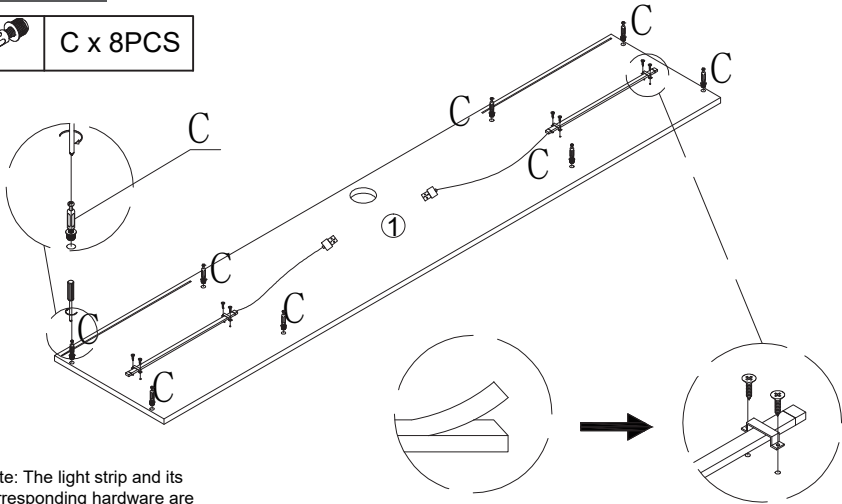

Note: The light strip and its corresponding hardware are included inside the fireplace packaging.

Peel off the adhesive backing of the light strip and stick it onto the board.

Use the clips to secure the light strip and tighten the screws.

STEP 13



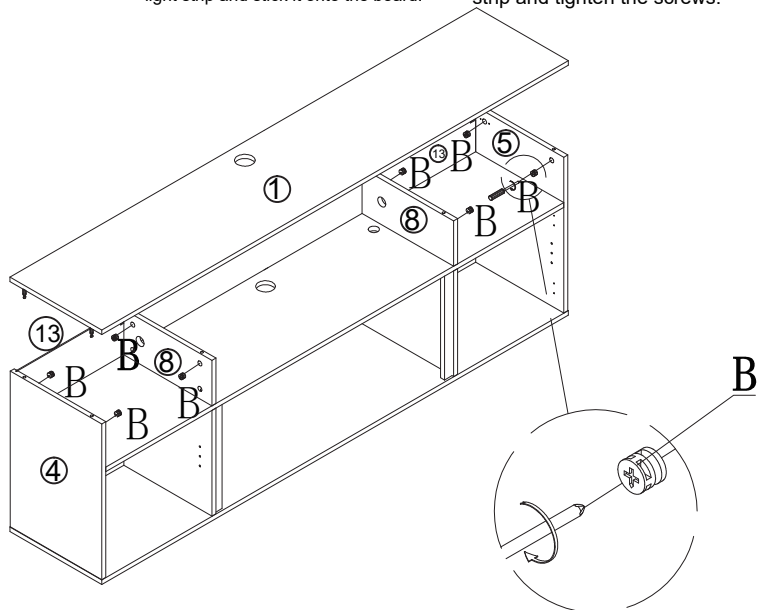

B x 8PCS



INSTALLATION STEPS

STEP 14

	I2x 2PCS
	K x 8PCS

Install I2 on the 4 5 6 7, noting that the hook on I2 face backwards. The ones marked L2 are mounted on 4 and 6, and the ones marked R2 are mounted on 5 and 7.

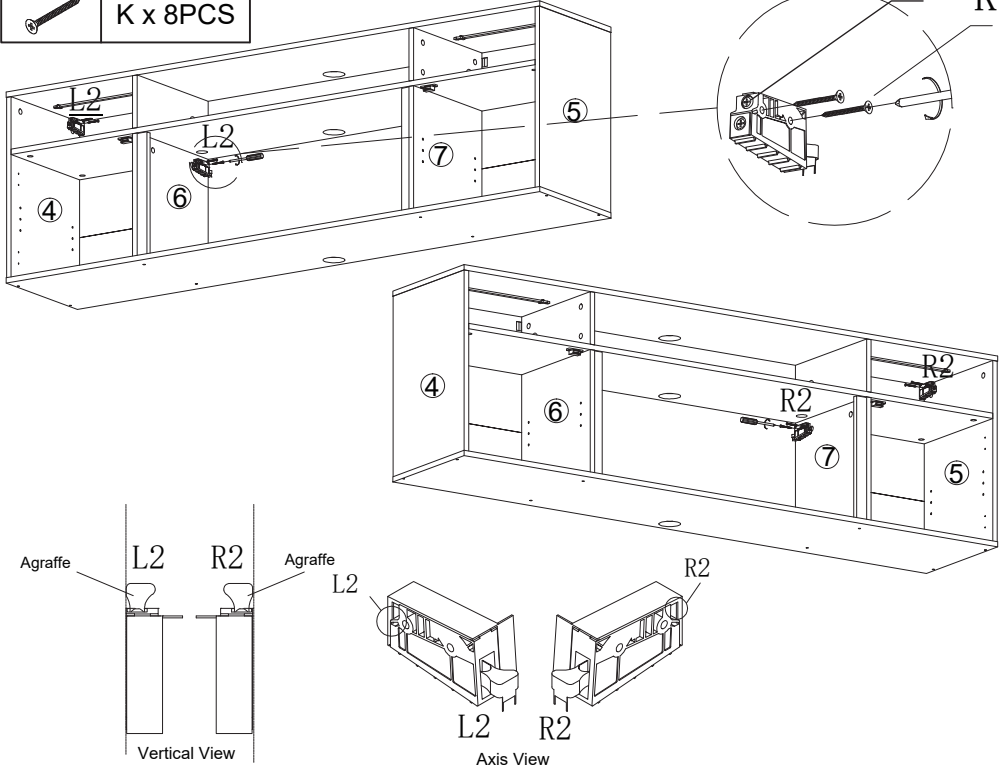

View of the white plastic cover before being removed. Method to distinguish left and right:

1. The text label L2 on the white plastic cover indicates the left side, and R2 indicates the right side.
2. When the hook is on the front, the flat gray plastic piece on the left side of the hook is the left side, and the flat gray plastic piece on the right side of the hook is the right side.

Disassembly and assembly diagram of white plastic cover:

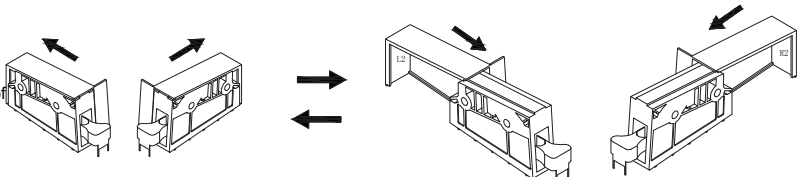



Slide the white plastic cover backwards to detach it.

To install, slide the white plastic cover forward along the slot from the back.

INSTALLATION STEPS

STEP 15

	N x 2PCS
	O x 3PCS

Split N into two parts and mount on 3. Pass the light strip through N, and mount the other part of N. The cable for the light strip is located in the open position of N.

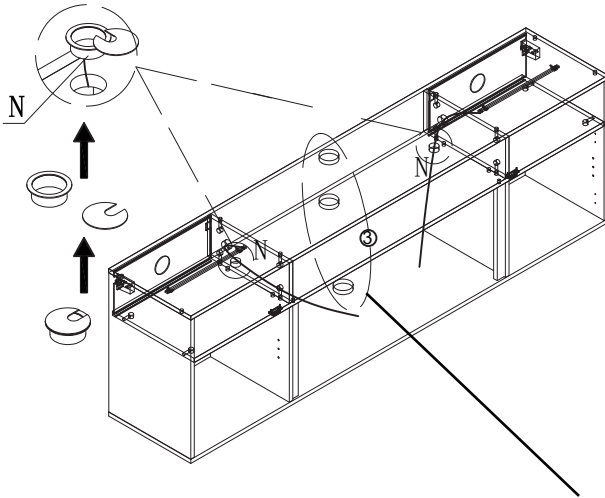

Method of the power cord through PartO:

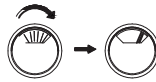

Press the part with a stripe part, rotate clockwise.

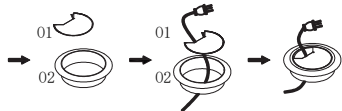



Then disassemble two parts.

Pass the power cord through O1 and O2, the line should be kept in the middle of the O1 gap, and then the O1 is built into O2.

INSTALLATION STEPS

STEP 16

	I1 x 2PCS
	J x 8PCS

Drill 8 holes in the wall in the desired locations. Then tap the plastic piece of J into the holes. Fasten I1 to the wall with the screws of J. Finally, connect I2 on the cabinet to I1.

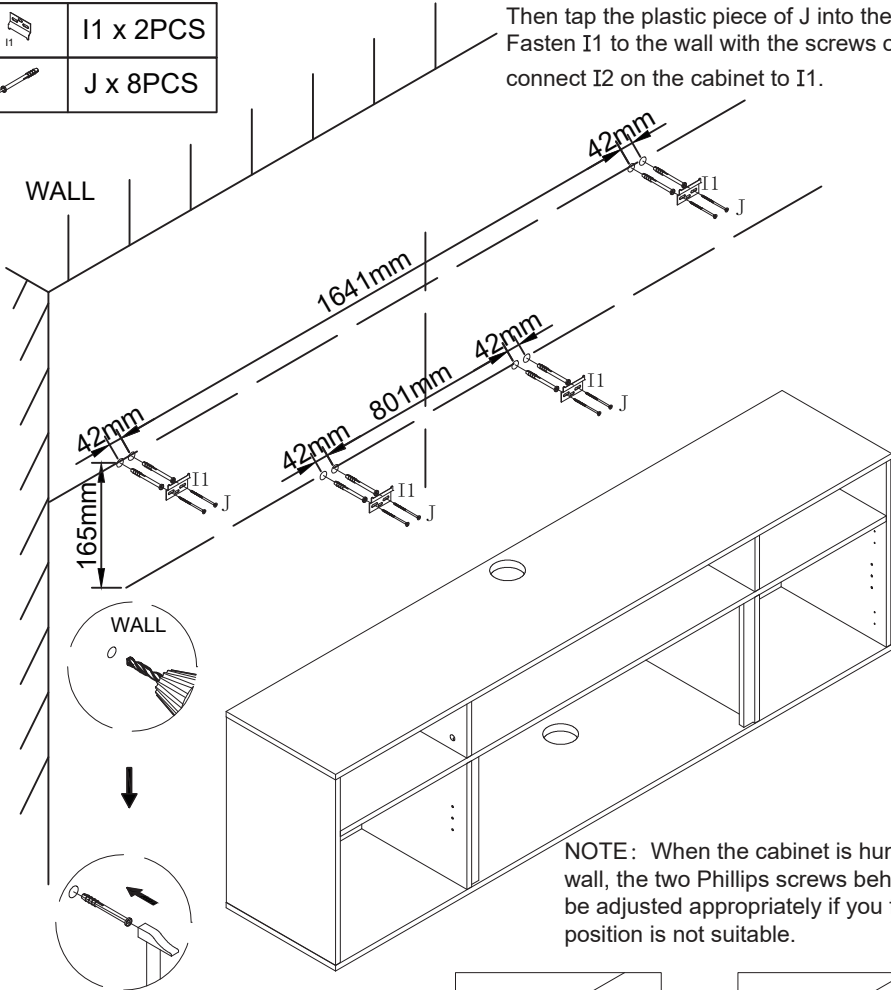

NOTE: When the cabinet is hung on the wall, the two Phillips screws behind I2 can be adjusted appropriately if you find that the position is not suitable.

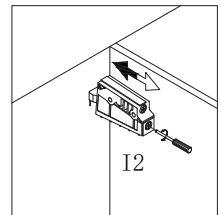
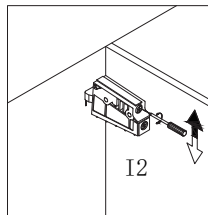

INSTALLATION STEPS

STEP 17



Ex 8PCS

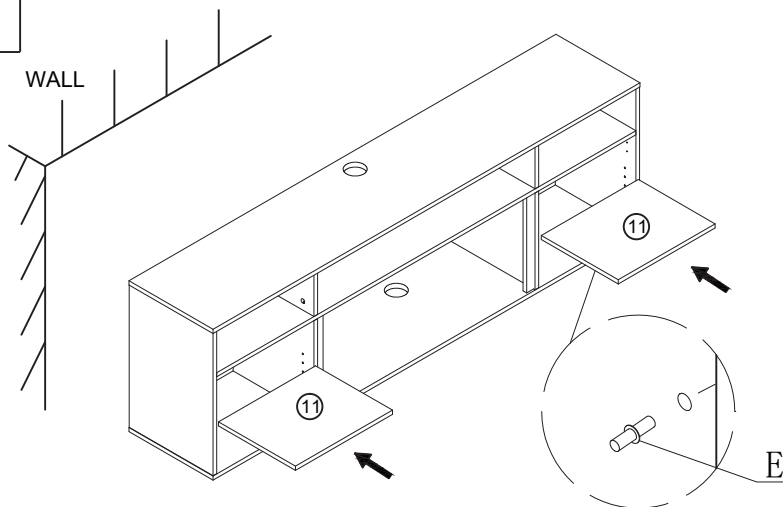

STEP 18



D x 2PCS



H2 x 2PCS



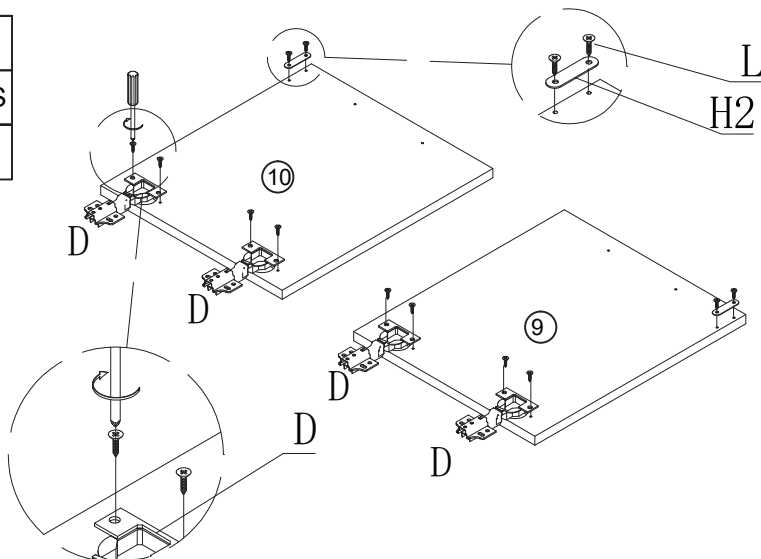

L x 4PCS



INSTALLATION STEPS

STEP 19

	D x 2PCS
	G x 2PCS
	F x 12PCS

When mounting the 10 to the 5, first install the 4 screws in the oval holes of the D (corresponding to the 4 small holes of the 5). Close the 10 and see if the position fits. If it doesn't fit, you can adjust the position up and down, left and right by using the D screws, and tighten the screws after adjusting it. Install 9 to 4 in the same way.

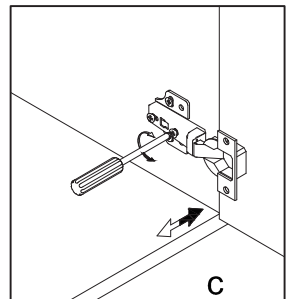
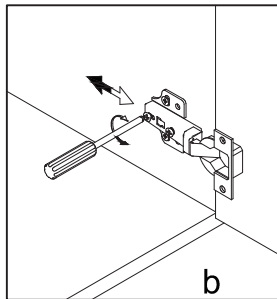
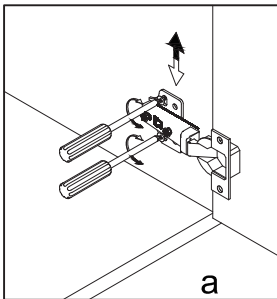
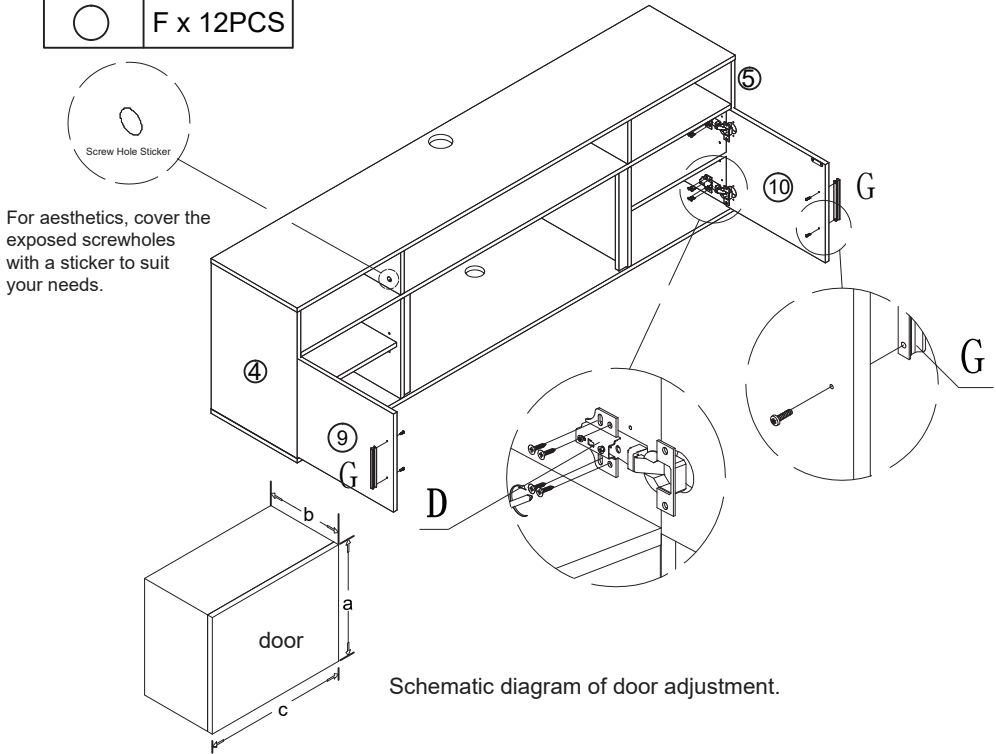

INSTALLATION STEPS

STEP 20

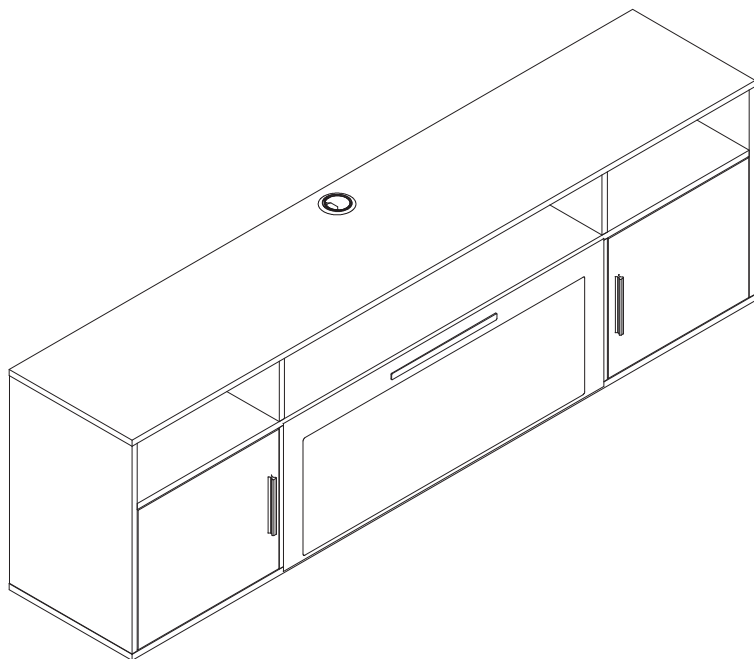

Installation details of fireplace please check the manual of fireplace.

HELP CENTER

WE STAND BEHIND THE QUALITY OF OUR PRODUCT

1. If you have any other issues with your item(s), please feel free to contact us! We will always do our best to come up with a solution that you will be happy with.
2. Please get in touch with our customer service team before returning the item(s).
3. Please do not throw away the original box(es) if you have not finished assembling and confirmed no quality issues.

RETURN POLICY

Length of return period:

You can return the item(s) within 30 days of purchase.

In the meanwhile, everything you purchased from us comes with a one-year warranty.

Who is responsible for the return shipping fee:

We will cover the return shipping fees if:

1. Your item has a manufacturing defect in materials or workmanship. For example, material cracking or screw hole misalignment. We will send you a prepaid shipping label after you send us photos or videos of the defects.
2. Your item has been damaged in transit. For example, metal part is broken or product is damaged. We will send you a prepaid shipping label after you send us photos of the damage.
3. You receive the wrong box(es) due to a warehouse error, We will send you a prepaid shipping label after you send us photos of the item(s), shipping label(s) and words(SKU) on the outer box(es).

* However, we still hope to work with you for a better solution instead of a return. Please don't hesitate to contact our customer service team.

Customer will cover the return shipping fees if:

1. You don't like the item(s) after receiving the box(es).
2. You no longer need the item(s) but have received the box(es).
3. You buy the item(s) by mistake but have received the box(es).
4. Order/shipment cancellation failed, and you have received the box(es).

Return Request

In order to get a full refund as described in this return policy, all items must be:

1. In a brand new/unused condition. Please provide photos before and after packaging.
2. All accessories and parts must be firmly packed in all original packaging before returning. If your return does not meet these requirements, you may not receive a full refund.

When can I receive a refund?

After you return it using the prepaid shipping label we provided and inform us, the refund will be issued once the package(s) have been returned to our warehouse.

What if the product is damaged/defective outside of the valid return period?

We want you to be a happy customer. Please reach out to us via email or text, and we will work on a solution to ensure your satisfaction.