

WARRANTY

WHAT IS COVERED

We warrant the product to be free from defects in material or workmanship for a period of one year from the date of original retail purchase. The word "defects" is defined as imperfections that impair the use of the product. Defects resulting from misuse, abuse or customer negligence will void this warranty.

WHAT IS NOT COVERED

This warranty does not cover commercial use, hardware, acts of nature, fire, freezing and abusive use. This warranty does not cover defects due to alteration or accidents. This warranty does not cover scratches, scuffs or other cosmetic damages that may result from normal use of the product.

CARE INSTRUCTIONS

Thank you for choosing SHOE BENCH. With a little care and maintainance, the northbeam SHOE BENCH will provide you with comfort and enjoyment for many years to come!

- To clean panels, use clean water on a damp cloth.
- When assembling SHOE BENCH, please handle all the panels and/or hardware with care to avoid any possibilities of damages and/or injuries.

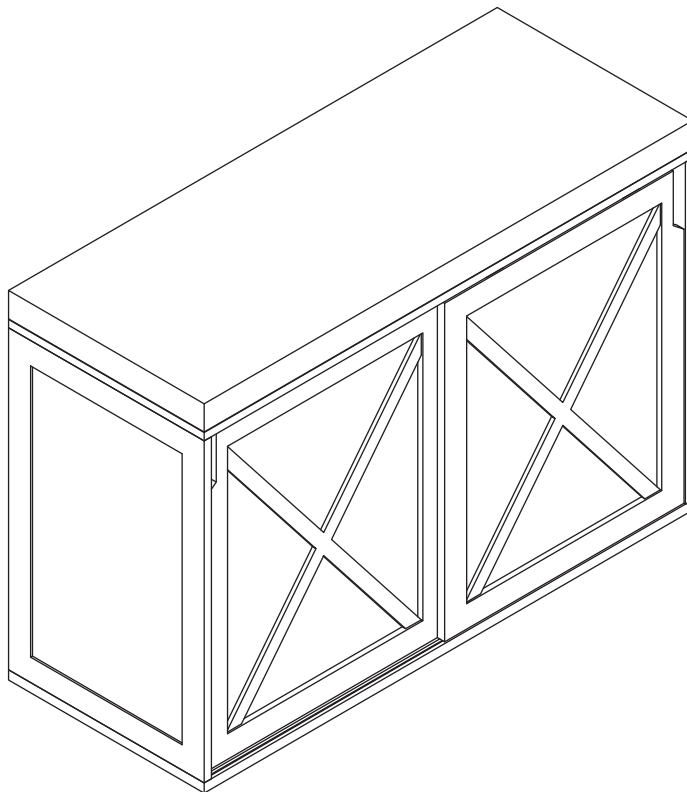

NOTE: Please read all instructions carefully before starting assembly. Also, we recommend that the unit is fully assembled on a level surface. Two people are recommended to assemble this product. **DO NOT** over torque screws and bolts.

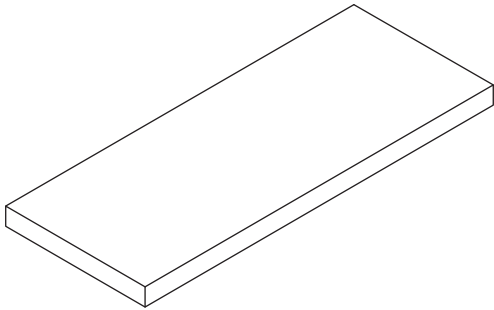
**A**

CUSHION

X 1PC

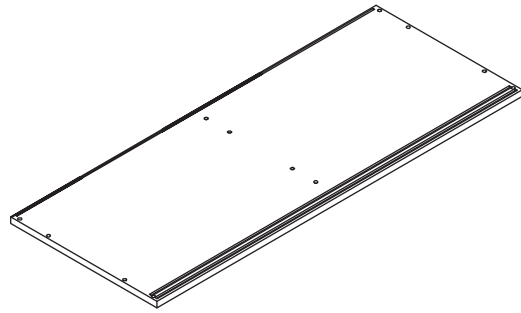
**B**

INTERIOR TOP PANEL

X 1PC

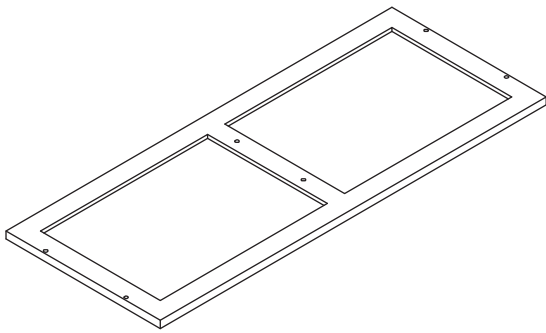
**C**

BOTTOM PANEL

X 1PC

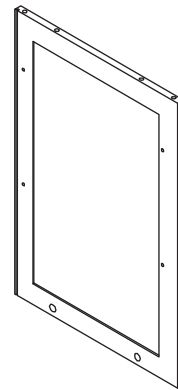
**D**

LEFT SIDE PANEL

X 1PC

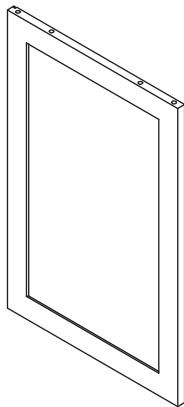
**E**

RIGHT SIDE PANEL

X 1PC

**F**

MIDDLE INTERIOR PANEL

X 1PC

NOTE: Please read all instructions carefully before starting assembly.
 Also, we recommend that the unit is fully assembled on a level surface.
 Two people are recommended to assemble this product.
 DO NOT over torque screws and bolts.

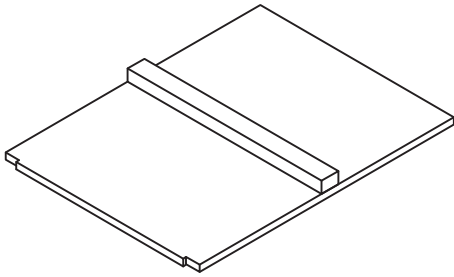
**G** SHELF

X 4PCS

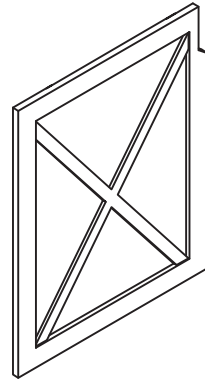
**H** RIGHT DOOR

X 1PC

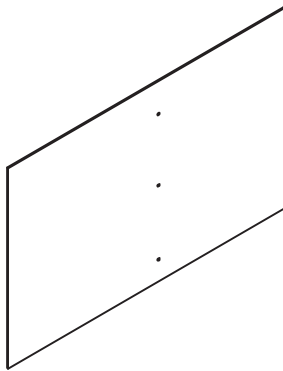
**I** BACK PANEL

X 1PC

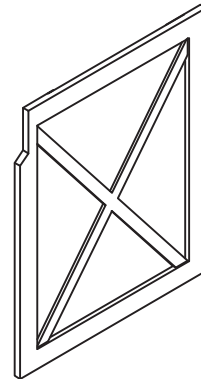
**J** LEFT DOOR

X 1PC



NOTE: Please read all instructions carefully before starting assembly.
 Also, we recommend that the unit is fully assembled on a level surface.
 Two people are recommended to assemble this product.
 DO NOT over torque screws and bolts.

3 _____  SMALL CAM _____ **2+1PCS**

4 _____  HOLE CAP _____ **6+1PCS**

5 _____  SCREW _____ **6+1PCS**

6 _____  SHELF BRACKET _____ **16+2PCS**

7 _____  PAN HEAD SCREW _____ **3+1PCS**

8 _____  LARGE CAM _____ **4+1PCS**

NOTE: Please read all instructions carefully before starting assembly.
Also, we recommend that the unit is fully assembled on a level surface.
Two people are recommended to assemble this product.
DO NOT over torque screws and bolts.

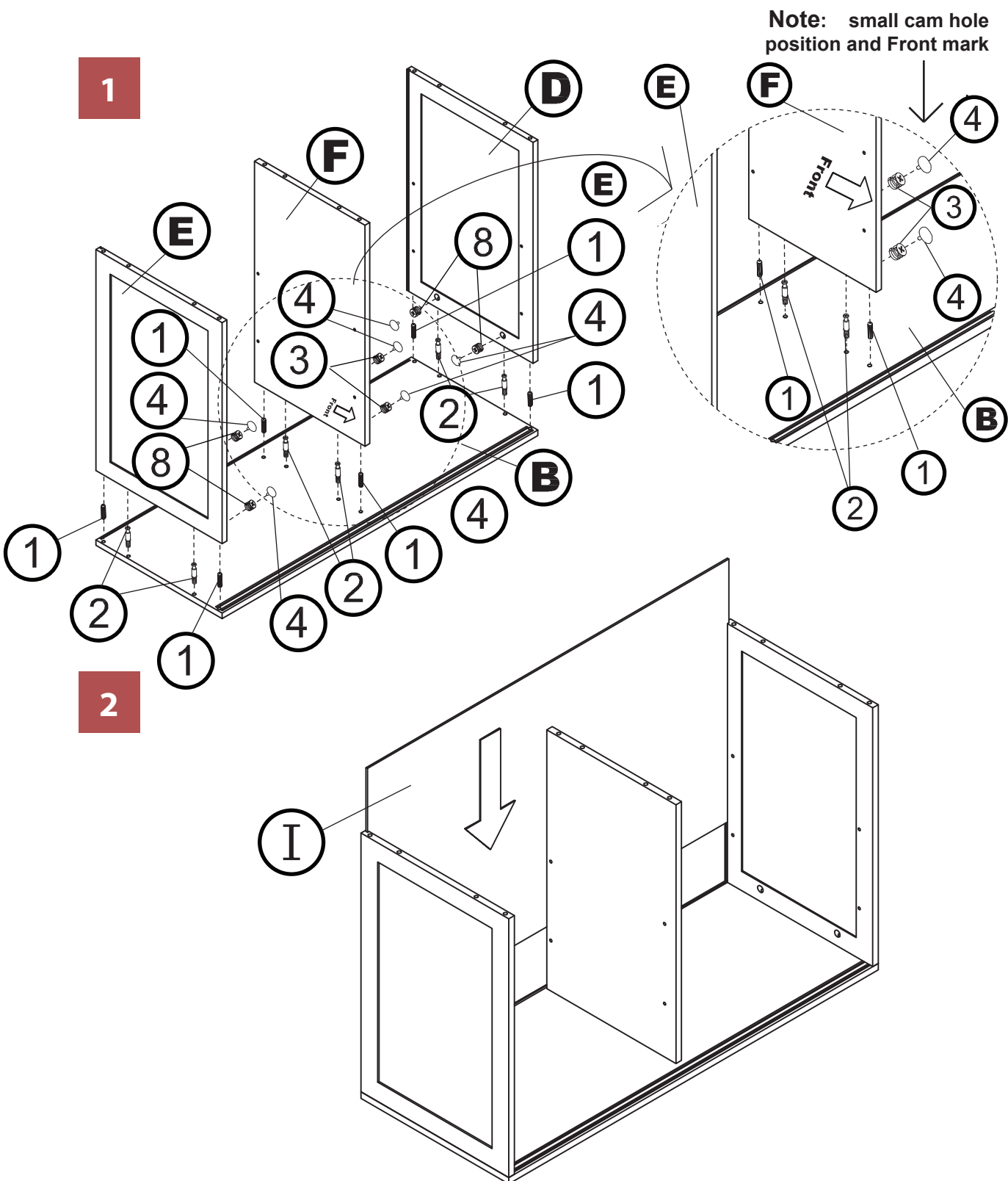

NOTE: Please read all instructions carefully before starting assembly. Also, we recommend that the unit is fully assembled on a level surface. Two people are recommended to assemble this product. DO NOT over torque screws and bolts.

3

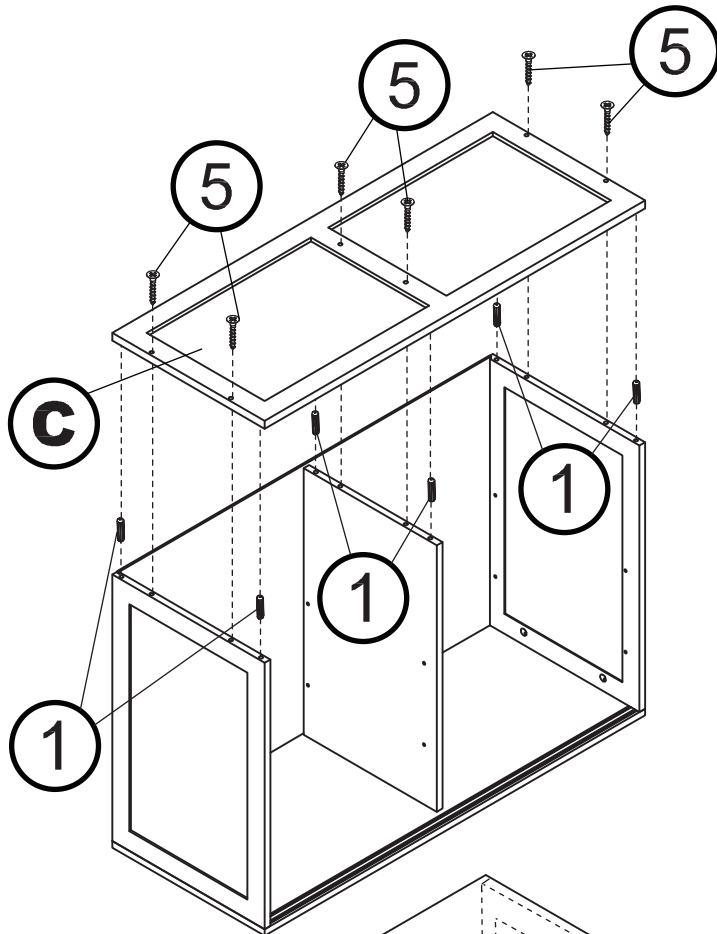

4

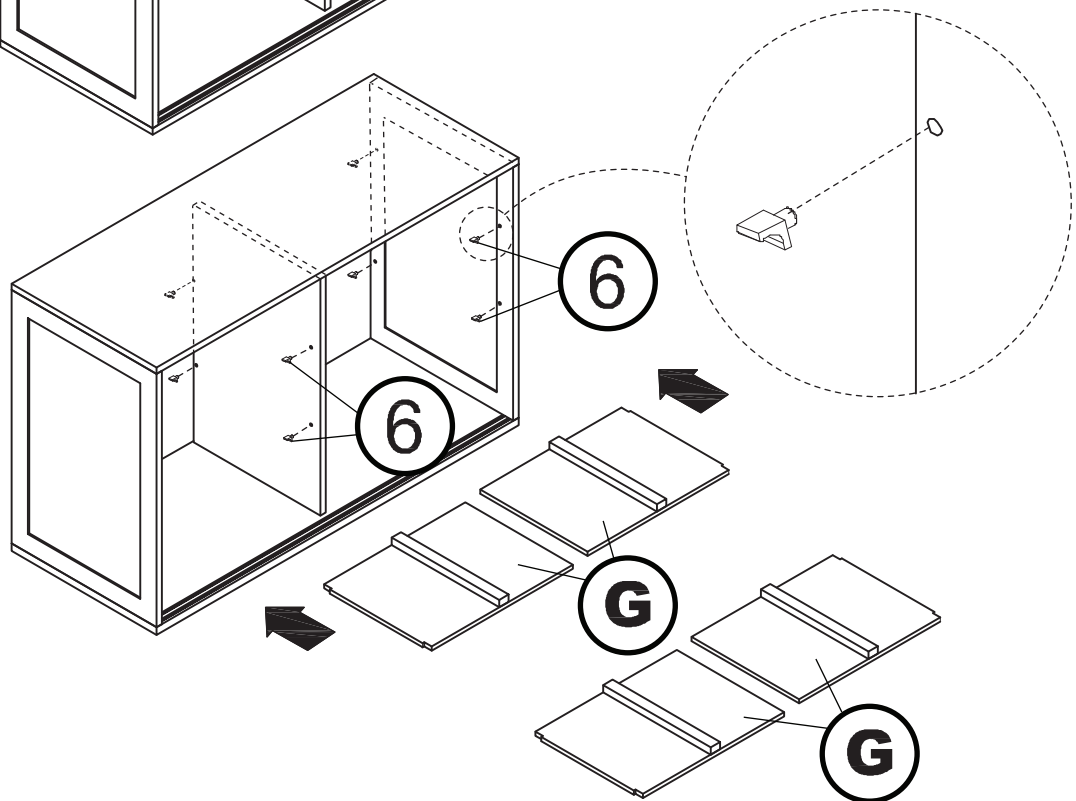

NOTE: Please read all instructions carefully before starting assembly. Also, we recommend that the unit is fully assembled on a level surface. Two people are recommended to assemble this product. DO NOT over torque screws and bolts.

5

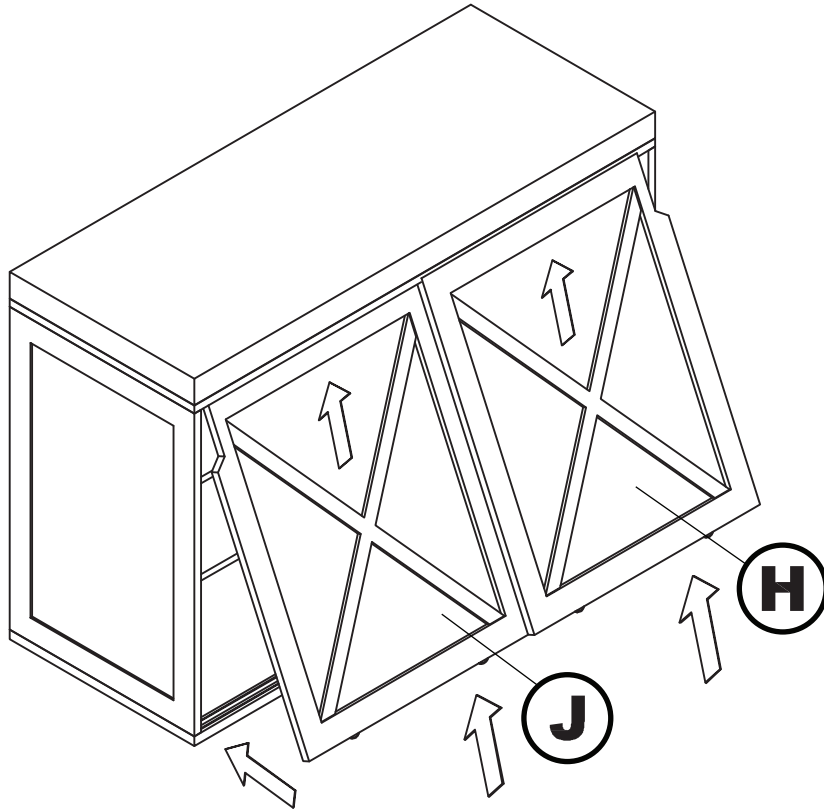

6

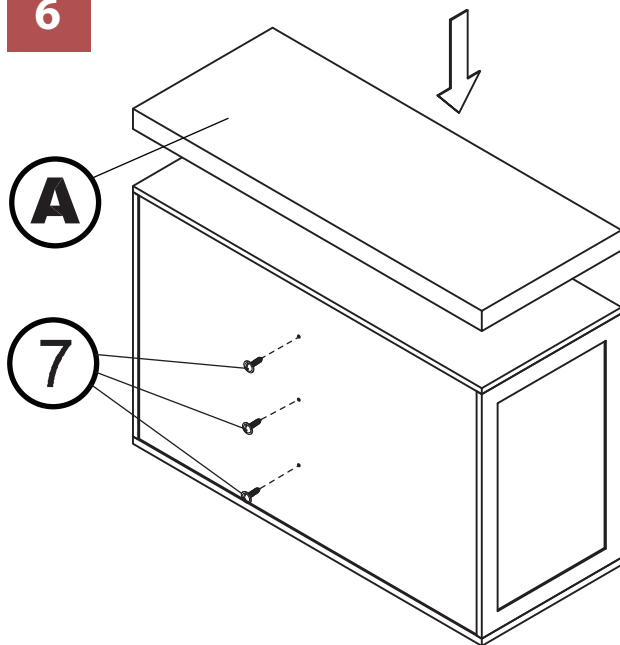

OK!

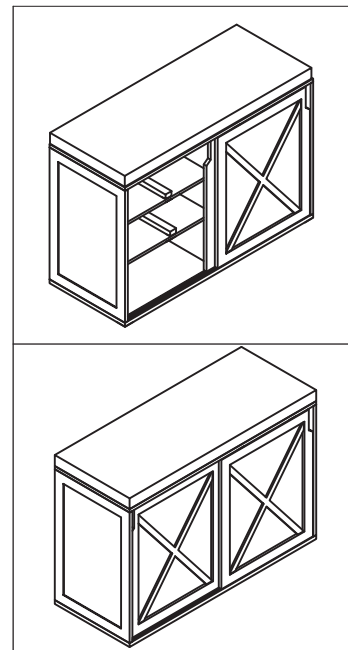

NOTE: Please read all instructions carefully before starting assembly. Also, we recommend that the unit is fully assembled on a level surface. Two people are recommended to assemble this product. DO NOT over torque screws and bolts.