

---

# Instruction

---

**IMPORTANT! KEEP INSTRUCTION  
MANUAL FOR FUTURE USE.**

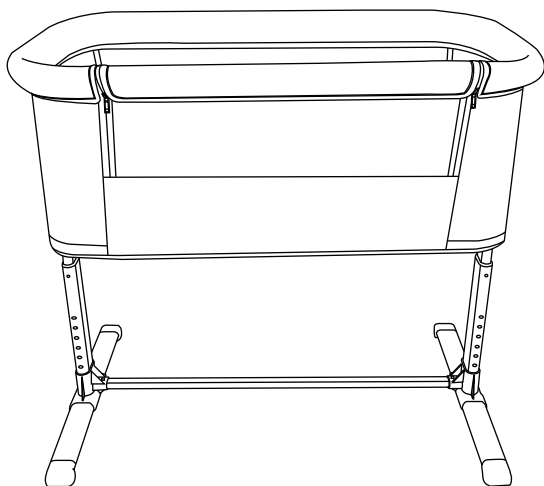

**NATURE INTERNATIONAL  
TRADING INC.  
597 BEAVER CREEK CT,  
BRIGHTON, CO 80601  
Email ADD: [tfsservices@163.com](mailto:tfsservices@163.com)**

**USER'S MANUAL**  

---

**BABY BEDSIDE SLEEPERS  
ETD046**

**Read all instructions before assembling and using the product.**

DO NOT use bedside sleeper if any parts are missing, damaged, or broken. Contact INTERIOR FIRM LTD for replacement parts and instructional literature if needed. DO NOT substitute parts.

## INSTRUCTIONS FOR USE AND MAINTENANCE

- Oil rotating parts regularly to improve the life of the product.
- Wipe clean with a soft, dry cloth, sponge or brush.
- Do not use acidic or alkaline water to clean metal components.
- Store the crib in a dry, safe place, when not in use.

### Parts included

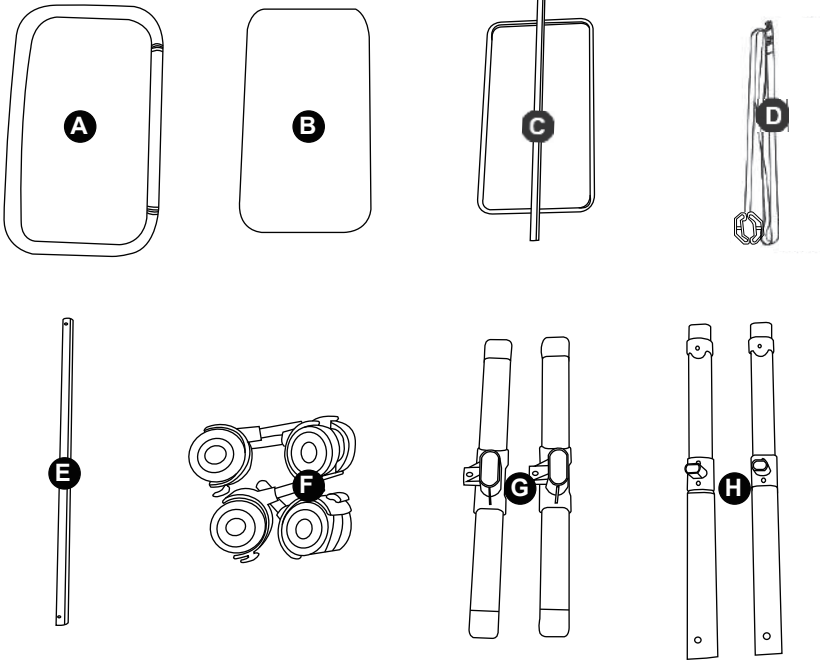

A、 Baby bed frame x1

B、 Mattress x1

C、 Fixing bars x1

D、 Straps for fixing to parent bed x1

E、 Tube x1

F、 Wheels x4

G、 Base x2

H、 Adjustable support rod x2

# Assembly instructions

step1

Insert the adjustable support rod (part H) into the sides of the baby bed frame (part A)



step2

Connect the adjustable support rod (part H) on both sides with fixing bars (part C)



step3

Connect the 2 bases (Part G) with tube (part E) to complete the base



step4

Install the entire base to the adjusting support rod (Part H)



---

## STEP 5

Paste the bed bottom fixing tape properly

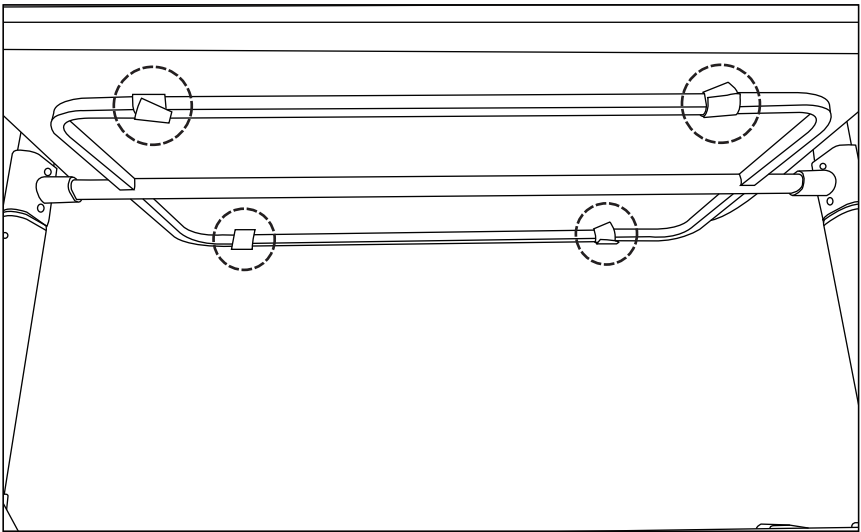

## STEP 6

Simply insert the wheel into the corresponding hole on the base.

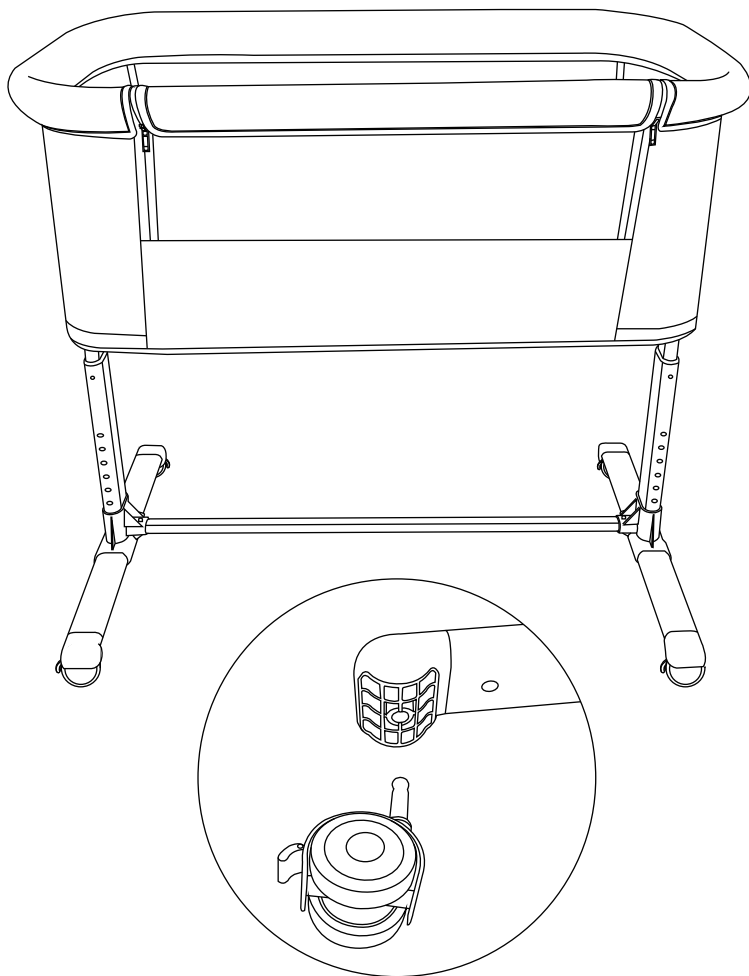

## STEP 7

Put the mattress in

W11820045-1122000000000000

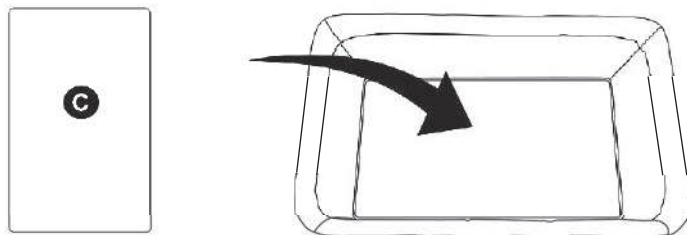

## STEP 8

Press buttons on both sides to adjust the height. There are 6 levels in total.

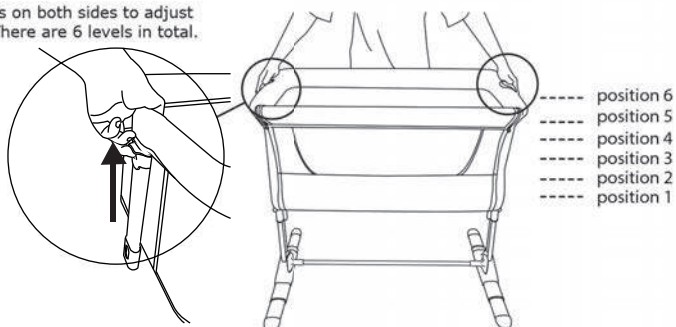

### WARNING:

Please do not put down the rail when use it as a crib.  
The adjustment gear on both sides must be kept at the same height

- 1 Put down the rail
- 2 Pass the upper tube through the fabric covep of side handrail

1

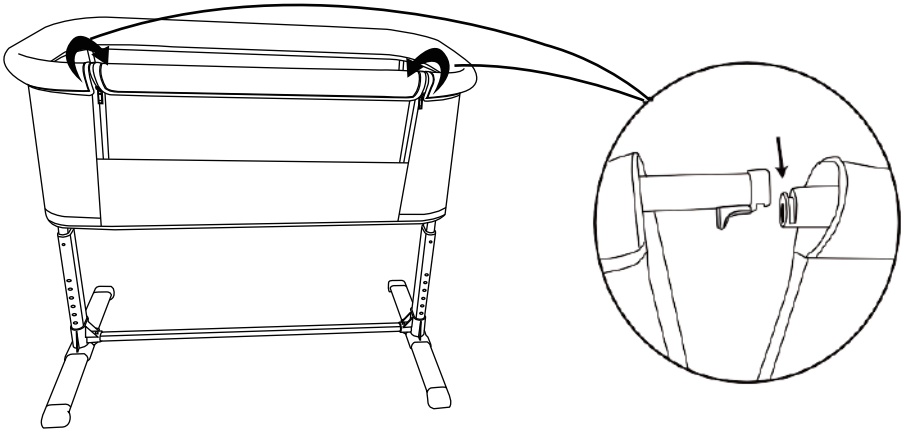

2

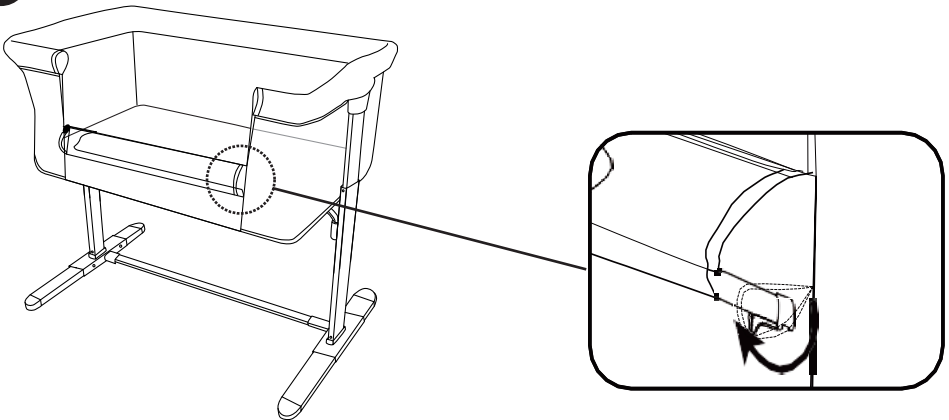

## STEP 9

Install two straps(D) on the fixing bar(C)

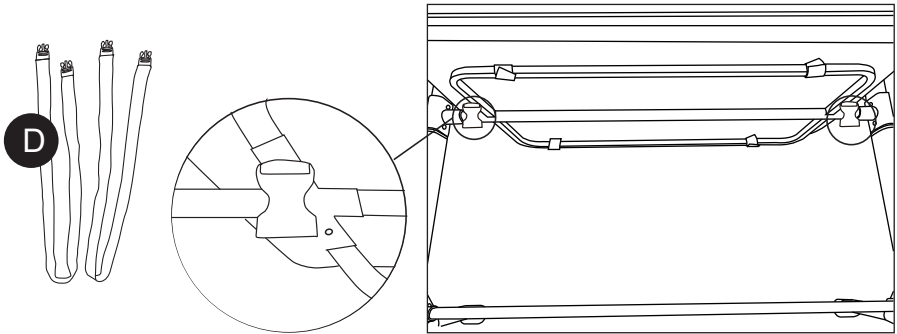

Connect the two buckles on the "co-sleeper" belt to the crib under-side as shown. A "click" will signal when secure.

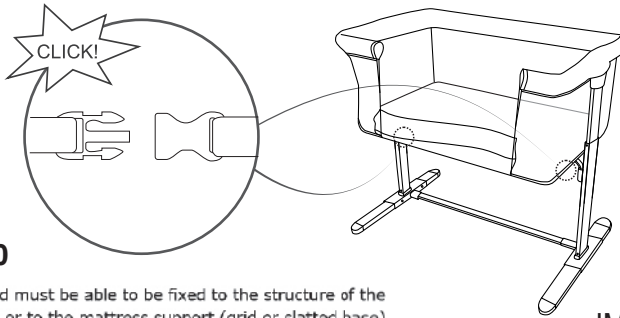

## STEP 10

The baby bed must be able to be fixed to the structure of the parents' bed or to the mattress support (grid or slatted base).

**IMPORTANT:** The fixing webbing shall parallel with the parents' bed.

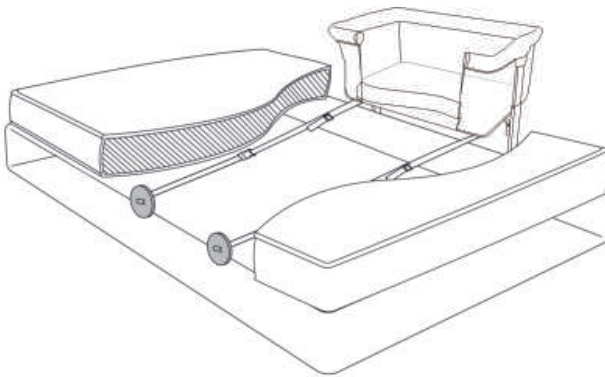

**WARNING:** The attachment system must always be used in bedside sleeper mode.

## STEP 11

### HOW TO USE STARP AND PLASTIC PLATE:

Go through the parental bed FRAME with straps, adjust the length of straps, to make the bed-side sleeper NO GAP between the BEDSIDE SLEEPER and the parental bed

Buckle the straps as shown to ensure that the straps are securely attached to the bottom rod.

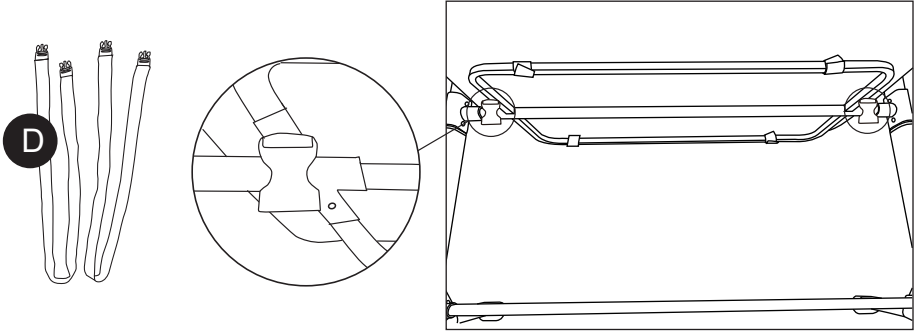

Pull on the loose ends of the belt to tighten it ensuring there is no gap between the adult bed and the crib.

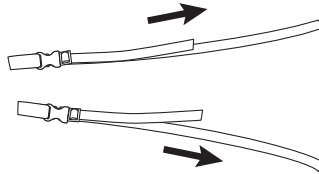

### **⚠ WARNING :**

The attachment system must always be used in bedside sleeper mode.  
Align the crib beside the adult bed. Feed the "co-sleeper belt" under-neath the adult mattress.

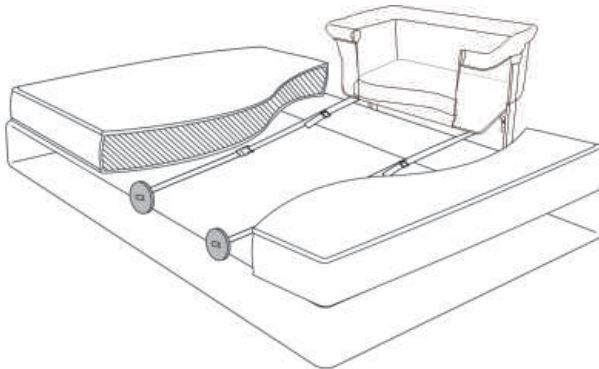

**IMPORTANT:** The fixing webbing shall parallel with the parents' bed.

## **WARNING**

1. The retractable feet must be used only in bedside sleeper mode.
  2. Dropping down the rail bar must be used only in bedside sleeper mode.
  3. The attachment system must always be used in bedside sleeper mode.
- Do not use this product without reading the instructions for use first.
  - Stop using the product as soon as the child can sit or kneel or pull itself up;
  - Placing additional items in the product may cause suffocation;
  - Do not place the product close to another product, which could present a danger of suffocation or strangulation, e.g. strings, blind/curtain cords, etc.
  - Do not use more than one mattress in the product.
  - The product should be placed on a horizontal floor.
  - Young children should not be allowed to play unsupervised in the vicinity of the crib.
  - All assembly fittings should always be tightened properly and that care should be taken that no screws are loose, because a child could trap parts of the body or clothing (e.g. Strings, necklaces, ribbons for babies' dummies, etc.), which would pose a risk of strangulation.
  - Use only the pad provided by manufacturer. NEVER add a pillow, comforter, or another mattress for padding.
  - Be aware of the risk of burning cigarettes, open fires and other sources of strong heat, such as electric bar fires, gas fires, etc. in the near vicinity of the crib.
  - Pay attention to the height of the bedside sleeper.
  - Concerning the attachment system shall be provided and the user shall not use other attachment system;
  - There shall never be a gap between the lower side of the bedside sleeper and the mattress of the adult bed.
  - If there is any gap between the bedside sleeper and the adult bed, DO NOT use product.

## **WARNING**

- “DANGER! – Always completely raise the drop side when not attached to the adult’s bed.
- Use only the pad provided by manufacturer. NEVER add a pillow, comforter or another mattress for padding.
- To avoid the risk of your child being strangled, the attachment system to the adult’s bed shall always be kept away from and out of the crib.

# **⚠ WARNING**

- The bedside sleepers shall never be used in an inclined position; To prevent a suffocation hazard from entrapment, the bedside sleeper shall be properly secured to the adult bed using the attachment system;
- Check the tightness of the attachment system before each use by pulling the bedside sleeper in a direction away from adult bed.

Mattress, Box Springs &  
Frame Aligned

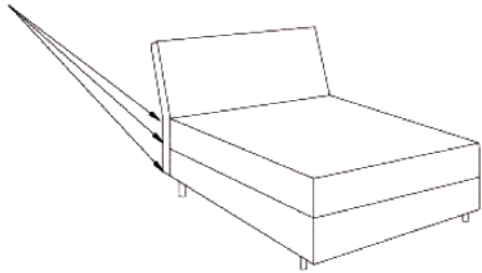

ACCEPTABLE BED  
FRAME IN-LINE

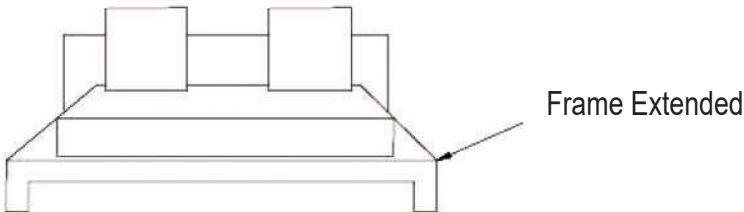

UNACCEPTABLE BED,  
MATTRESS, BOX-SPRING & FRAME NOT IN-LINE

- A bedside sleeper is designed to provide a sleeping area for an infant until he or she begins to push up on hands and knees or approximately 5 months of age. Move your child to another sleeping product when your child reaches this stage.

# ⚠ WARNING

## ⚠ WARNING

The attachment system must ALWAYS be used in bedside sleeper mode. Mattress Boxsprings & Frame aligned

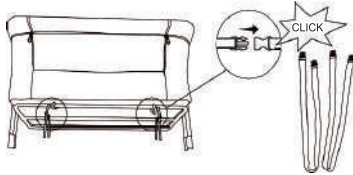
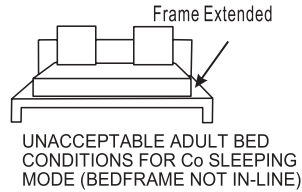

Connect the two buckles on the "co-sleeper" belt (I) to the crib underside as shown. A "click" will signal when secure.

## ⚠ WARNING

The attachment system must ALWAYS be used in bedside sleeper mode.

Not suitable for use next to water beds or children's beds.

Assemble the buckle as shown in the picture and adjust the length of the strap according to the size of the adult bed.

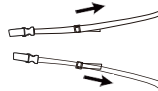
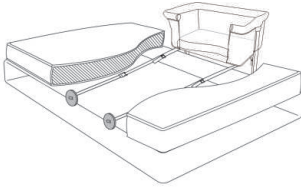

Align the crib beside the adult bed. Feed the "co-sleeper belt" underneath the adult mattress.

Pull on the loose ends of the belt to tighten it ensuring there is no gap between the adult bed and the crib.

## ⚠ WARNING

Entrapment Hazard -To prevent death from entrapment, beside sleeper must be properly secured to adult bed using the attachment system.

- (1). There must be no more than  $\frac{1}{2}$ in. (13mm) gap between beside sleeper and adult bed.
- (2). Check tightness before each use by pulling beside sleeper in a direction away from adult bed.
- (3). If gap exceeds  $\frac{1}{2}$ in. (13mm). DO NOT use product. Do not fill the gap with pillows, blankets or other items that are suffocation hazards.



**WARNING** Always read and follow assembly instructions for each product use mode (bedside sleeper, bassinet).



**WARNING** Always use ALL required parts for each use mode. Check instruction manual for a list of required parts. Periodically check product for loose, damaged, or missing parts.

Contact (NATURE INTERNATIONAL TRADING INC. Email: [tfsservices@163.com](mailto:tfsservices@163.com)) for replacement parts and instructional literature if needed. DO NOT substitute parts."

# **⚠️WARNING**

**⚠️WARNING** Failure to follow these warnings and the instructions could result in death or serious injury.

## **SUFFOCATION HAZARD**

### **Babies have suffocated:**

- on pillows, comforters, and extra padding
- in gaps between a wrong-size mattress, or extra padding and productsides

• **NEVER** add soft bedding or padding.

• **Use ONLY** mattress provided by manufacturer.

- Always place baby on back to sleep to reduce the risk of SIDS and suffocation.

### **FALL HAZARD**—To help prevent falls,

- Do not use this product when the infant begins to push up on hands and knees or has reached 30 lbs (13.6KG), whichever comes first.

• Always check that the bassinet is securely locked on the base/stand by pulling upwards on the bassinet bed.

• Strings can cause strangulation! Do not place items with a string around a child's neck, such as hood strings or pacifier cords. Do not suspend strings over a product or attach strings to toys.

- Do not use if any part of the bedside sleeper is broken, torn, or missing.

**⚠️WARNING** This bedside sleeper is designed for use only with adult beds that are between 22.4 and 26.8 inches (570 mm to 680 mm) from floor to top of adult mattress.

**⚠️WARNING** To avoid death from the infant's neck being caught on the top rail on the side that is next to the adult bed, the lowered portion of the top rail must be no higher than the adult bed mattress.

**⚠️WARNING** A bedside sleeper is designed to provide a sleeping area for an infant until he or she begins to push up on hands and knees or approximately 5 months of age.

- The attachment is assembled according to the manufacturer's instructions to any mode of bedside sleeper or bassinet or play yard.

## CARE AND CLEANING

Mattress Remove from mattress foam, Soft Machine wash or hand wash with cold water, gentle cycle.

No bleach, Tumble dry, Low heat.

Toy bar and toys: Wipe clean with a damp cloth and mild soap. Air dry. Don't immerse in water.

Frame: Wipe the metal frame with soft, clean cloth and mild soap.



**Email ADD: [tfservices@163.com](mailto:tfservices@163.com)**