

Bookcase

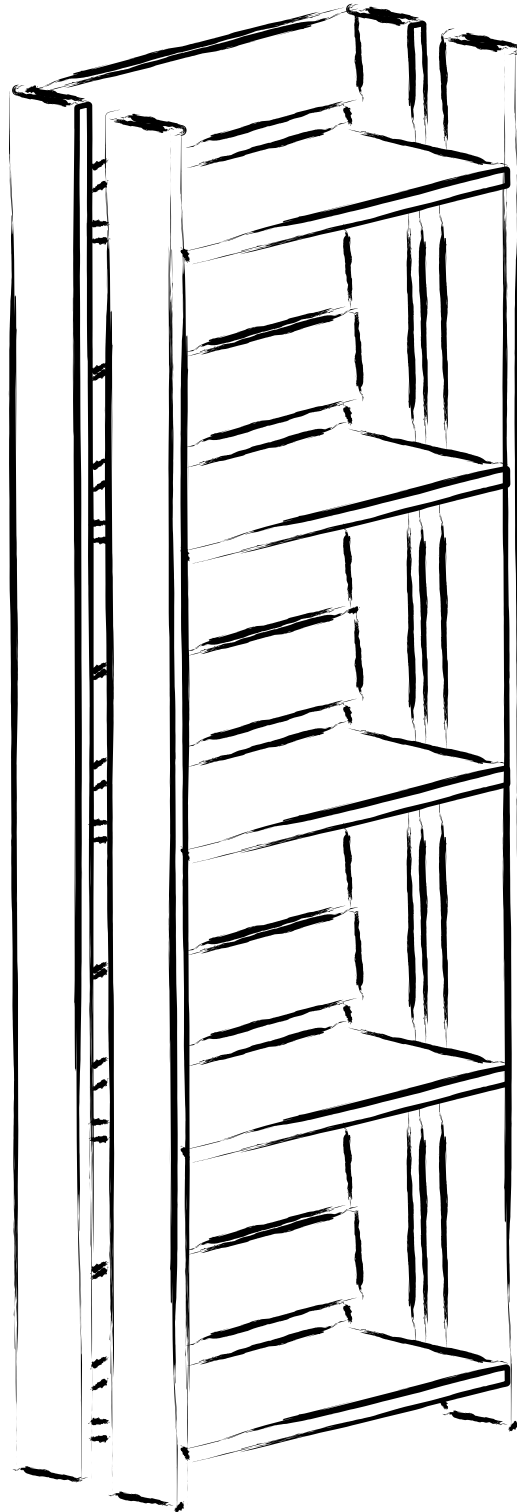

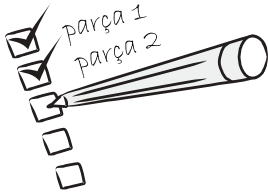

We design and produce our product for people to love and have fun with them as we do.
The product you bought was subjected to all sorts of tests and control before sending out to you.



Before start assembling, please check the whole components and accessories according to the lists. If you bought more than one product, to prevent confusion be sure that you completed the first product. Then start the other product's assembling.



Before start assembling, please clean all the components with a damp cloth. Also for usual cleaning, this will be enough.



Although all the products are produced and packed carefully, sometimes happen that some component is damaged during the transportation. In such a case please check the missing or damaged part and do not hesitate to contact us.

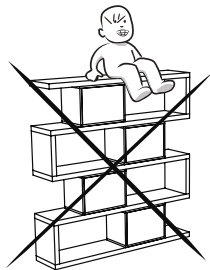

Do not use furniture for other purposes. If you would like to use it, please contact us for further questions.

Do not directly contact your furniture with excessive heat, cold and humidity because the product can be affected.



WARNING

Serious or fatal crushing injuries can occur from furniture tip-over. To prevent this furniture from tipping over it must be permanently fixed to the wall with the included wall attachment devices.

Fixing devices for the wall are not included since different wall materials require different types of fixing devices. Use fixing devices suitable for the walls in your home. For advice on suitable fixing systems, contact your local specialized dealer.

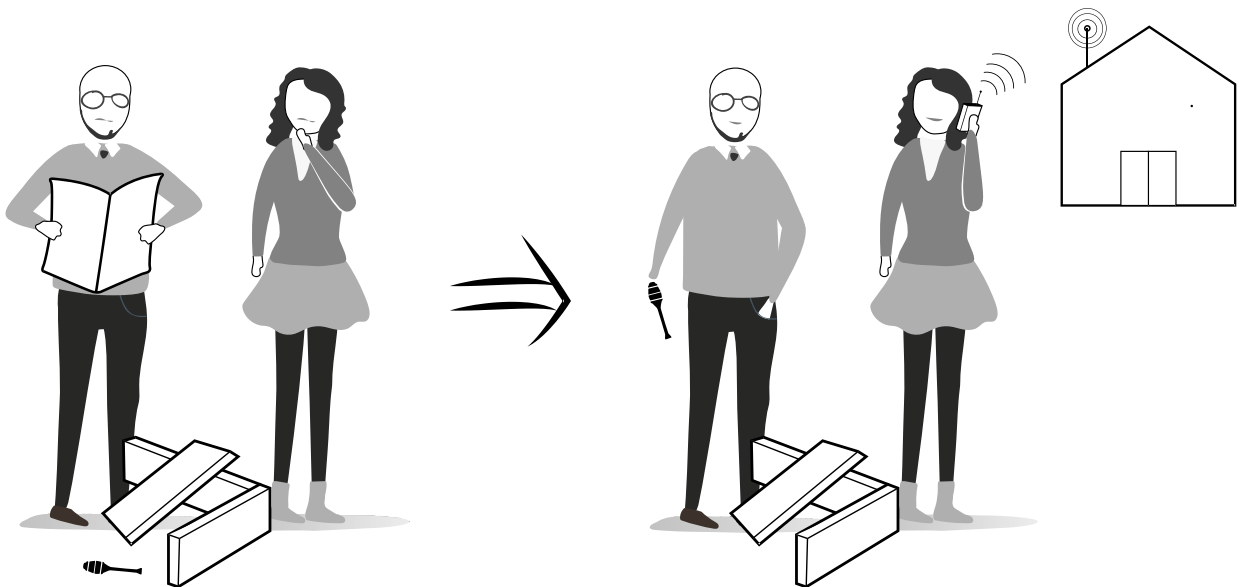
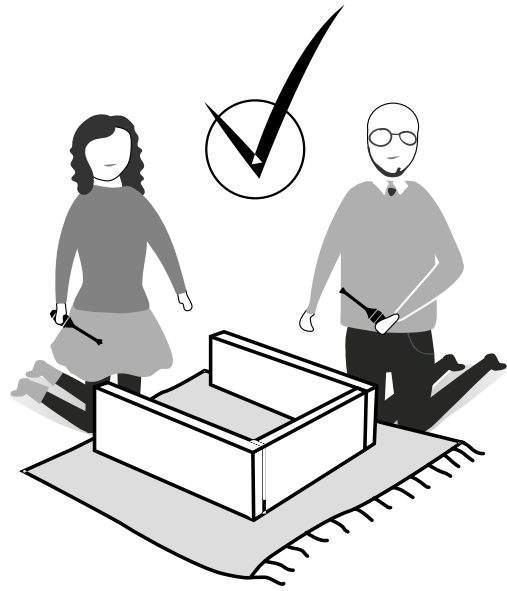
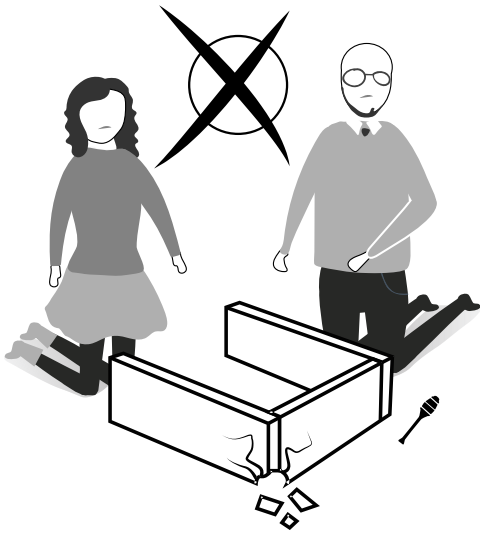
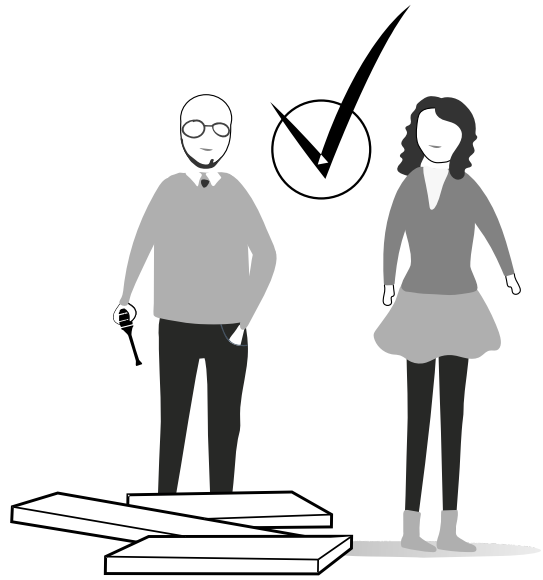
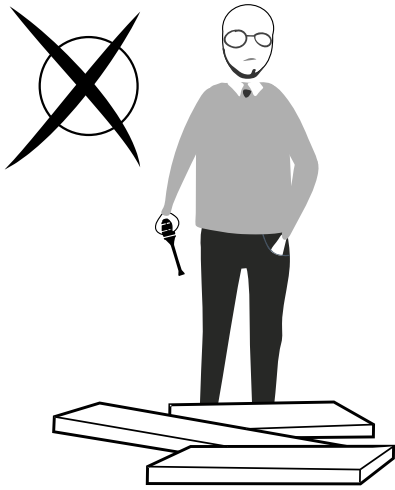

ATTENTION !!

Minifix is the main connection material used in ada products.
Before starting assembly, please check the drawings below.

A04

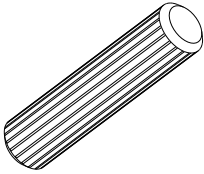

A23

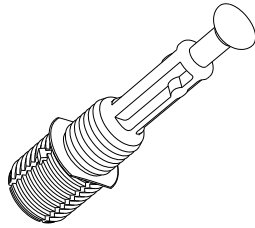

A22

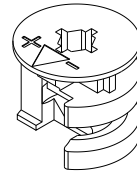

1. step

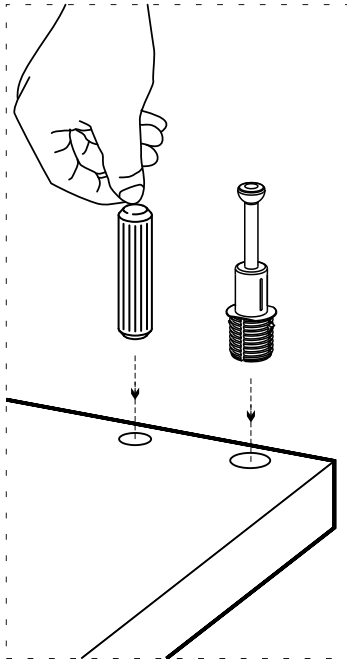

2. step

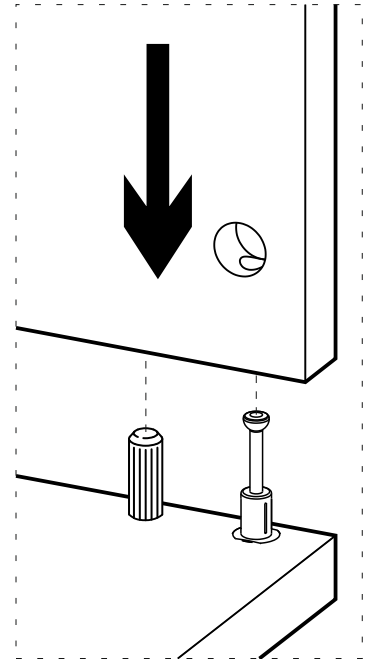

3. step

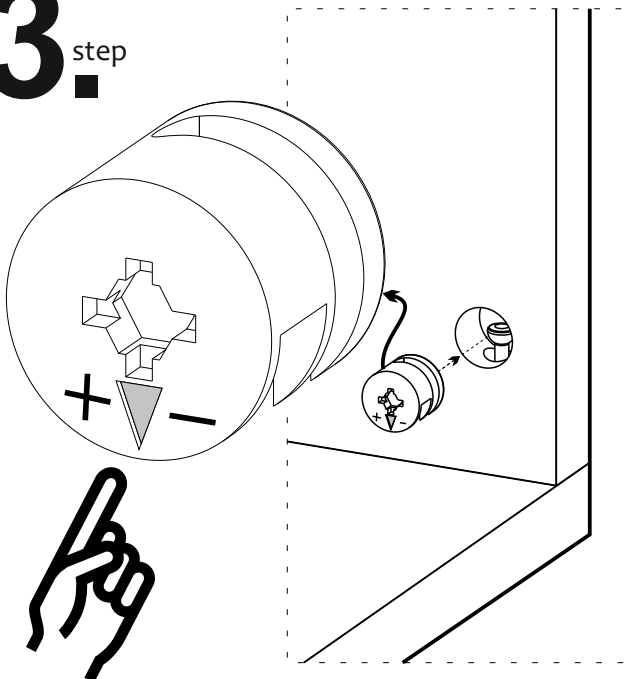



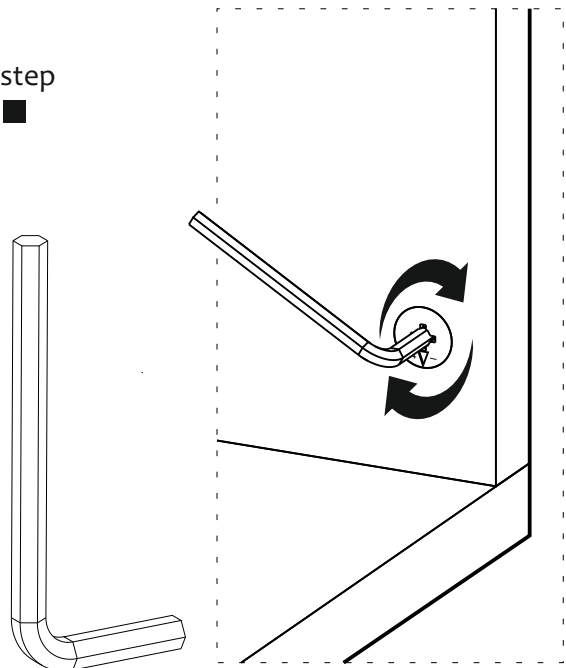

4. step



Follow the installation steps in the order as shown.
Position the parts as shown in the installation guide steps.

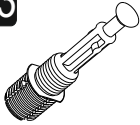
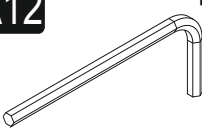

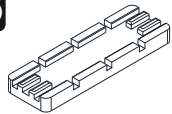
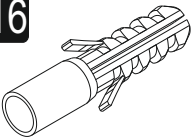
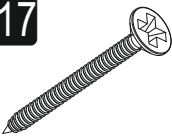
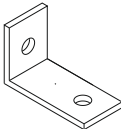
ACCESSORY LIST

A22  Minifix k18 60x	A23  Minifix M10 60x	A12  4 SW 2x	A06  18 mm C1 40x C2 20x	A08  4x
A16  Ø8 2x	A17  4x50 2x	A35  -L- 2x	A18  3,5x18 2x	

GENERAL VIEW

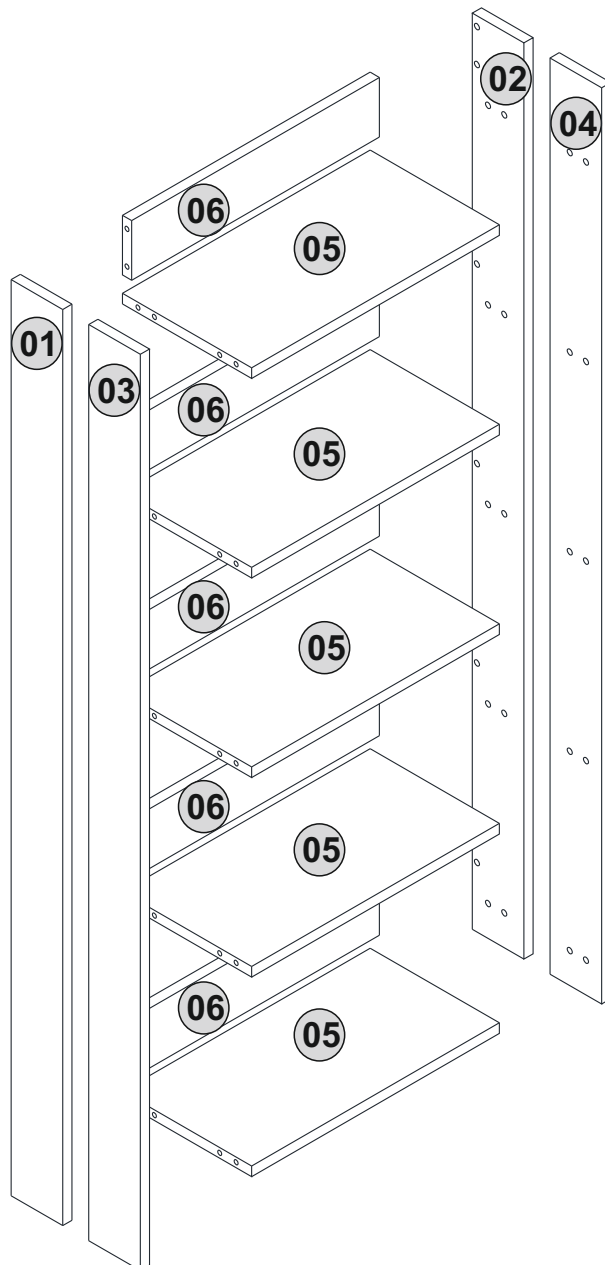

1. step

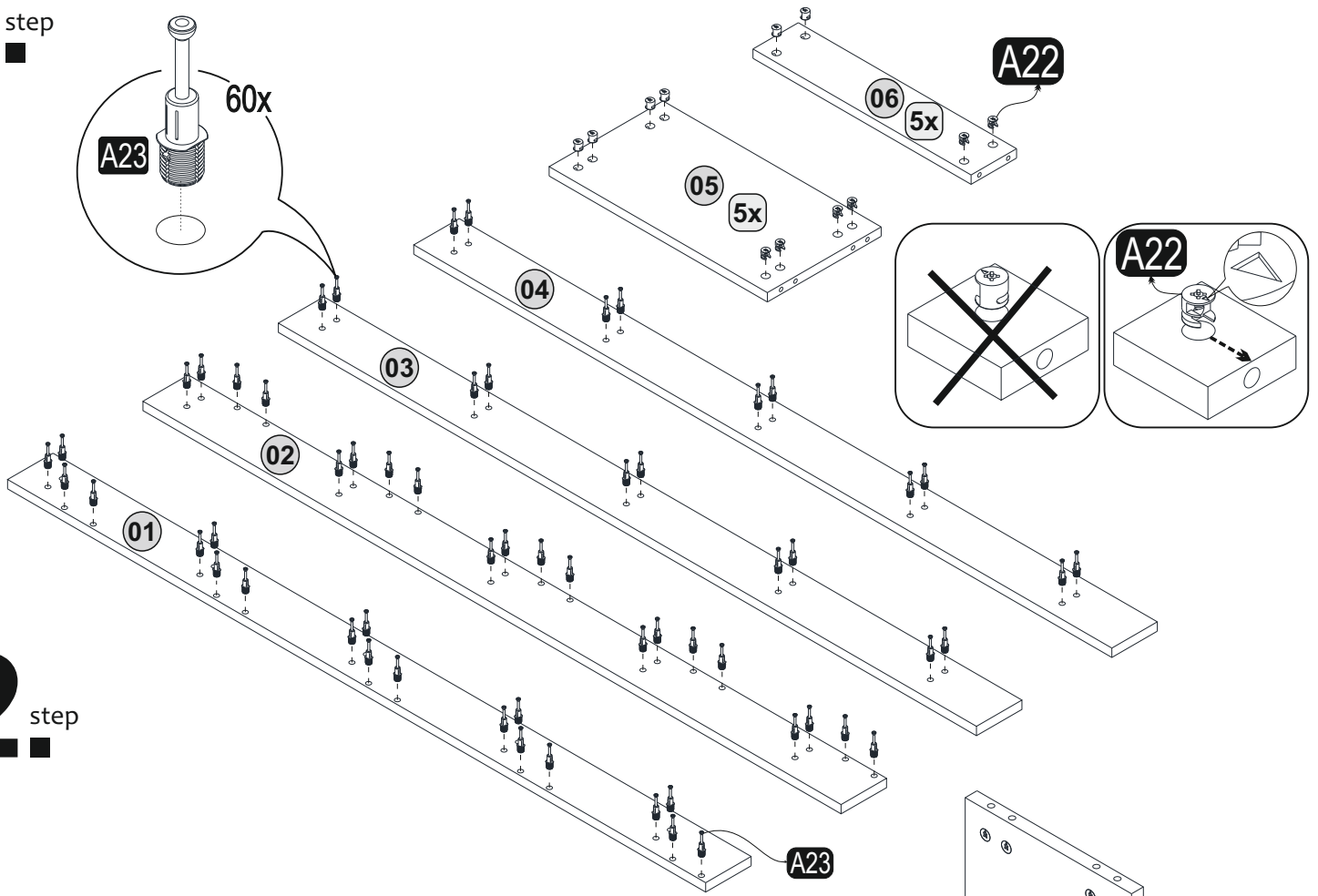

2. step

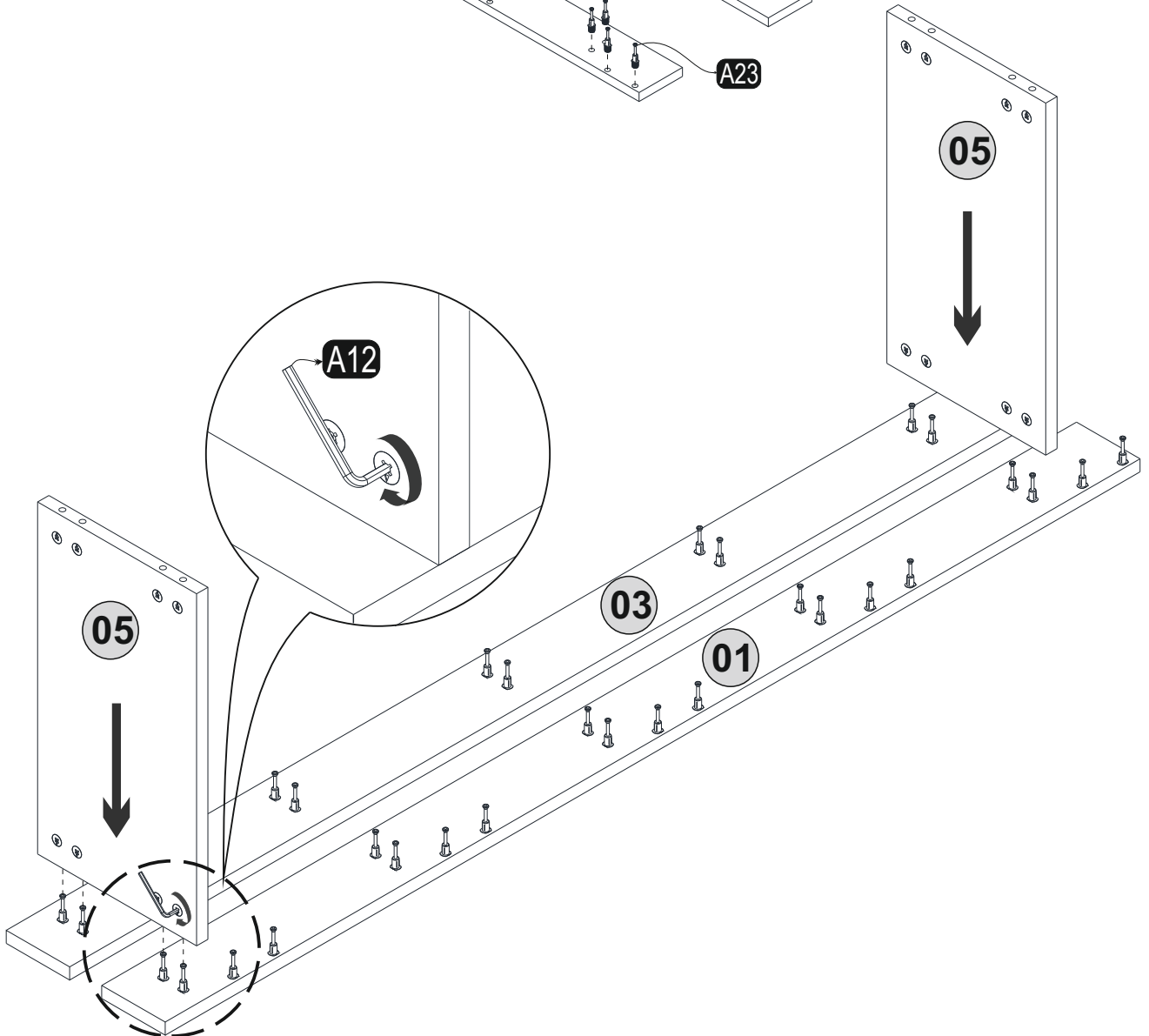

3_{step}

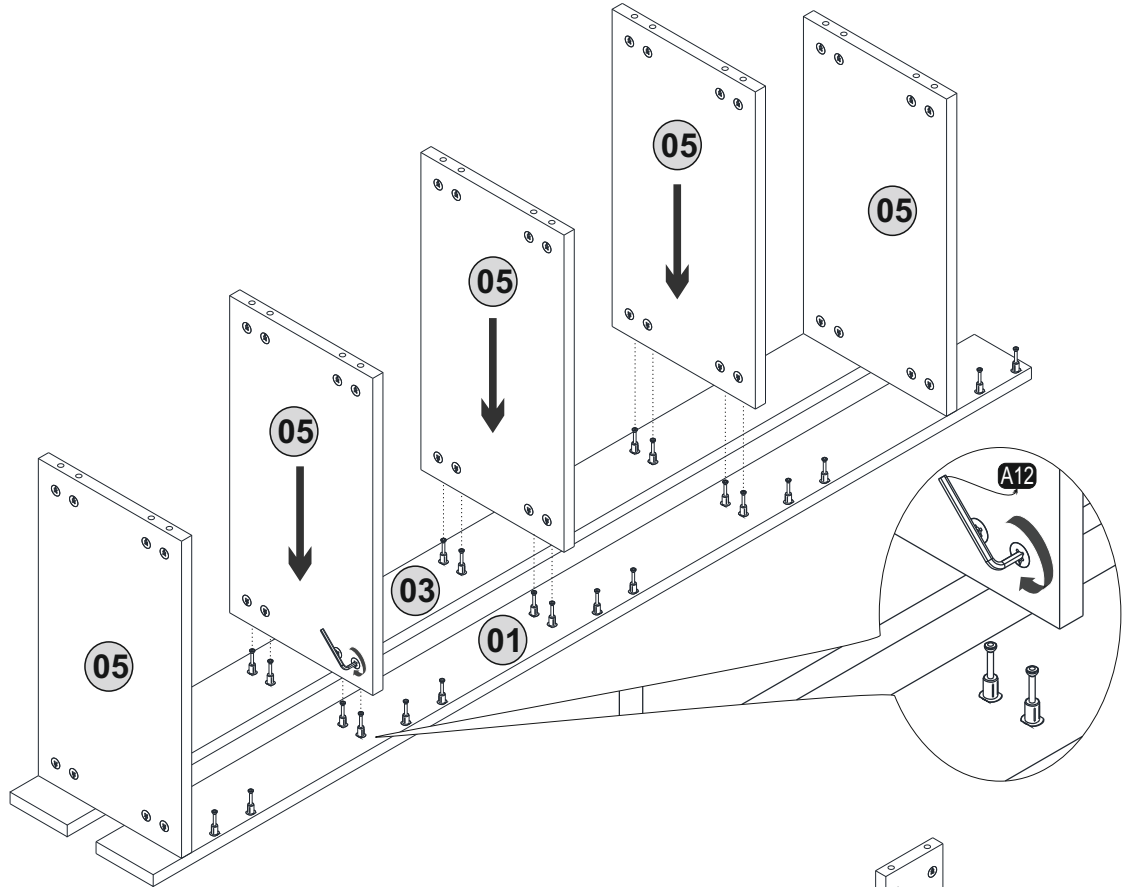

4_{step}

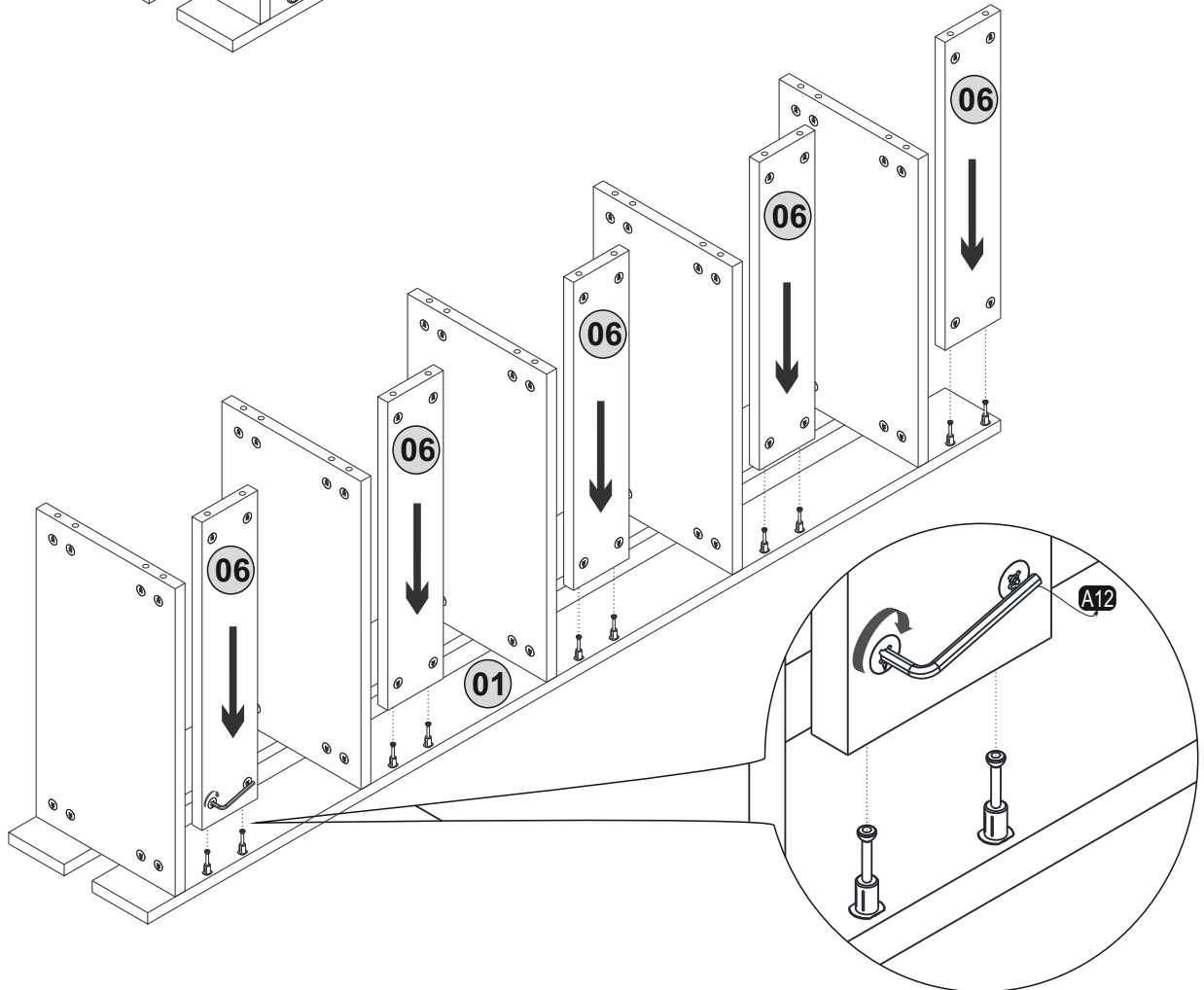

5 step

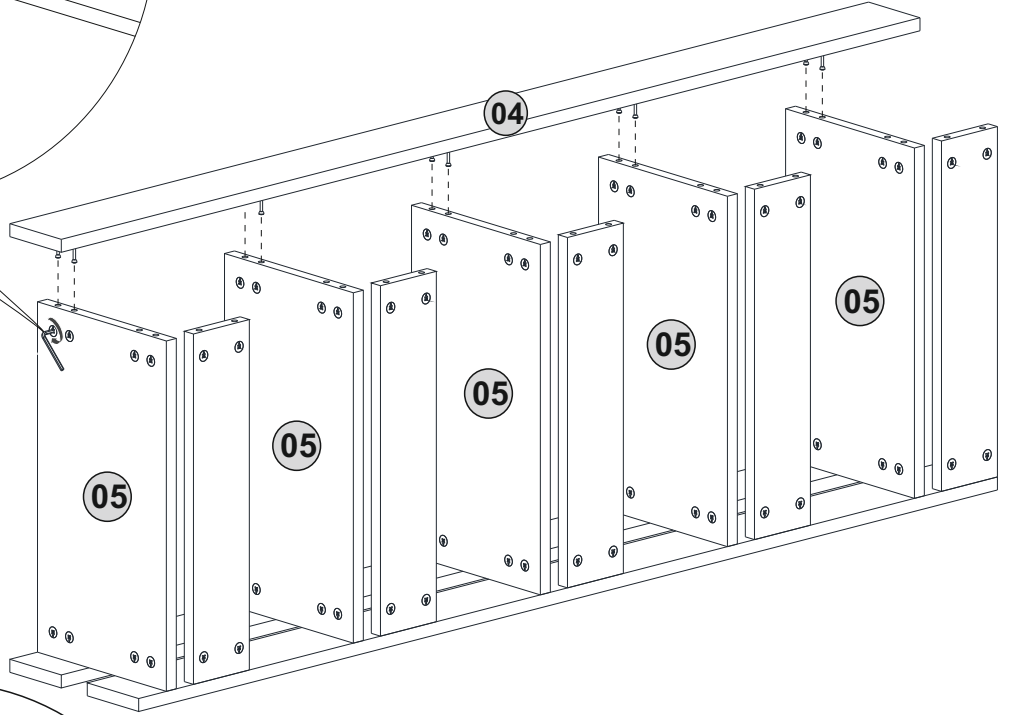
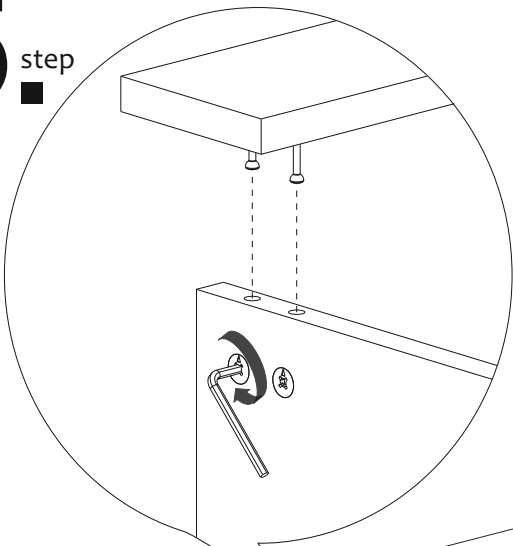

6 step

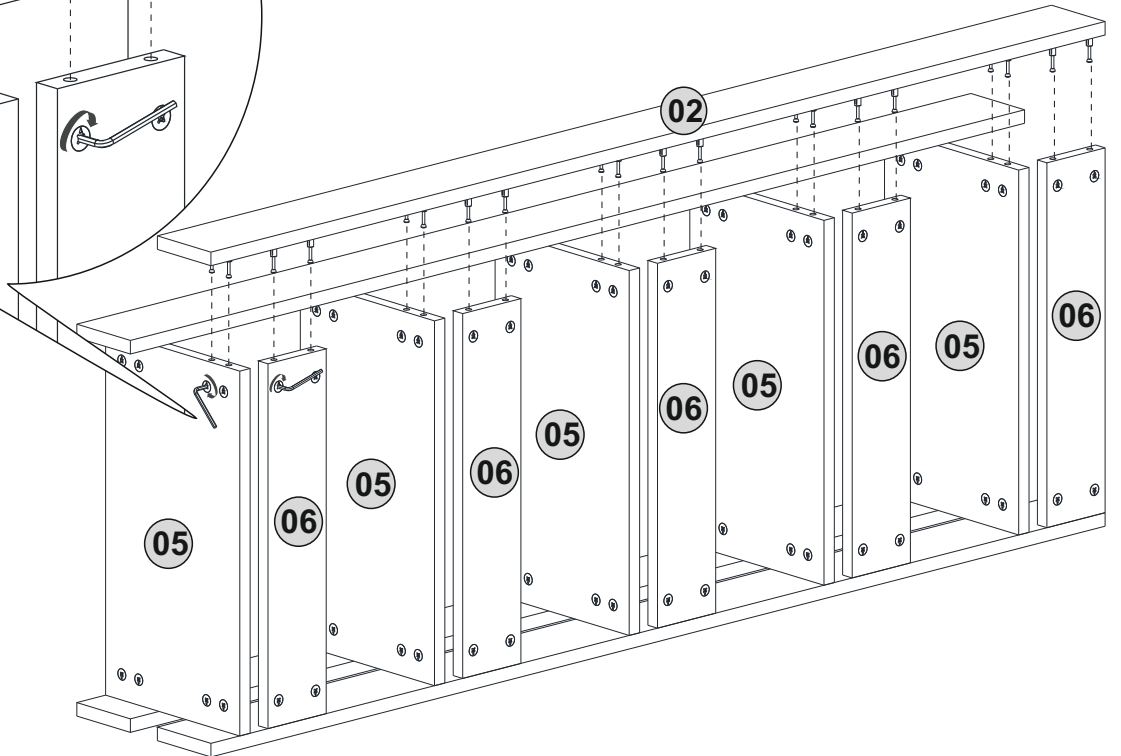
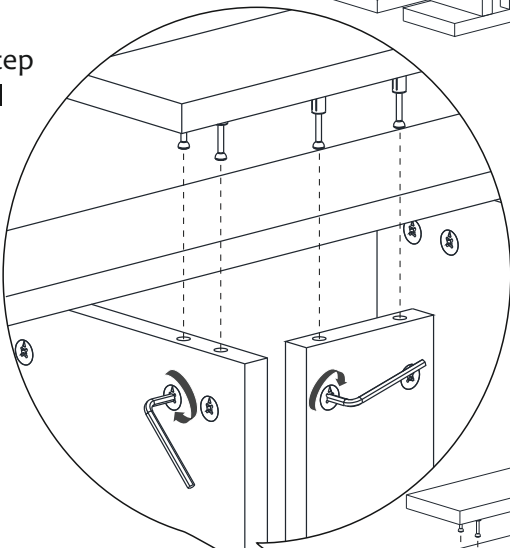

7 step

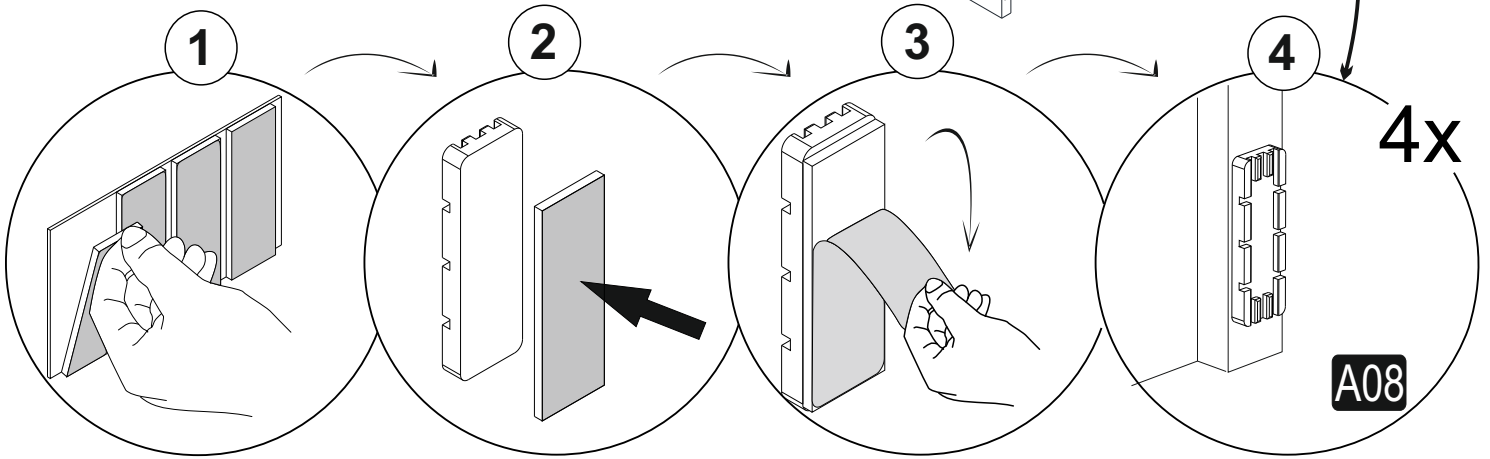
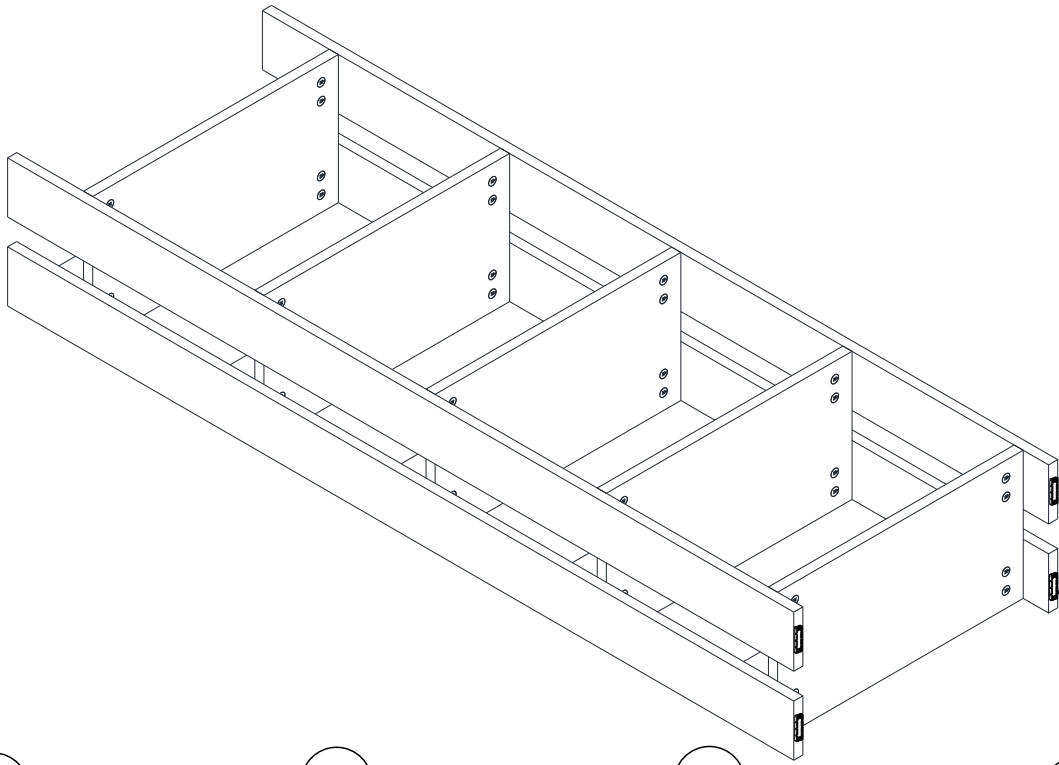

8 step

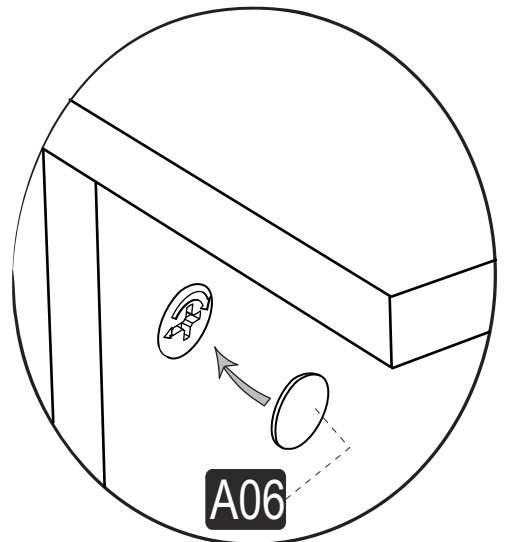
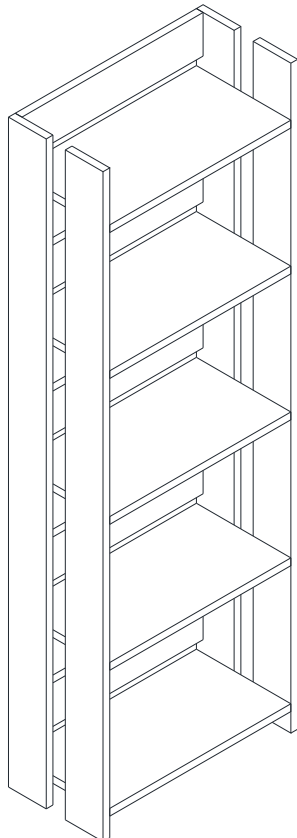

9 step

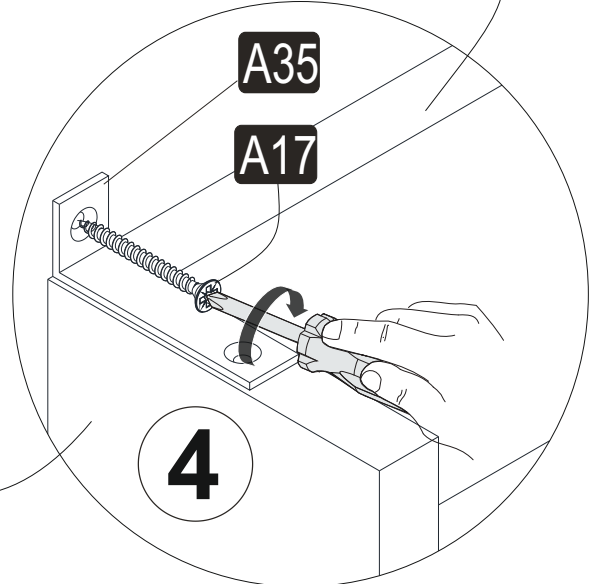
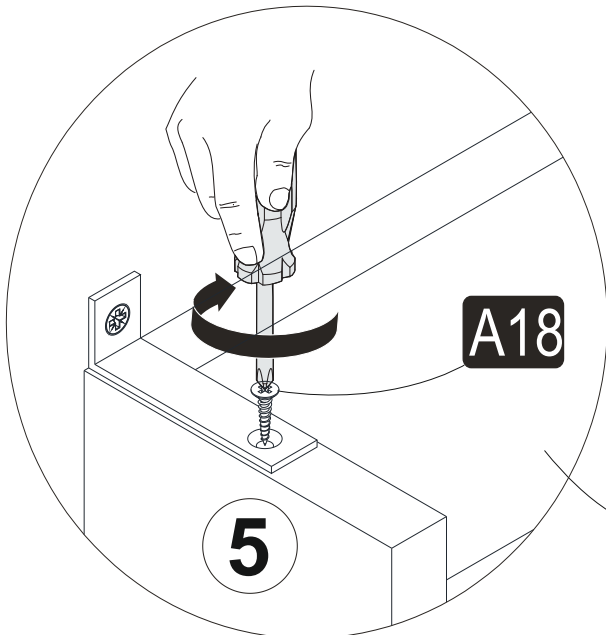
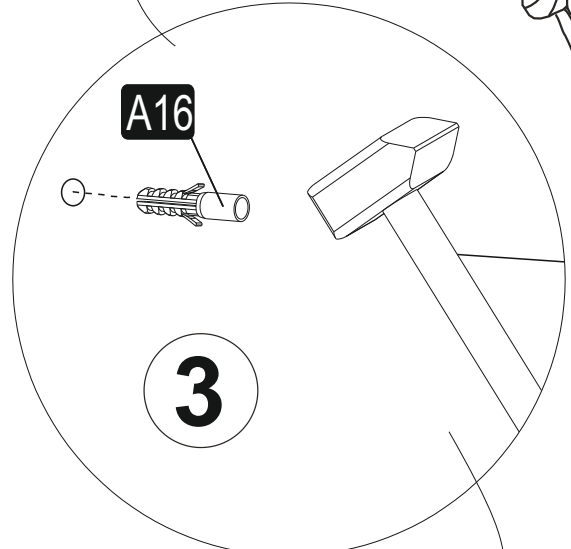
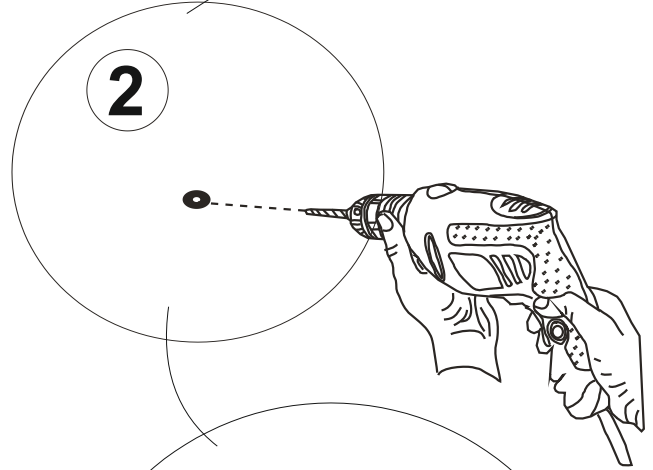
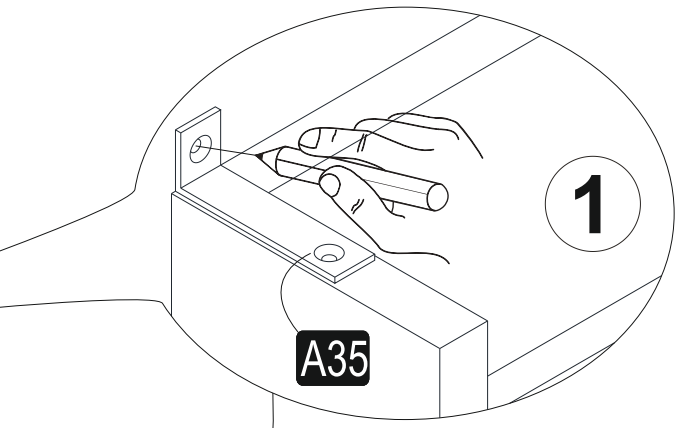
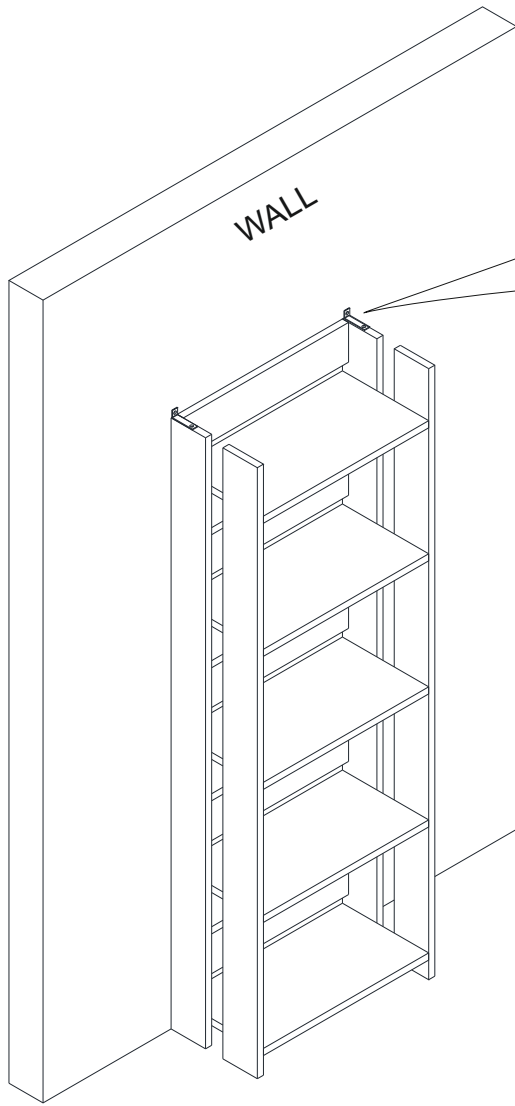

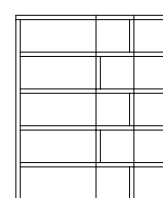
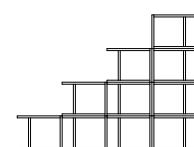
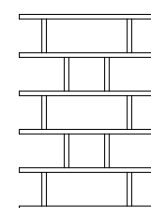
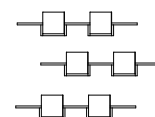
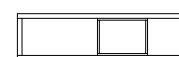
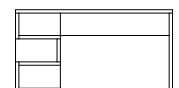
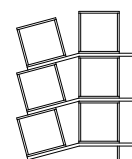
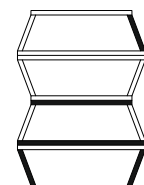
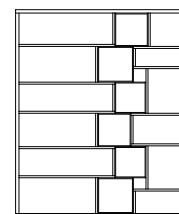

- This unit contains small parts which could be a choking hazard for small children. Children should be under adult supervision at all times.
- Do not overload the unit. Each shelf has a recommended capacity of 13 pounds, and the total weight on the unit should not exceed 39 pounds for wall shelves.
- Do not climb, step, or stand on the unit.
- Do not mount or attach items to the front, rear, or sides of the unit. This can cause the unit to become unbalanced and fall.
- Do not stack units.
- All units must be secured individually to wall studs using hardware provided. If wall studs are not accessible, consult your local hardware store for appropriate mounting hardware.
- We recommend you hand-tighten screws. Use care not to over tighten if using power tools. Follow proper safety procedures if using power tools and/or ladders.
- We recommend you protect your work surface during assembly to prevent scratching or damage to tabletops, wood floors, etc.
- Failure to follow the instructions listed here could result in bodily injury or damage to personal belongings. Use caution and follow safety procedures.