

PATIO COOLER & BEVERAGE CART

If you have any questions about the product, please feel free to contact us.

E-Mail: Patiofurniture Serviceteam@outlook.com

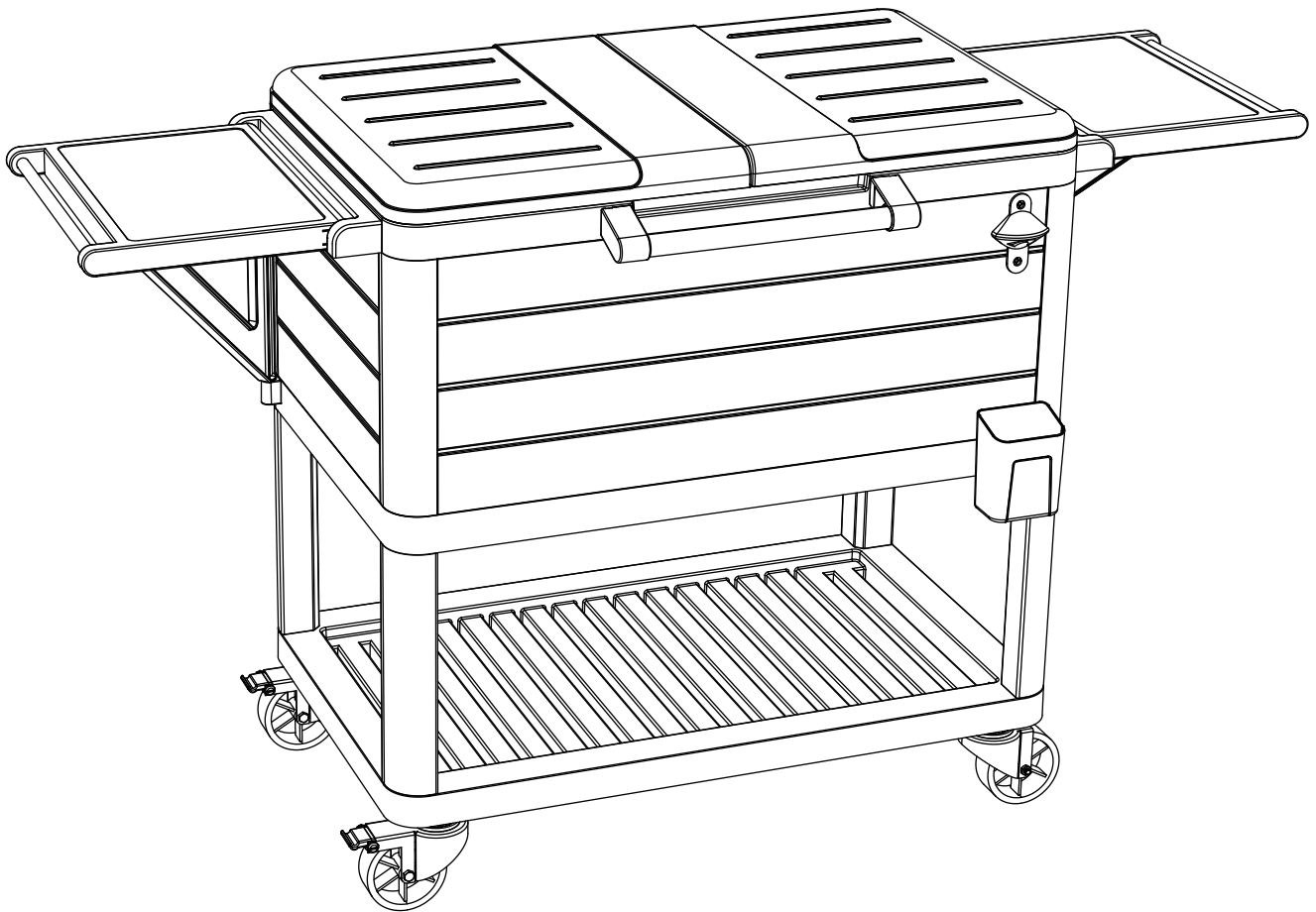

After-sales mailbox:
Patiofurniture Serviceteam@outlook.com

NOTICE



Please retain these instructions for future reference.

Dear Customer

Thank you for your purchase.

When you receive the product, please make sure that all the parts are intact.



Then please browse the entire installation manual before assembly.

If problem occur unsatisfactorily as follows

- A** . The outer box is damaged
- B** . The product is damaged / bent / cracked while you open the box
- C** . The parts / accessories / assembly tools are missing
- D** . The product is hard to assemble
- E** . The instructions are not clear and can not be referred
- F** . The product has functional problems
- G** . Other aspects that you are not satisfied with







Please do not hesitate to contact us for help. Our team with factory direct after-sales service will reply within 24 hours and will do our best to resolve the problem for you.

HARDWARE LIST

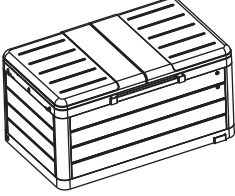
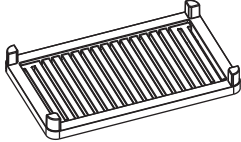
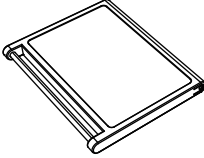
<p>①</p>  <p>5*20 mm Bolt</p>	<p>②</p>  <p>4*25 mm Bolt</p>
<p>18 pc</p>	<p>4 pc</p>

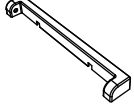
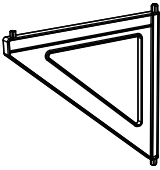
PART LIST

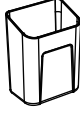
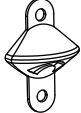
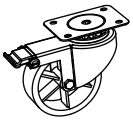
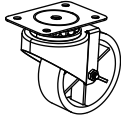
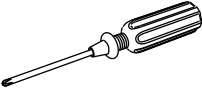
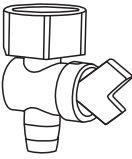
Parts List

				
1 pc	1 pc	2 pc	4 pc	2 pc
				
2 pc	1 pc	1 pc	1 pc	1 pc
				
2 pc	2 pc	1 pc	1 pc	1 pc

1. Please ensure that all accessories are complete before starting the installation.
2. Due to the variety of accessories, many accessories may be glued together, please check carefully.
3. If any accessories are missing or damaged, please contact the seller immediately.

E-Mail: Patiosfurniture Serviceteam@outlook.com

STEP 1

Do the same thing on the other side

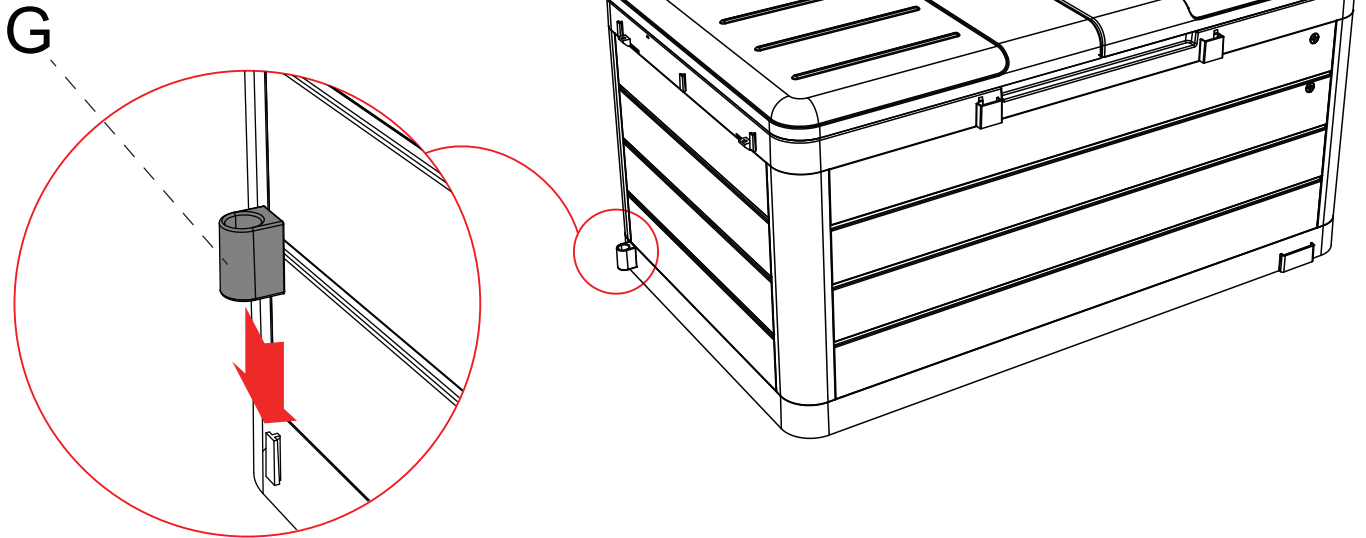
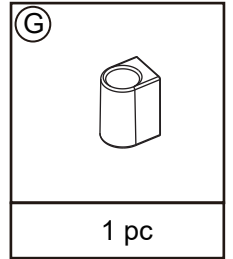

STEP 2

Do the same thing on the other side

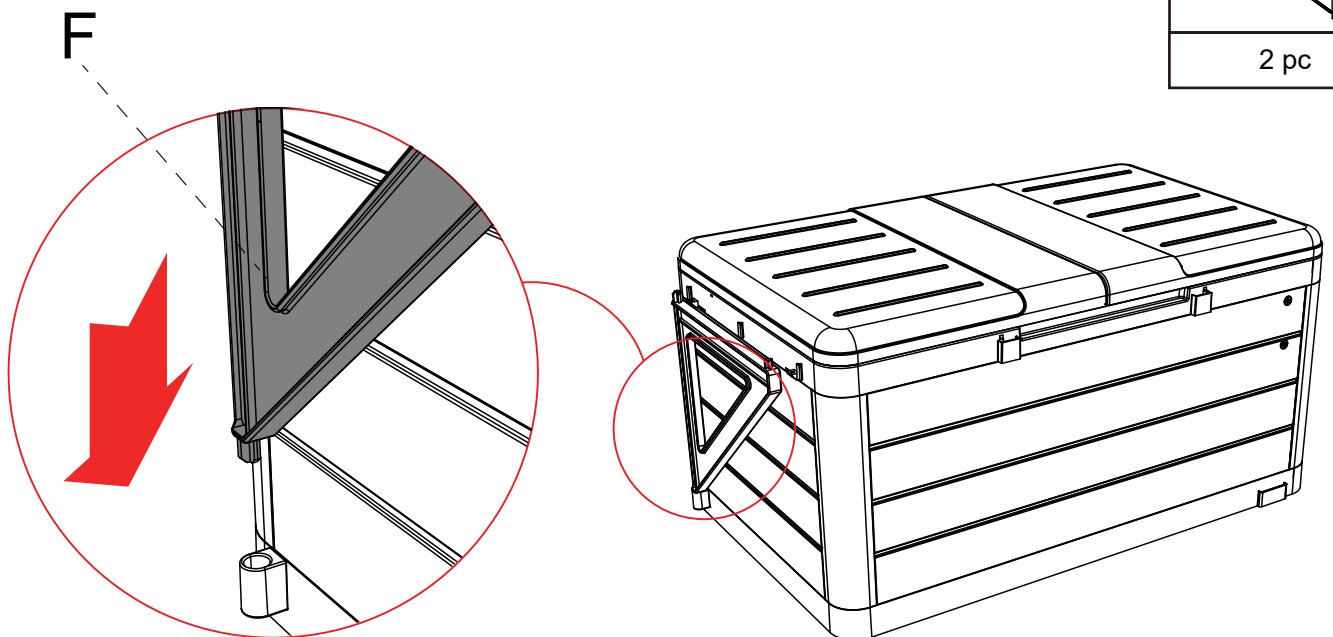
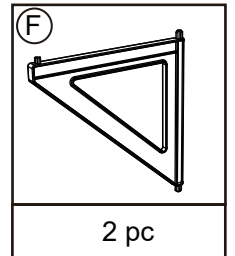

STEP 3

Do the same thing on the other side

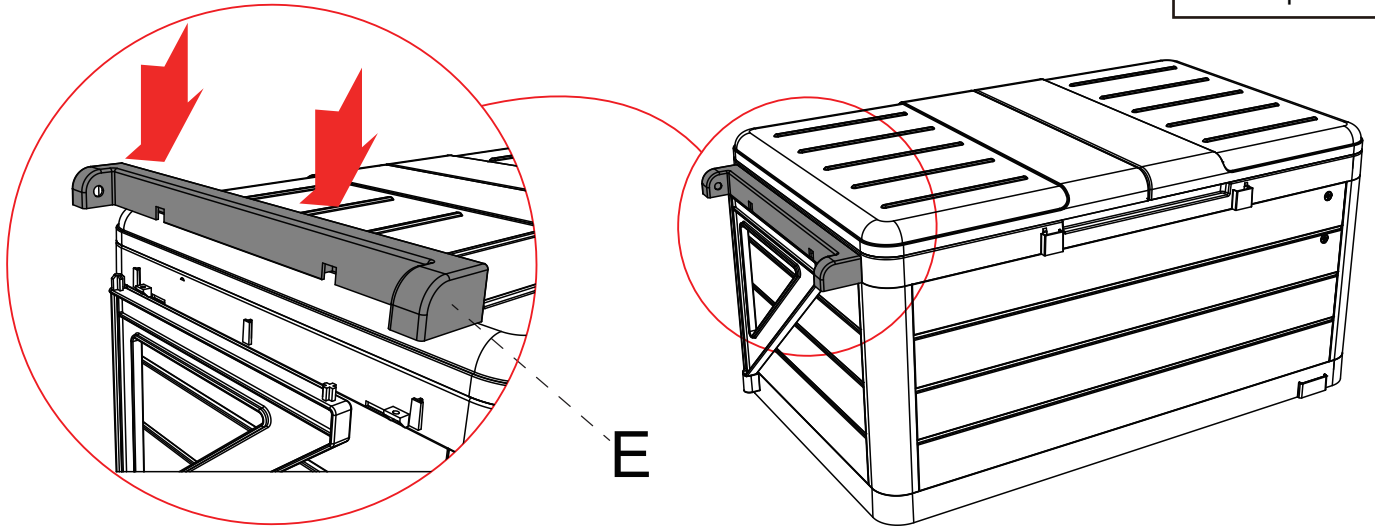
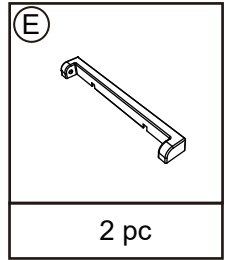

STEP 4

Do the same thing on the other side

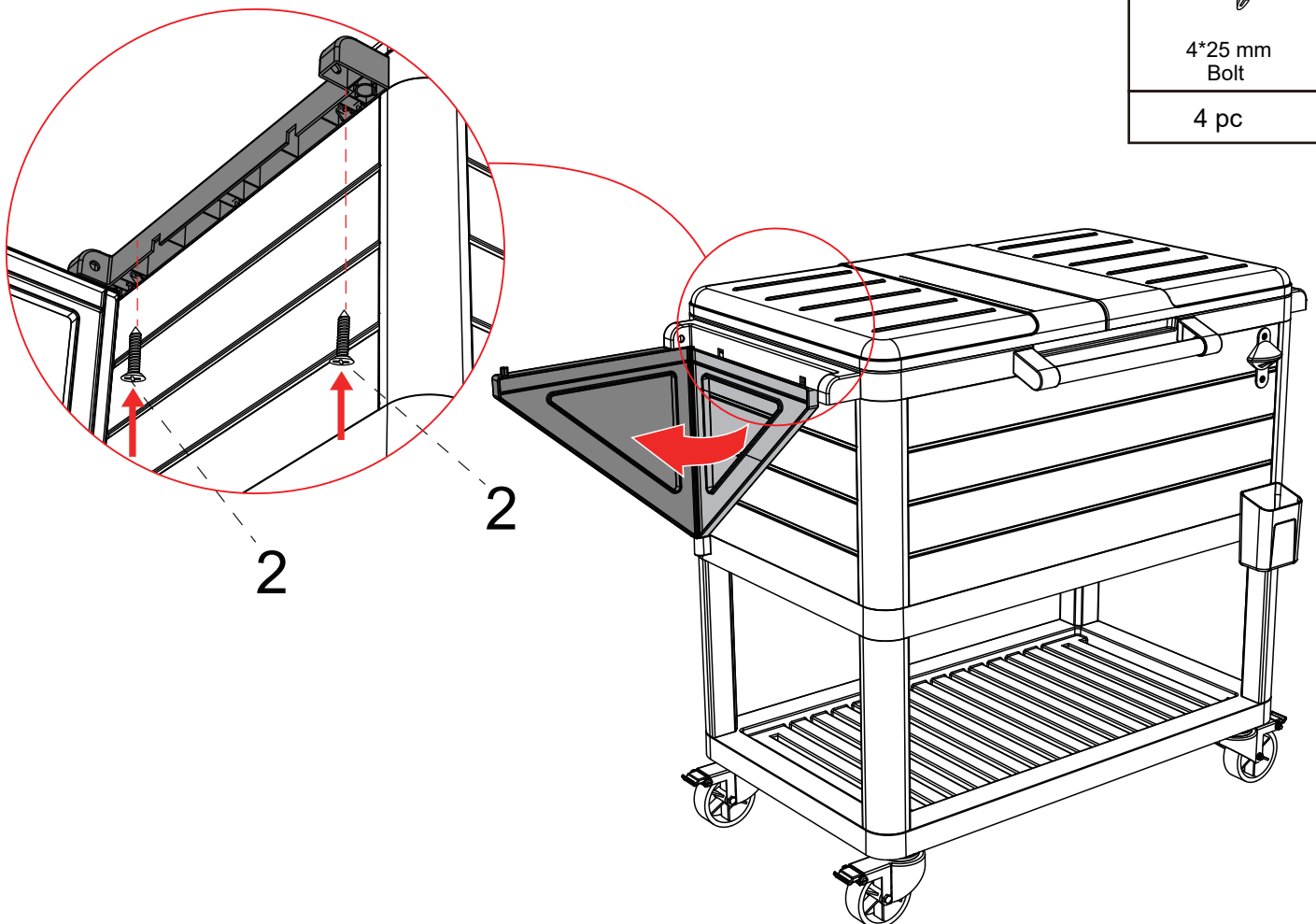
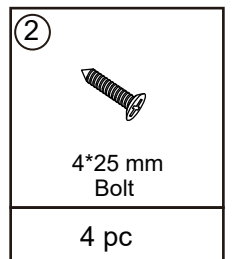

STEP 5

Do the same thing on the other side

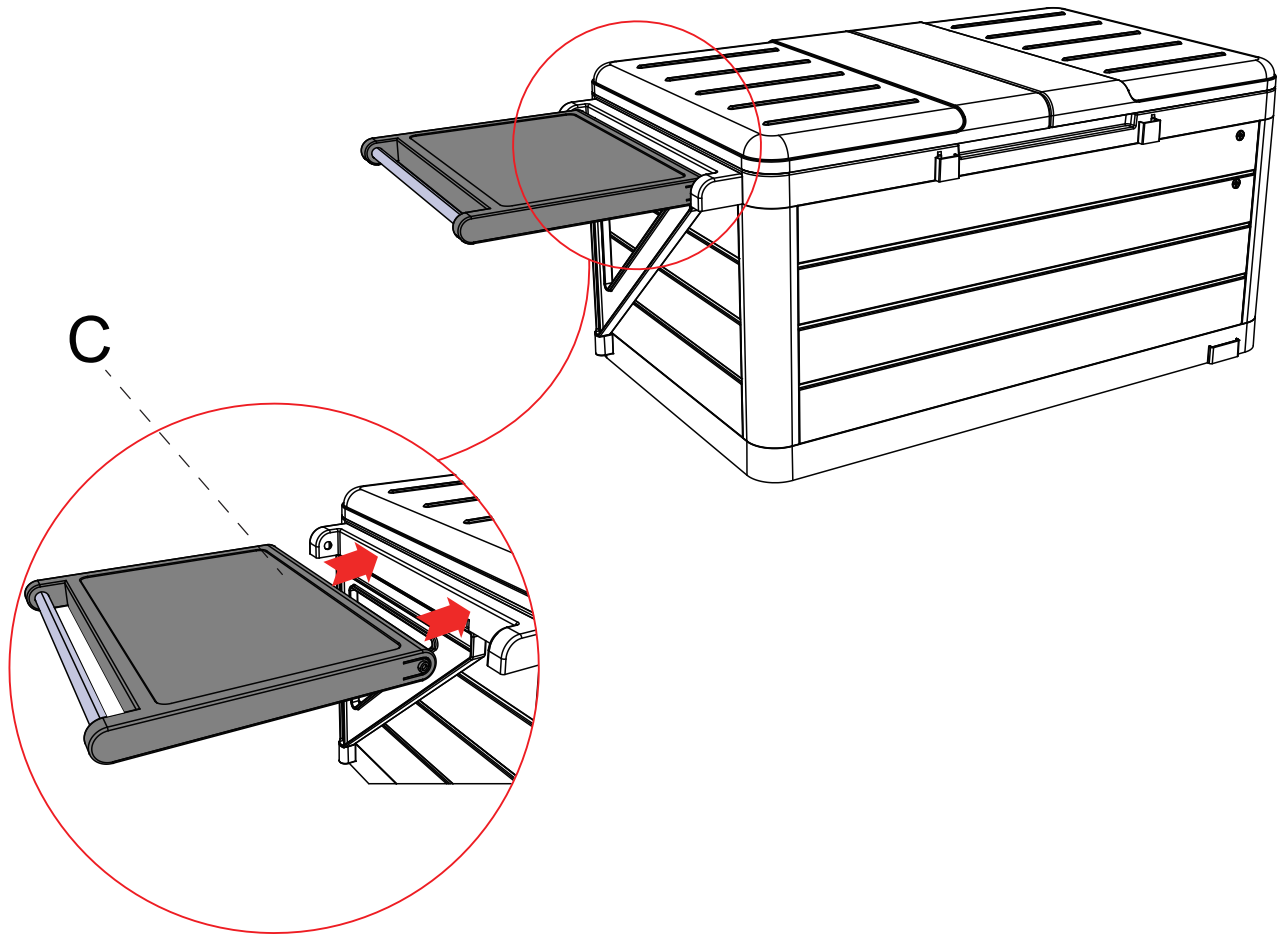
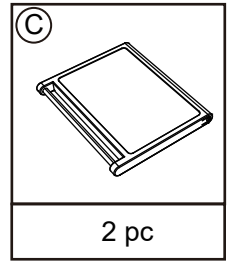

STEP 6

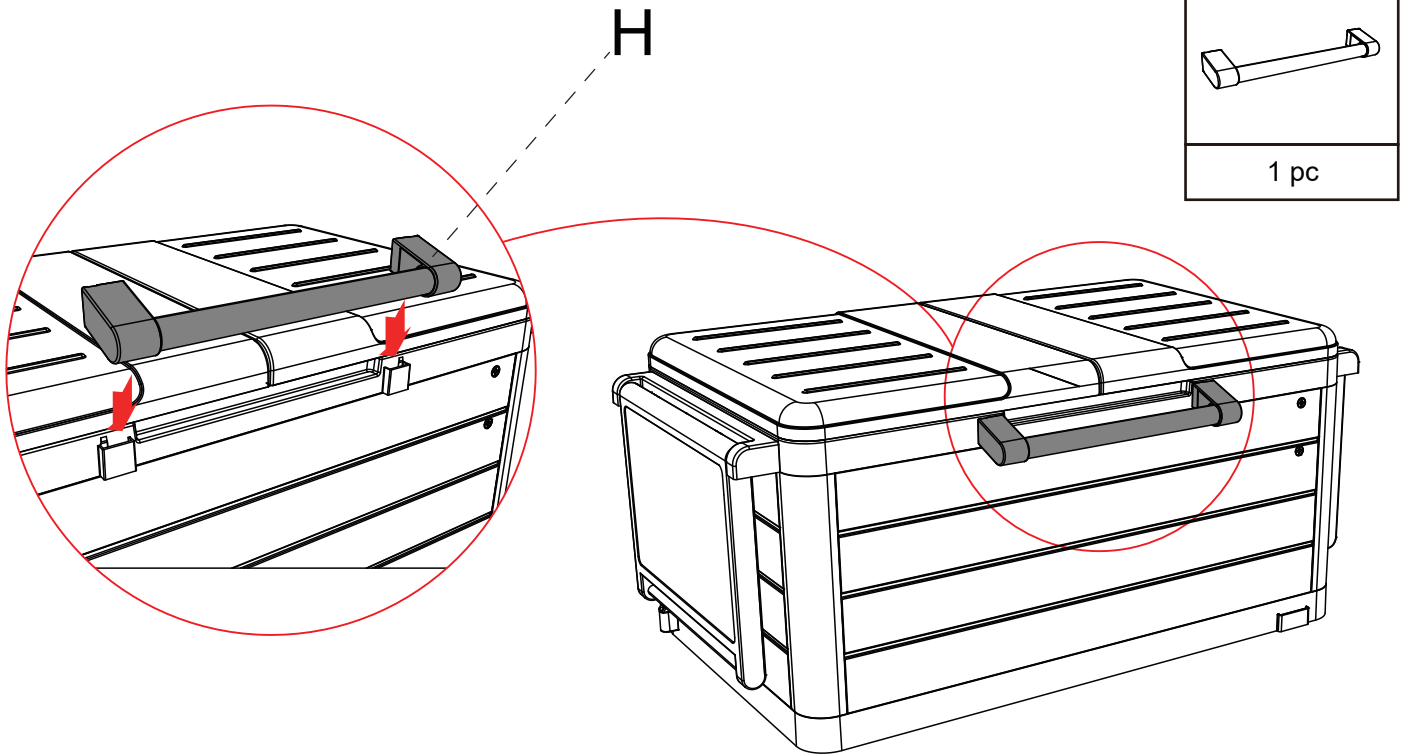

STEP 7

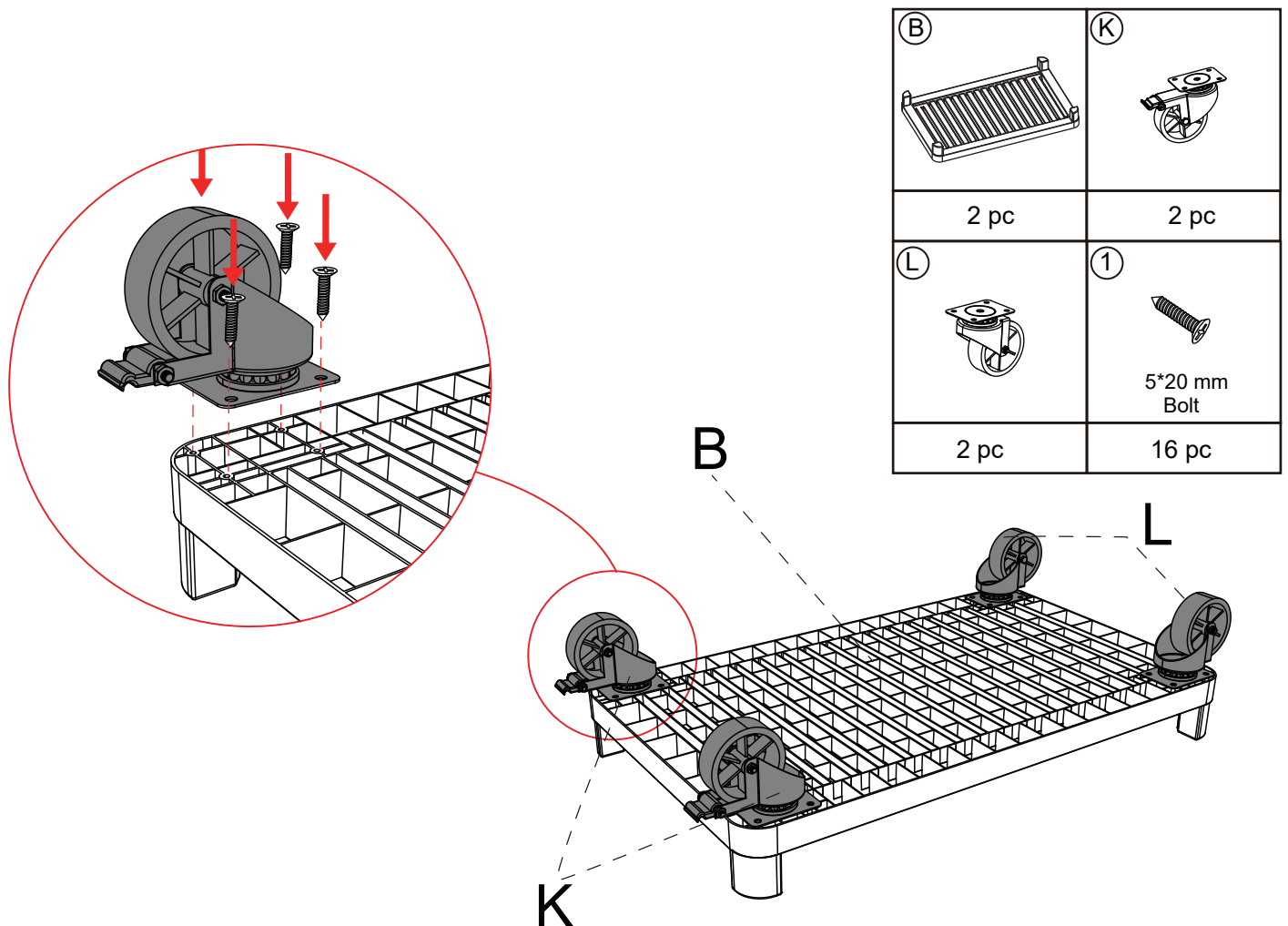

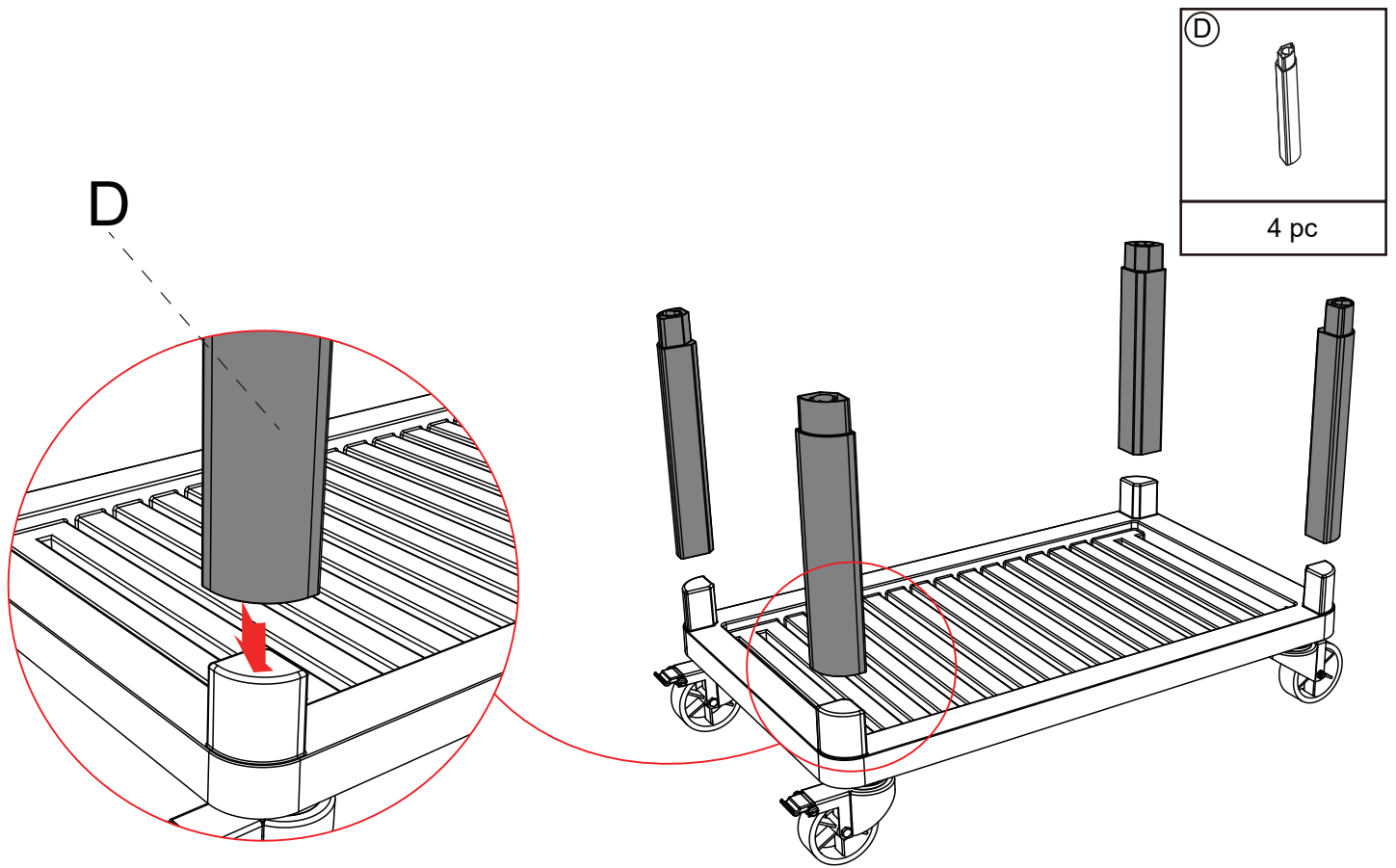

STEP 8

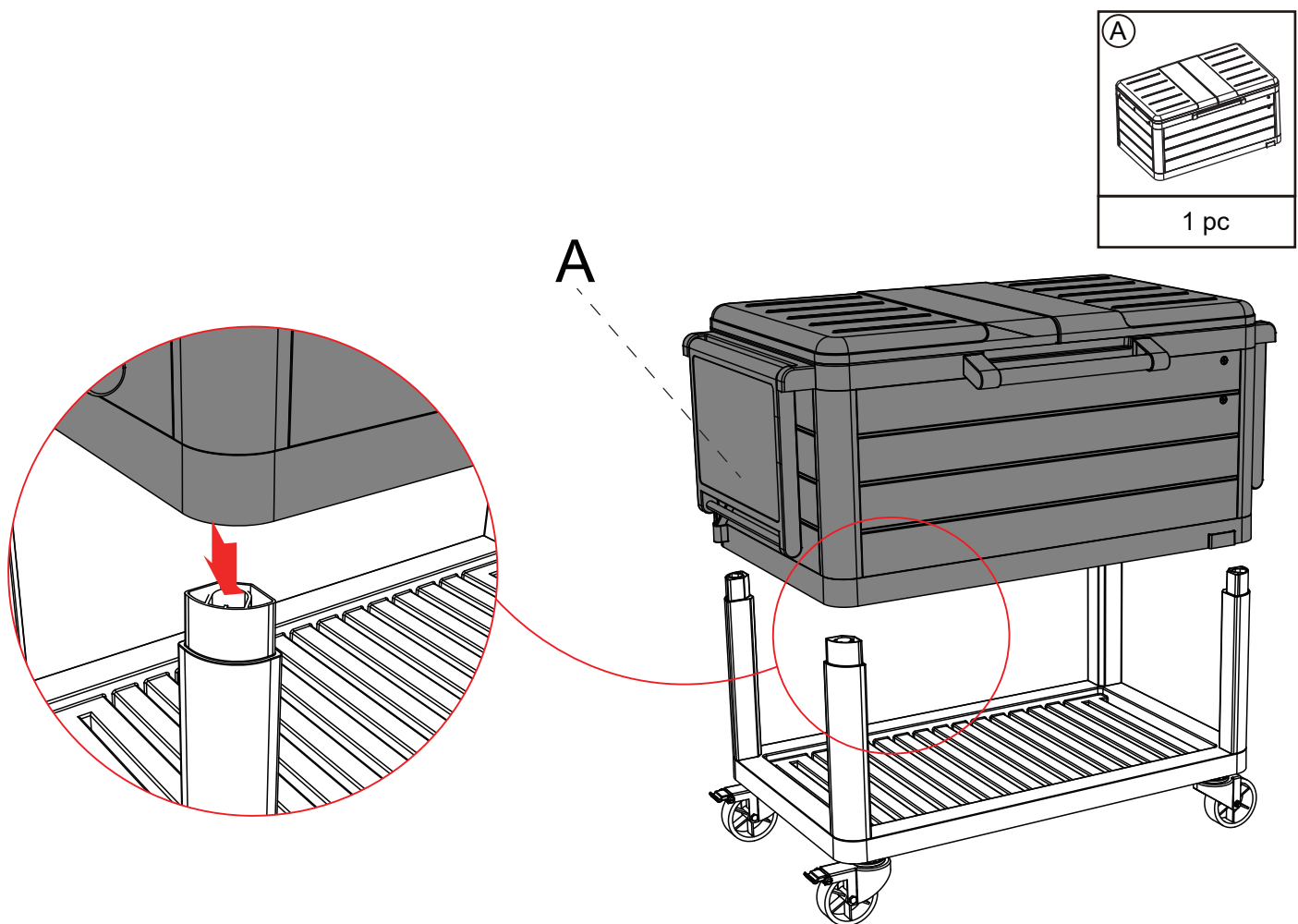

STEP 9

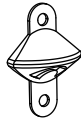

STEP 10

 J	 1 5*20 mm Bolt
1 pc	2 pc

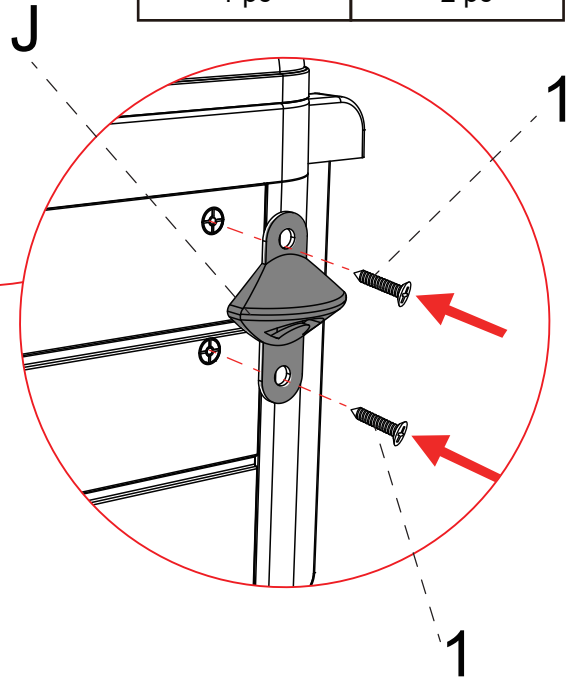
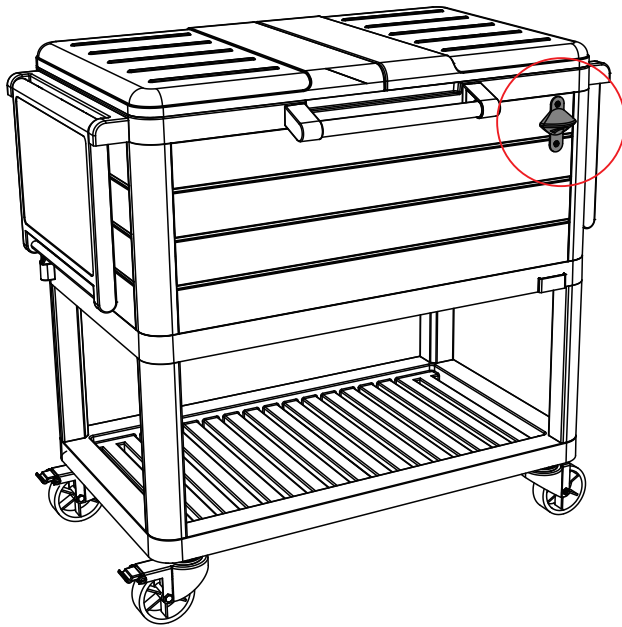

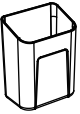

STEP 11

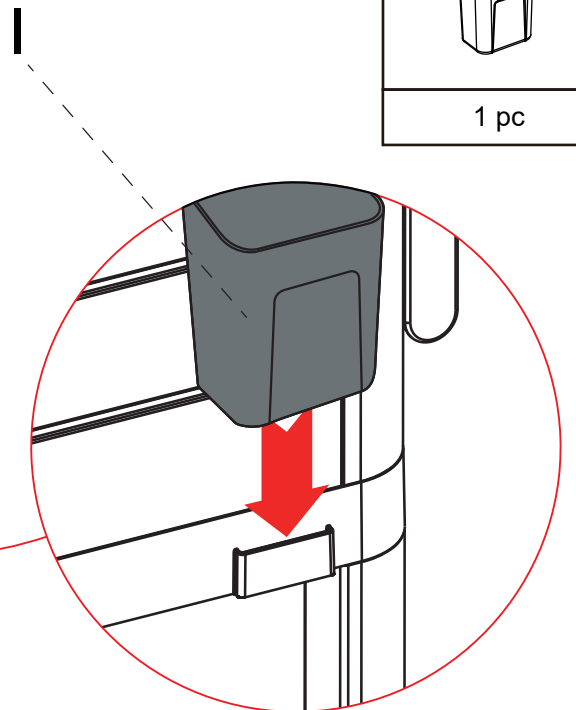
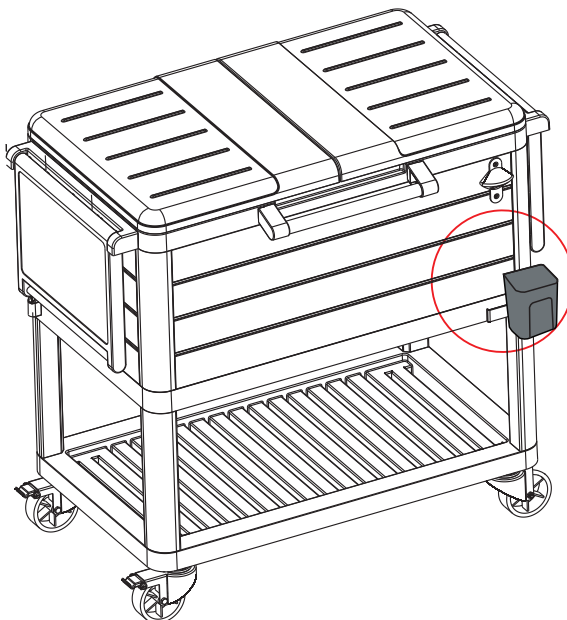
 I
1 pc

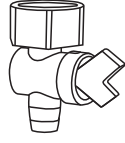

STEP 12

N 	O 
1 pc	1 pc

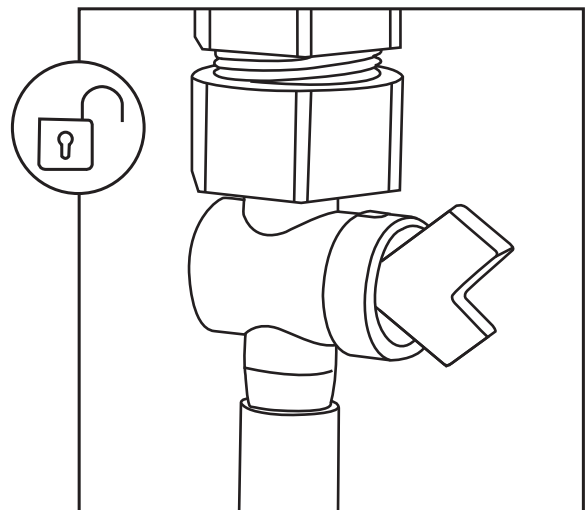
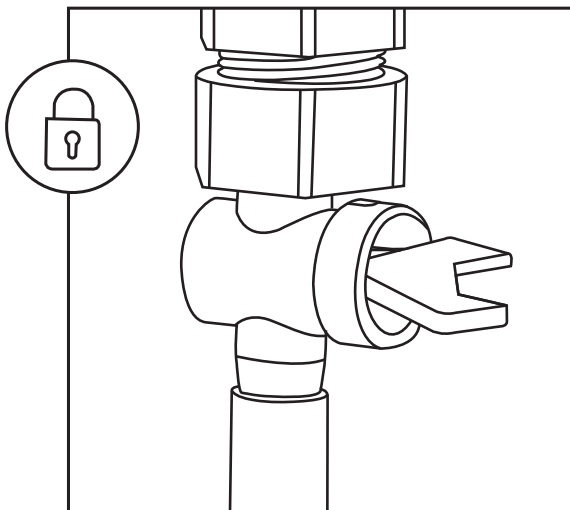
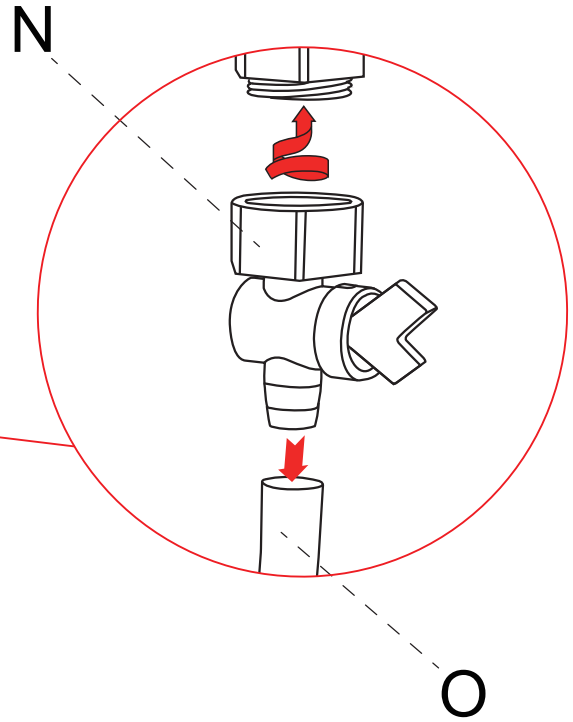
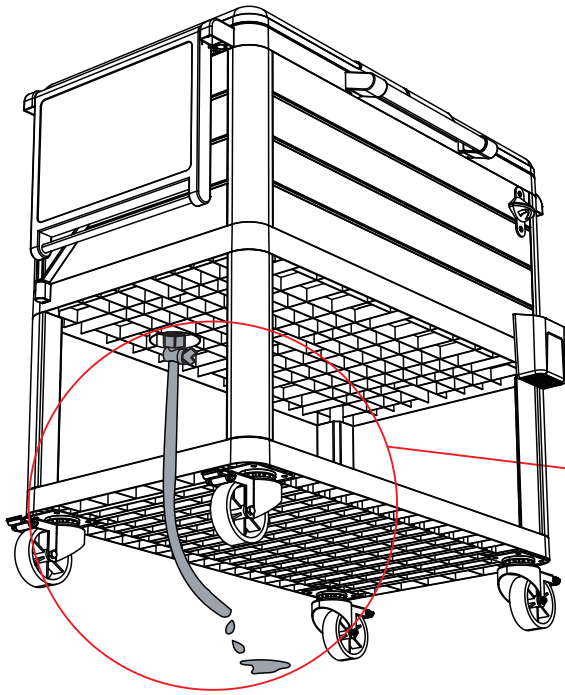

STEP 13

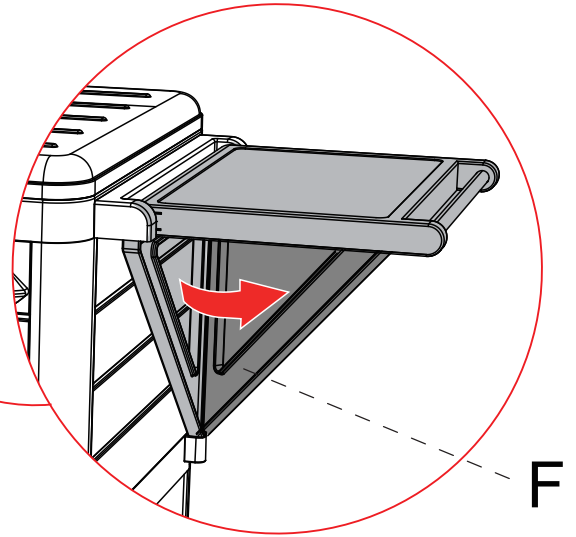
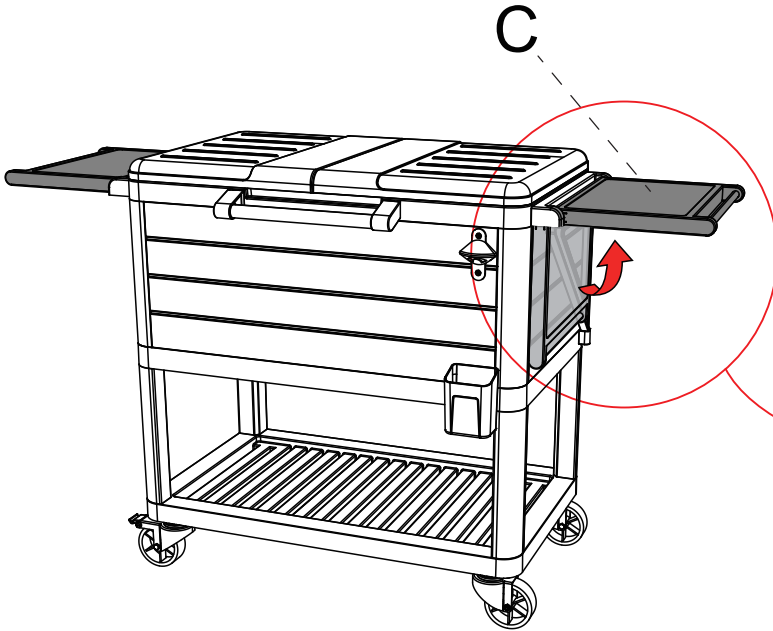
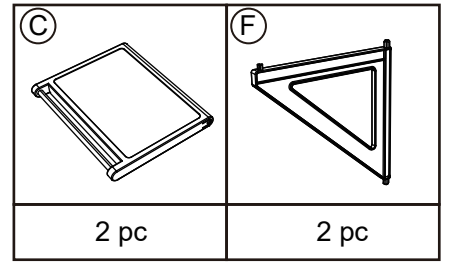

STEP 14

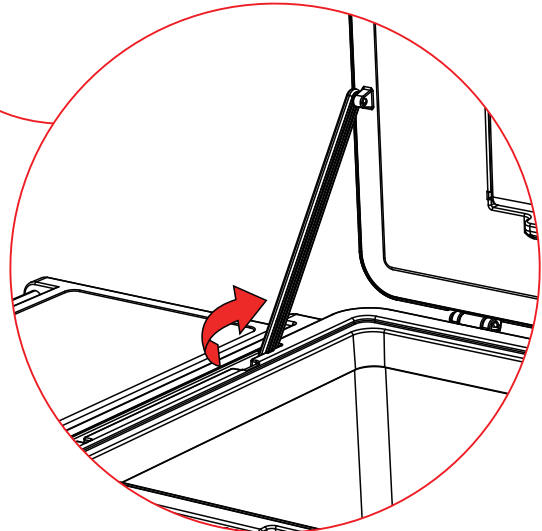
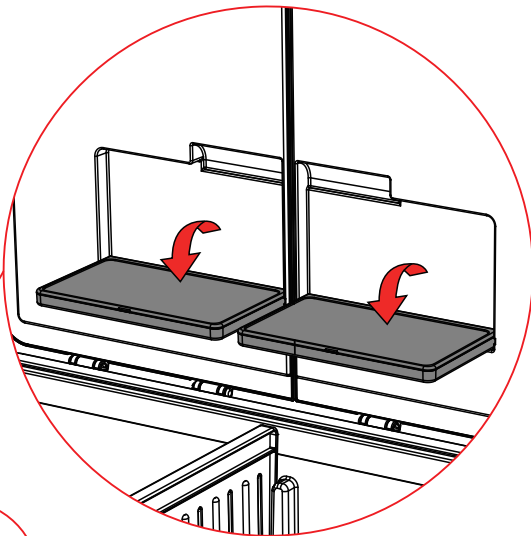
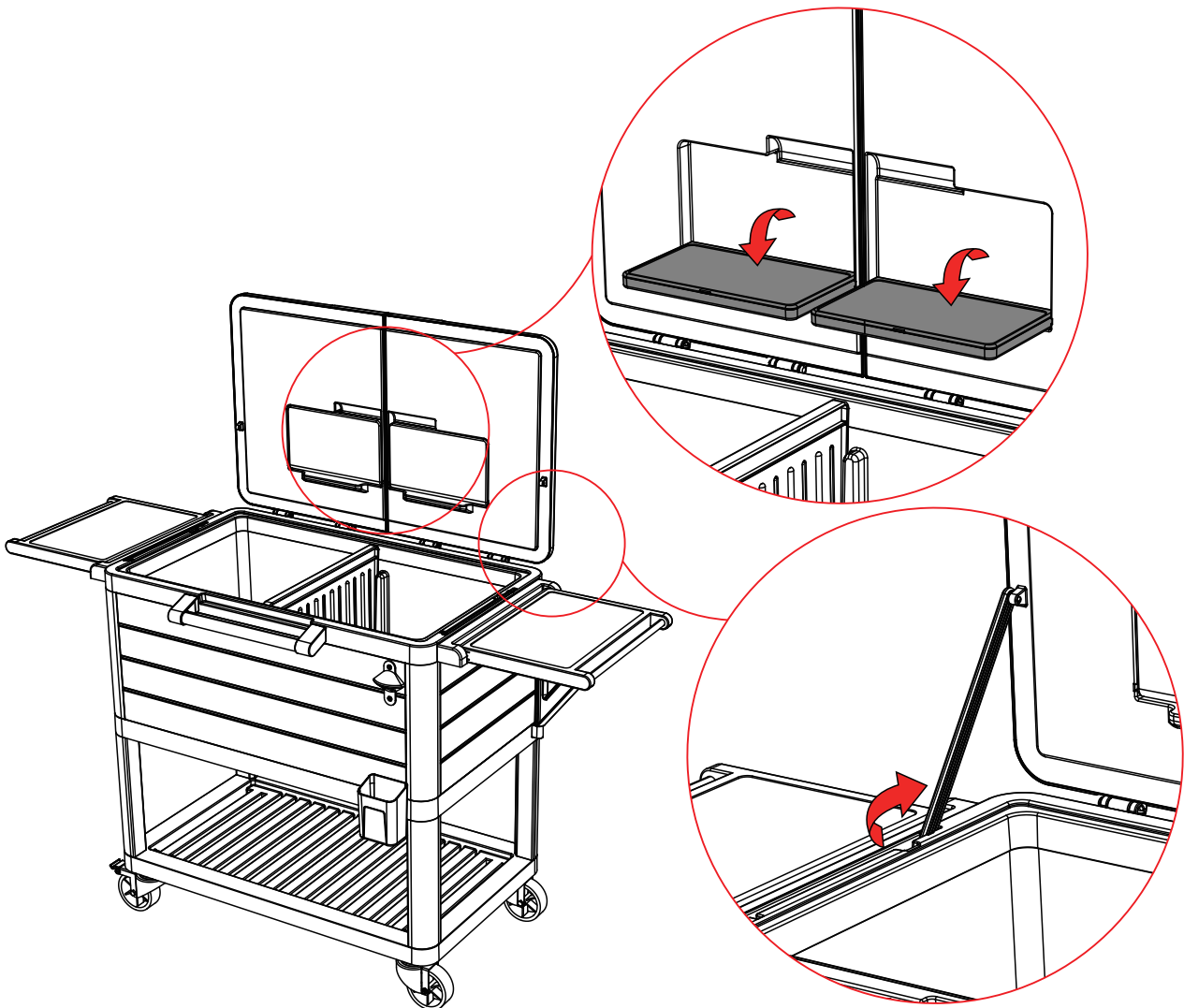

STEP 15

The installation is complete.
Make sure all the screws are fully tighten.

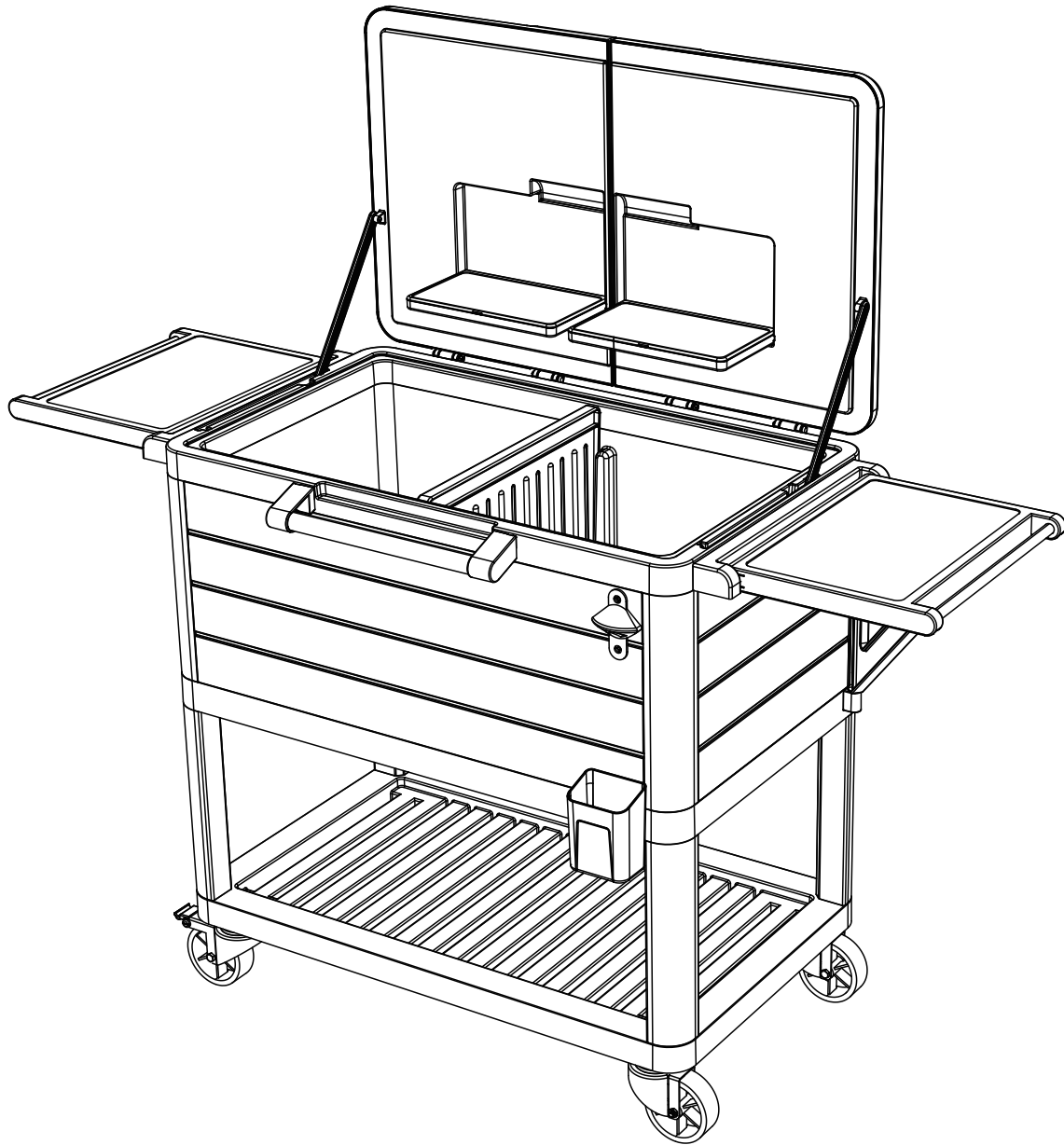

AFTER-SALE SERVICE CARD

If you have any suggestions for our products or find that the products have quality problems, please contact us first, our after-sales team will reply you within 24 hours, and we will do our best to give you solutions until you are satisfied.

Guaranteed Customer Service

Your shopping experience is very important to us!
Feel unsatisfied? **Contact us!**
Have any questions? **Contact us!**

Wanna share how wonderful our smart products makes your home?
Share your pictures with us.
Any suggestions? **Contact us!**
We gotcha back!

 Patiofurniture Serviceteam@outlook.com

