







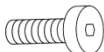

ASSEMBLY INSTRUCTION

*** Do not fully tighten screws until fully assembled ***

COMPONENT PARTS			
DESCRIPTION	PARTNAME	Q'TY(PCS)	
A	Upper part of Standing chair	1	
B	lower part of Standing chair	1	
C	Support of Standing chair	1	

HARDWARE REQUIRED

D		BOLT	Φ 6*40mm	4	PCS
E		BOLT	Φ 6*45mm	4	PCS
F		NUT	Φ 6mm	4	PCS
G		SHIM	Φ 6mm	12	PCS
H		SPANNER	M6mm	1	PC
I		SPANNER		1	PC
J		CUSHION		1	PC

Attention

***Some number parts listed on the instruction sheet may not be in parts bag as they may already be assembled.

Carefully check parts and packing material prior to ordering replacements.

How to assemble:

1

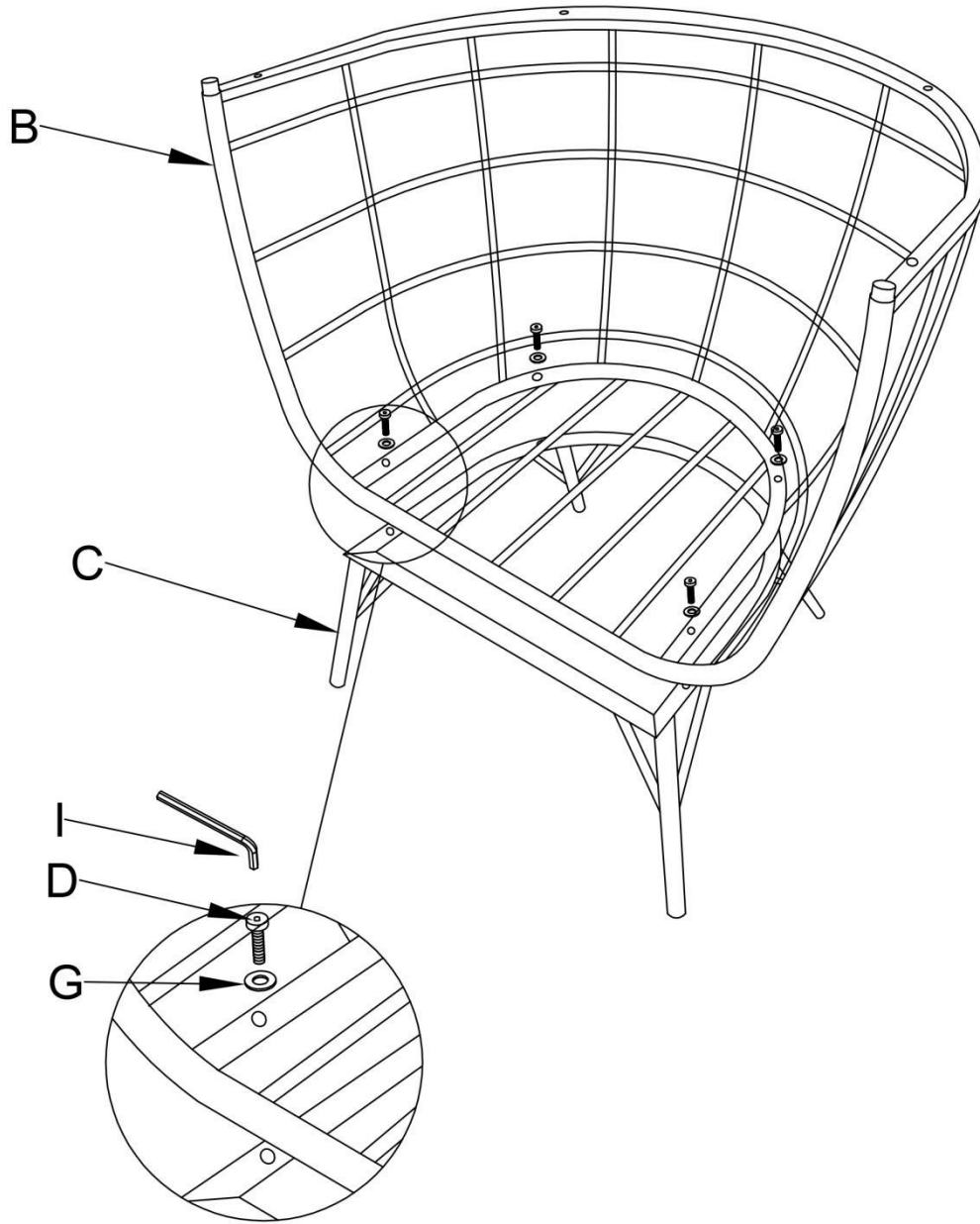

2

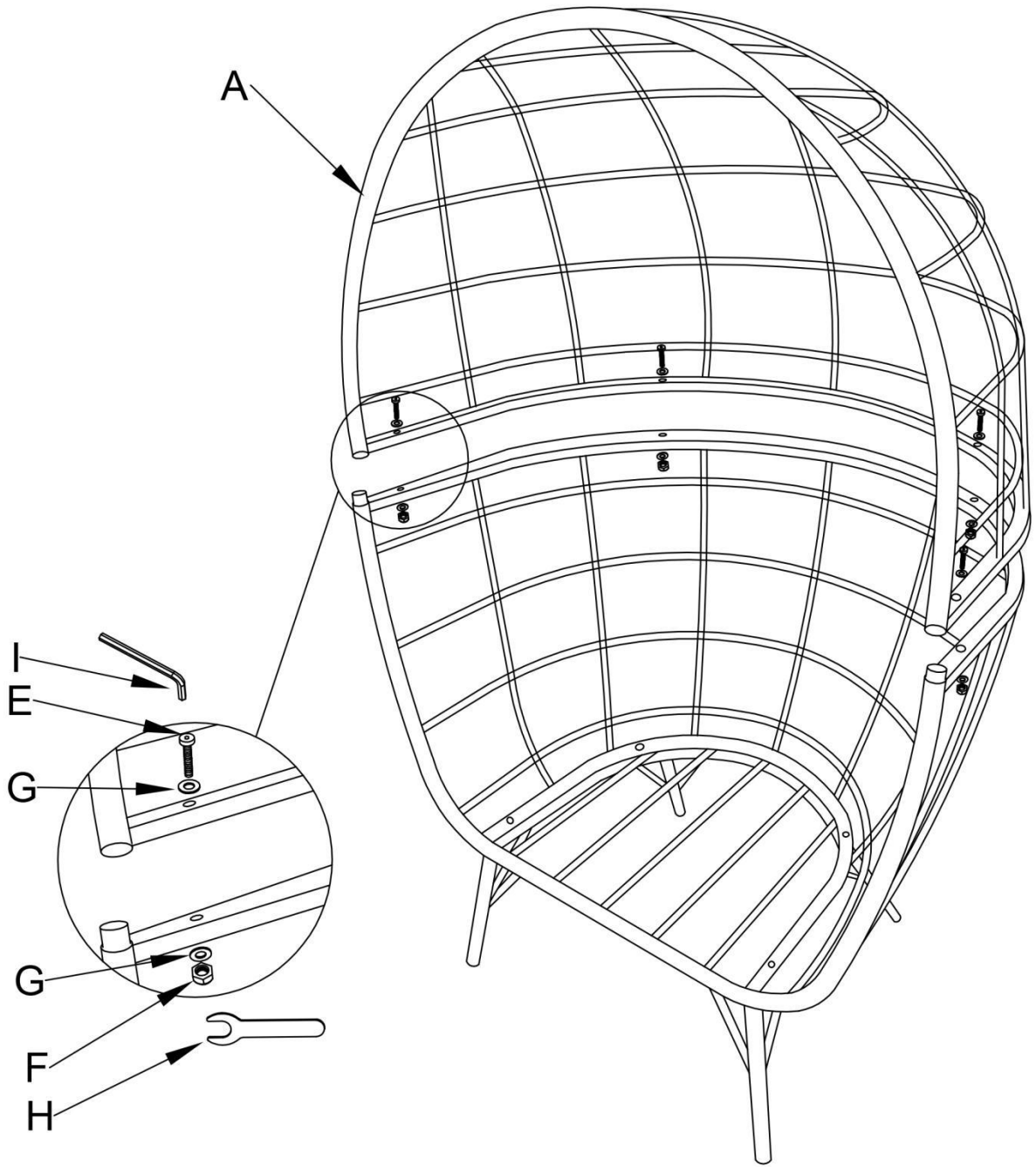

3

