

# ASSEMBLY INSTRUCTIONS

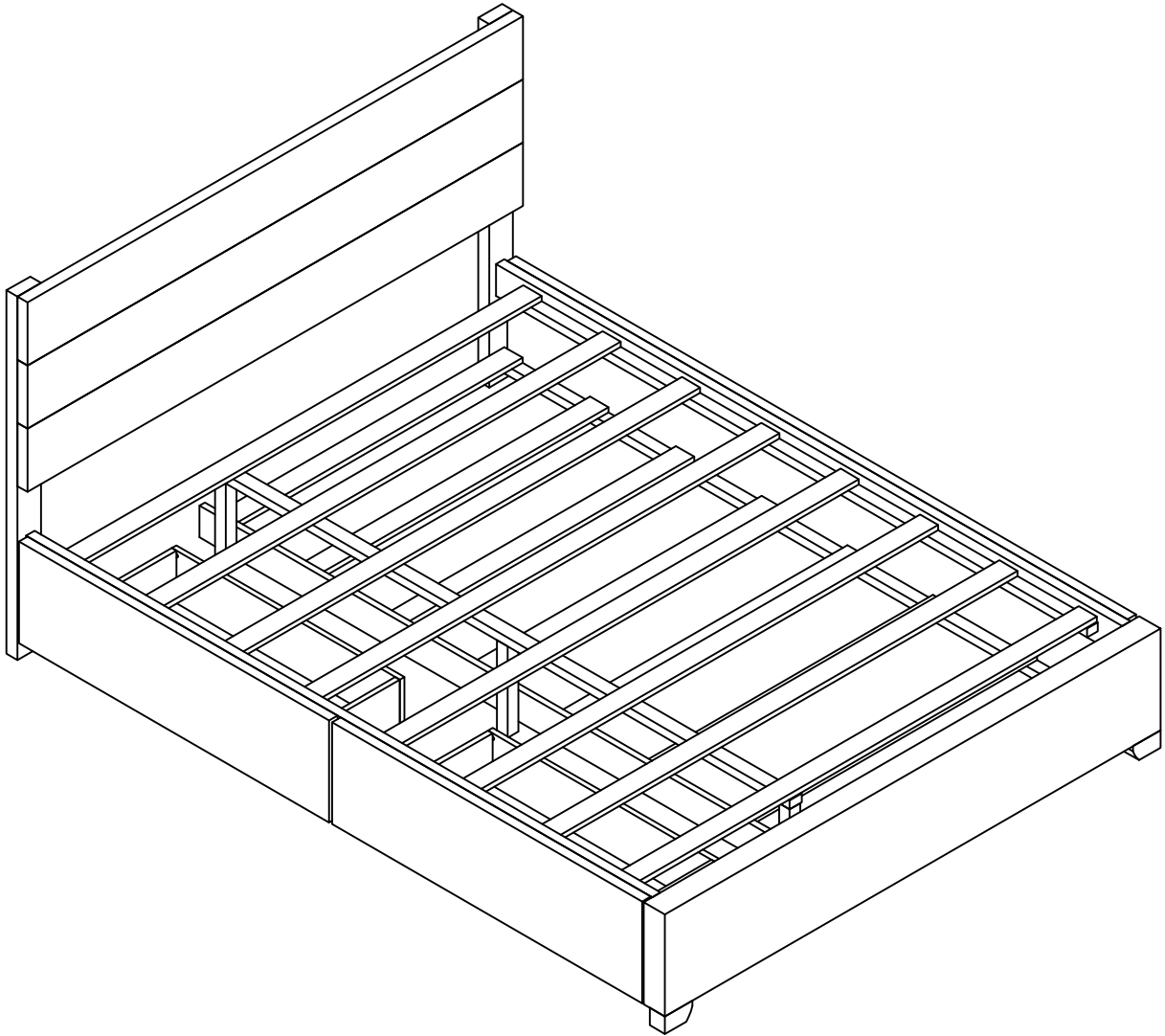

## IMPORTANT NOTE









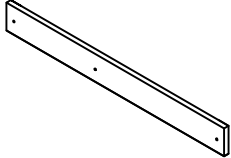

**\*\*PLACE ALL PARTS ON A CLEAN AND SMOOTH SURFACE SUCH AS A RUG OR CARPET TO AVOID THE PARTS FROM BEING SCRATCHED**

**\*\* BEFORE YOU BEGIN , KINDY FOLLOW THE ASSEMBLY INSTRUCTIONS STEP BY STEP**

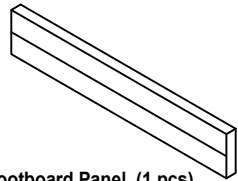
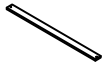

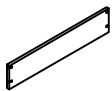
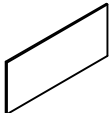
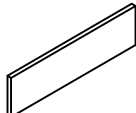

**\*\*DO NOT TIGHTEN ALL SCREWS AND BOLTS UNTIL THE BED IS FULLY SET-UP**

# ASSEMBLY INSTRUCTIONS

## PART LIST BOX 1

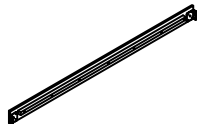
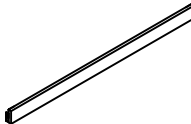
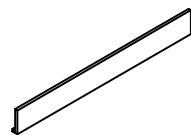

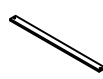



<b>1</b>  Lower Bed Panel (3 pcs)	<b>2</b>  Connection Bar (1 pc)	
<b>3</b>  Left Metal Plate (1 pc)	<b>4</b>  Right Metal Plate (1 pc)	<b>5</b>  Footboard Panel (1 pcs)
<b>6</b>  Roll Slat (8 pcs) 1365*60*15	<b>7</b>  Leg (2 pcs)	<b>8</b>  Left Wheel Board (2pcs)
<b>9</b>  Right Wheel Board (2 pcs)	<b>10</b>  Stand in Pull Box (4pcs)	<b>11</b>  Side Pull Box (4pcs)
<b>12</b>  Back Panel Pull Box (2 pcs)	<b>13</b>  Pull Box Bottom Board (2 pcs)	<b>14</b>  Pull Box Bottom Board (2pcs)

## PART LIST BOX 2:

<b>15</b>  Left Lower Rail (1 pc)	<b>16</b>  Right Lower Rail (1pc)	<b>17</b>  Front Panel Trundle (1 pc)
<b>18</b>  Back Panel Trundle (1 pc)	<b>19</b>  Roll Slat (8 pcs) 985*60*15	<b>20</b>  Center Rail (1 pc)
<b>21</b>  Bed Slat Support With Leveler (3 pcs)		

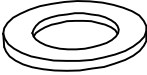
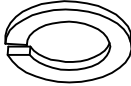
# ASSEMBLY INSTRUCTIONS

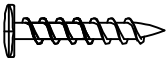
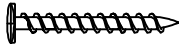
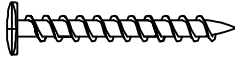

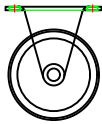

## HARDWARE LIST

<p><b>A</b></p>  <p>(<math>\varnothing</math> 5/16 "X25mm) <b>Short Bolt (8pcs)</b></p>	<p><b>B</b></p>  <p>(<math>\varnothing</math> 5/16 "X38mm) <b>Long Bolt (9 pcs)</b></p>	<p><b>C</b></p>  <p>(<math>\varnothing</math> 5/16 "X55mm) <b>Long Bolt (2 pcs)</b></p>
<p><b>D</b></p>  <p>(<math>\varnothing</math> 5/16 "-RBW) <b>Flat Washer (19 pcs)</b></p>	<p><b>E</b></p>  <p>(<math>\varnothing</math> 5/16 "-RBW) <b>Spring Washer (19 pcs)</b></p>	<p><b>F</b></p>  <p>(M4x75mm x32mm) <b>Allen Wrench (1 pc)</b></p>
<p><b>G</b></p>  <p>( m4x20mm-RBW) <b>Flat Head Screw (72 pcs)</b></p>	<p><b>H</b></p>  <p>( m4x30mm-RBW) <b>Flat Head Screw (44 pcs)</b></p>	<p><b>I</b></p>  <p>( m4x38mm-RBW) <b>Flat Head Screw (24 pcs)</b></p>
<p><b>J</b></p>  <p>( 38mmx38mmx25mmx2mm) <b>Square Patch (4 pcs)</b></p>	<p><b>K</b></p>  <p>(<math>\varnothing</math>10x10mmx10mm) <b>Plastic Button (24 pcs)</b></p>	<p><b>L</b></p>  <p>( m41x25mmx50mm) <b>Wheels (12 pcs)</b></p>

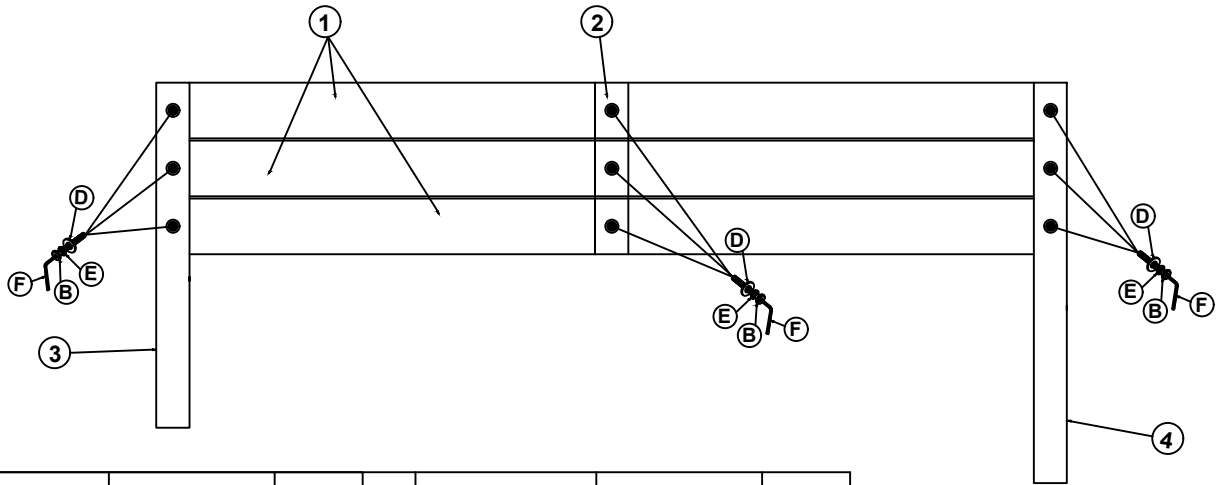
# ASSEMBLY INSTRUCTIONS





## STEP 1

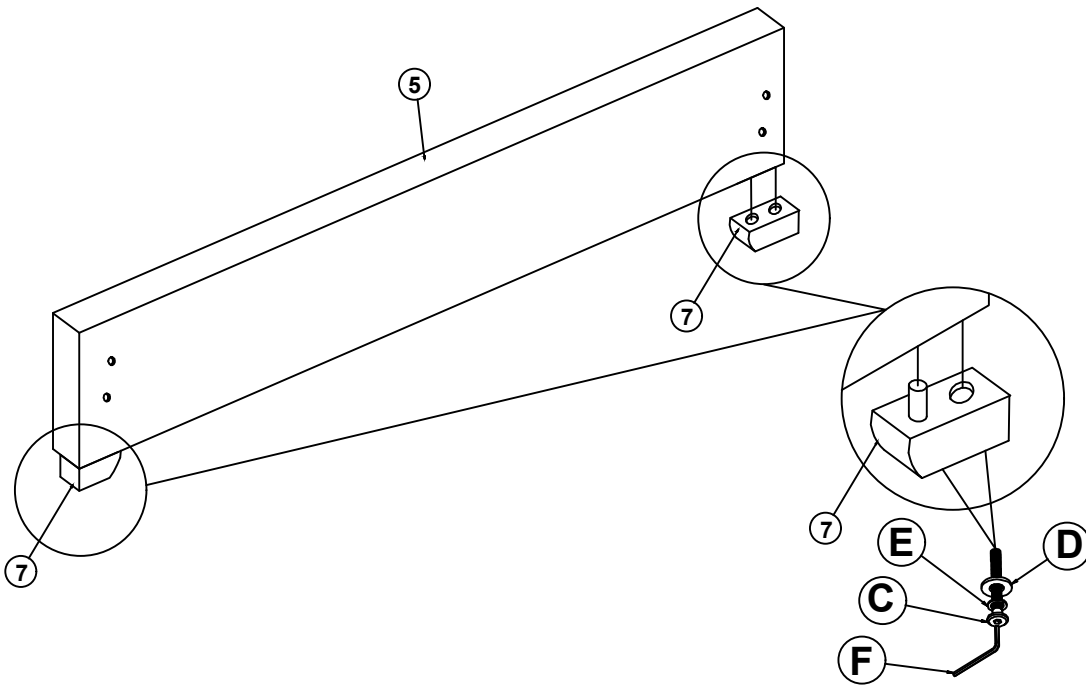

B	<b>Bolt</b> (Ø 5/16 "X38mm)		9pcs	D	<b>Flat Washer</b> (Ø 5/16 "RBW)		9pcs
E	<b>Spring Washer</b> (Ø 5/16 "RBW)		9pcs	F	<b>Allen Wrench</b> (M4x75mm x32mm)		1pc

## STEP 2





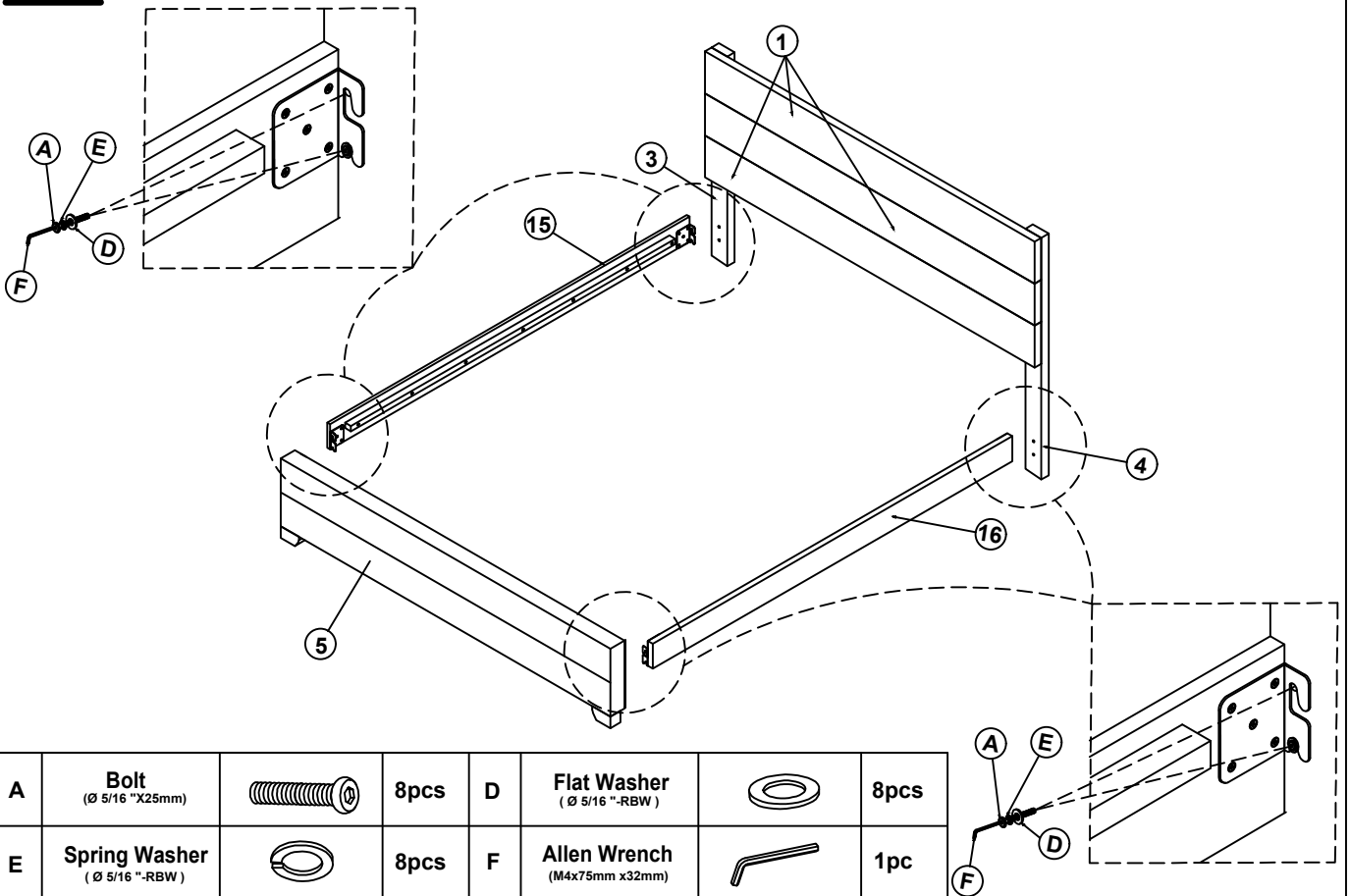

C	<b>Bolt</b> (Ø 5/16 "X55mm)		2pcs	D	<b>Flat Washer</b> (Ø 5/16 "RBW)		2pcs
E	<b>Spring Washer</b> (Ø 5/16 "RBW)		2pcs	F	<b>Allen Wrench</b> (M4x75mm x32mm)		1pc

# ASSEMBLY INSTRUCTIONS

## STEP 3



A	<b>Bolt</b> (Ø 5/16 "X25mm)		8pcs	D	<b>Flat Washer</b> (Ø 5/16 "-RBW)		8pcs
E	<b>Spring Washer</b> (Ø 5/16 "-RBW)		8pcs	F	<b>Allen Wrench</b> (M4x75mm x32mm)		1pc

## STEP 4

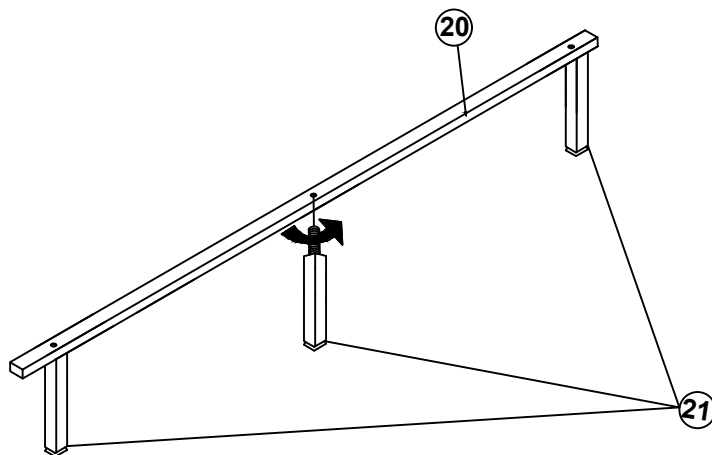

# ASSEMBLY INSTRUCTIONS

## STEP 5

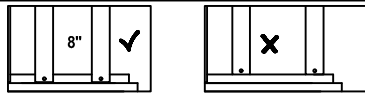
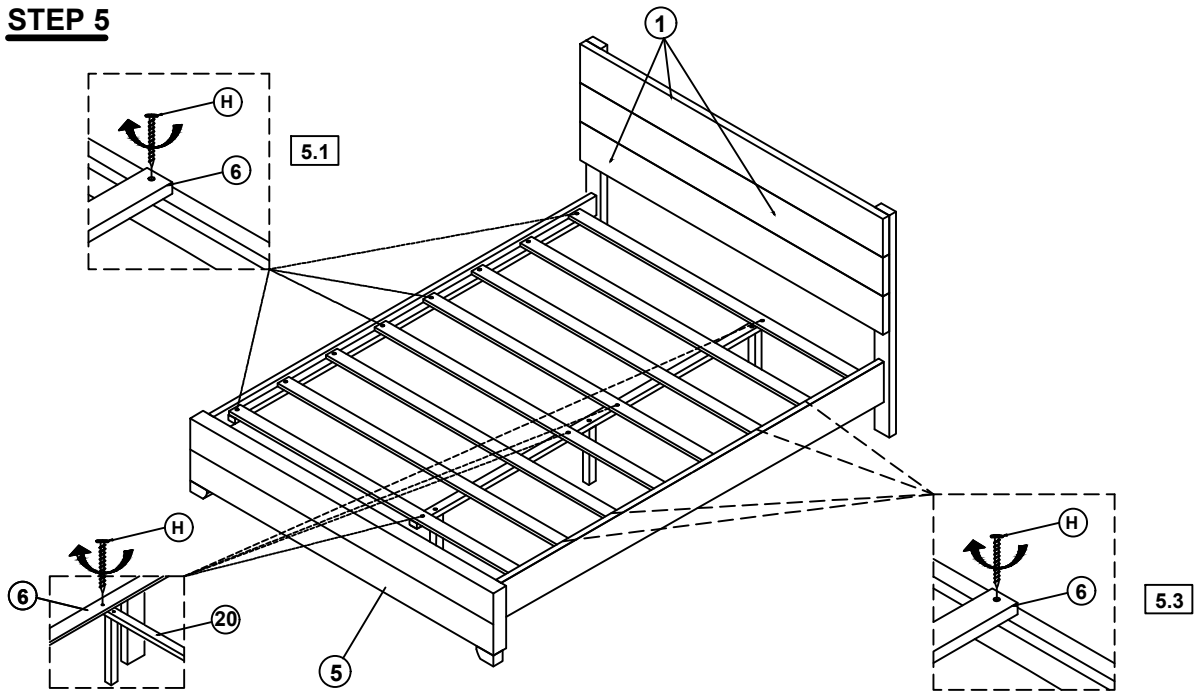

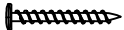

**NOTE:** Do not lock the screws of the trundle slats to the utermost edge the trundle slats, you need to leave a certain space at the edges, otherwise it will cause the board to break.

H	Flat Head Screw (m4x30mm-RBW)		20pcs
---	----------------------------------	---	-------

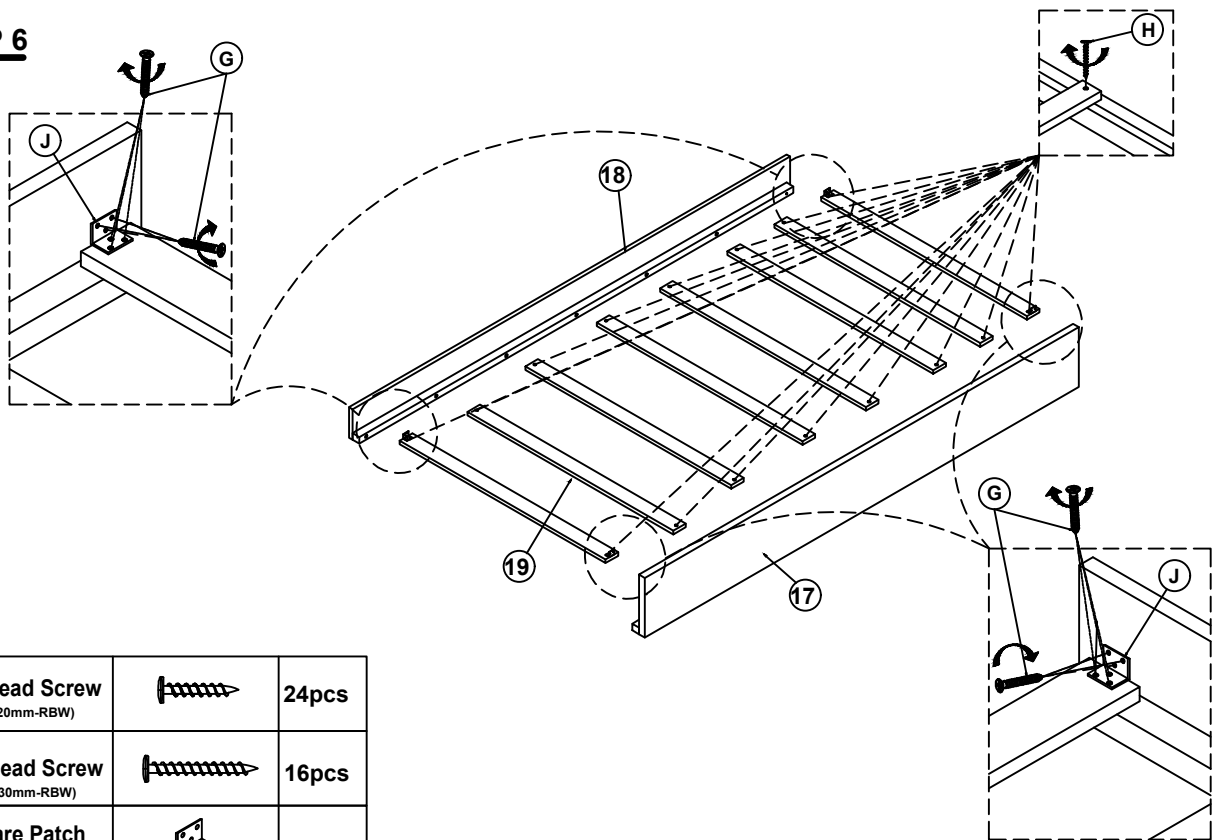
## STEP 6

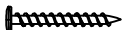



G	Flat Head Screw (m4x20mm-RBW)		24pcs
H	Flat Head Screw (m4x30mm-RBW)		16pcs
J	Square Patch (38mmx38mmx25mmx2mm)		4pcs

# ASSEMBLY INSTRUCTIONS

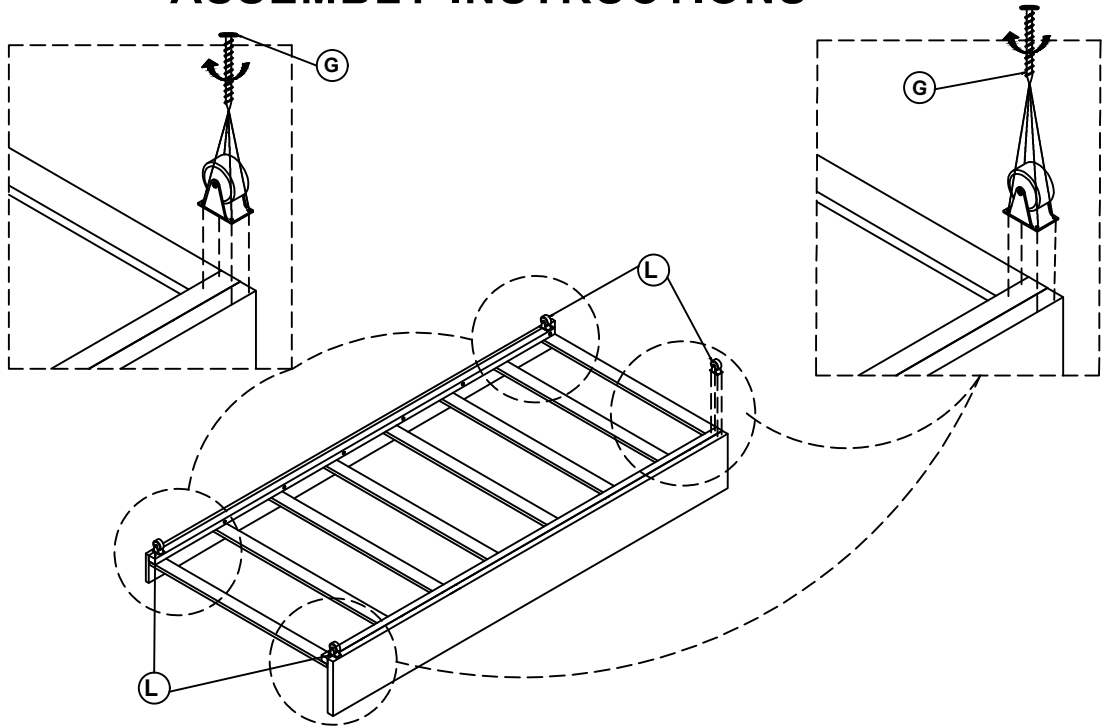
## STEP 7



G	Flat Head Screw (m4x20mm-RBW)		16pcs
L	Wheels (m41x25mmx50mm)		4pcs

## STEP 8

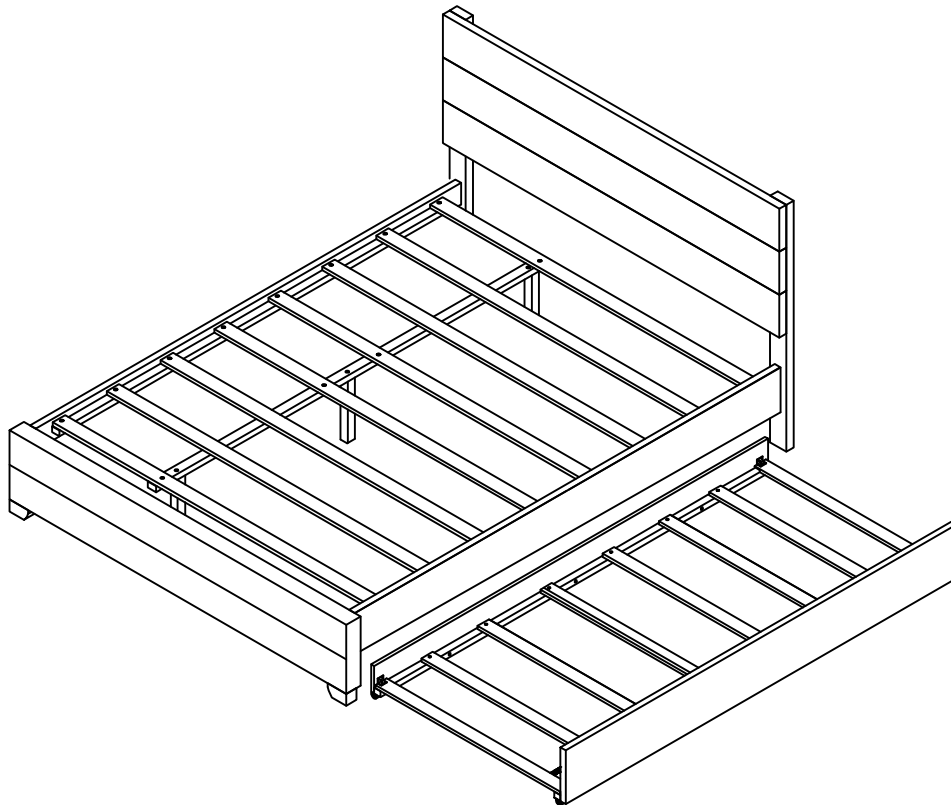

# ASSEMBLY INSTRUCTIONS

## STEP 9

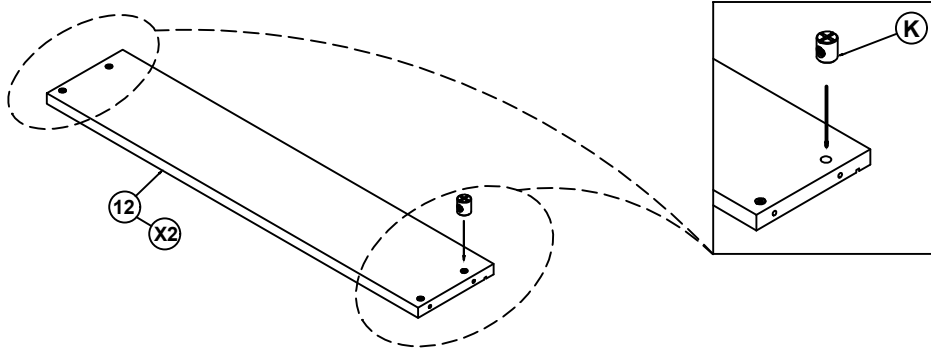

K	Plastic Button (Ø10x10mmx10mm)		8pcs
---	-----------------------------------	---	------

## STEP 10

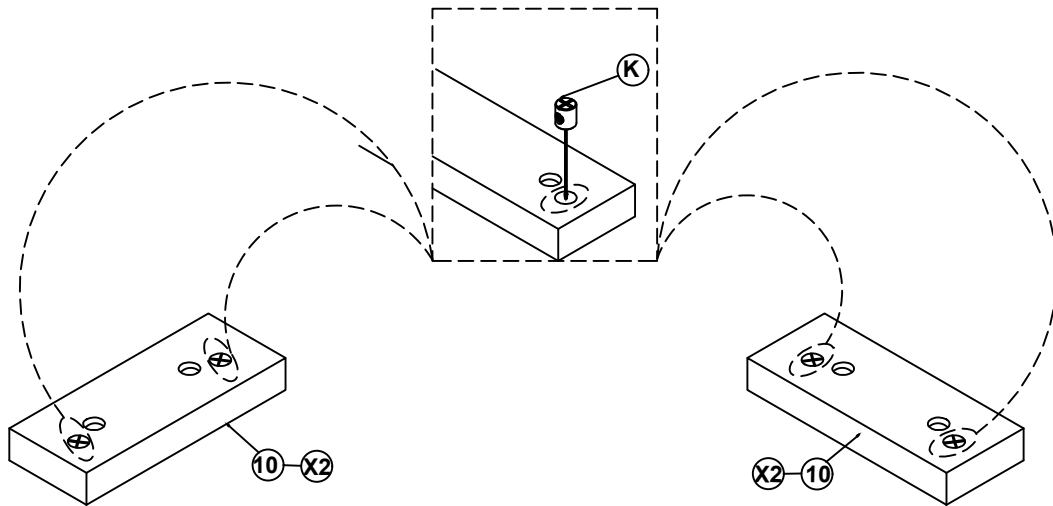

K	Plastic Button (Ø10x10mmx10mm)		8pcs
---	-----------------------------------	---	------

## STEP 11

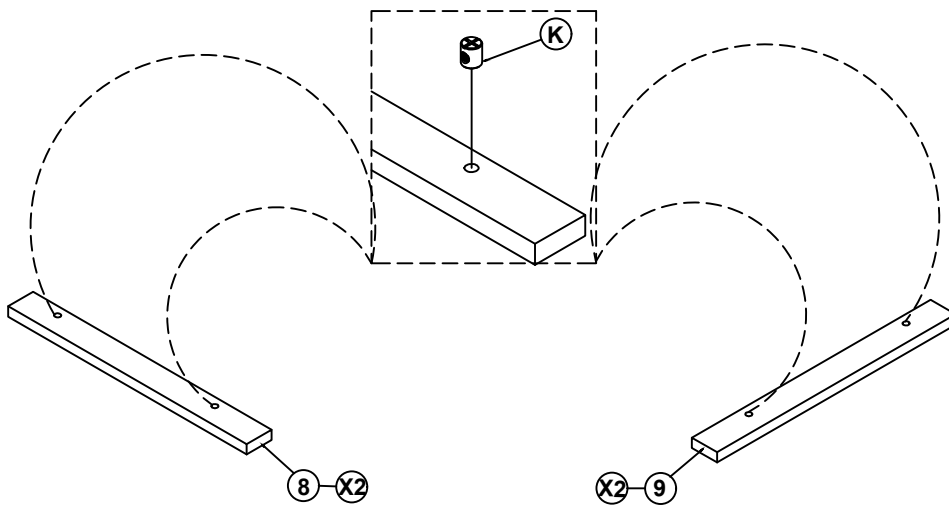

K	Plastic Button (Ø10x10mmx10mm)		8pcs
---	-----------------------------------	---	------

# ASSEMBLY INSTRUCTIONS

## STEP 12

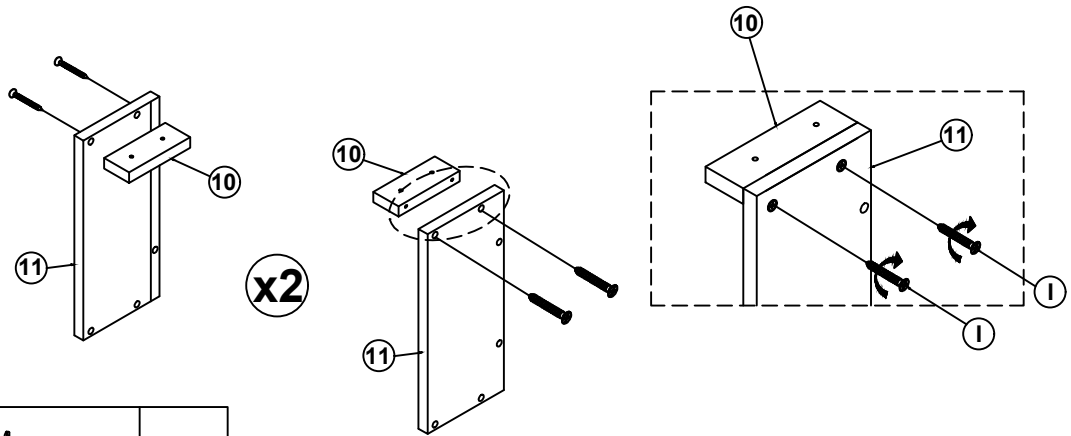

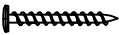
I	Flat Head Screw (m4x38mm-RBW)		8pcs
---	----------------------------------	---	------

## STEP 13

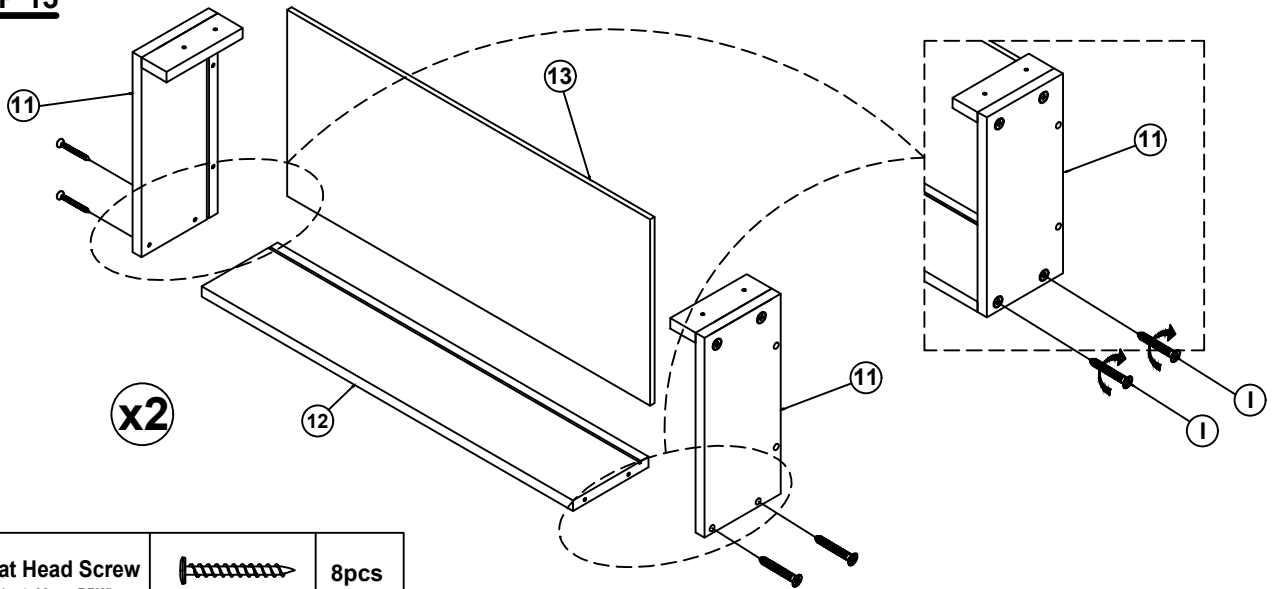

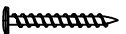
I	Flat Head Screw (m4x38mm-RBW)		8pcs
---	----------------------------------	---	------

## STEP 14

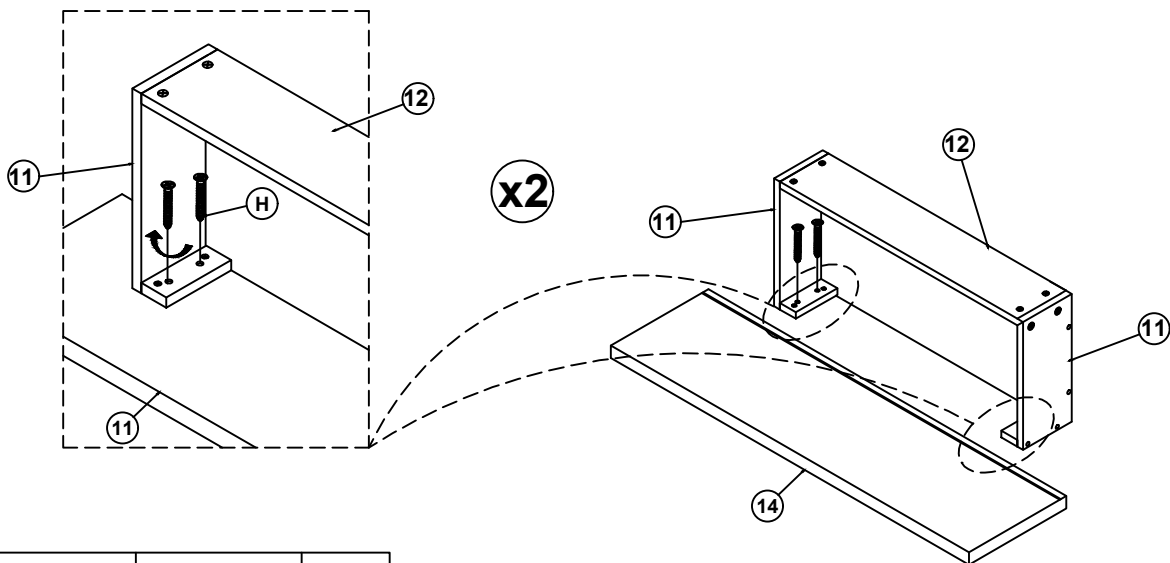

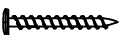
H	Flat Head Screw (m4x30mm-RBW)		8pcs
---	----------------------------------	---	------

# ASSEMBLY INSTRUCTIONS

## STEP 15

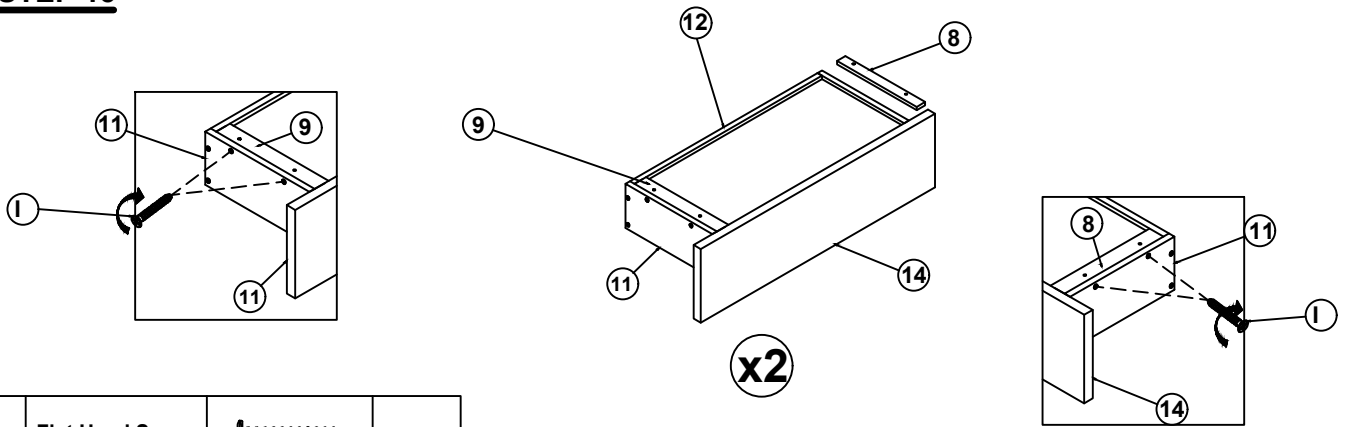

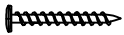
I	Flat Head Screw (m4x38mm-RBW)		8pcs
---	----------------------------------	---	------

## STEP 16

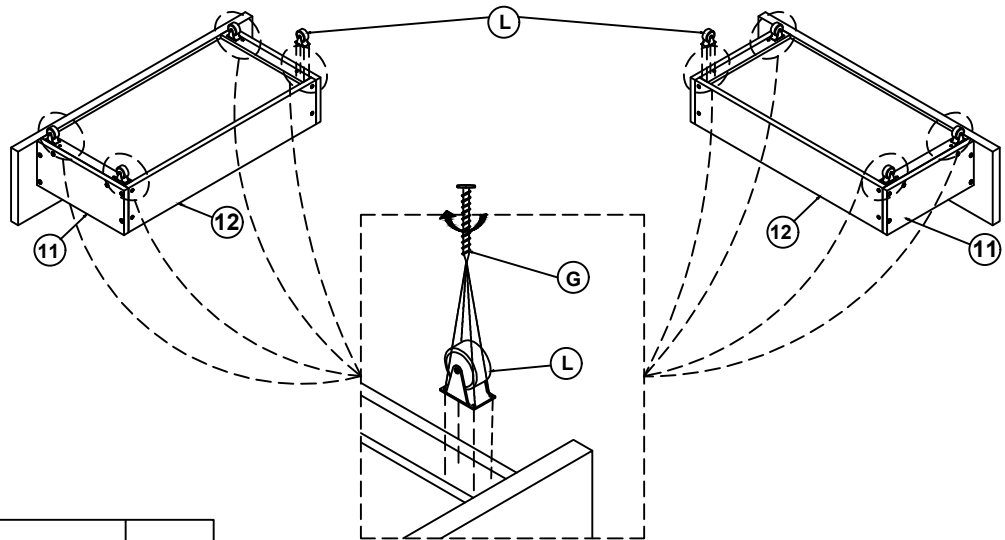

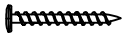
G	Flat Head Screw (m4x20mm-RBW)		32pcs
---	----------------------------------	---	-------

## STEP 17 COMPLETE

