

STEP 5

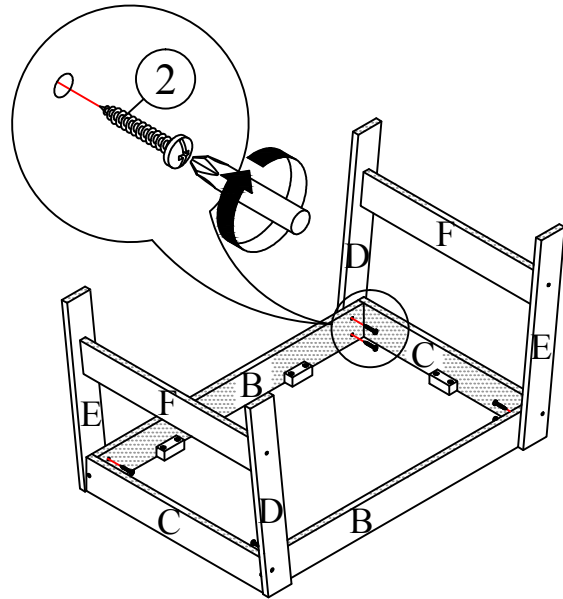

STEP 6

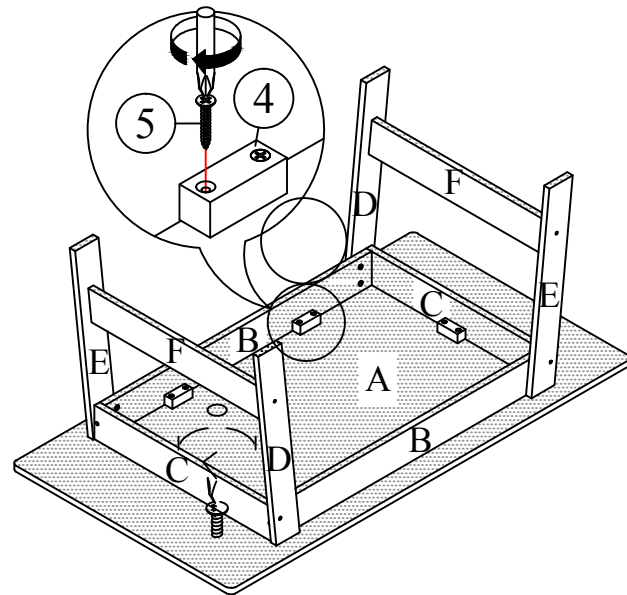

STEP 7

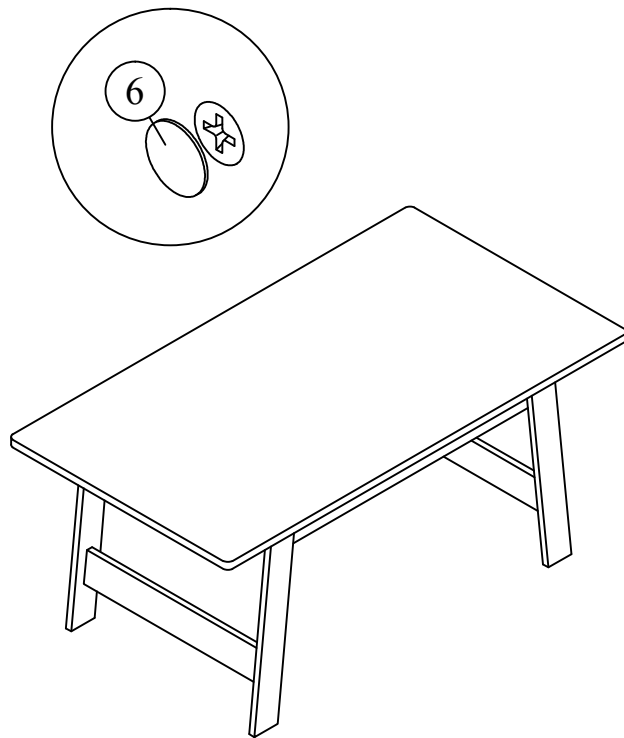

Recommended Maximum Weight

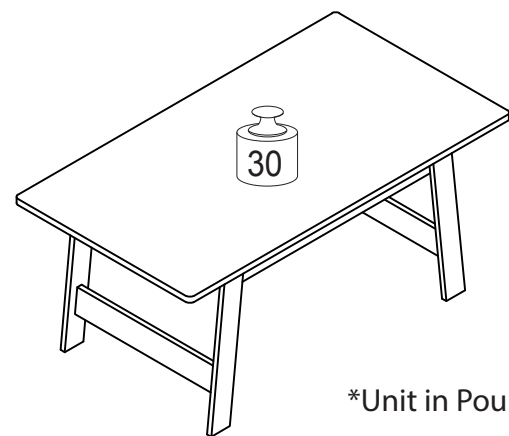

\*Unit in Pound(lbs)

**WARNING:**

>This unit has been designed to support the maximum loads shown. Exceeding these load limits could cause sagging, instability, product collapse, and/or serious injury.

>DO NOT allow children to climb on unit.

# Assembly Instruction

00:20

Approx. 20 minutes





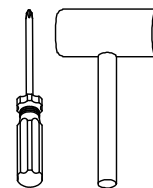

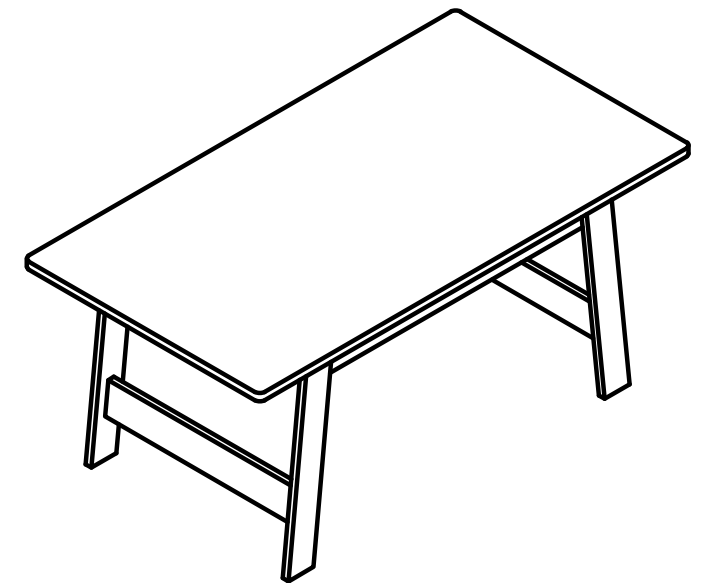

Recomm. 1 Person



Tool Required



NO	HARDWARE LIST	QTY
1	LONG SCREW 	12pcs
2	PH TAPPING SCREW 	8pcs
3	DOWEL 	8pcs
4	BRACKET 	6pcs
5	MIDDLE SCREW 	12pcs
6	STICKER 	8pcs

NO	PARTS LIST	QTY
A	TOP PANEL	1pc
B	FRONT & BACK SUPPORT PANEL	2pcs
C	SIDE SUPPORT PANEL	2pcs
D	LEFT LEG PANEL	2pcs
E	RIGHT LEG PANEL	2pcs
F	LEG SUPPORT PANEL	2pcs

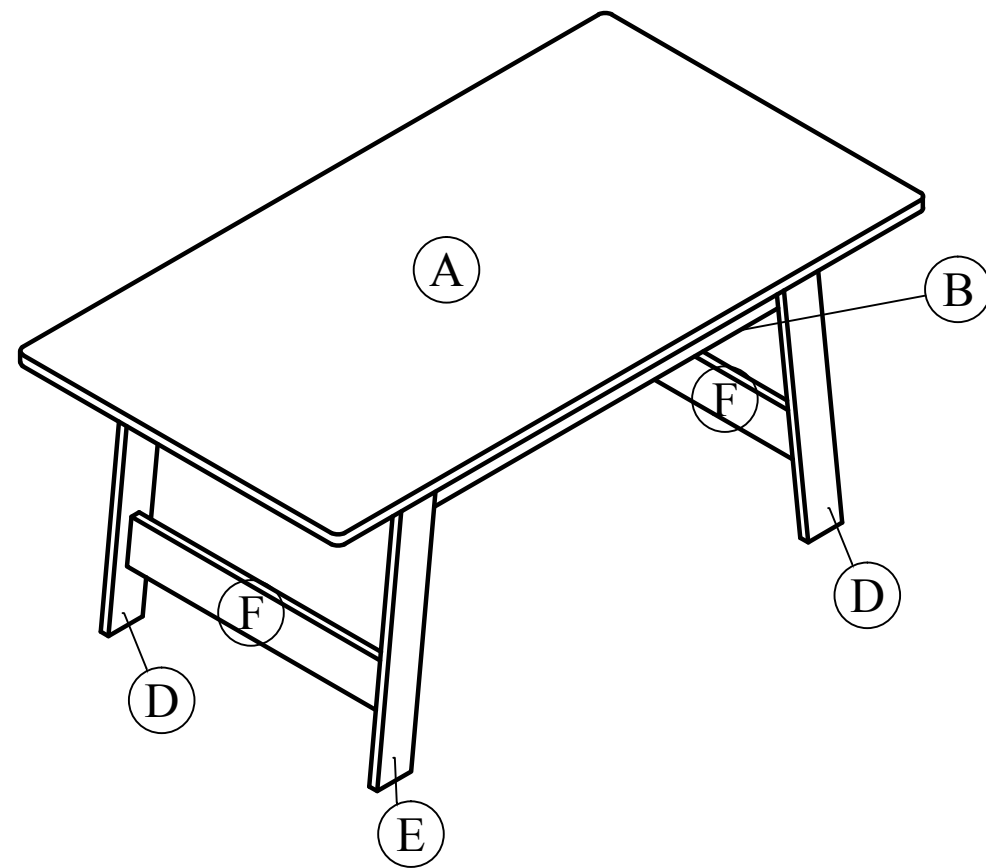

**USEFUL HINTS BEFORE YOU START:**

1. Read each step carefully before starting.
2. It is important that each step is performed in correct order to avoid difficulties.
3. Identify, sort and count the parts before assembly.
4. Assemble your furniture on packaging cardboard to prevent scratch or damage.
5. Clean the product with mild cleanser using soft dampened cloth. Do not use harsh or abrasive cleanser.
6. Using incompatible hardware might cause damage to product.

**STEP 1**

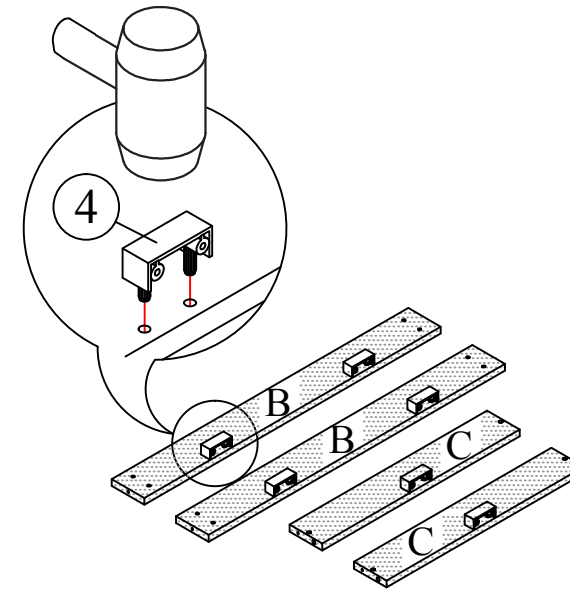

**STEP 2**

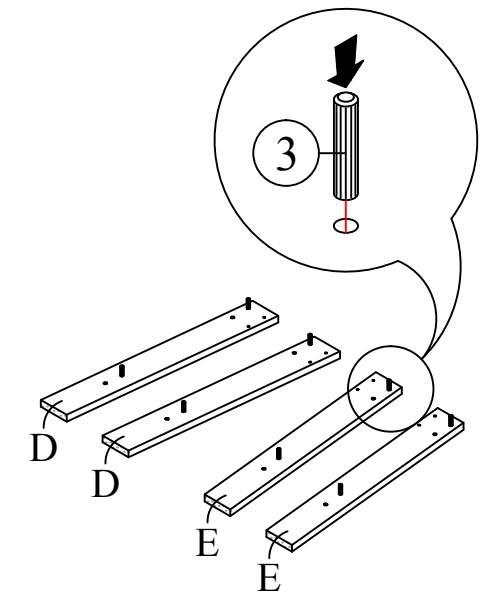

**STEP 3**

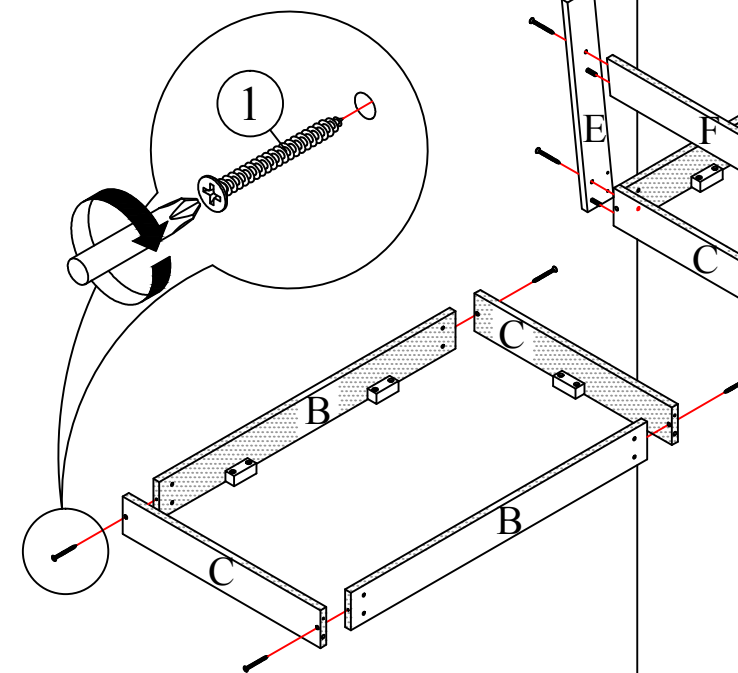

**STEP 4**

