

BENCH

ASSEMBLY INSTRUCTION



Assembly Instruction

ASSEMBLY TIPS:

- 1.Remove hardware from box and sort by size.
- 2.Please check to see that all hardware and parts are present prior to start of assembly.
- 3.please follow attached instructions in the same sequence as numbered to assurefast & easy assembly.

⚠ Warning!

- 1.Don't attempt to repair or modify parts that are broken or defective.Please contsct the store immediately.
- 2.This product is for home use only and not intended for commercial establishment.

PARTS IDENTIFICATION:

(A) CUSHION

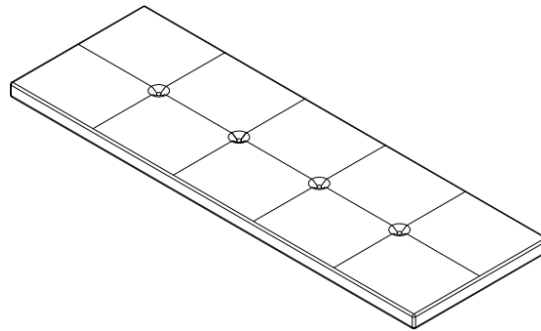

1PC

(B) CUSHION
FRAME

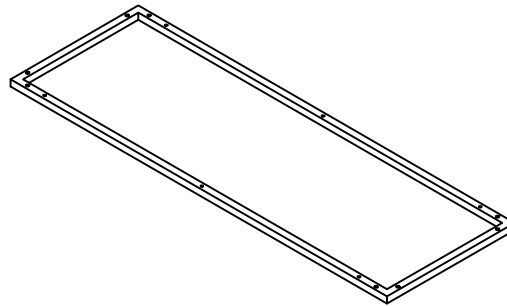

1PC

(C) CROSSBAR

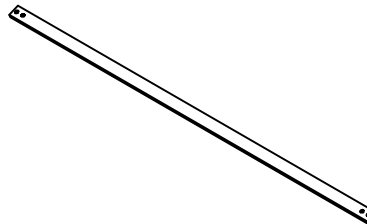

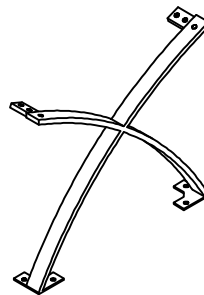

2PCS

(D) SIDE

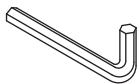

2PCS

Z	HARDWARE PACKAGE:		
NO	DESCRIPTION	FIGURE	QTY
1	SCREW Φ 4*40mm		6pcs
2	ALLEN BOLT Φ 1/4*14mm		16pcs
3	LEVERLER Φ 1/4*10mm		4pcs
4	ALLEN WRENCH Φ 1/4*66mm		1pc

You will need two people for this installation. And will take about thirty-five minutes.

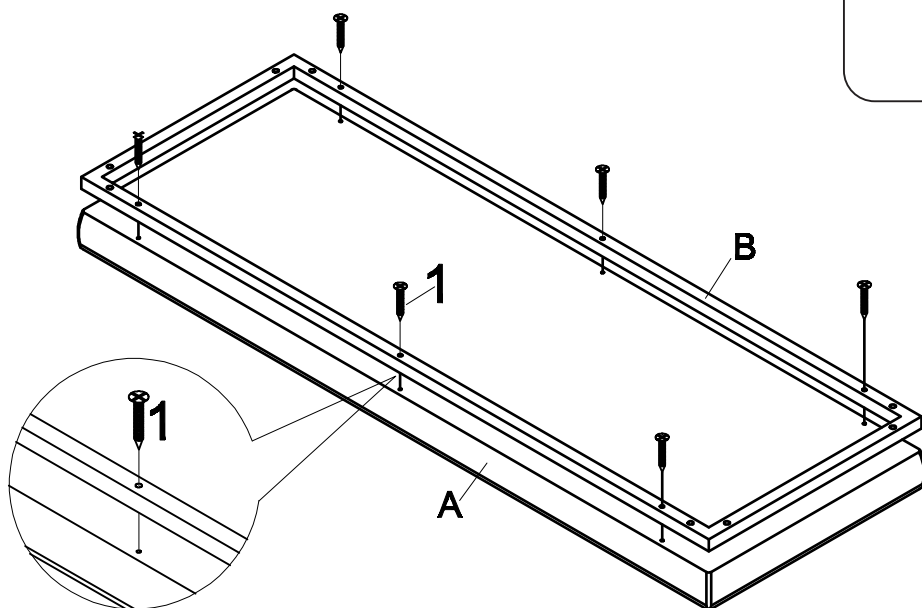
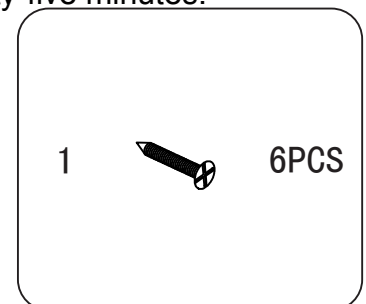

Step 1: Place the cushion (A) upside down on a soft surface.

Then align and attach the cushion frame (B) to the cushion (A) using the screws (1) tighten with the screw driver (NOT INCLUDED)



ASSEMBLY INSTRUCTION

STEP 2: Align and attach the crossbar (C) to the side (D) using allen bolt (2) tighten with allen wrench. Then screw four levelers into bottom of the bases.

- | | | |
|---|---|------|
| 2 |  | 8PCS |
| 3 |  | 4PCS |

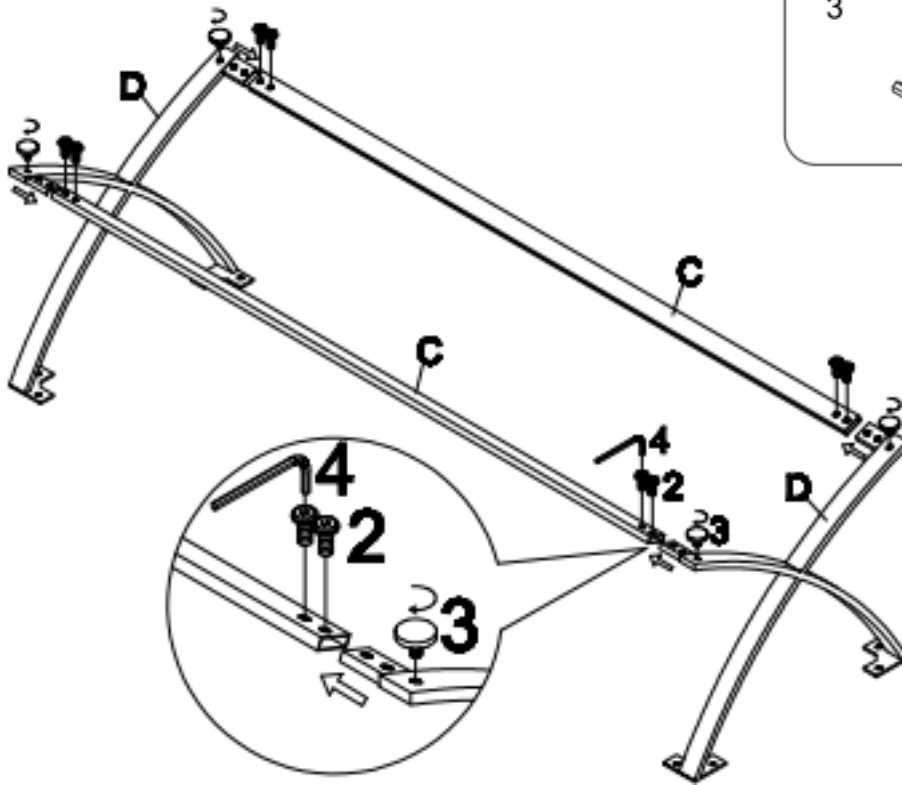

STEP 3: Align and holes of the base to them of cushion support and tighten them up with bolt and allen wrench.

- | | | |
|---|---|------|
| 2 |  | 8PCS |
|---|---|------|

