

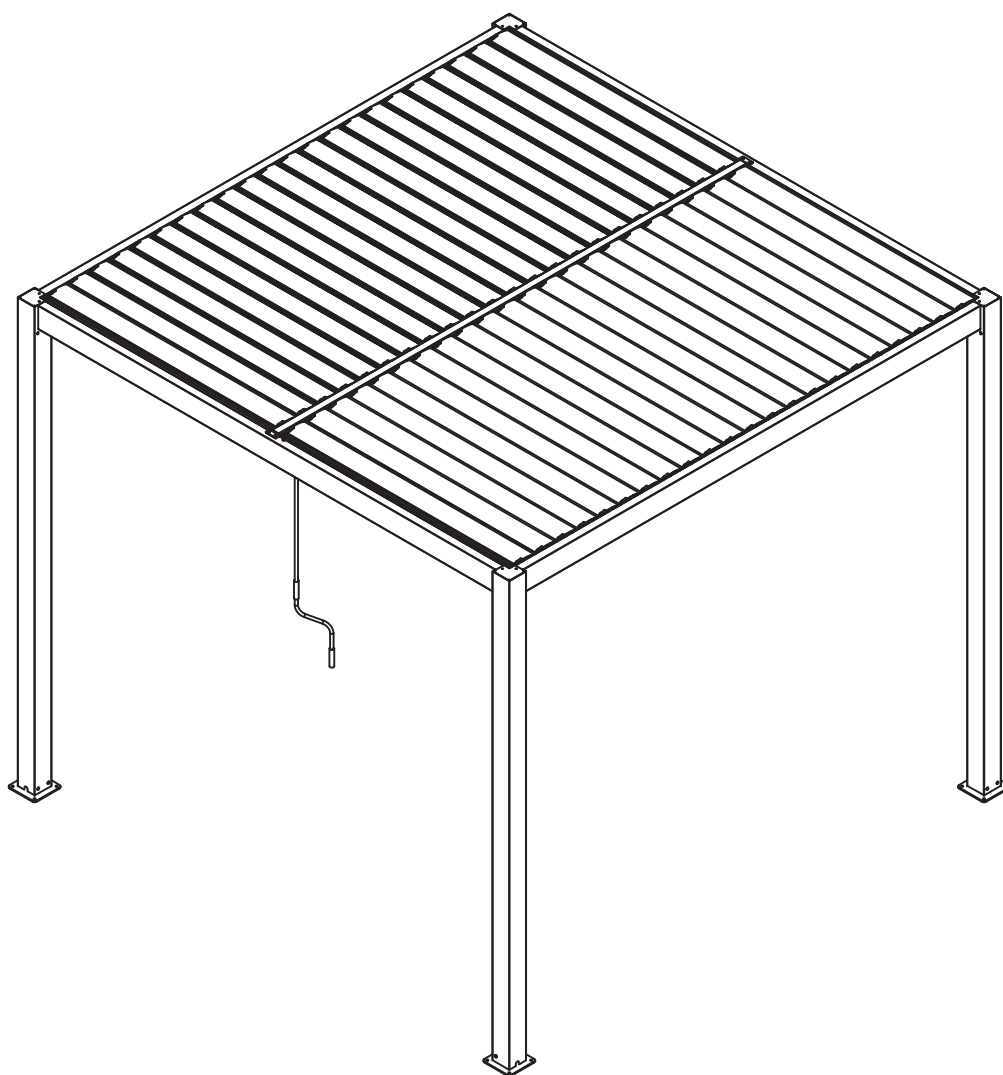

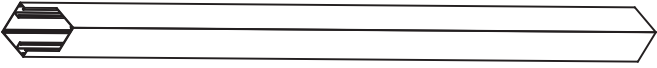







Louvered Pergola Instruction Manual



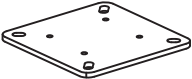
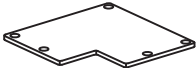
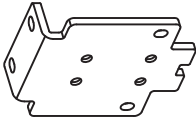





10'x 13' (3x4m)

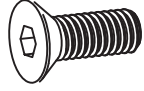
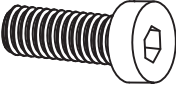
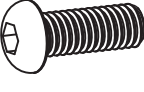

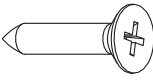
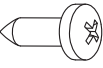
THE PARTS LIST

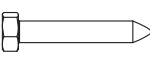
Article No.	Part Name	Part Sketch	Qty
A	Column		4
B1	Left Beam		1
B2	Right Beam		1
C	Front and Rear Beam		2
D	Middle Beam		1
E	Louver		60
F	Column Bottom Plate		4
G	Column Top Plate		4
H	Middle Beam Connector		2
I	Thick Mending Plate 1		8
J	Thick Mending Plate 2		8
L	Ring for the gearbox		2
M	Handle Crank		1

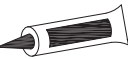
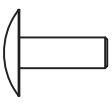
THE PARTS LIST

Article No.	Part Name	Part Sketch	Qty
K1	Flat Head Hex Socket Cap Screw	 M6×16	8
K2	Hex Socket Cap Screw	 M8×25	16
K3	Button Head Hex Socket Cap Screw	 M6×16	16
K4	Gasket	 Φ6	8
K5	Phillips Flat Head Self-drilling Screw	 ST5.5×32	16
K6	Phillips Pan Head Self-drilling Screw	 ST5.5×16	12
K7	Phillips Pan Head Screw + Hex Nut	 M4  M4×20	2
K8	Hex Head Wood Screw + Ribbed Plastic Anchor	 M8×75  Φ8  Φ10×50	16
K9	Glue		1
N	Plastic Plug for the louver hole		120
J	Plastic Plug for Beam Holes		16
P	Bolt Cover		16

Kinder Reminder

General Guidelines

- Please keep this manual for future use after you install the pergola.
- Please read the following instruction carefully before assembly.
- This manual may not include every details and considerable steps.
- Please contact us when you need further information or any help.

Kind Notes

- Please do not allow snow to accumulate on the louver roof. If moderate or heavy snow is expected to coming, do open the louvers, also does it in the conditions of high winds or other extreme weather conditions.
- Please open the louvers and raise or remove any shade screen accessories that have been installed to avoid potential damage to the pergola when bad weather comes.

What you may need?



Safety hat



Glove

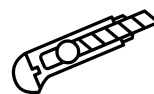

Knife



Tapeline



Wooden Hammer



Level



Marker

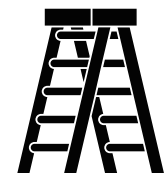

Ladder x 2

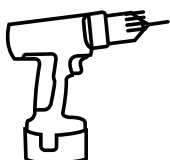

Electric screw driver

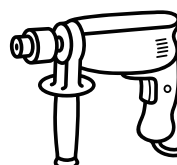

Electric Rotary Hammer

Overall Size Display

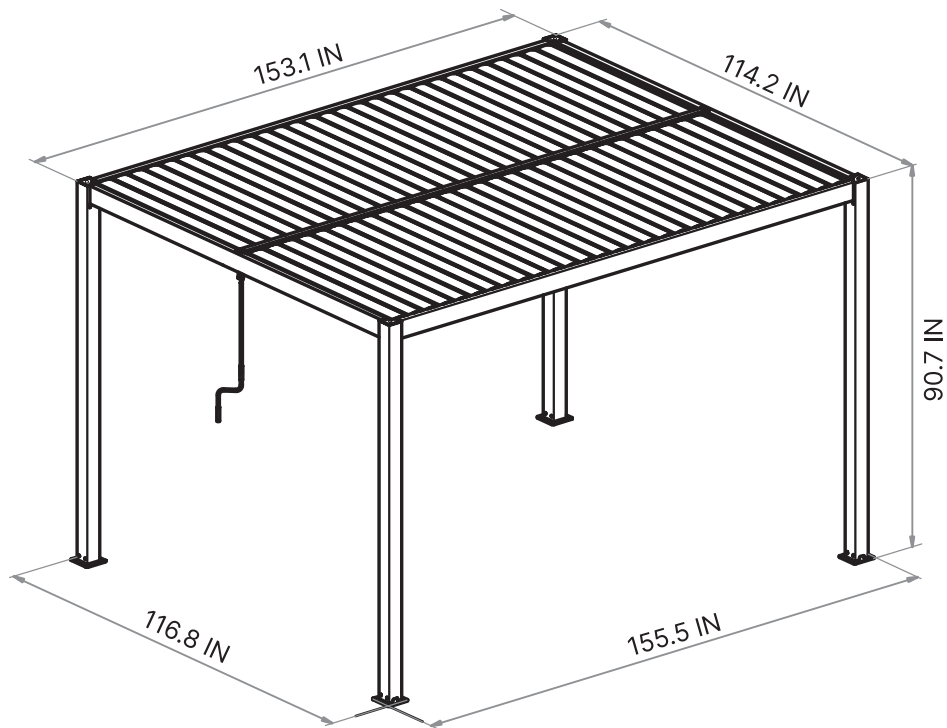
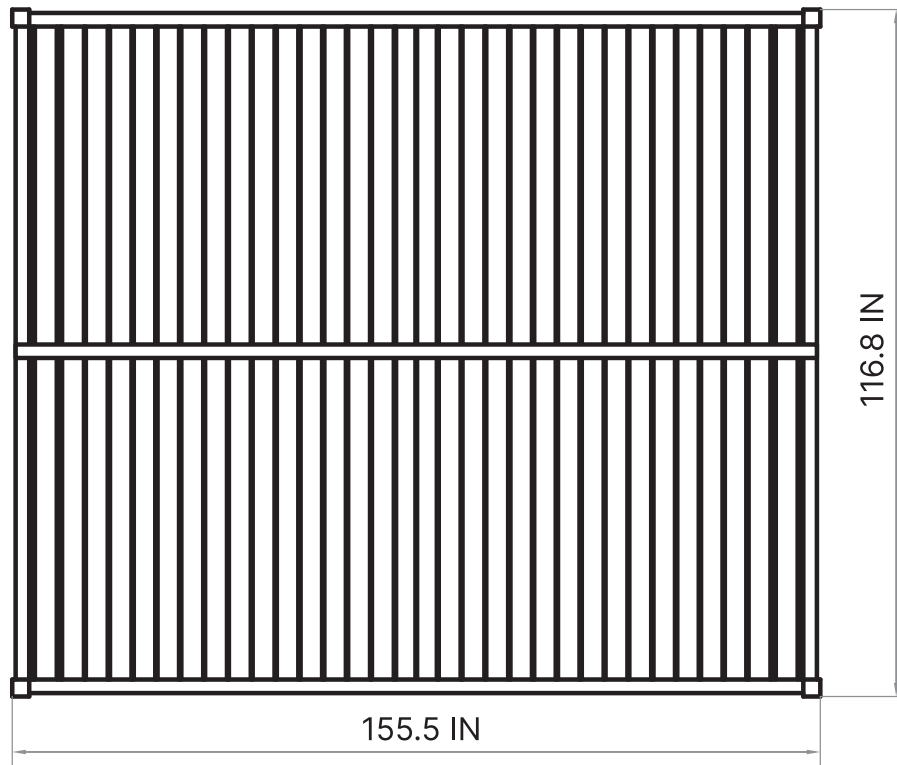

Step-by-step Instructions for Installation

1. Insert the drainage fitting Q into the U-shape groove of the column bottom, then install the column bottom plate F on column A and tighten up with screws K5.

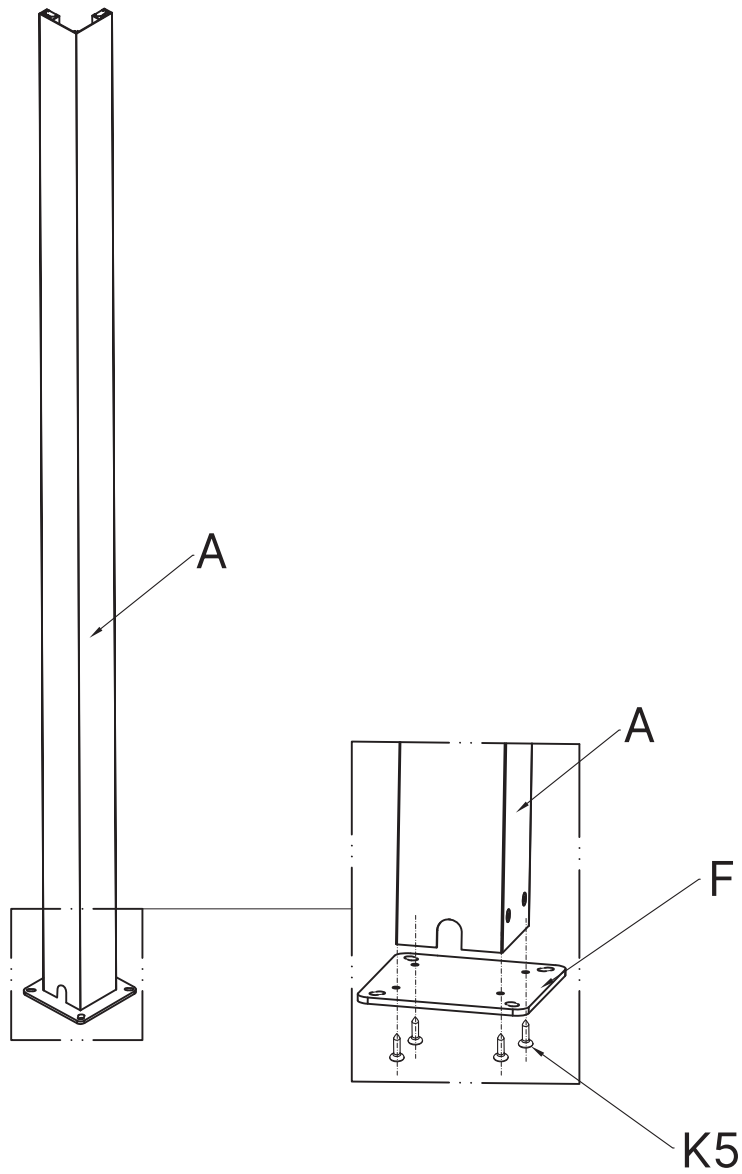

K5

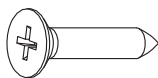

16 pcs

F



4 pcs

2. Install the middle beam connector H on one end of the middle beam D, and tighten up with screw K1; Repeat this operation for another end of D.

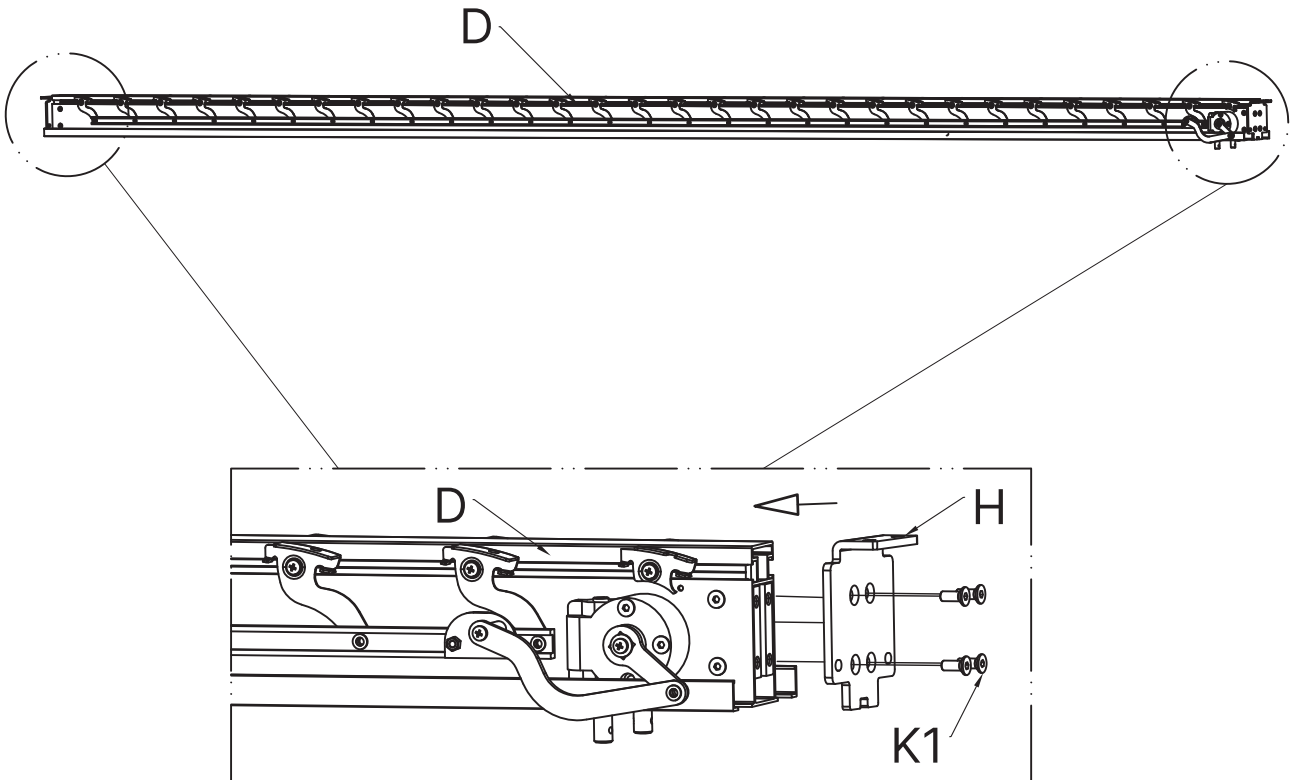

K1



8 pcs

H



2 pcs

3. Install the two rings L on the gear box, and tighten up with screw K7.

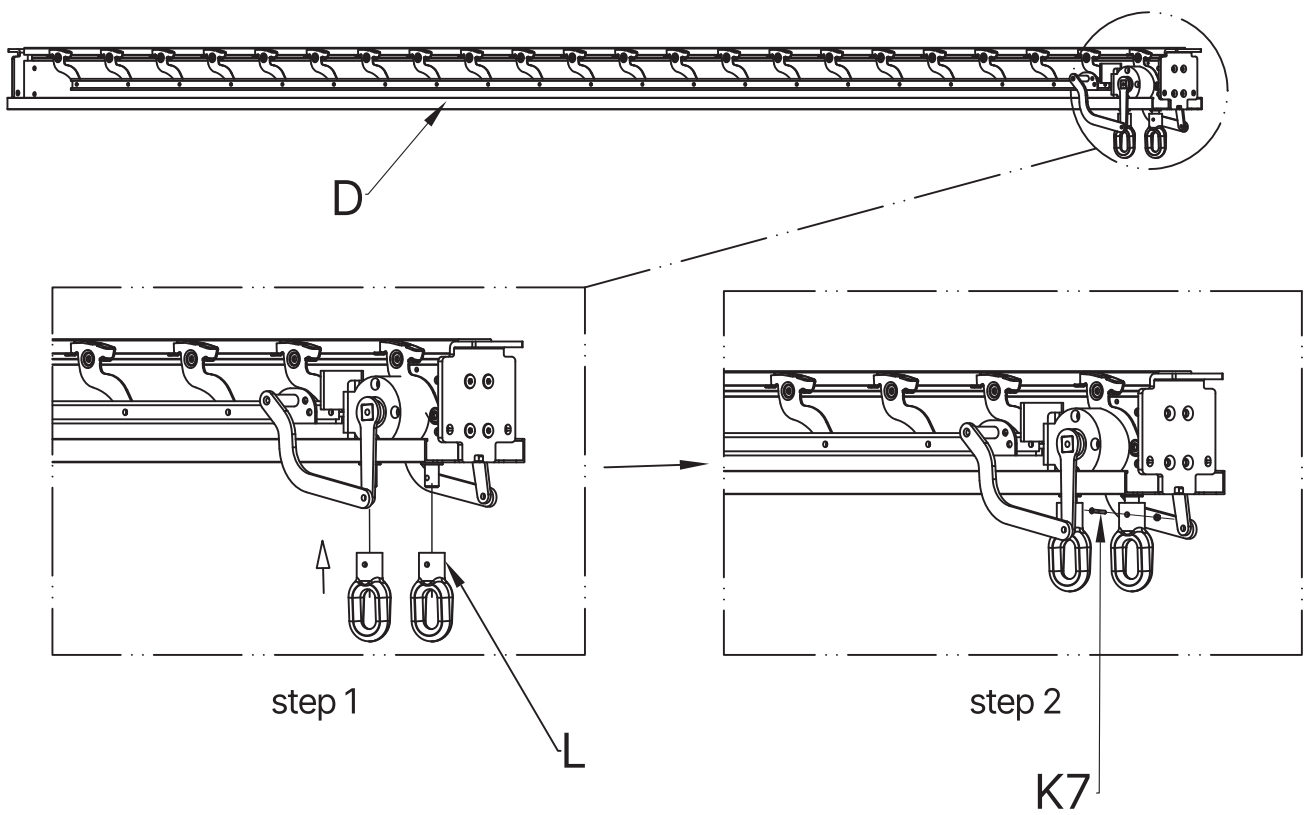

L

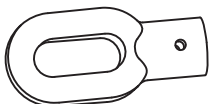

2 pcs

K7



M4





M4x20

2 set

4. The I [the thick mending plate 1] shall be outside the beam end meanwhile the J [the thick mending plate 2] shall be inside the beam end; Align all holes, and tighten them with screws K2 by about 75% force so that I [plate 1] and J [plate 2] are movable;

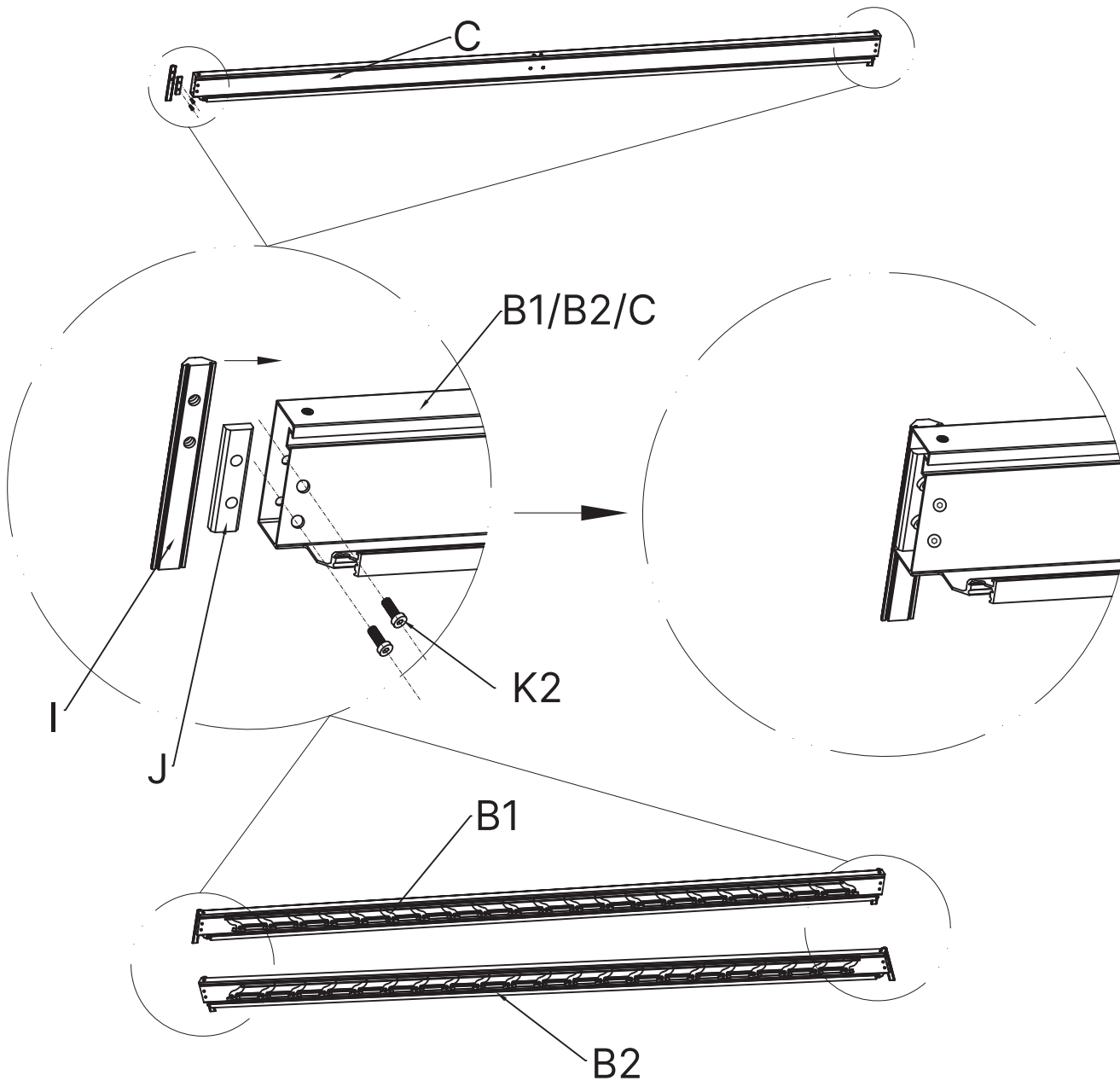
Repeat this operation for all other beam [B1, B2 and C] ends.



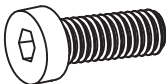

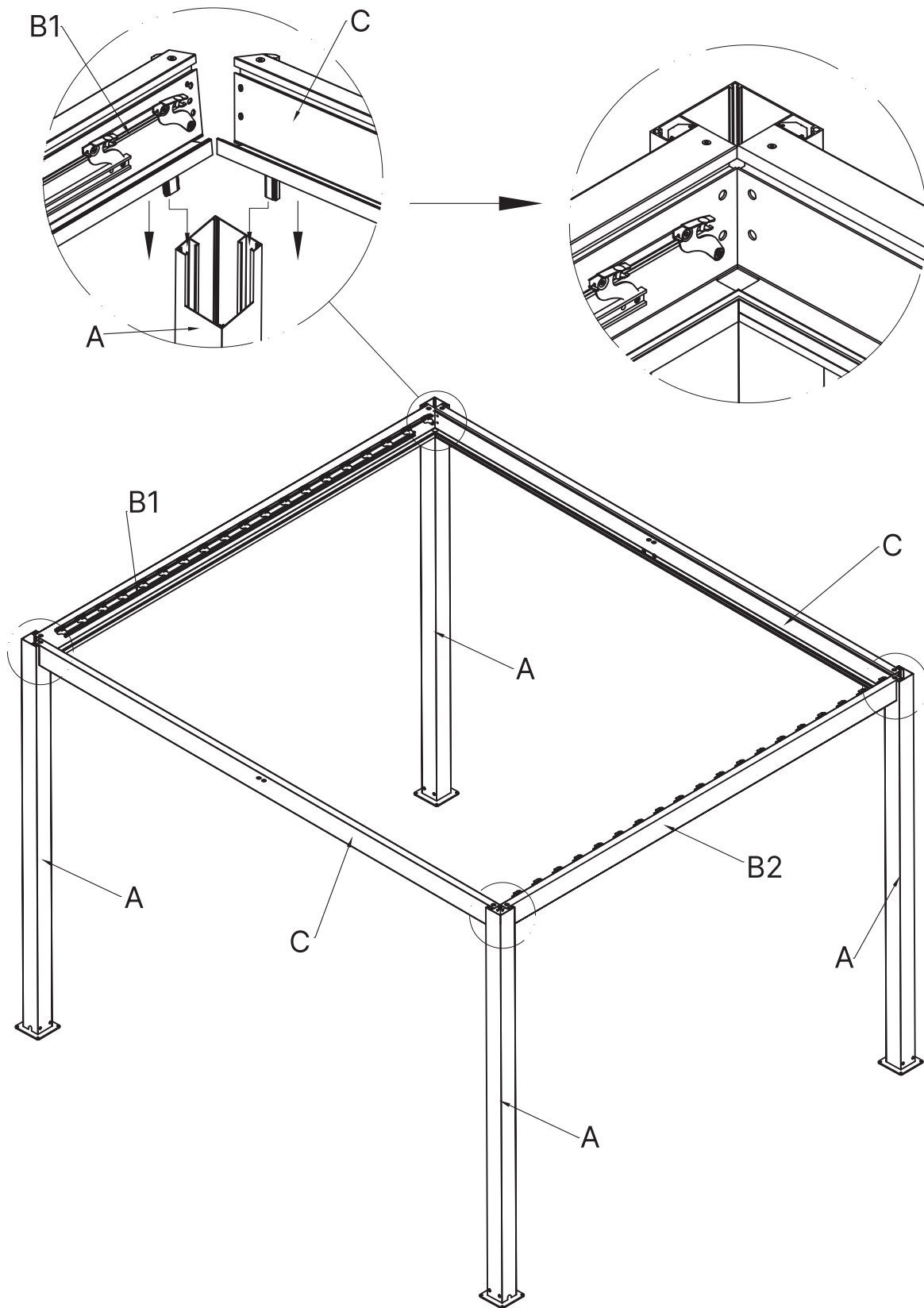

I		8 pcs	J		8 pcs
K2		16 pcs			

5. Insert I [plate 1] and J [plate 2] into the slots of column A respectively.

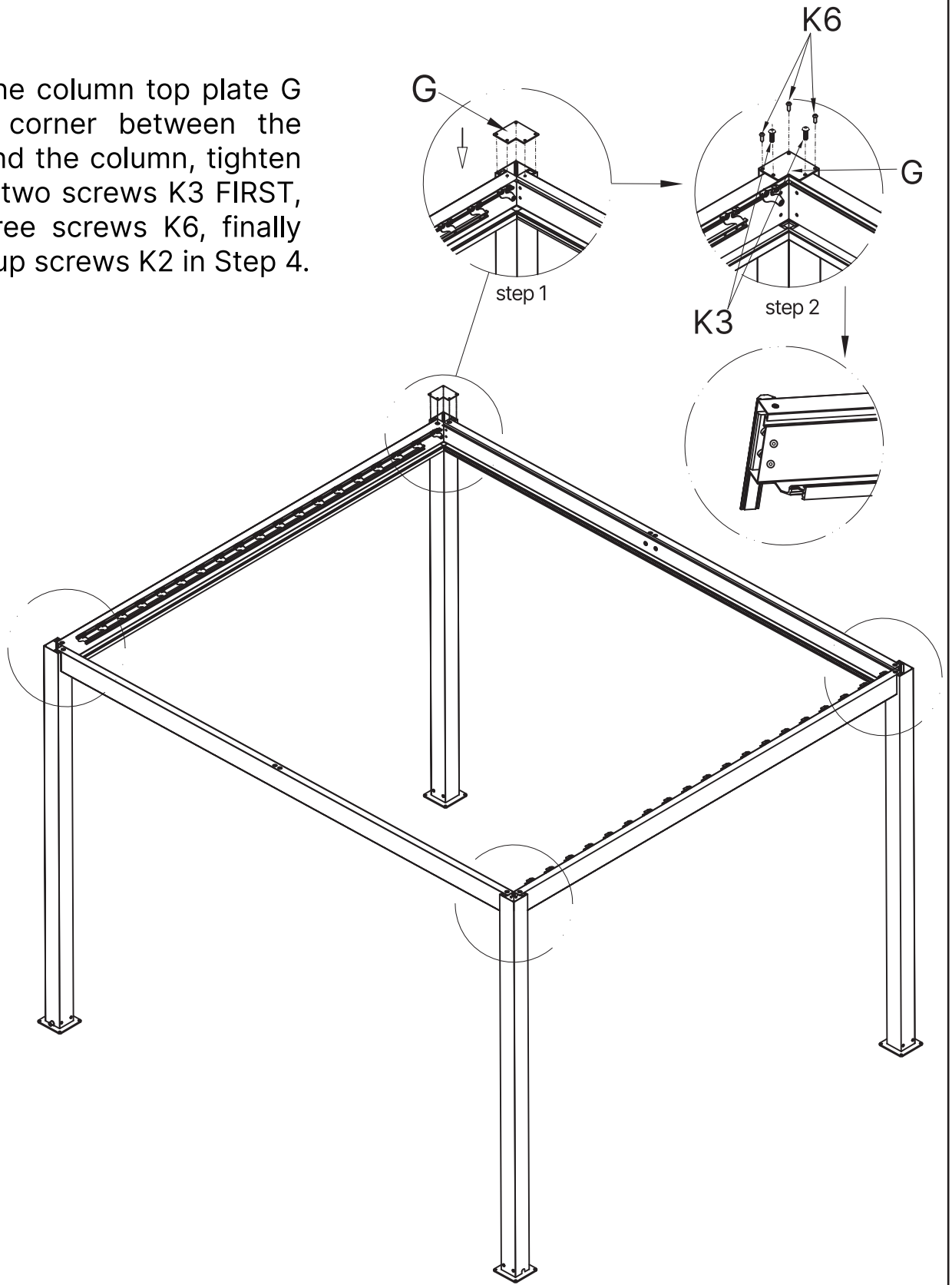

6. Put the column top plate G on the corner between the beam and the column, tighten up with two screws K3 FIRST, then three screws K6, finally tighten up screws K2 in Step 4.

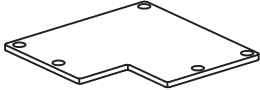

K6		12 pcs	G		4 pcs
K3		8 pcs			

7. To move the frame structure to the installation place, ensure the four columns are vertical to the ground, and confirm the distances between column top and column bottom are the same.

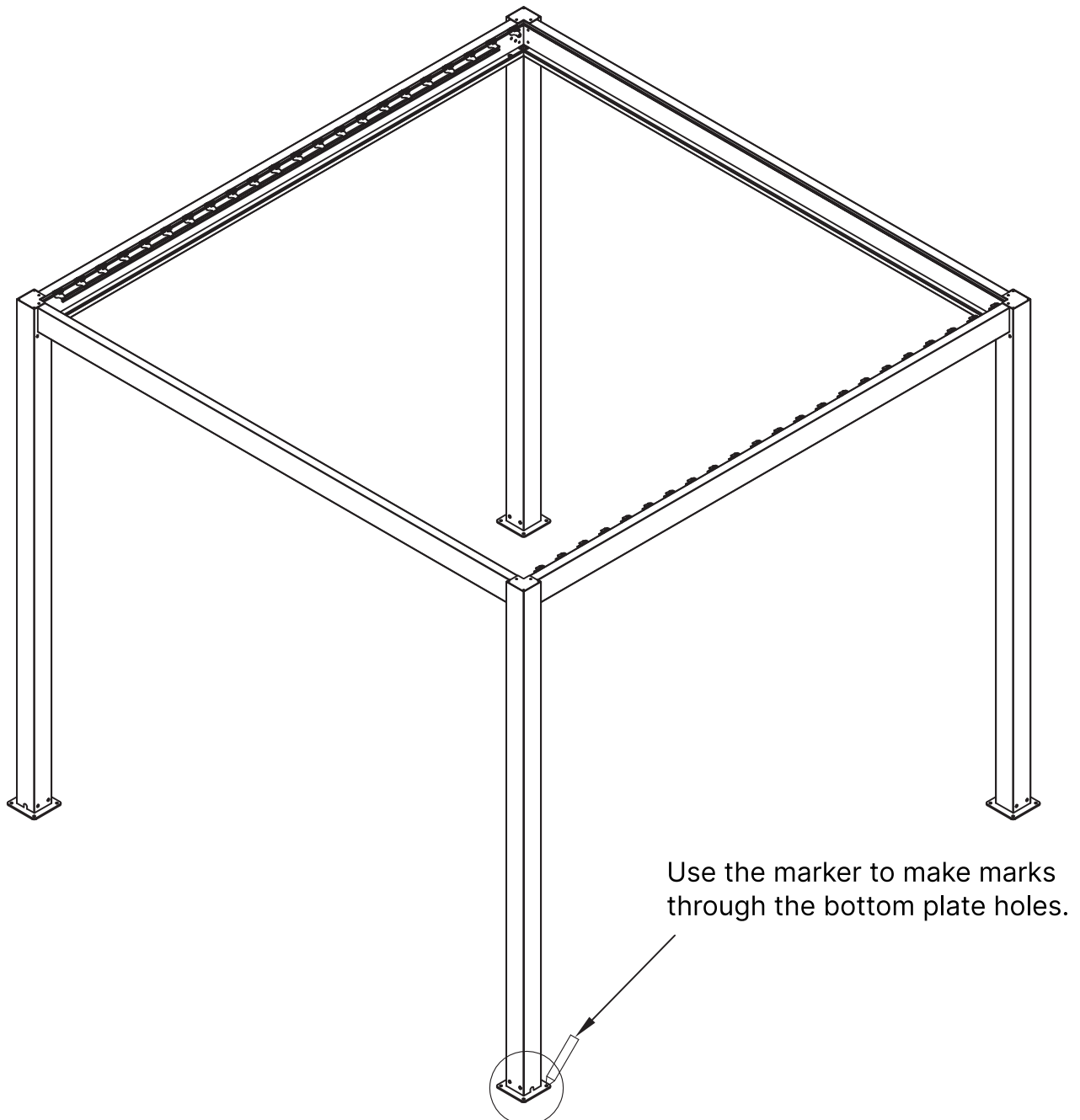

Extra tool needed: a marker(Please prepare it before the assembly)

8. To move the frame structure away from the marks, and drill holes by the rotary hammer drill.

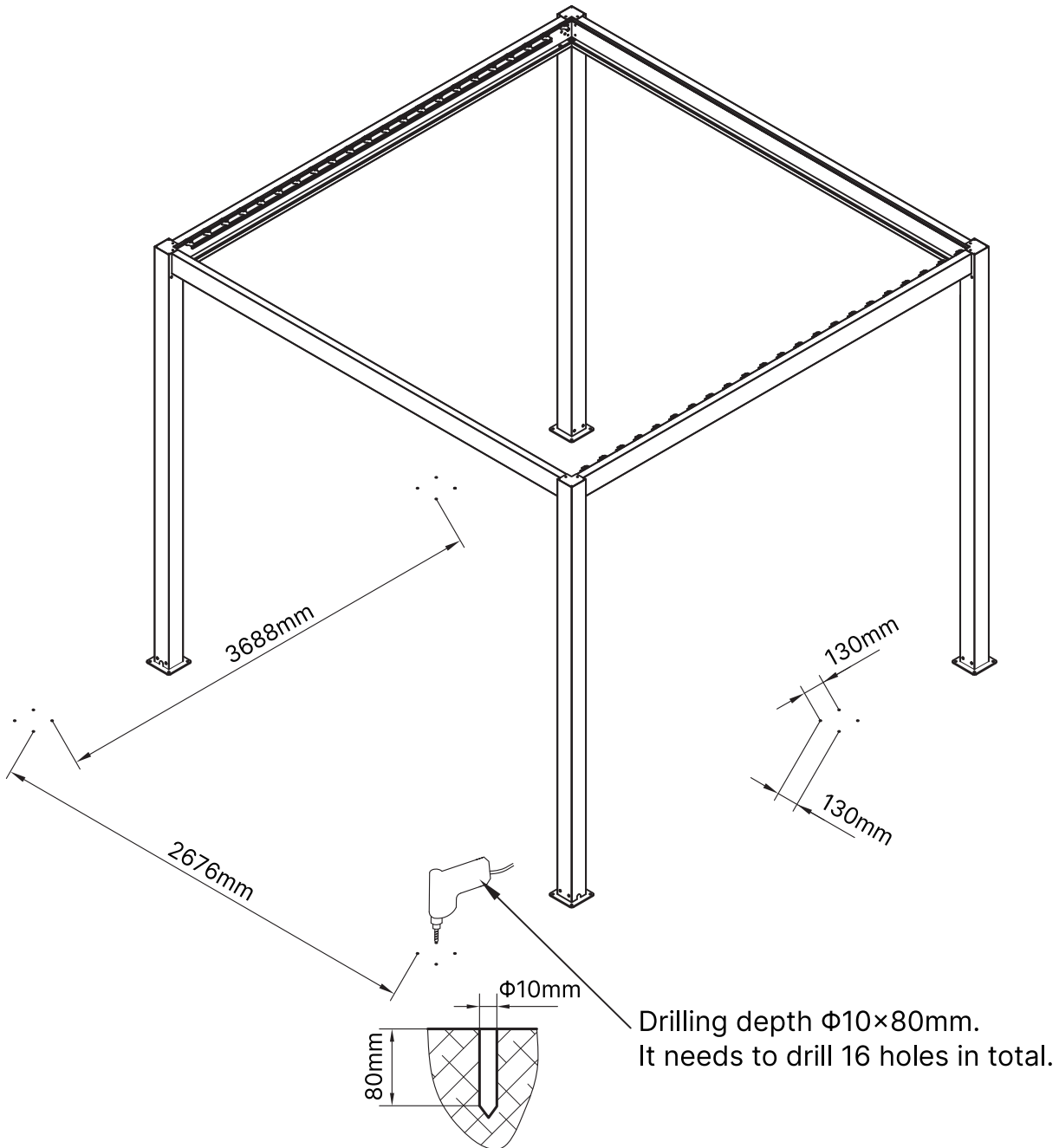

Tool: one electric rotary hammer with a $\Phi 10$ drill bit (Please prepare it before assembly)

9. Put the ribbed plastic anchors into the bottom holes of the column, move the structure back to the correct position, align the four bottom plates with the holes on the ground; then put the gasket onto the hex head wood screw, and tighten all screws up on the ground. Lastly, cover the bolt with the bolt cover P.

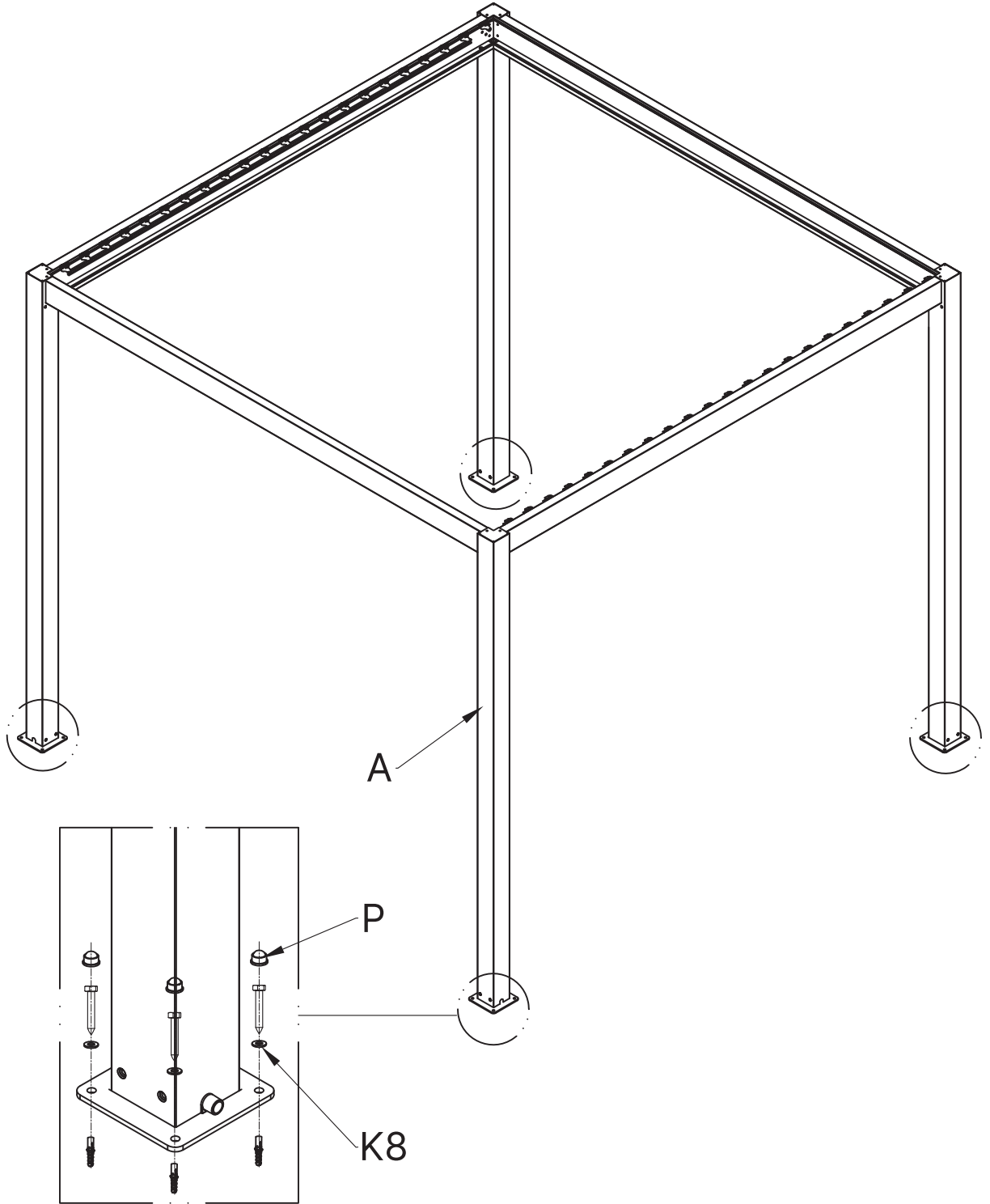

K8

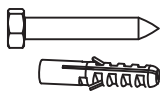

16 pcs

P



16 pcs

10. Insert the hole plug O on all beam interior ends; glue all seams on the drainage periphery as well as the connecting places of four column corners.

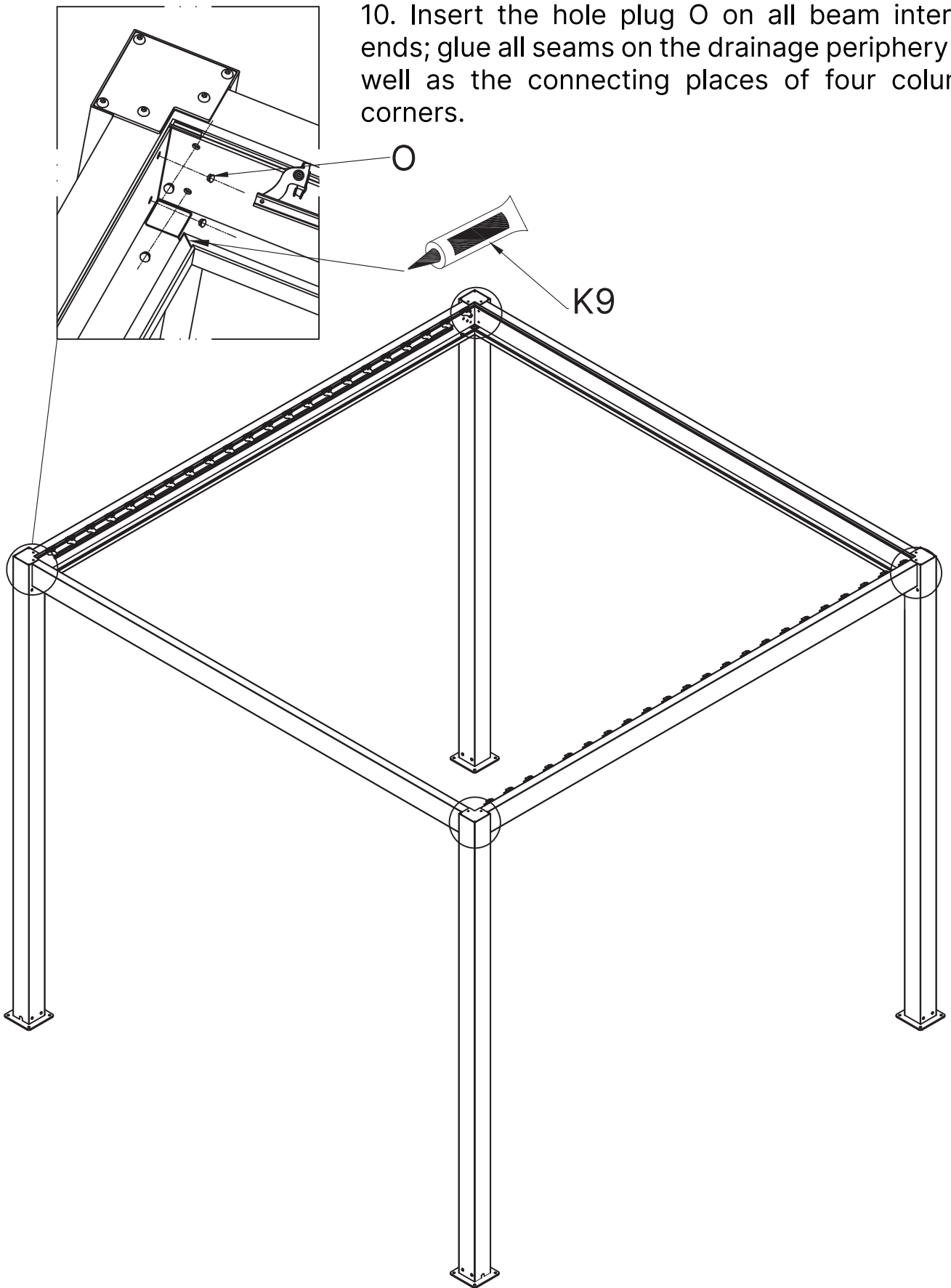

K9

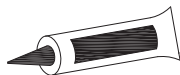

1 pc

O



16 pcs

11. To put the middle beam D on the front and rear beams C, then tighten the connector by screws K3 with gaskets K4 by 30% force [Do Not tighten up at this step].

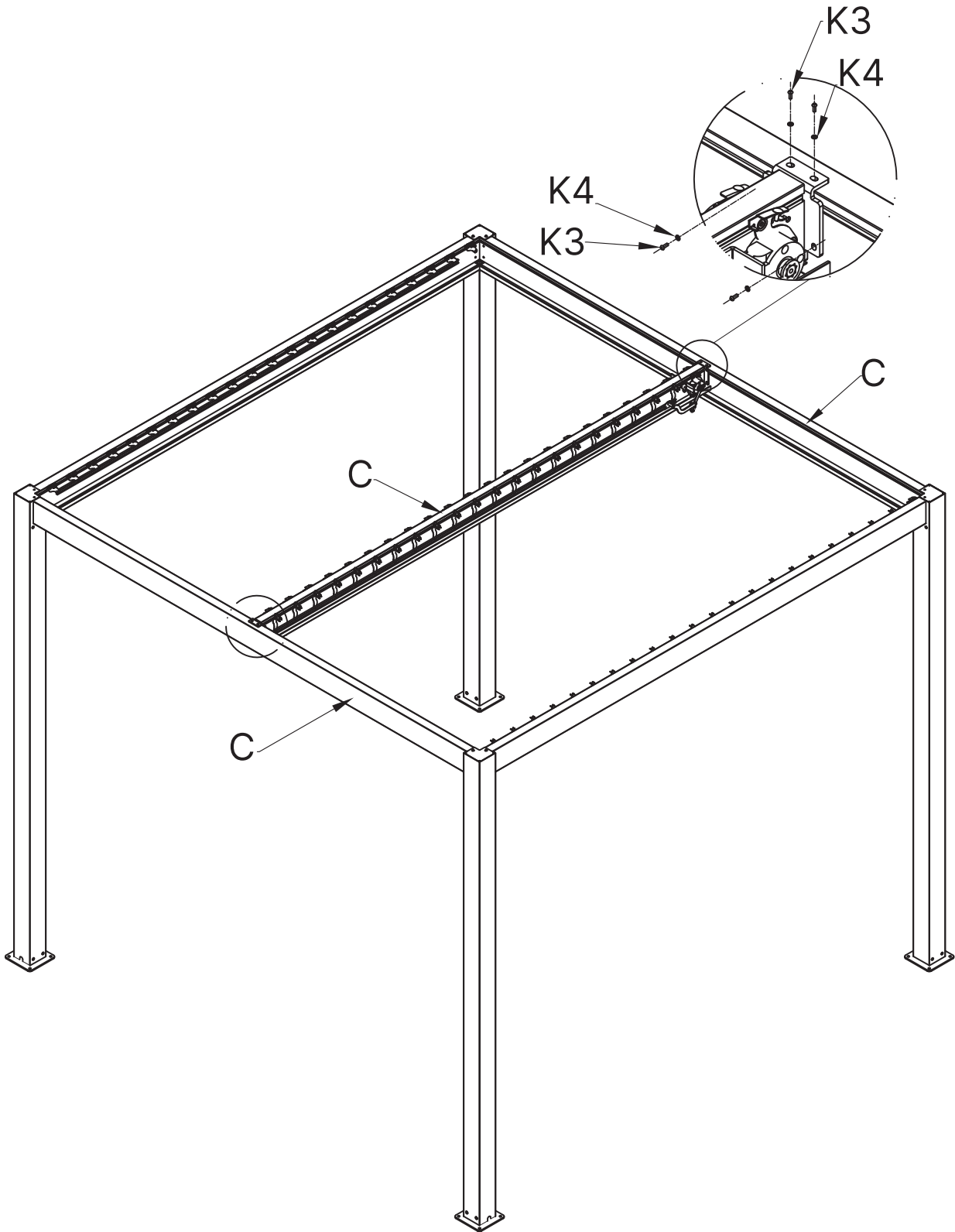

K3

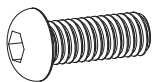

8 pcs

K4



8 pcs

12. Insert the louver E into the louver support lower part of both beams according to the drawing, then press downward the louver into its support according to the drawing position 1 and position 2.

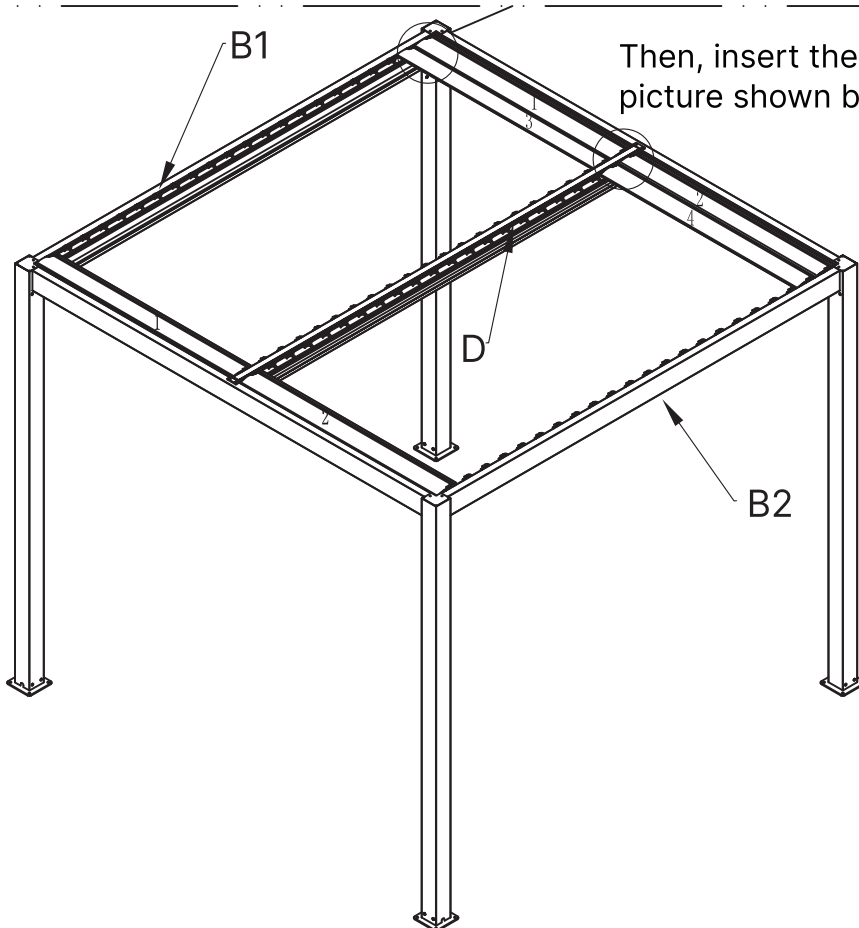
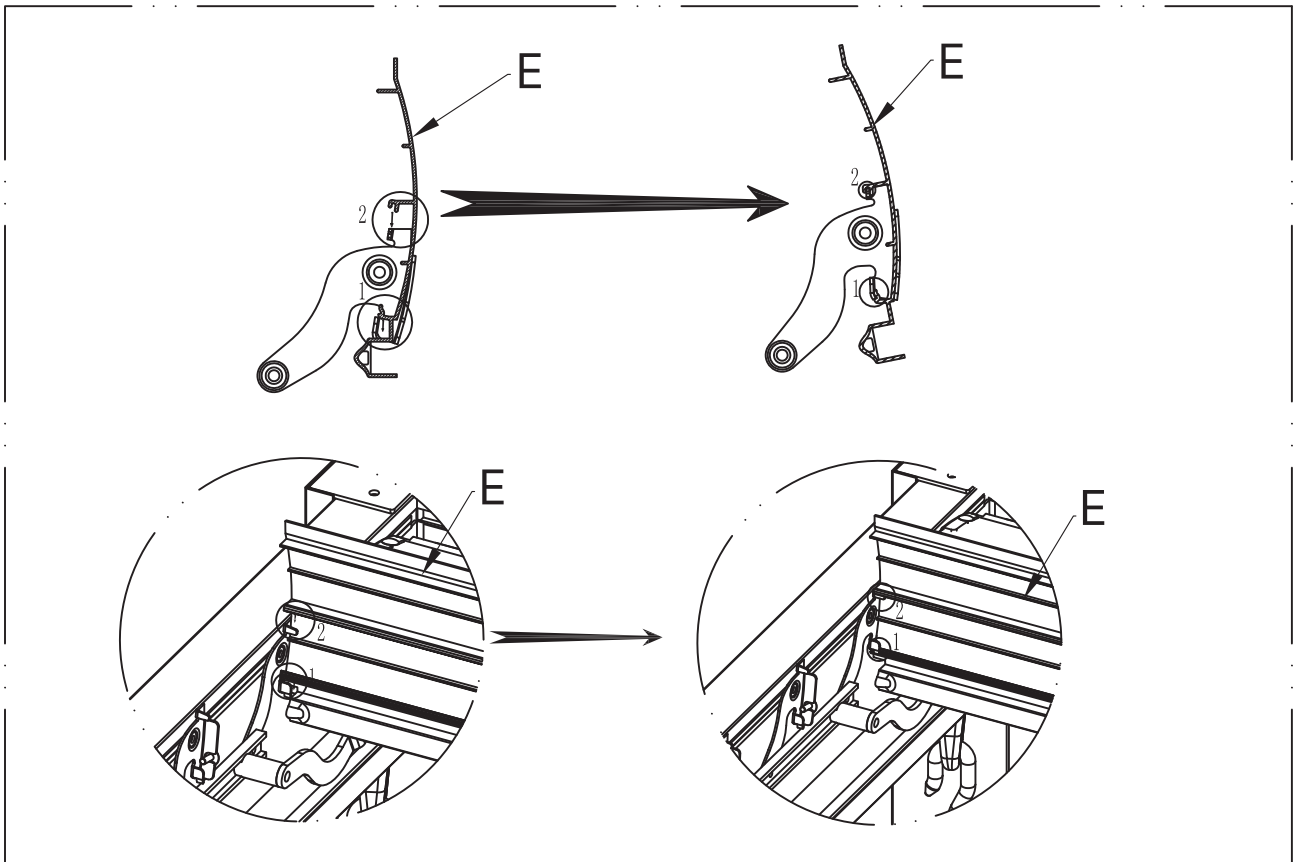

Then, insert the 6 pcs louvers as the picture shown below.

13. Put the gasket K4 onto the screw K3 firstly, align them with the holes in the lower side part of the middle beam C, and tighten up all screws. Then, insert all the rest louvers on the roof.

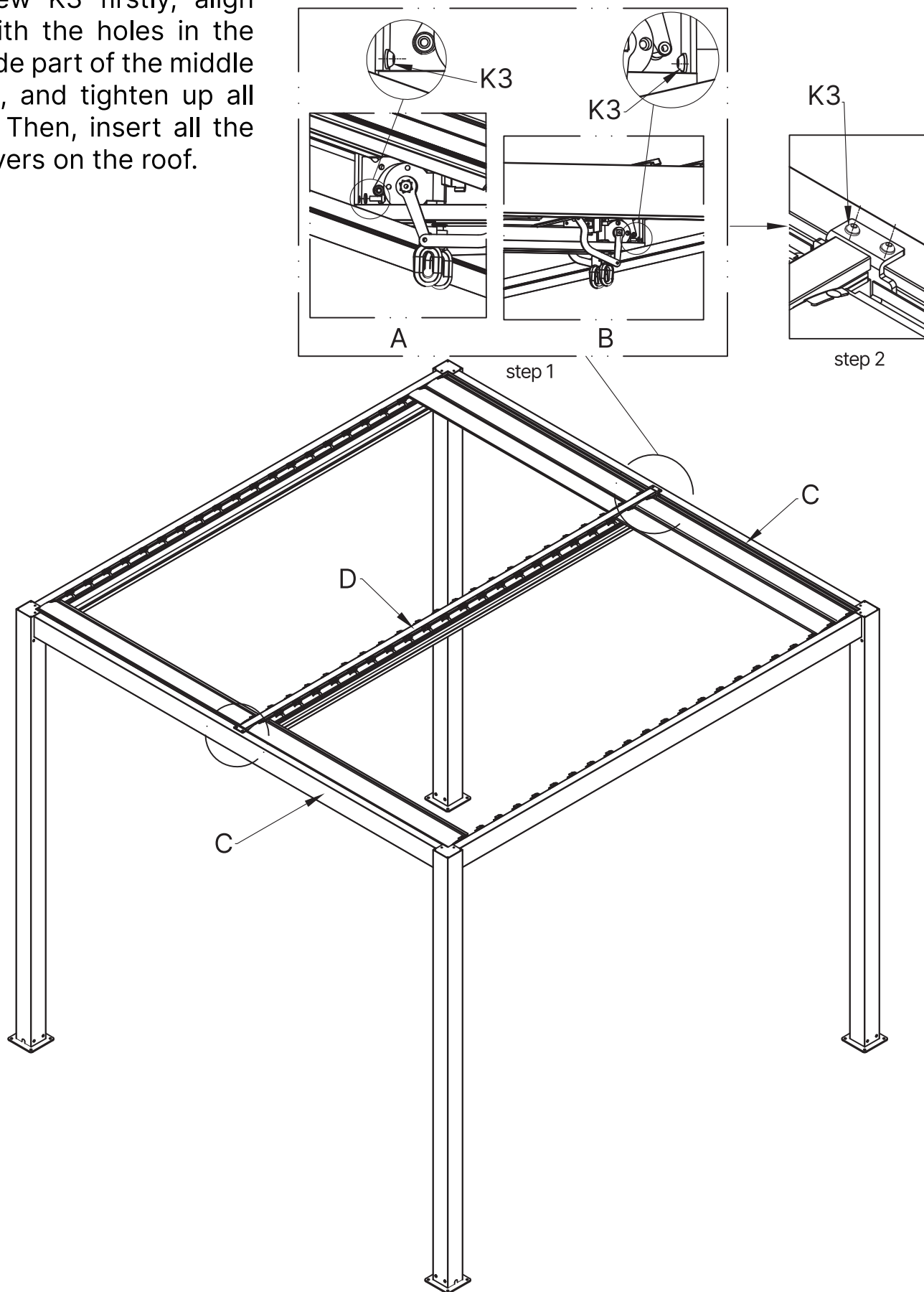

14. Install all plastic plugs on both louver ends.

Step 1. As the drawing shown, if the holes are not aligned, it needs to be adjusted.

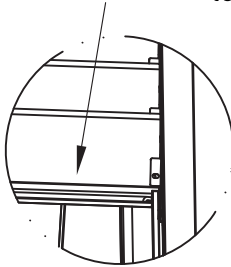

Step 2. As the drawing shown, insert the screw driver into position 1, and rotate the louver support by the direction 2 so as to align two holes.

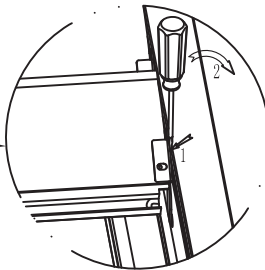

Step 3. After this adjustment, two holes are centered.

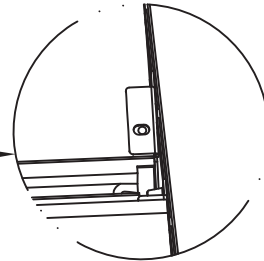

Step 4. Install the plastic plugs N on the first two fixed louvers firstly.

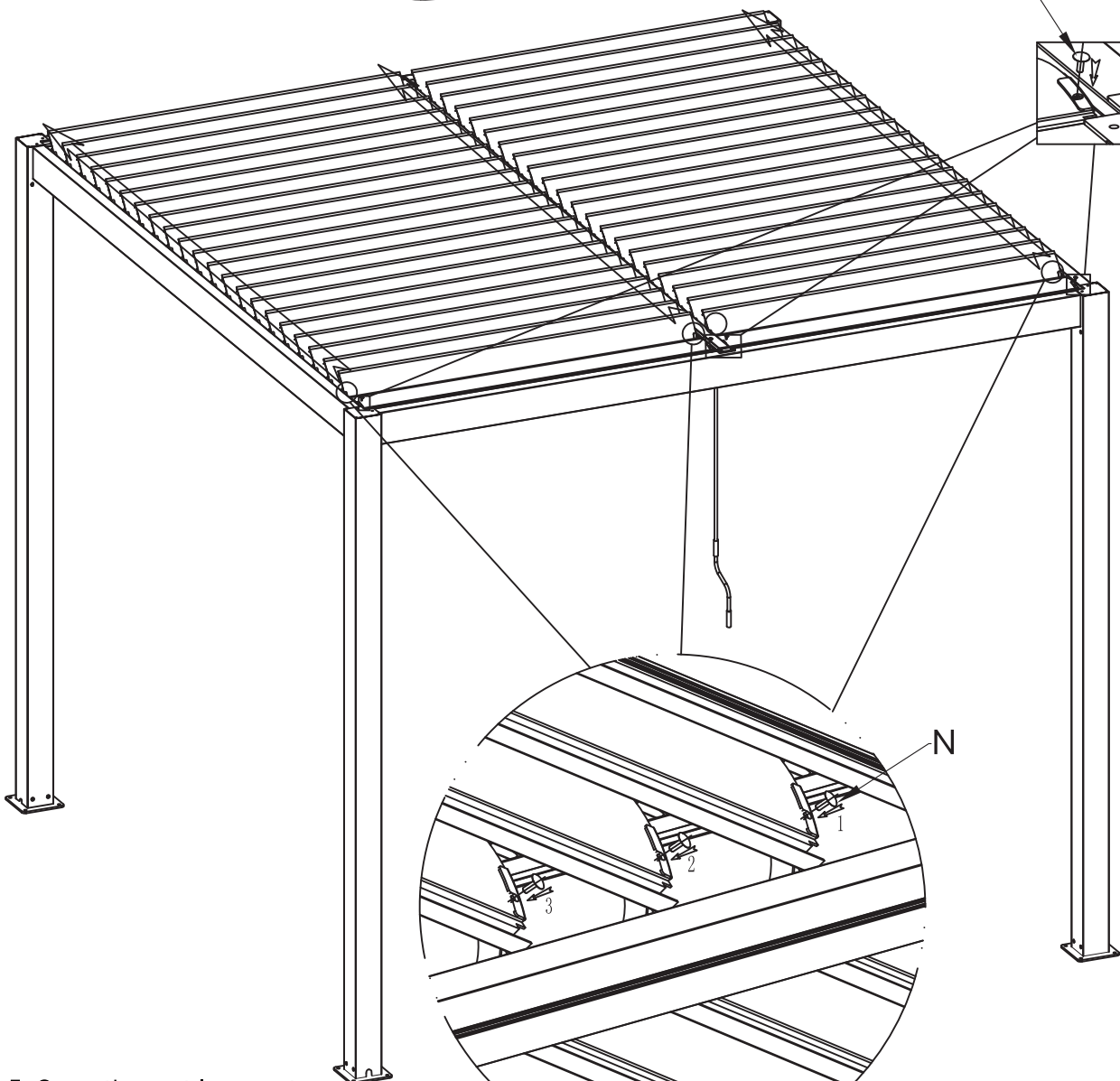
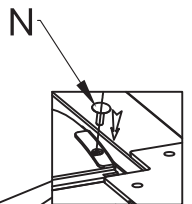

Step 5. Open the rest louvers to 45 degree, insert all the rest plastic plugs N one by one as the image shown.

15. Hook the handle crank M on the gear box ring, and rotate it to open or close the roof to complete this installation.

