

kitchen Baker's Rack

Étagère à pâtisserie de cuisine Bestier

Bestier Küchen-Bäckerregal

Bestier cremagliera per cucina

Estante de panadería Bestier Kitchen

Bestierキッチンベーカールック

Bestier厨房置物架

A

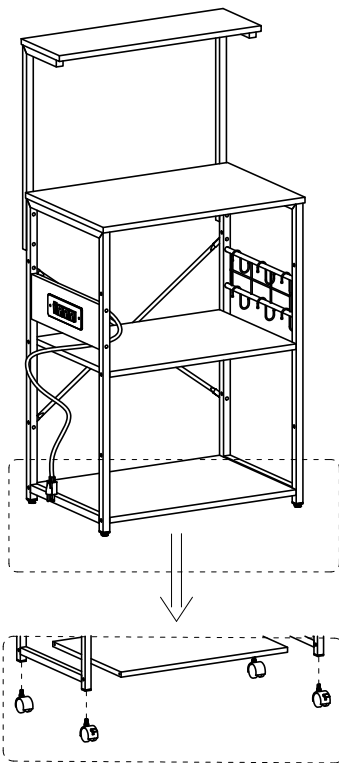

B

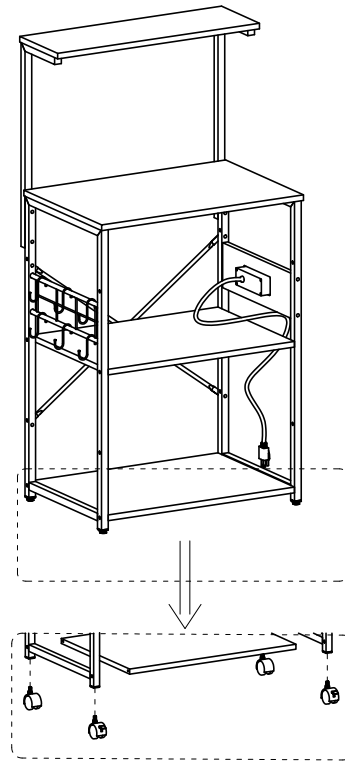

ASSEMBLY INSTRUCTION

Montageanleitung
Instructions De Montage
Istruzioni Per L'assemblaggio
Instrucciones De Montaje
組立説明書
安装说明书



HELPFUL HINTS

BEFORE YOU START

- Inspect product packaging to ensure the appearance is good.
- Read the assembly instruction carefully and follow it step by step.
- To avoid any scratching, putting a soft blanket on the floor is suggested.
- Identify, sort and count all the parts with tags.
- Find out installation position according to the drawing and install it in correct steps.



OTHER

- People needed for assembly: 1-2.
- Estimated assembly time: 0.5-1h.

CAUTION

- Be cautious when using a power drill or power screwdriver.
- Please be aware to slow down and stop when screw is nearly tight.
- Do Not use any harsh chemicals or abrasive cleaners for this item.
- Push, pull or drag this item carefully.

ASTUCES UTILES

AVANT DE COMMENCER

- Inspectez l'emballage du produit pour vous assurer que l'apparence est bonne.
- Lisez attentivement les instructions de montage et suivez-les étape par étape.
- Pour éviter toute rayure, posez une couverture douce sur le sol est suggéré.
- Identifiez, triez et comptez toutes les pièces avec des étiquettes.
- Trouver la position d'installation selon le dessin et l'installer dans les étapes correctes.



AUTRE

- Personnes nécessaires pour l'assemblage : 1-2.
- Temps de montage estimé : 0.5-1 h.

AVERTIR

- Soyez prudent lorsque vous utilisez une perceuse électrique ou un tournevis électrique.
- Veuillez être conscient de ralentir et d'arrêter lorsque la vis est presque serrée.
- N'utilisez pas de produits chimiques corrosifs ou de nettoyants abrasifs pour cet article.
- Poussez, tirez ou tirez cet article avec précaution.

CONSEJOS ÚTILES

ANTES DE EMPEZAR

- Inspeccione el paquete del producto para asegurarse de que la apariencia es buena.
- Lea atentamente las instrucciones de montaje y sígalas paso a paso.
- Para evitar rayas, se sugiere poner una manta suave en el suelo.
- Identifique, clasifique y enumere todas las piezas con etiquetas.
- Averigüe la posición de instalación según el dibujo e instálela en los pasos correctos.



OTROS

- Personas necesarias para el montaje: 1-2.
- Tiempo de montaje estimado: 0.5-1 h.

PRECAUCIÓN

- Tenga cuidado al utilizar un taladro eléctrico o un destornillador eléctrico.
- Tenga en cuenta que debe hacerlo más despacio y detenerse cuando el tornillo esté casi apretado.
- No utilice productos químicos agresivos ni limpiadores abrasivos para este artículo.
- Empuje, tire o arrastre este elemento con cuidado.

SUGGERIMENTI UTILI

PRIMA DI INIZIARE

- Controllare la confezione del prodotto per assicurarsi che sia in buono stato.
- Leggere con attenzione le istruzioni per l'assemblaggio e seguirle passo dopo passo.
- Per evitare graffi al pavimento, suggeriamo di stendervi una coperta morbida.
- Identificare, suddividere e contare tutte le parti con etichetta.
- Trovare la posizione adatta per il montaggio in base al disegno e montare lo scaffale seguendo correttamente i vari passaggi.



ALTRO

- Persone necessarie per l'assemblaggio: 1-2.
- Tempo di assemblaggio stimato: 0.5-1 ora.

ATTENZIONE

- Prestare molta attenzione quando si utilizza un trapano elettrico o un cacciavite elettrico.
- Rallentare con accortezza e fermarsi quando una vite è già sufficientemente serrata.
- Non utilizzare prodotti chimici aggressivi o detergenti abrasivi su questo articolo.
- Spingere, tirare o trascinare questo articolo con cautela.

NÜTZLICHE HINWEISE

⚠️ BEVOR SIE BEGINNEN

- Überprüfen Sie die Produktverpackung auf Schäden.
- Lesen Sie sich die Montageanleitung sorgfältig durch und befolgen Sie sie Schritt für Schritt.
- Um etwaiges Zerkratzen zu vermeiden, wird das Auslegen einer weichen Decke auf dem Boden empfohlen.
- Identifizieren, sortieren und zählen Sie alle Teile mit Tags nach.
- Identifizieren Sie die Montageposition gemäß der Zeichnung und bauen Sie das Regal den richtigen Schritten entsprechend auf.

⚠️ SONSTIGES

- Für den Zusammenbau erforderliche Anzahl an Menschen: 1-2.
- Ungefähre Montagedauer: 0.5-1 h.

⚠️ VORSICHT

- Seien Sie bei der Verwendung einer Bohrmaschine oder eines Akkuschraubers vorsichtig.
- Bitte vergessen Sie nicht darauf, langsamer zu werden und zu stoppen, sobald die Schraube fast festgezogen ist.
- Verwenden Sie keinerlei aggressive Chemikalien oder scheuernden Reinigungsmittel für dieses Produkt.
- Schieben oder ziehen Sie dieses Produkt vorsichtig.

温馨提示

⚠️ 安装前注意事项

- 检查产品包装, 确保外观良好。
- 仔细阅读安装说明, 按步骤操作。
- 为了避免刮伤, 建议在地板上放一条柔软的毯子。
- 标识、分类和清点所有部件。
- 根据图形找到安装孔位, 按正确步骤安装。

⚠️ 其他:

- 组装所需人员: 1-2人。
- 预计组装时间: 0.5-1小时。

⚠️ 注意:

- 小心使用电钻或电动螺丝刀。
- 当螺丝快要拧紧时, 请注意减速。
- 不要使用任何刺激性化学物质或擦洗剂。
- 当推、拉或拖动产品时, 注意小心谨慎, 防止损坏。

役に立つヒント

⚠️ 組立の場所を確保し、順番通りに組み立てる

- 組立場所 (充分広くて平たい場 所) を確保してください。
- 床や壁、商品を傷つけないように、商品の下に厚めの布や段ボールなどを敷いてください。
- 組立の順番を守らないと、組立できなくなったり、商品を傷つけたりします。

⚠️ その他

- 組み立てに必要な人: 1-2。
- 組立時間: 約0.5~1時間。

⚠️ 部品を確認する

- ネジ類などの部品番号、形状を説明書の部品一覧で確認してください。
- 部品をなくさないように纏めて置いてください。
- 部品を取り出すときに使う分だけ取り出してください。

DETAILS

DETAILS
DÉTAILS/POINTS DE MONTAGE
NOTE PARTICOLARI

DETALLES
組み立てのポイント
詳細情報

UNIT:INCH/CM/厘米

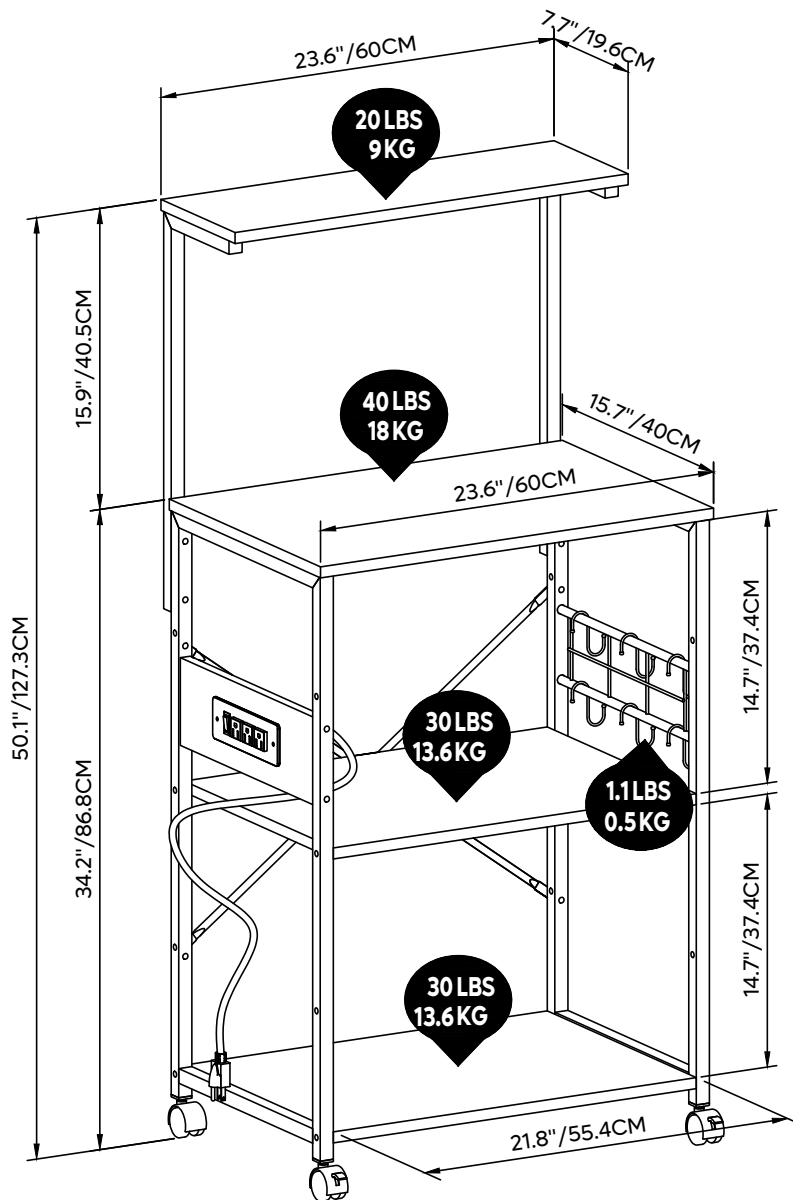

DETAILS

DETAILS
DÉTAILS/POINTS DE MONTAGE
NOTE PARTICOLARI

DETALLES
組み立てのポイント
詳細情報

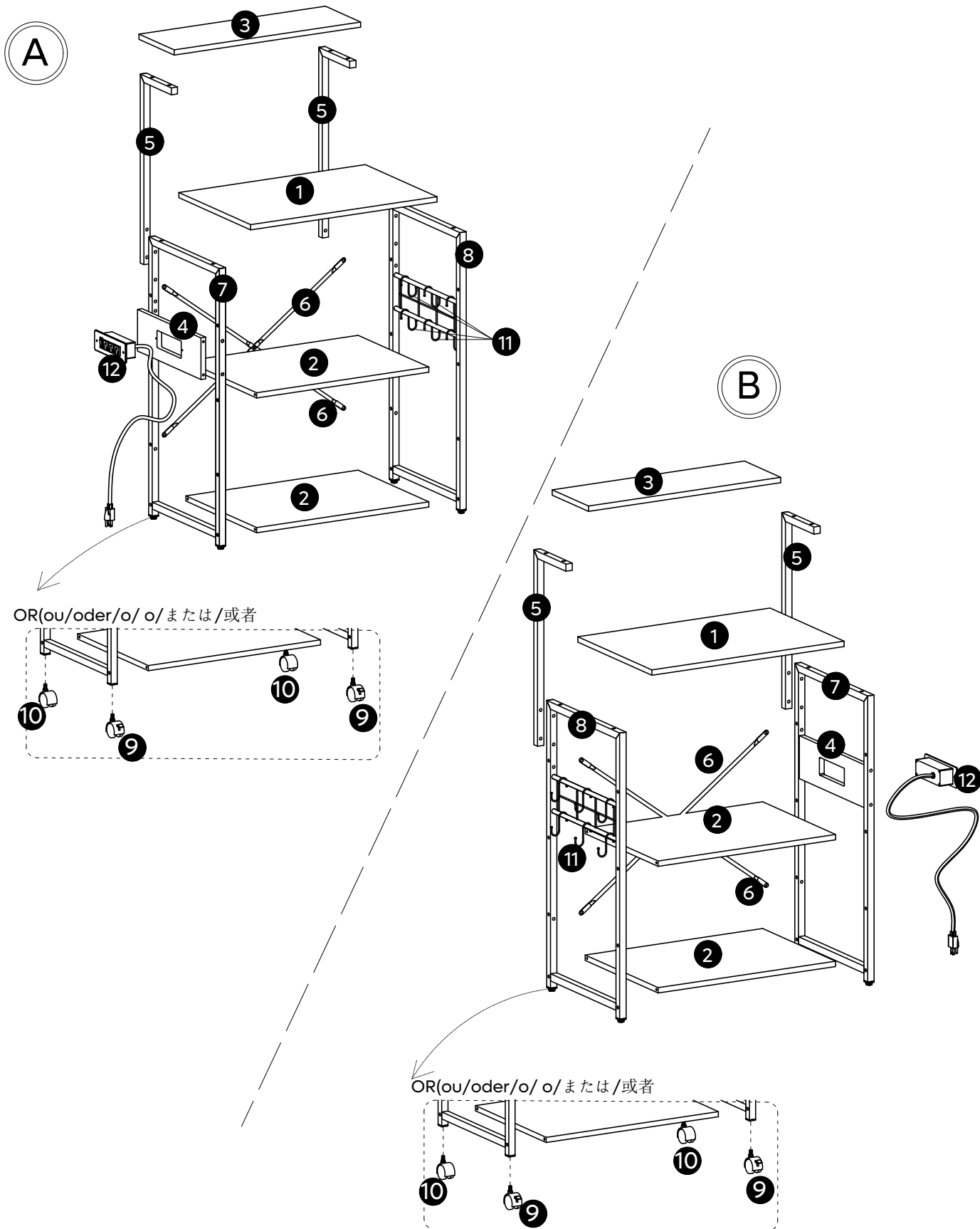

PART LIST

STÜCKLISTE
LISTE DES PIÈCES
ELENCO DEI PEZZI

LISTA DE PIEZAS
部品の確認
部件清单

①

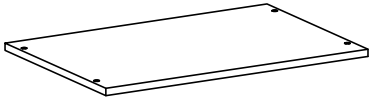

X1

②

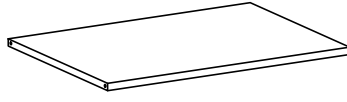

X2

③



X1

④

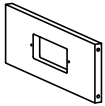

X1

⑤

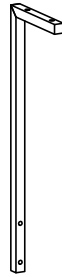

X2

⑥

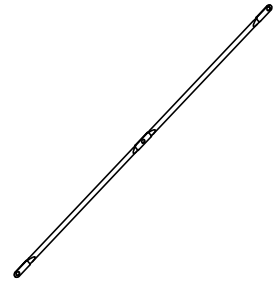

X2

⑦

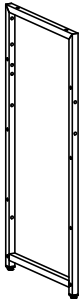

X1

⑧

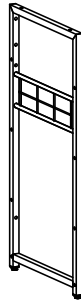

X1

⑨



X2

⑩

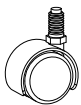

X2

⑪



X6



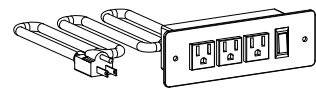







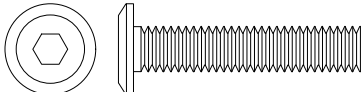

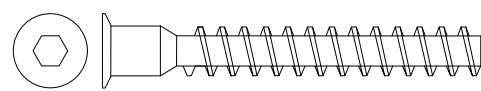
⑫

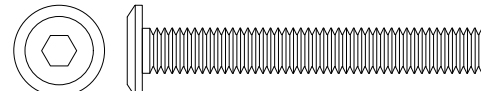
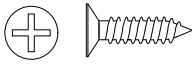

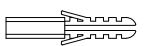
ACCESSORY LIST

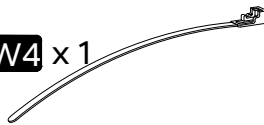
ZUBEHÖRLISTE
LISTE DES ACCESSOIRES
ELENCO DEGLI ACCESSORI

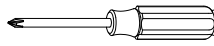
LISTA DE ACCESORIOS
付属品部品の確認
配件清單

A	M6x30mm	12+1	
B	M6x10mm	1	
C	ST7x50mm	12+1	
D	M6	9+1	
E	M6x45mm	4+1	
F	ST4x14mm	2	
W		2	<div style="display: flex; justify-content: space-around;"> <div style="text-align: center;">  W1 x 1 ST4x38mm </div> <div style="text-align: center;">  W2 x 1 </div> </div> <div style="display: flex; justify-content: space-around; margin-top: 10px;"> <div style="text-align: center;">  W3 x 2 </div> <div style="text-align: center;">  W4 x 1 </div> </div>
			 M4  

A

Style A: Step 1-8,17
 Style A : Étape 1-8,17
 Ausführung A: Schritt 1-8,17
 Stile A: Step 1-8,17
 Estilo A: paso 1-8,17
 スタイルA: ステップ 1-8,17
 安装方式A: 步骤 1-8,17

B

Style B: Step 9-17
 Style B : Étape 9-17
 Ausführung B: Schritt 9-17
 Stile B: Step 9-17
 Estilo B: paso 9-17
 スタイルB: ステップ 9-17
 安装方式B: 步骤 9-17

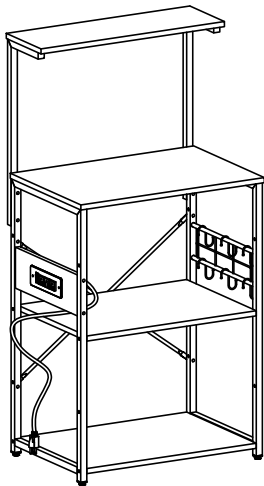

OR(ou/oder/o/ o/または/或者)

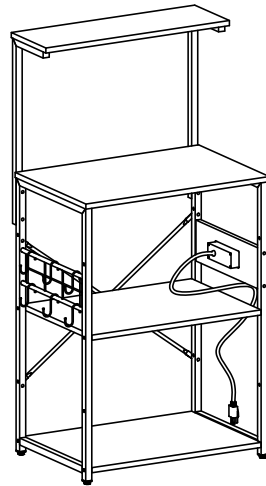
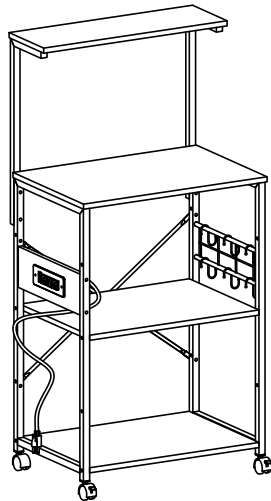

OR(ou/oder/o/ o/または/或者)

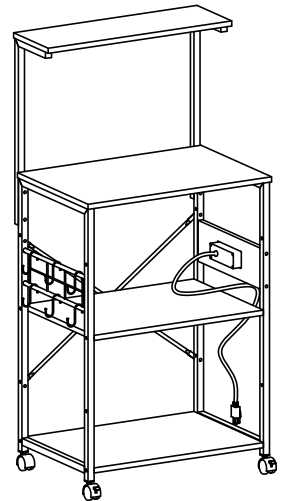

1

A

80% tighten
 80 % serré
 80% festziehen
 Serraggio al 80%
 80 % reforzado
 80%締め付け
 80%锁紧

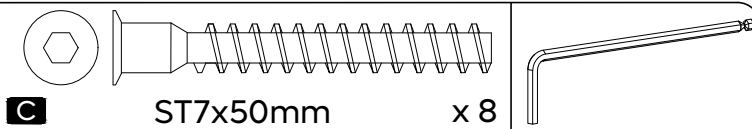
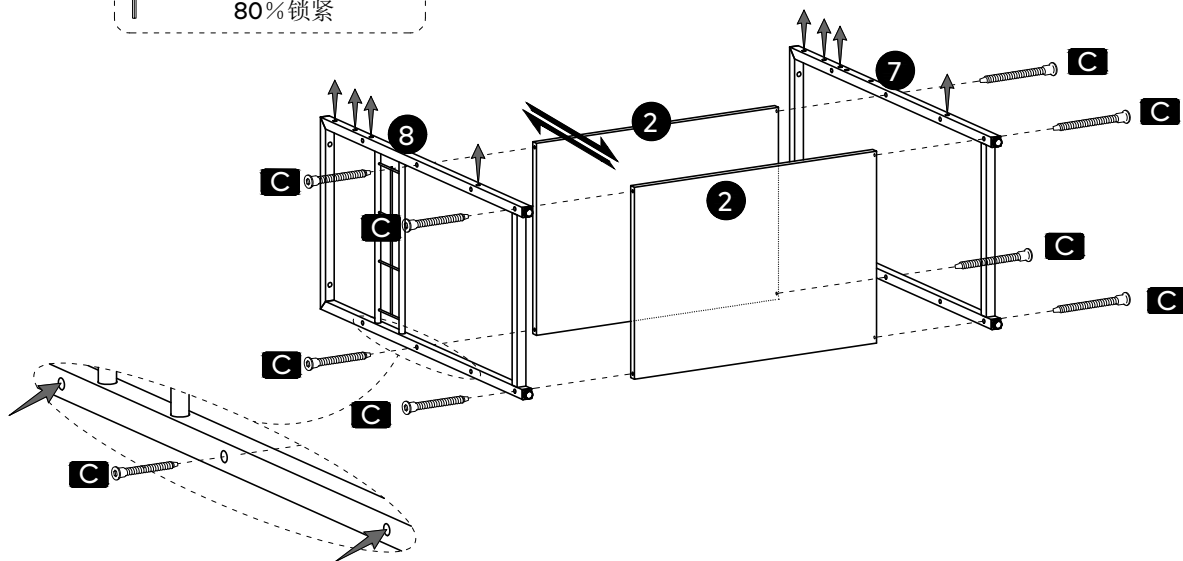

2

A

80% tighten
80 % serré
80% festziehen
Serraggio al 80%
80 % reforzado
80%締め付け
80%锁紧

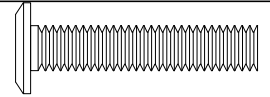
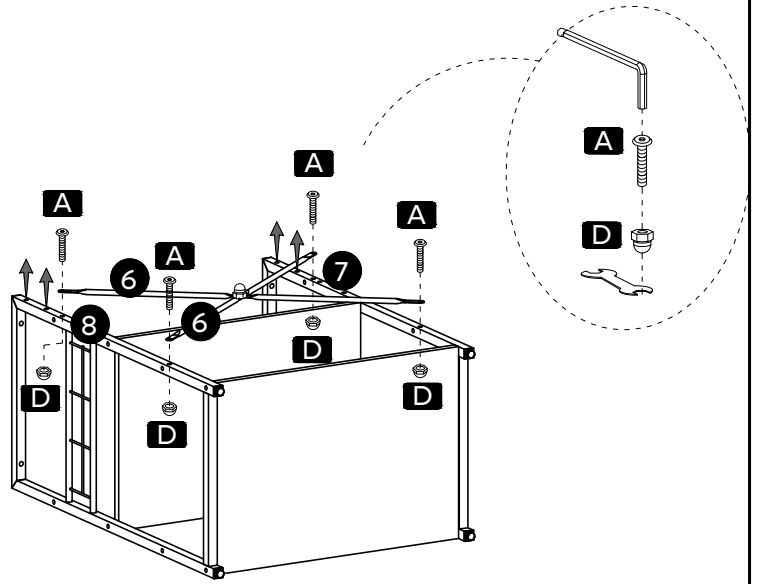
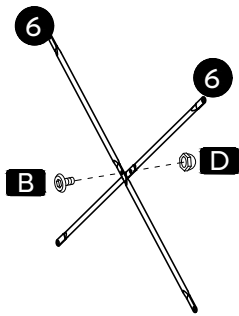

A M6x30mm x 4



B M6x10mm



x 5

D M6

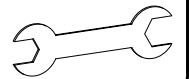

3

A

100% tighten
100 % serré
100% festziehen
Serraggio al 100%
100 % reforzado
100%締め付け
100%锁紧

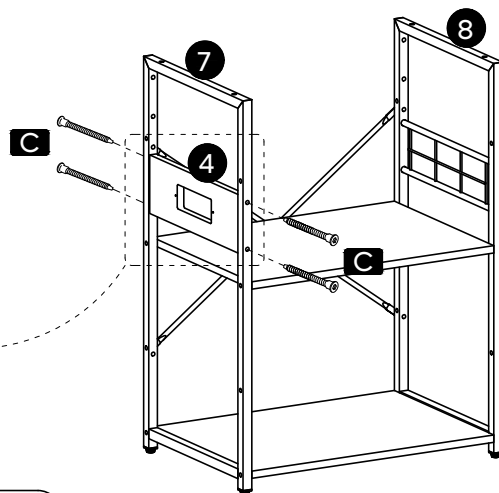
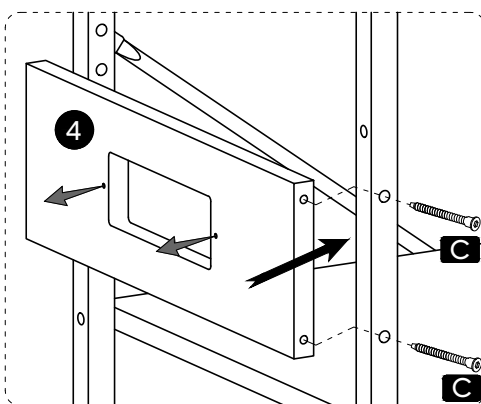

C ST7x50mm x 4



4

A

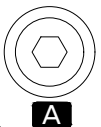
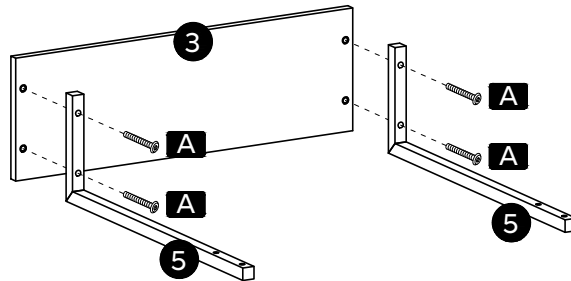

M6x30mm x 4

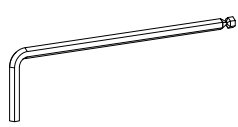

5

A

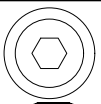
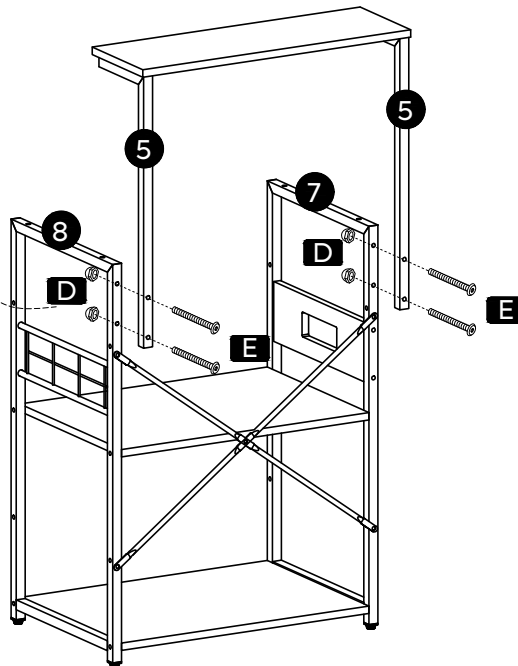
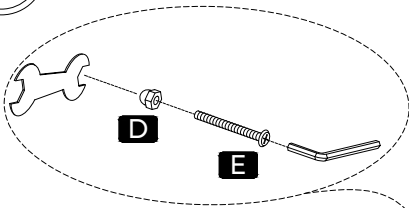

M6x45mm x 4

D M6 x 4

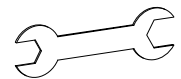
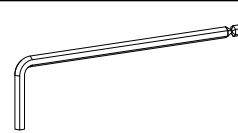

6

A

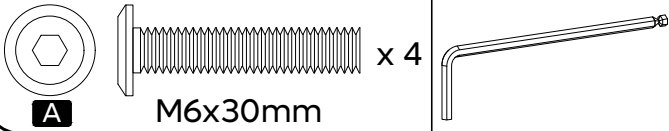
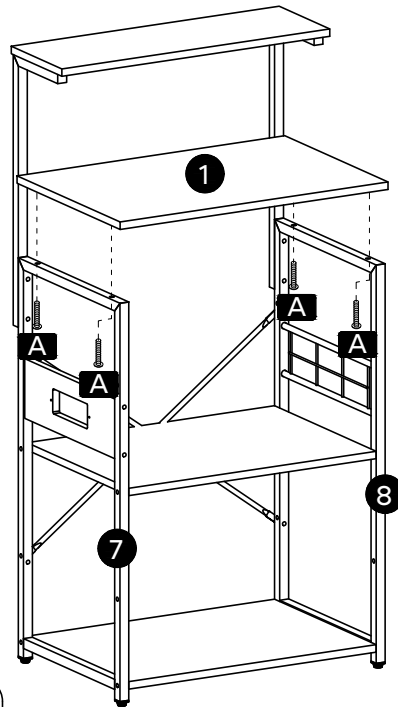

7

A

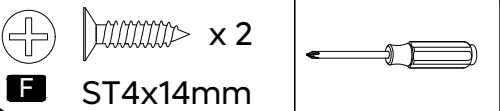
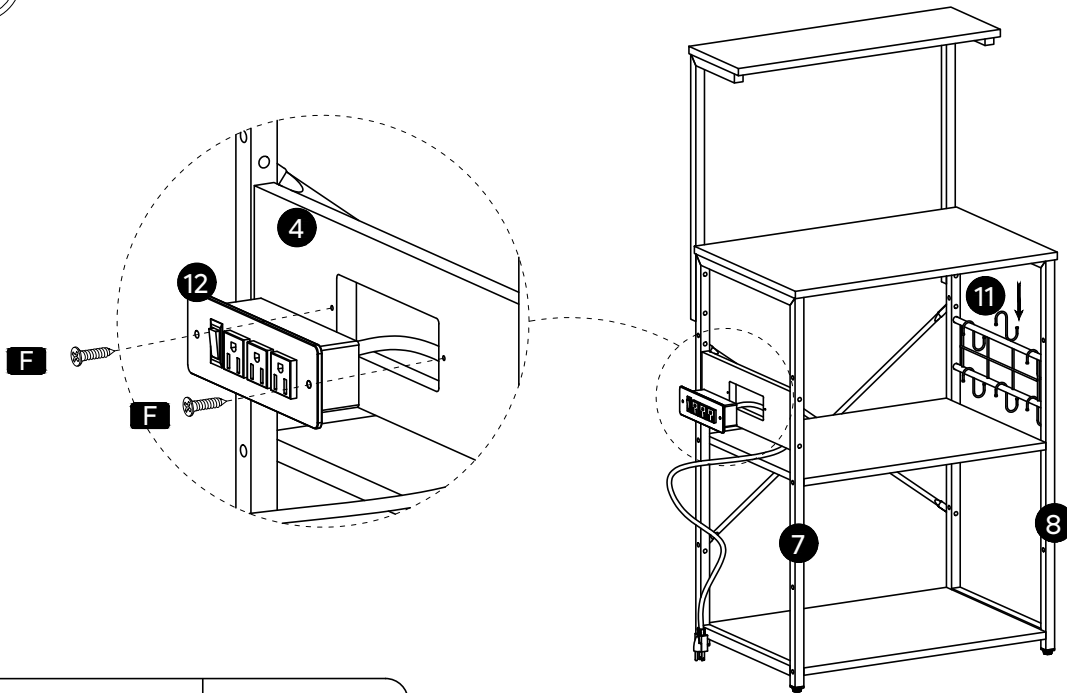

A

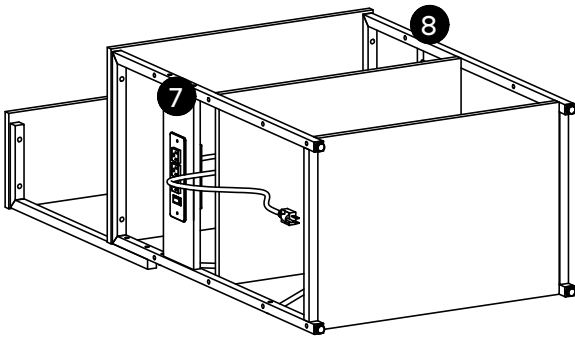

1

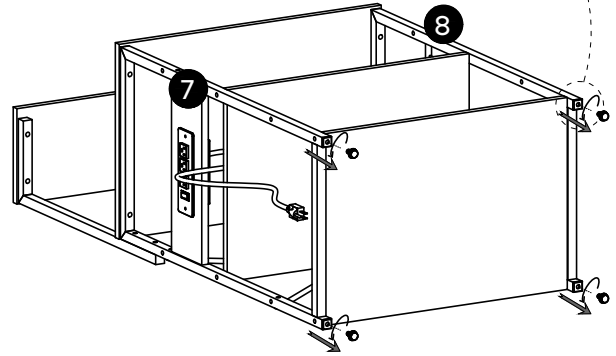

2

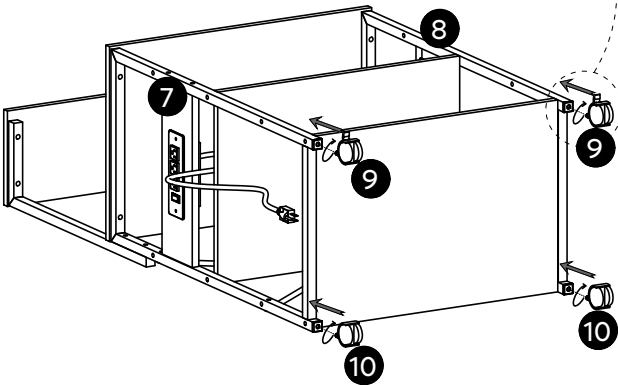
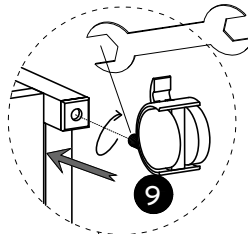

3

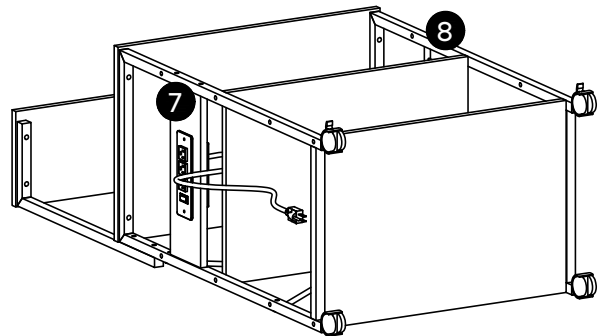

4

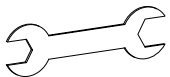

9

B

80% tighten
 80 % serré
 80% festziehen
 Serraggio al 80%
 80 % reforzado
 80%締め付け
 80%锁紧

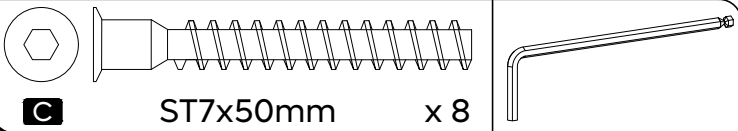
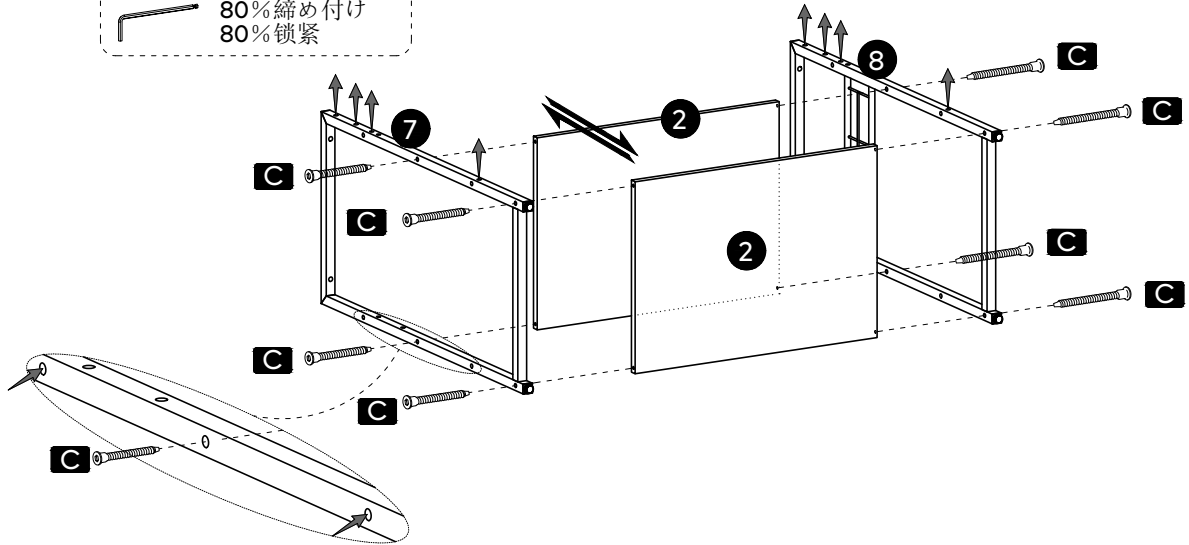

10

B

80% tighten
 80 % serré
 80% festziehen
 Serraggio al 80%
 80 % reforzado
 80%締め付け
 80%锁紧

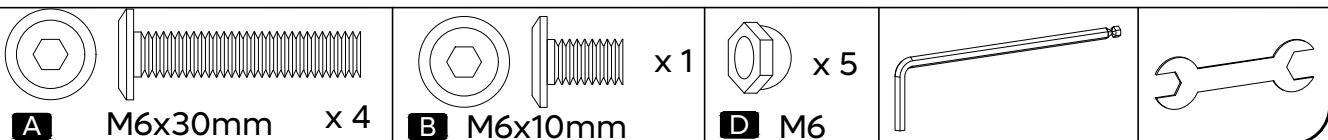
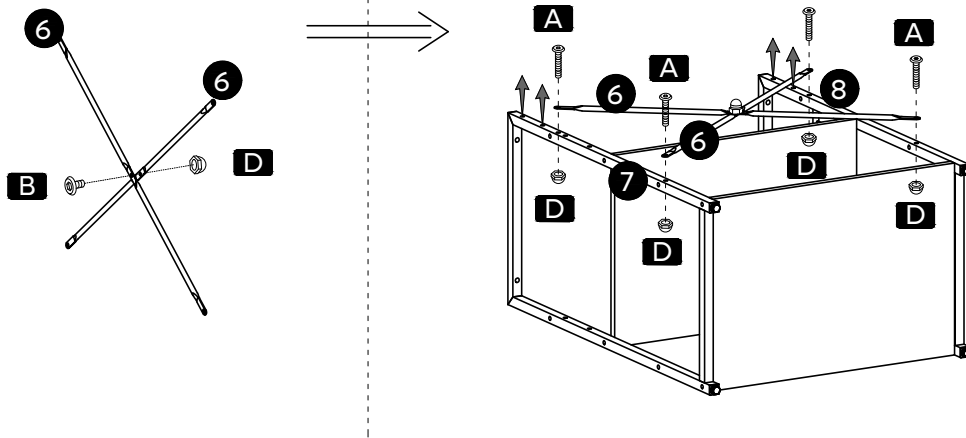

11

B

100% tighten
 100 % serré
 100% festziehen
 Serraggio al 100%
 100 % reforzado
 100%締め付け
 100%锁紧

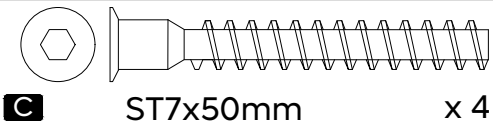
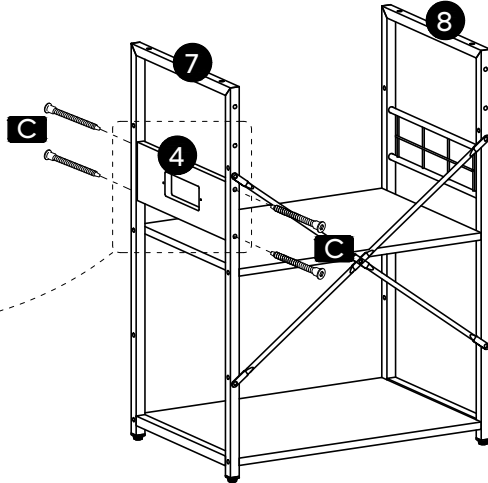
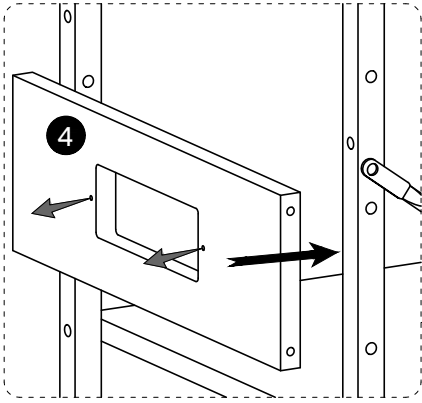

12

B

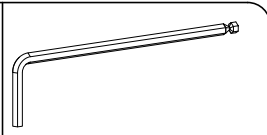
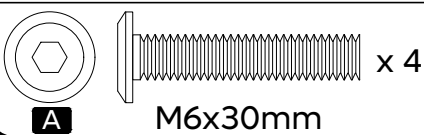
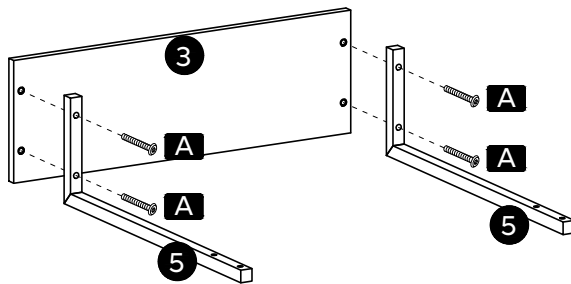

13

B

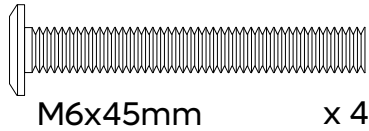
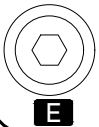
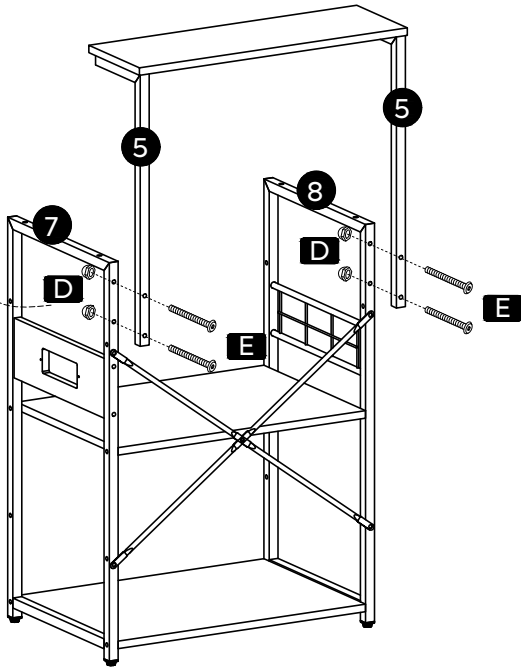
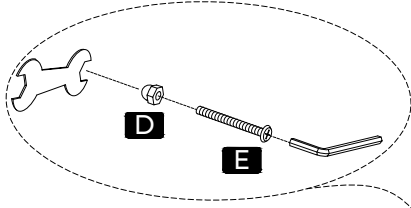

M6x45mm

x 4

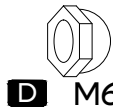

x 4

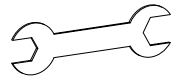

14

B

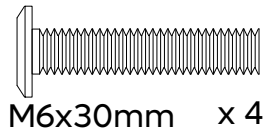
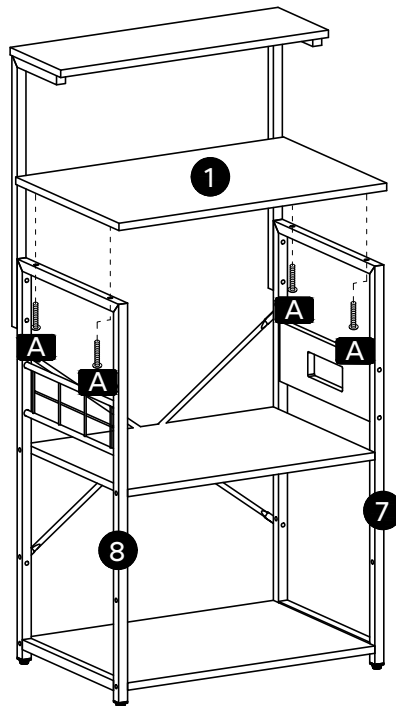

M6x30mm

x 4

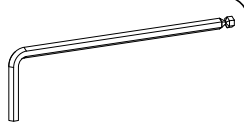

B

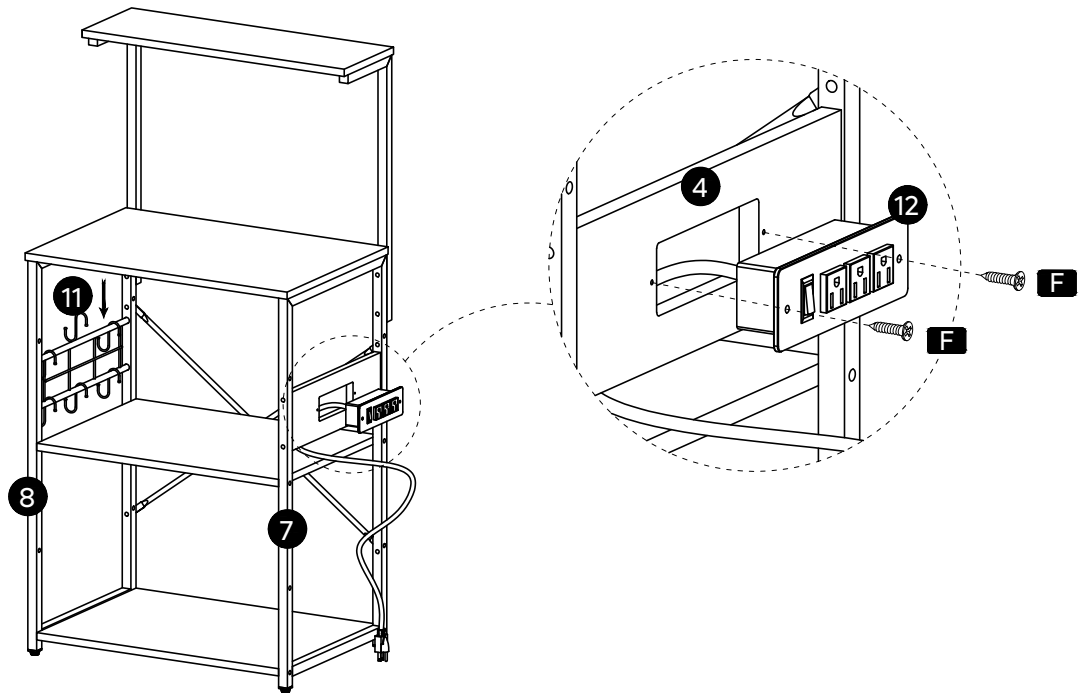

x 2

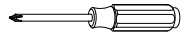

F ST4x14mm

B

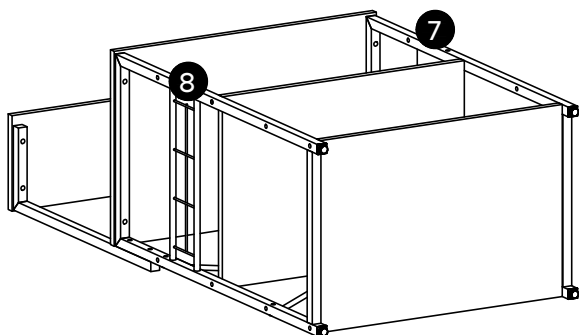

1

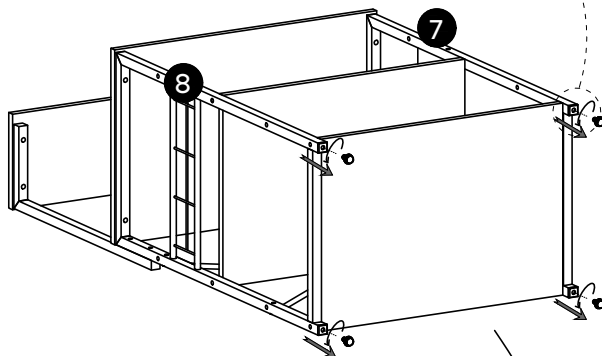

2

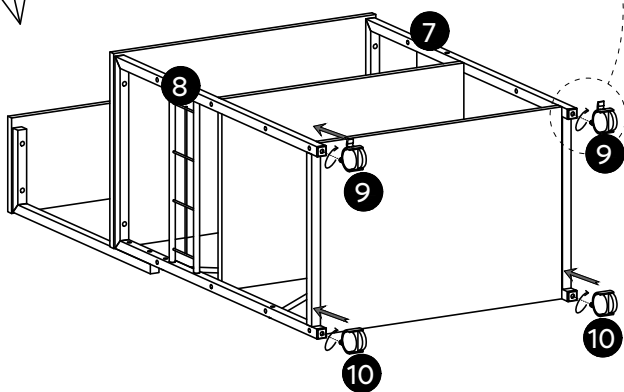
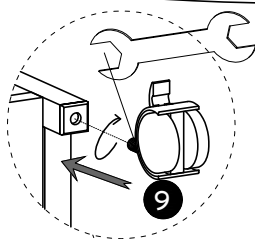

3

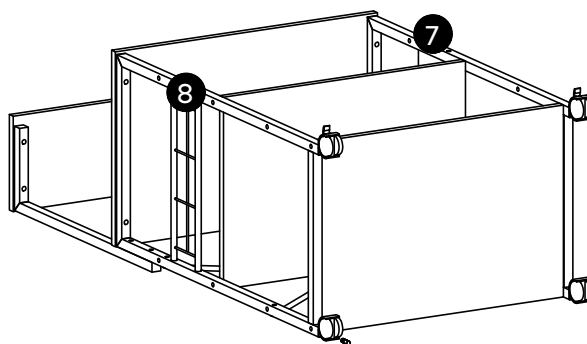

4

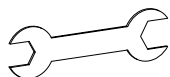

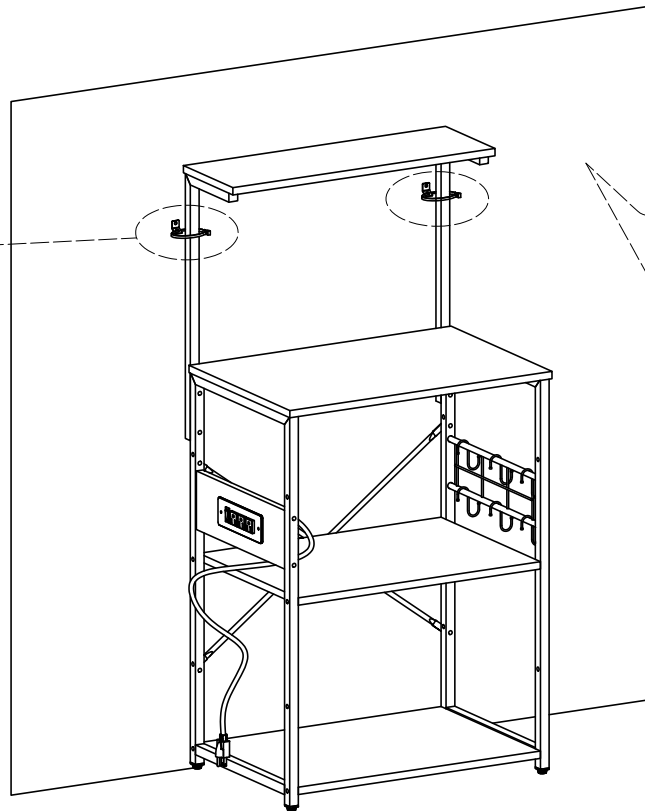
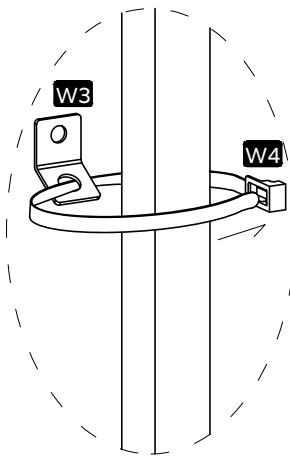
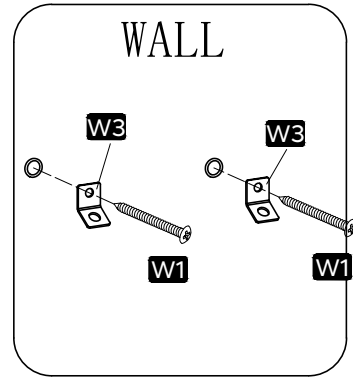
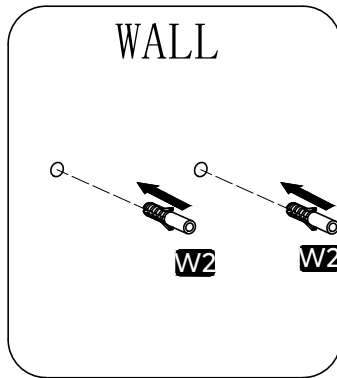
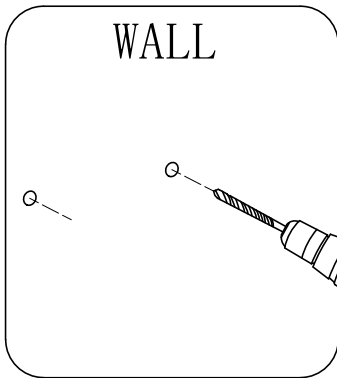

WALL
mur
WAND
PARETE
MURO
壁
墙体

W1 x 2  ST4x38mm

W2 x 2 

W3 x 2 

W4 x 2 

※ **Please fasten this item to wall for protection and safety.**

1. Drill 2 holes in the wall and insert W2 into holes.
※ You may need to use rubber mallet for tapping W2 .
2. Use W1 to attach W2 with W3 .
3. Use W4 to connect the corresponding W3s and tighten them as desired before locking in place.

※ **Veillez fixer ce buffet de salle à manger sur votre mur pour plus de protection et de sécurité.**

1. Percez 2 trous dans le mur et insérez W2 dans les trous.
※ Vous devrez peut-être utiliser un maillet en caoutchouc pour frapper W2.
2. Utilisez W1 pour connecter W2 avec W3.
3. Utilisez W4 pour connecter les W3s correspondant et serrez-les comme vous le souhaitez avant de verrouiller dans la place adaptée.

※ **Bitte befestigen Sie diesen Artikel zum Schutz und zur Sicherheit an der Wand.**

1. Bohren Sie 2 Löcher in die Wand und setzen Sie die W2 in die Löcher ein.
※ Möglicherweise müssen Sie einen Gummihammer zum Klopfen von W2 verwenden.
2. Verwenden Sie W1, um W2 mit W3 zu verbinden.
3. Verwenden Sie W4, um die entsprechenden W3s zu verbinden, und ziehen Sie sie wie gewünscht fest, bevor Sie sie verriegeln.

※ **Si prega di fissare questo articolo alla parete per protezione e sicurezza.**

1. Praticare 2 fori nella parete e inserire W2 nei fori.
※ Potrebbe essere necessario usare un martello di gomma per fissare il pezzo W2.
2. Utilizzare W1 per collegare W2 con W3.
3. Utilizzare W4 per collegare i W3 corrispondenti e stringerli a proprio piacimento prima di bloccarli in posizione.

※ **Fije este elemento a la pared como medida de protección y seguridad.**

1. Taladre 2 orificio en la pared e inserte el tornillo W2 en los orificios.
※ Es posible que tenga que utilizar el mazo de goma para golpear W2.
2. Utilice W1 para unir W2 con W3.
3. Utilice W4 para conectar los W3 correspondientes, y apriételes según sus preferencias antes de inmovilizarlos en su posición.

※ **安全のために、オープンシェルフを壁に固定してください。**

- 1、壁に2つ穴を開け、W2を穴に差し込む。
※ W2を叩くにはラバーハンマーが必要かもしれません。
- 2、W1を使用し、W2とW3を接続してください。
- 3、W4を使用して二つのW3を接続し、所定の位置にロックする前に必要に応じて締め付ける。

※ **请将此产品固定在墙上以防护和安全。**

- 1、在墙上钻2个孔，然后将W2插入孔中。
※您可能需要使用橡皮槌敲击W2。
- 2、用W1将W2与W3连接。
- 3、用W4穿过对应的W3大孔，并按需要拉紧，然后锁定到位。