

Read this instruction carefully. See hardware and furniture part list for guidance. Be sure all parts are complete, before you assemble. Place all wooden furniture parts on a clean and flat soft surface to prevent from being scratched. Follow the figure to start assembling.

CAUTIONS : 1. Do not FULLY - TIGHTEN the nut or nut bolt until all nut or bolt is ready assembled.
 2. Do not OVER - TIGHTEN the nut or bolt to avoid causing damages to the thread.
 3. Keep all hardware parts out of reach of children.

NOTE : THE LIST AND QUANTITY SHOWN ARE FOR 1 UNIT ASSEMBLY.
 Tool needed : Screwdriver & Rubber Mallet (not provider).

PART LIST		
ITEM	DESCRIPTION	QTY
A	HEADBOARD	1 PC
B	HEADBOARD LEG	2 PCS
C	HEADBOARD SUPPORT WOOD	2 PCS
D	HEADBOARD SUPPORT RAIL	1 PC
E	FOOTBOARD	1 PC
F	SIDE RAIL	2 PCS
G	BED LEG	4 PCS
H	CENTER RAIL	2 PCS
I	CENTER SUPPORT LEG	6 PCS
J	CENTER SUPPORT	3 PCS
K	BED SLAT	39 PCS

HARDWARE LIST		
ITEM	DESCRIPTION	QTY
1	JCBC BOLT M6 x 50mm	4 PCS
2	JCBB BOLT M8 x 45mm	10 PCS
3	M8 FLAT WASHER	10 PCS
4	M8 SPRING WASHER	10 PCS
5	BED SLAT SIDE FITTER	26 PCS
6	BED SLAT CENTER FITTER	26 PCS
7	WOOD SCREW M3.5 x 16mm	12 PCS
8	WOOD SCREW M4 x 20mm	4 PCS
9	M4 ALLEN KEY (BALL SHAPE)	1 PC
10	M5 ALLEN KEY (BALL SHAPE)	1 PC

STEP 1

Take out HEADBOARD LEG (B) ,HEADBOARD SUPPORT WOOD (C) & HEADBOARD SUPPORT RAIL (D) for the HEADBOARD BACK (A).

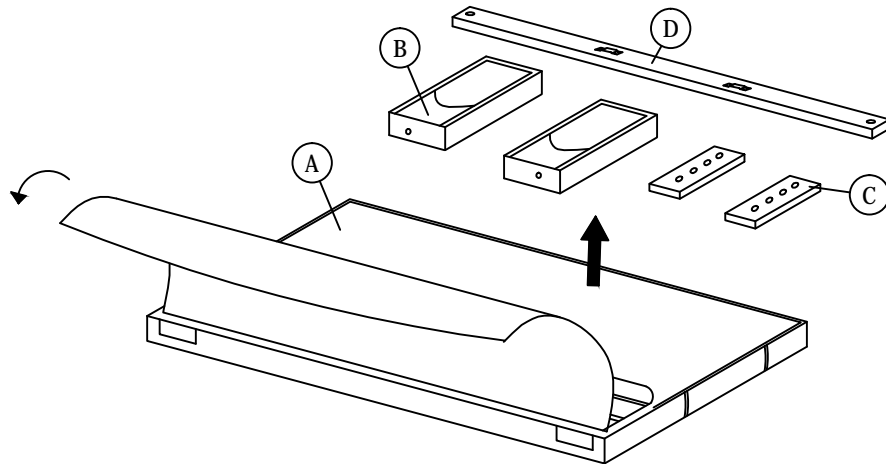

STEP 2

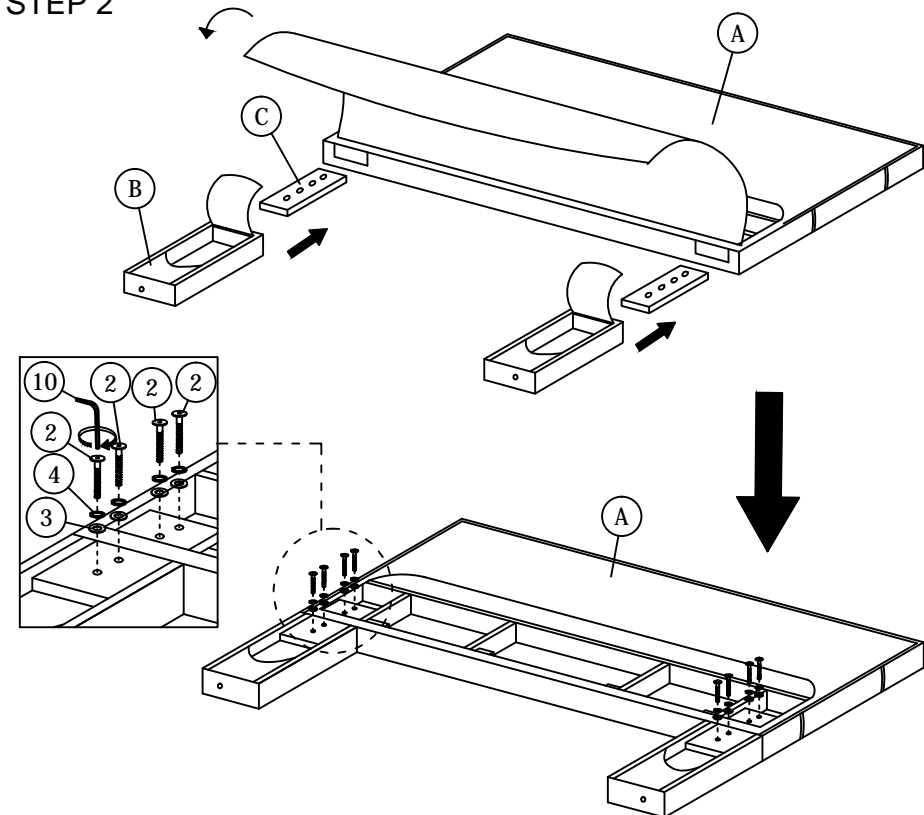

ASSEMBLY INSTRUCTIONS

STEP 3

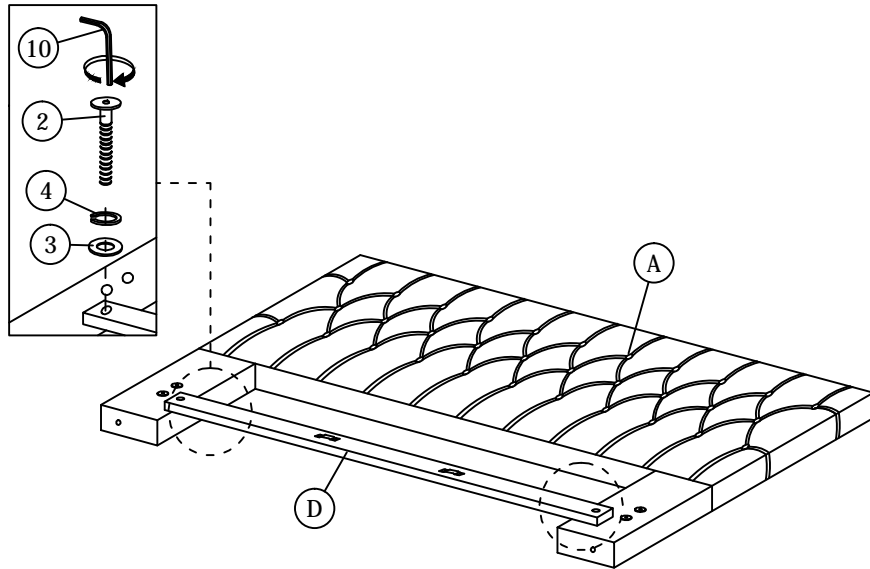

STEP 4

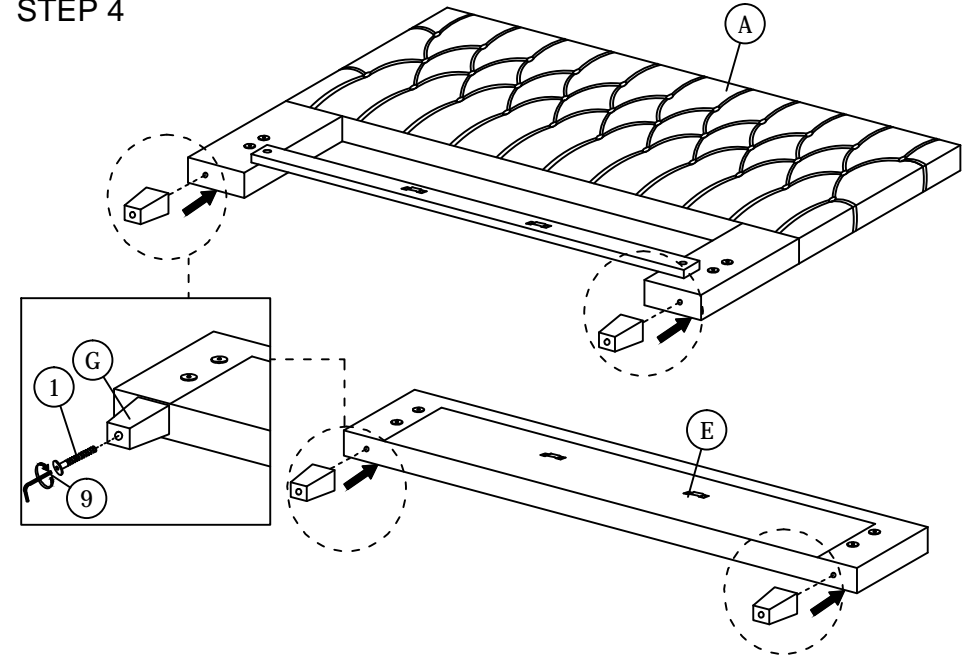

STEP 5

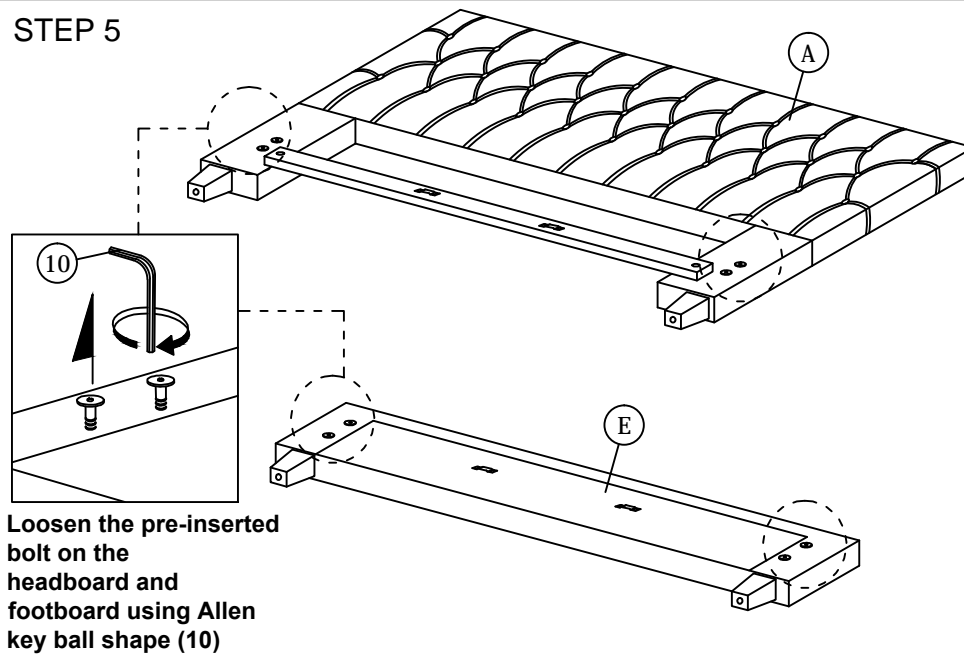

STEP 6

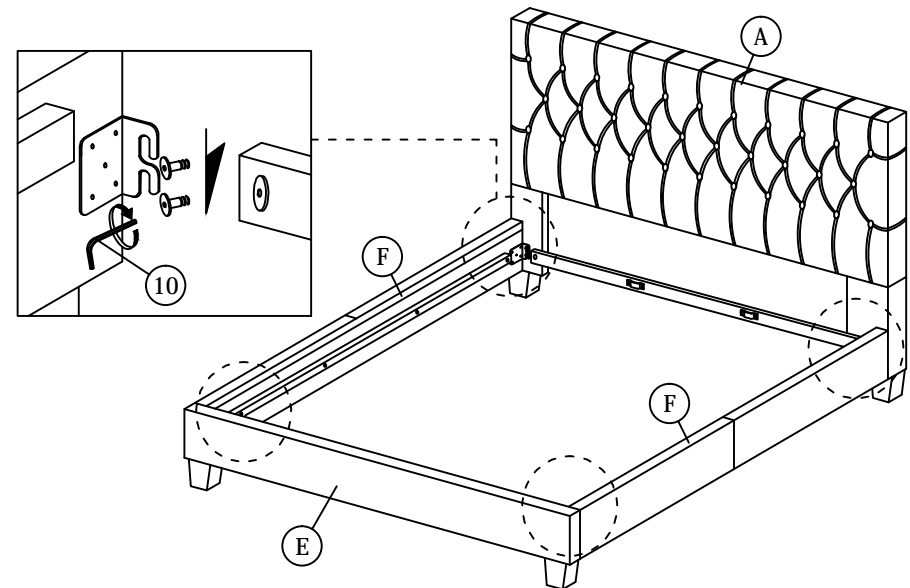

ASSEMBLY INSTRUCTIONS

STEP 7

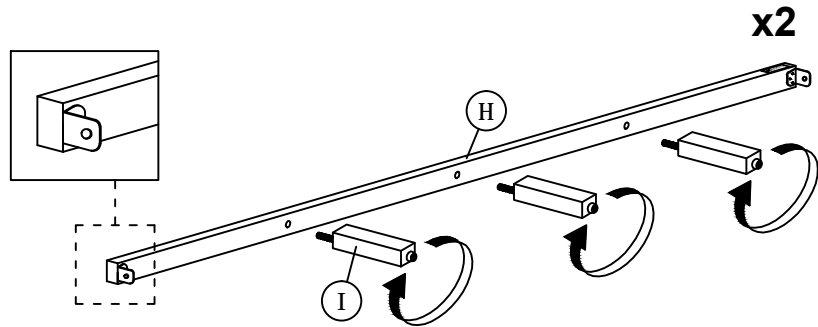

STEP 8

STEP 8.1

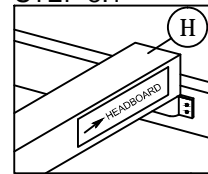

STEP 8.2

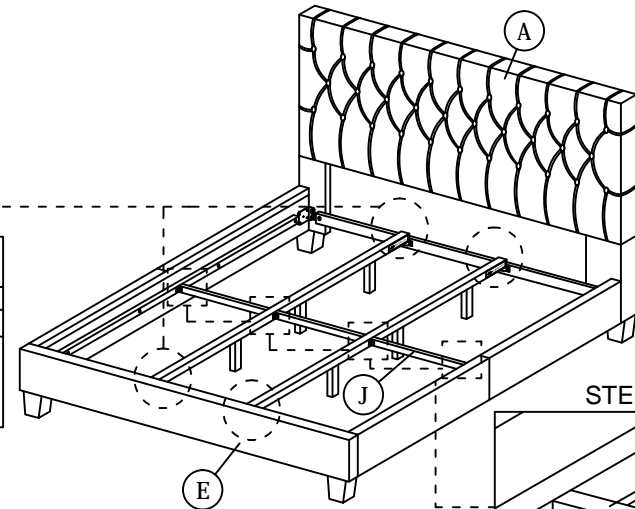
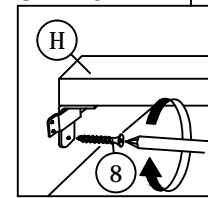

STEP 8.3

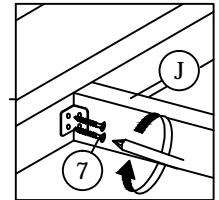

STEP 9

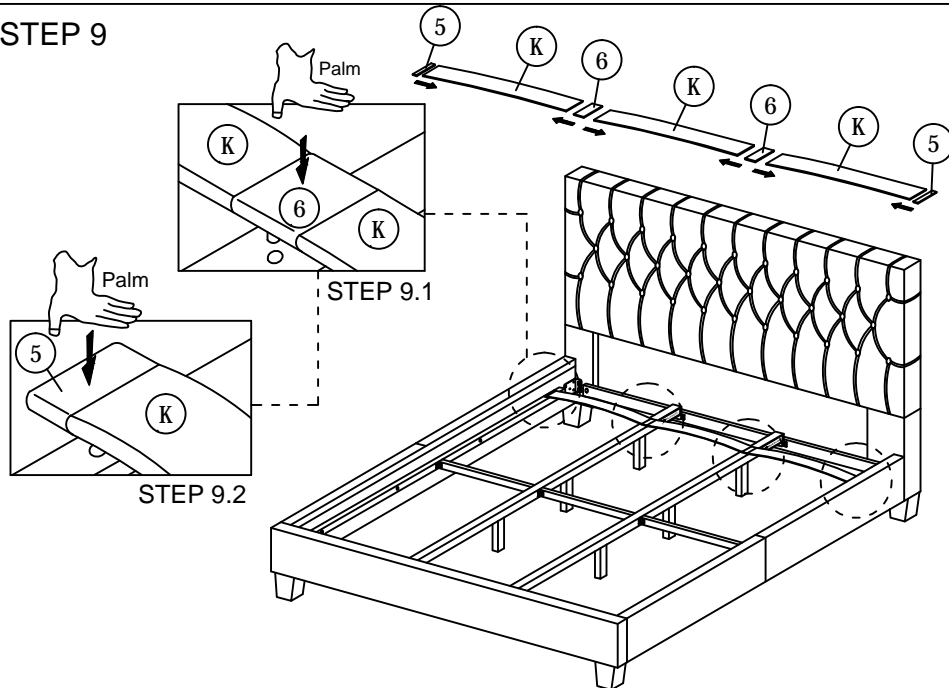

STEP 10

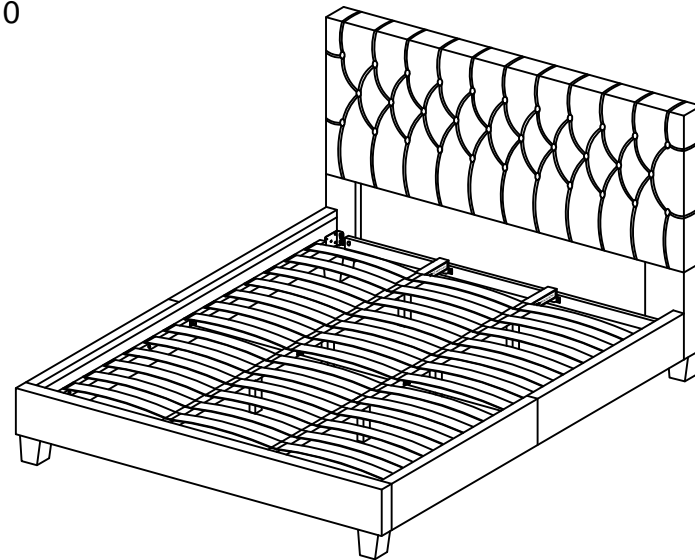

* When moving the bed position, the center support legs must be adjust to be straight to avoid any broken problem.