

Assembly Instructions

Plant Stand

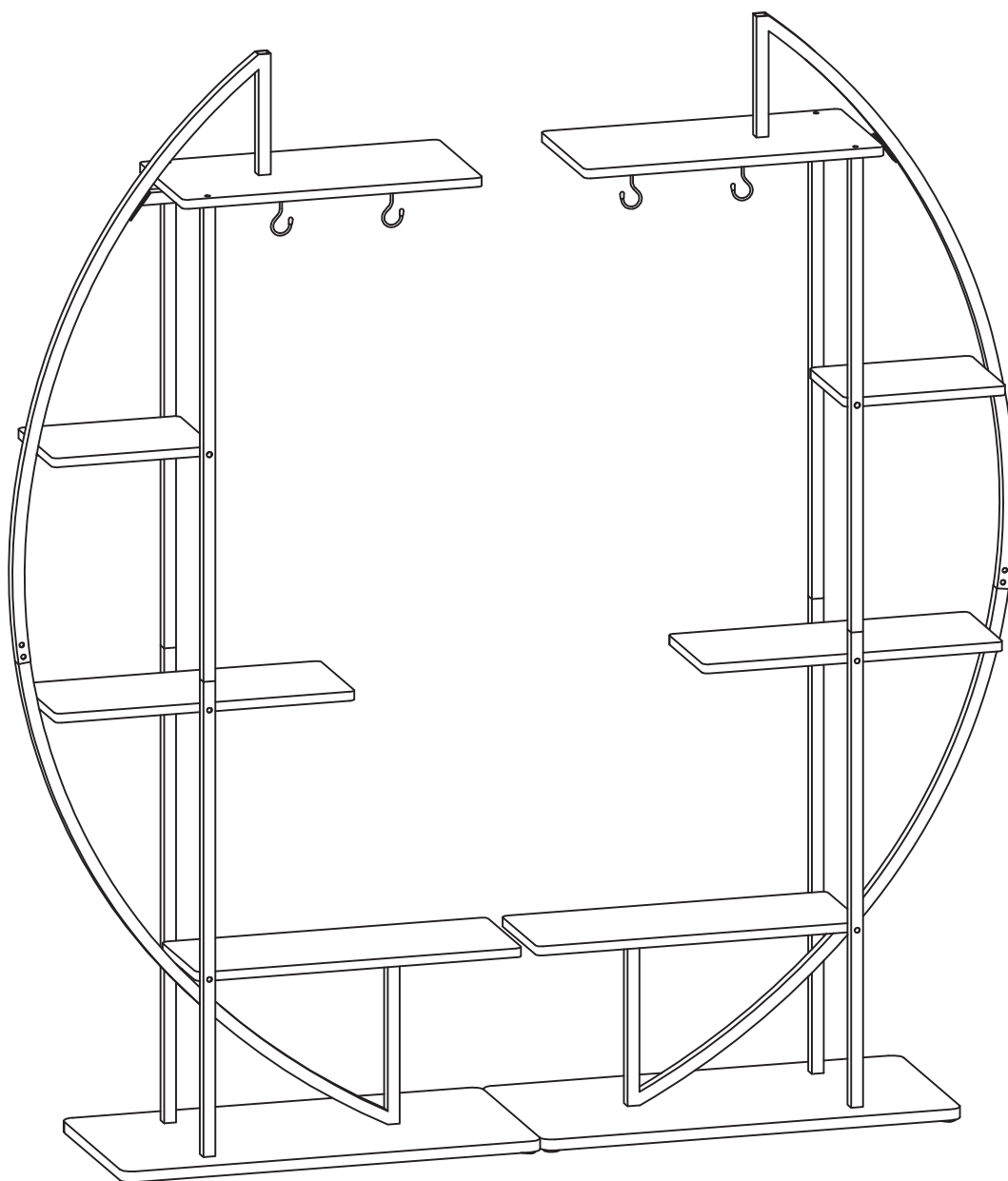

Two people are recommended for assembly

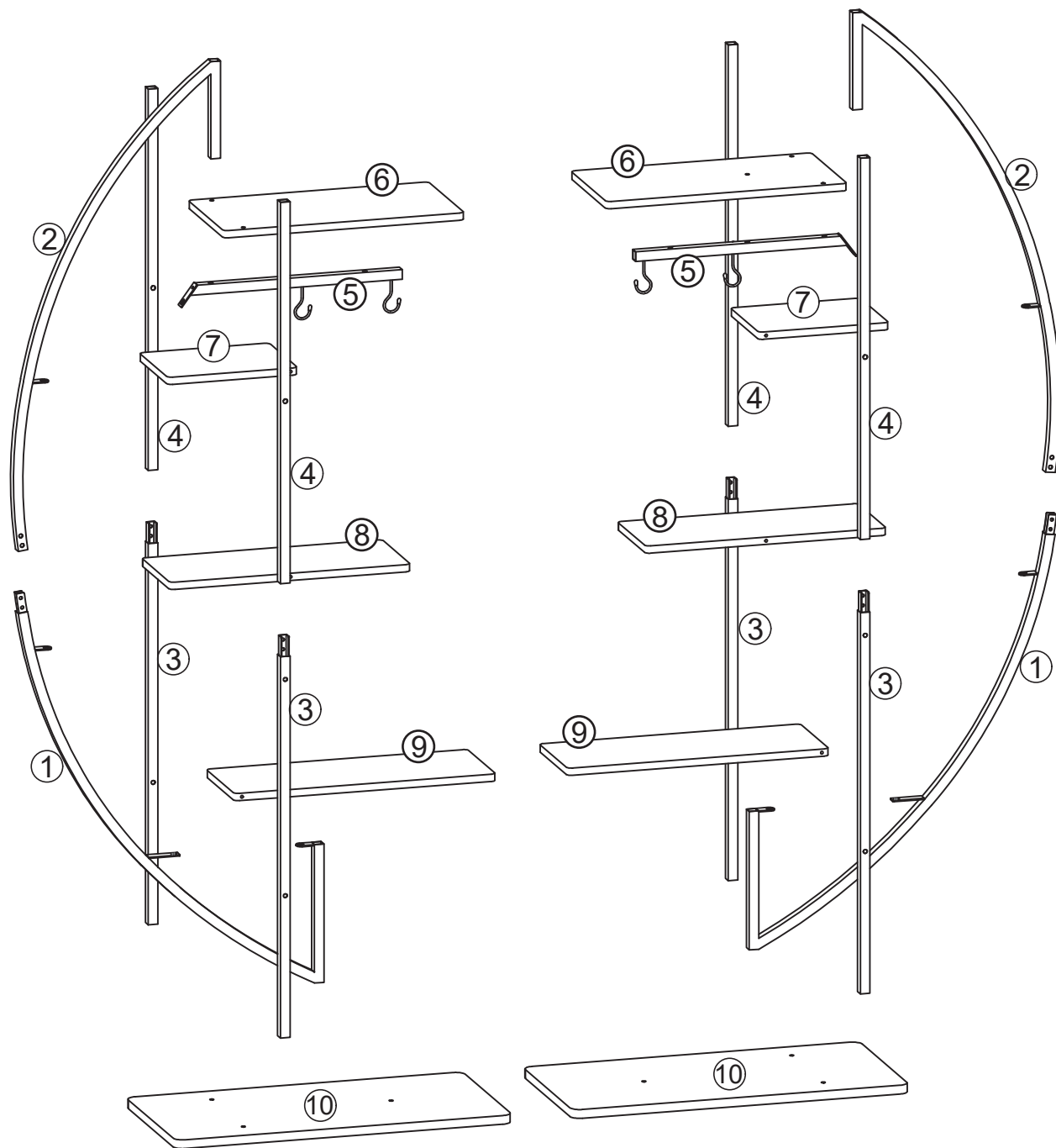

A	X16	B	X10	C	X4	D	X10	E	X2
M6*8mm		M6*12mm		M6*30mm		M6*40mm		M6*55mm	
F	X12	G	X2	H	X2	I	X2	J	X1
Φ7*47mm		4*35mm		Φ6*30mm		180*25mm		M6	

STEP 1

×2

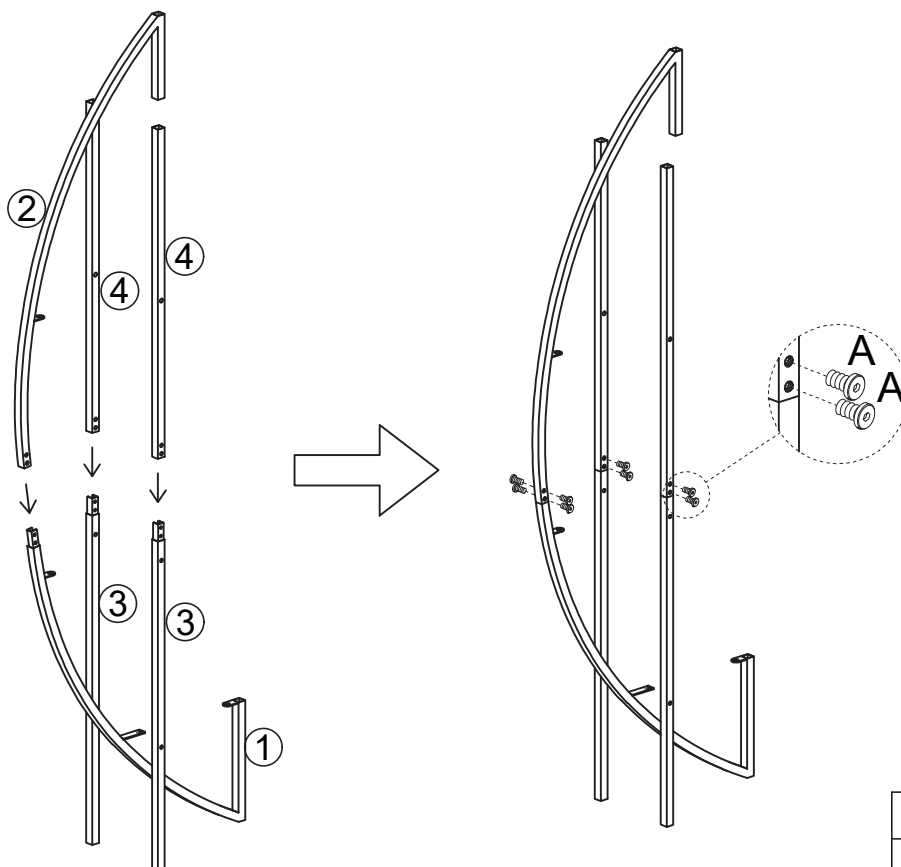

A	X16
	
M6*8mm	

STEP 2

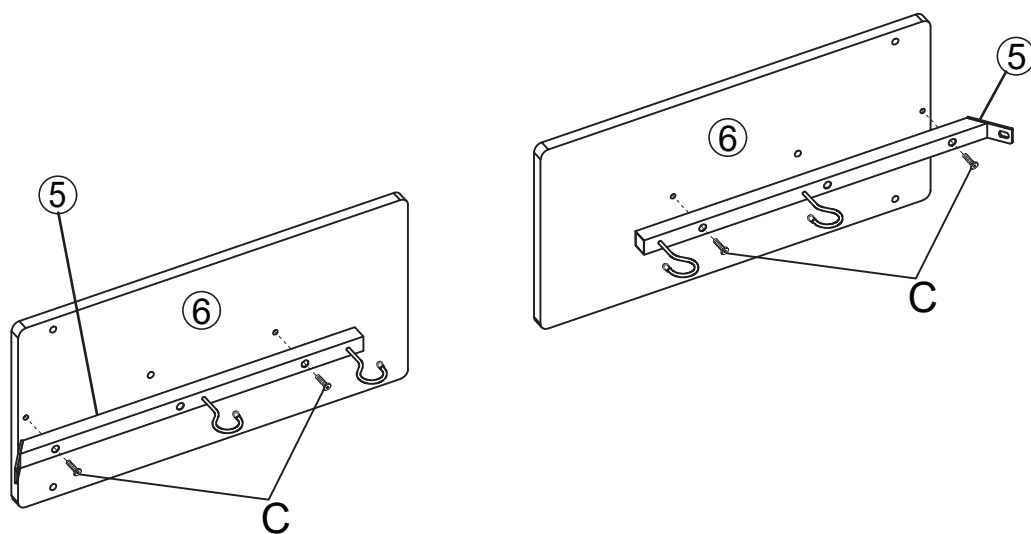



Use screws C x2 to attach each Part #5 to each Part #6 as shown , please do not tighten the screws

C	X4
	
M6*30mm	

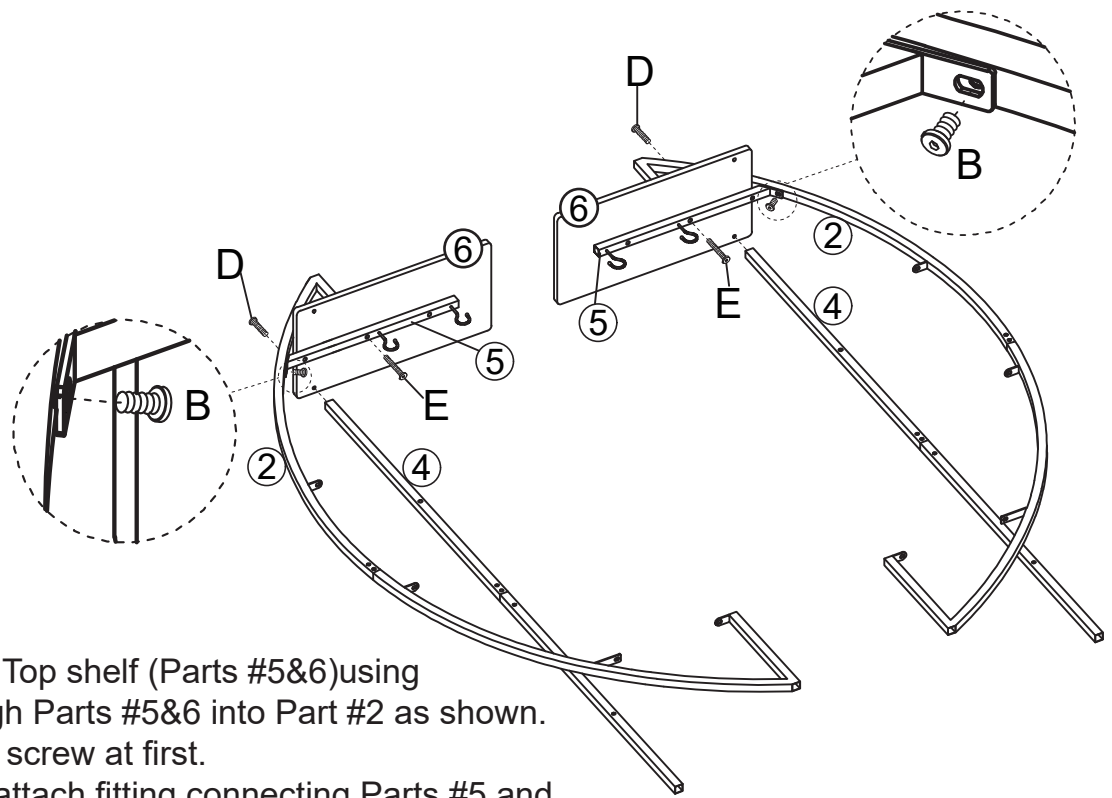
STEP 3



First, attach Part #2 to Top shelf (Parts #5&6) using screw E to pass through Parts #5&6 into Part #2 as shown. Do not fully tighten the screw at first. Then, use Screw B to attach fitting connecting Parts #5 and Part #2, and tighten all the screws from the previous steps. Finally, Attach Part #4 to Parts #6 using screw D as shown. Please do not fully tighten Screw D

B	X2	D	X2	E	X2
					
M6*12mm		M6*40mm		M6*55mm	

STEP 4

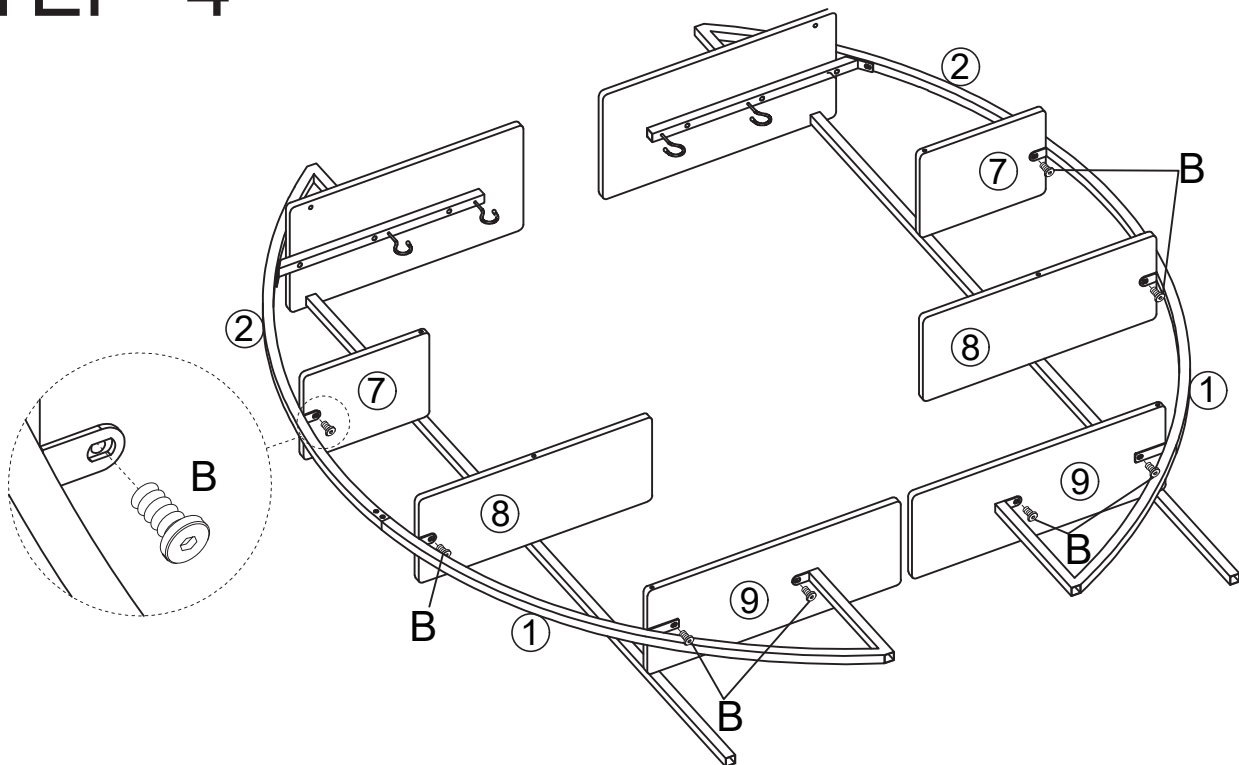

Attach Shelf Parts #7 , #8, #9 to Parts #1 & Part #2 using Screws B as shown. Then tighten Screw D from Step 3.

B	X8
	
M6*12mm	

STEP 5

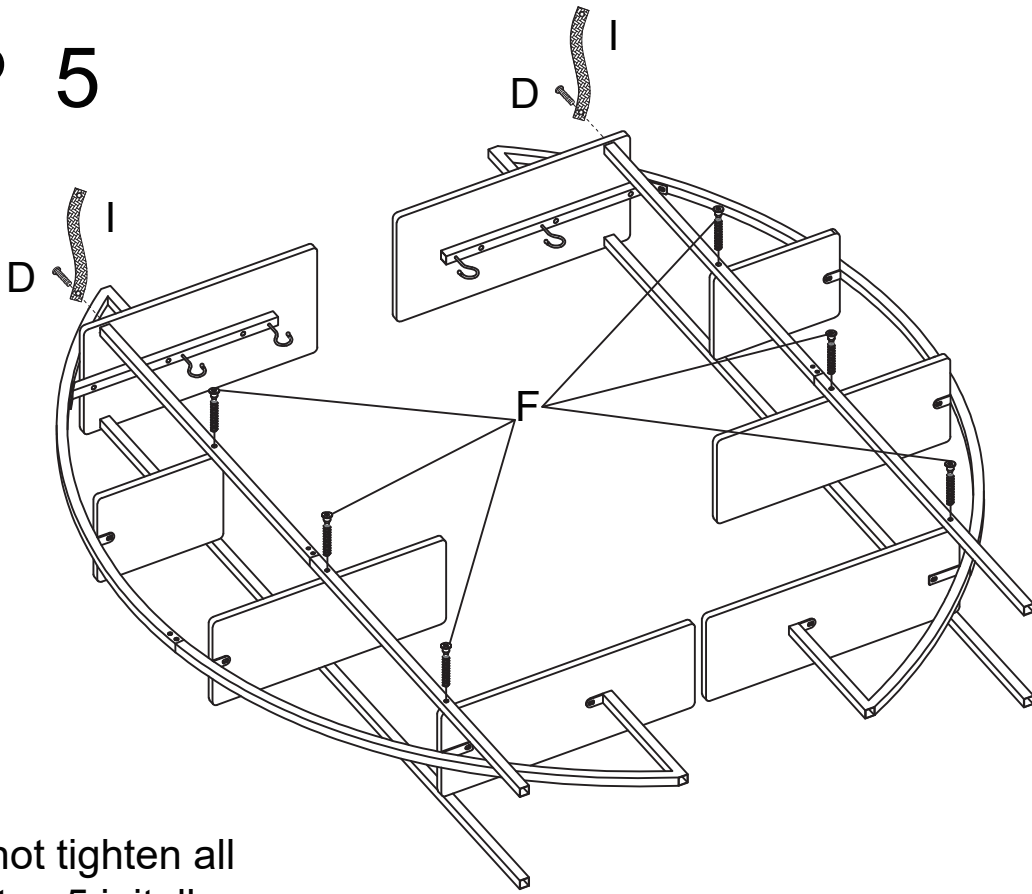

Please do not tighten all screws in step 5 initially. Tighten the screws after completing step 7.

D	X2	F	X6	I	X2
M6*40mm		Φ7*47mm		180*25mm	

STEP 6

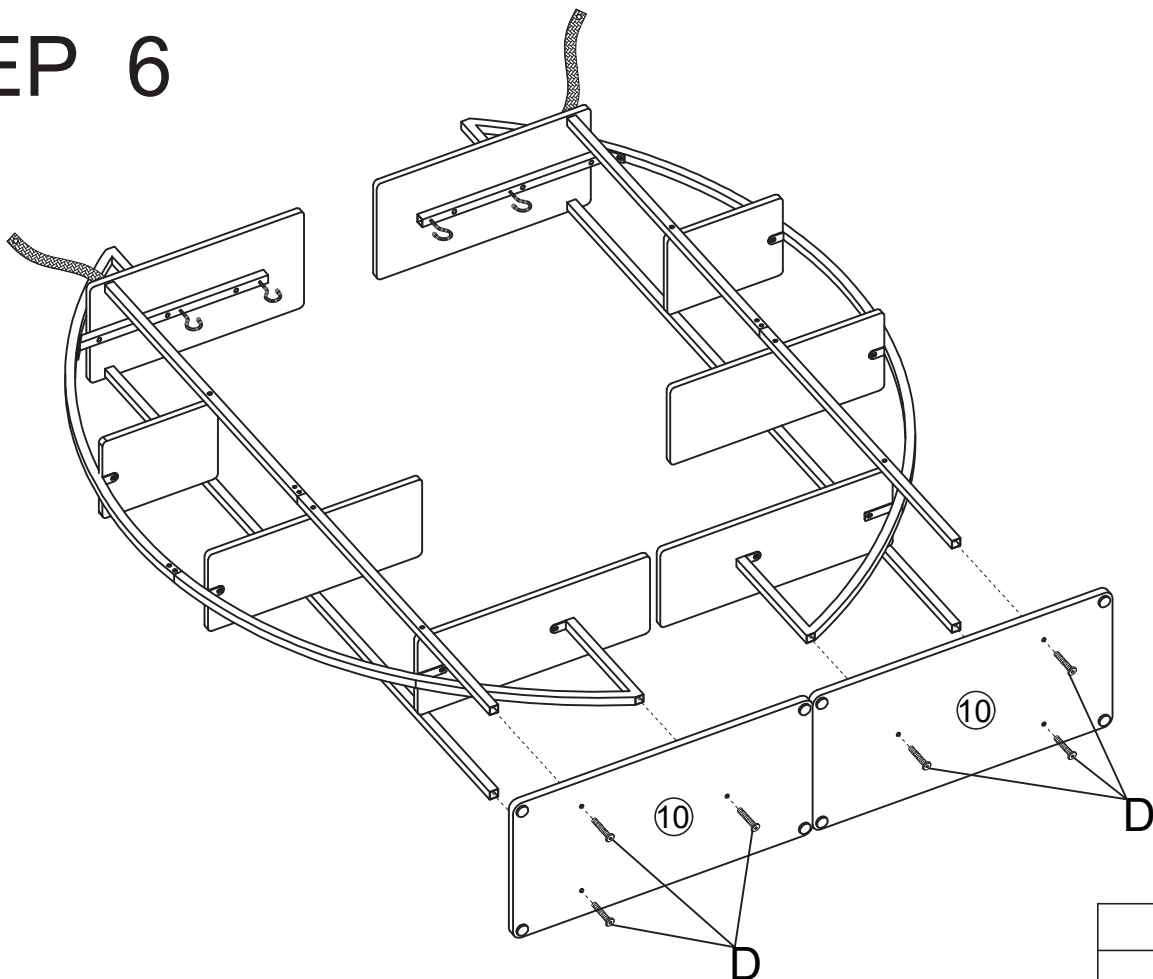

D	X6
M6*40mm	



STEP 7

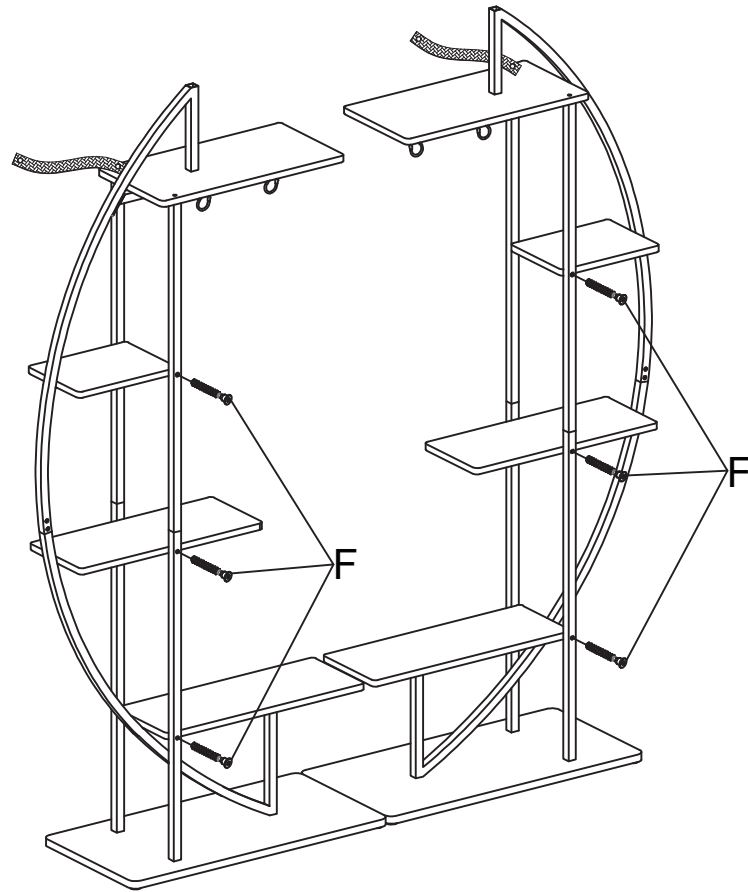

Tighten screws F x6 as shown.
Then tighten screws F x6 opposite side from step 5.

F	X6
Φ7*47mm	

STEP 8

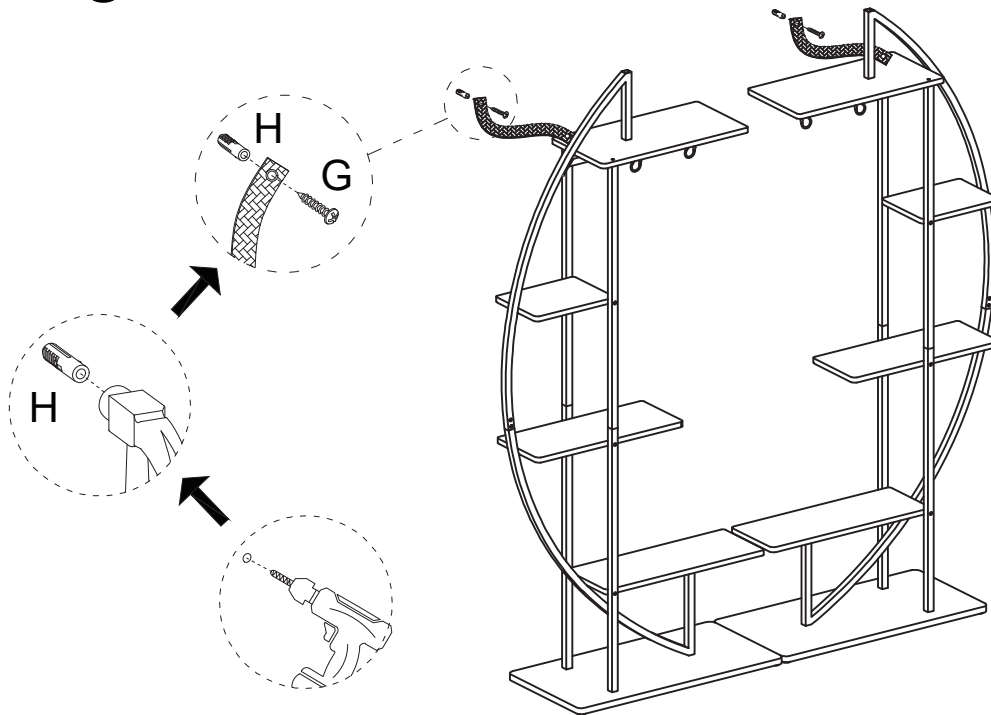

IMPORTANT: Attach Safety Straps to avoid stand tipping accidents. Place strap (Part I) around the back vertical support near the top. Use Screw (PART G) with Anchor (PART H) to attach securely to the wall.

G	X2	H	X2
4*35mm		Φ6*30mm	