

ASSEMBLY INSTRUCTIONS

TWIN OVER TWIN BUNKBED

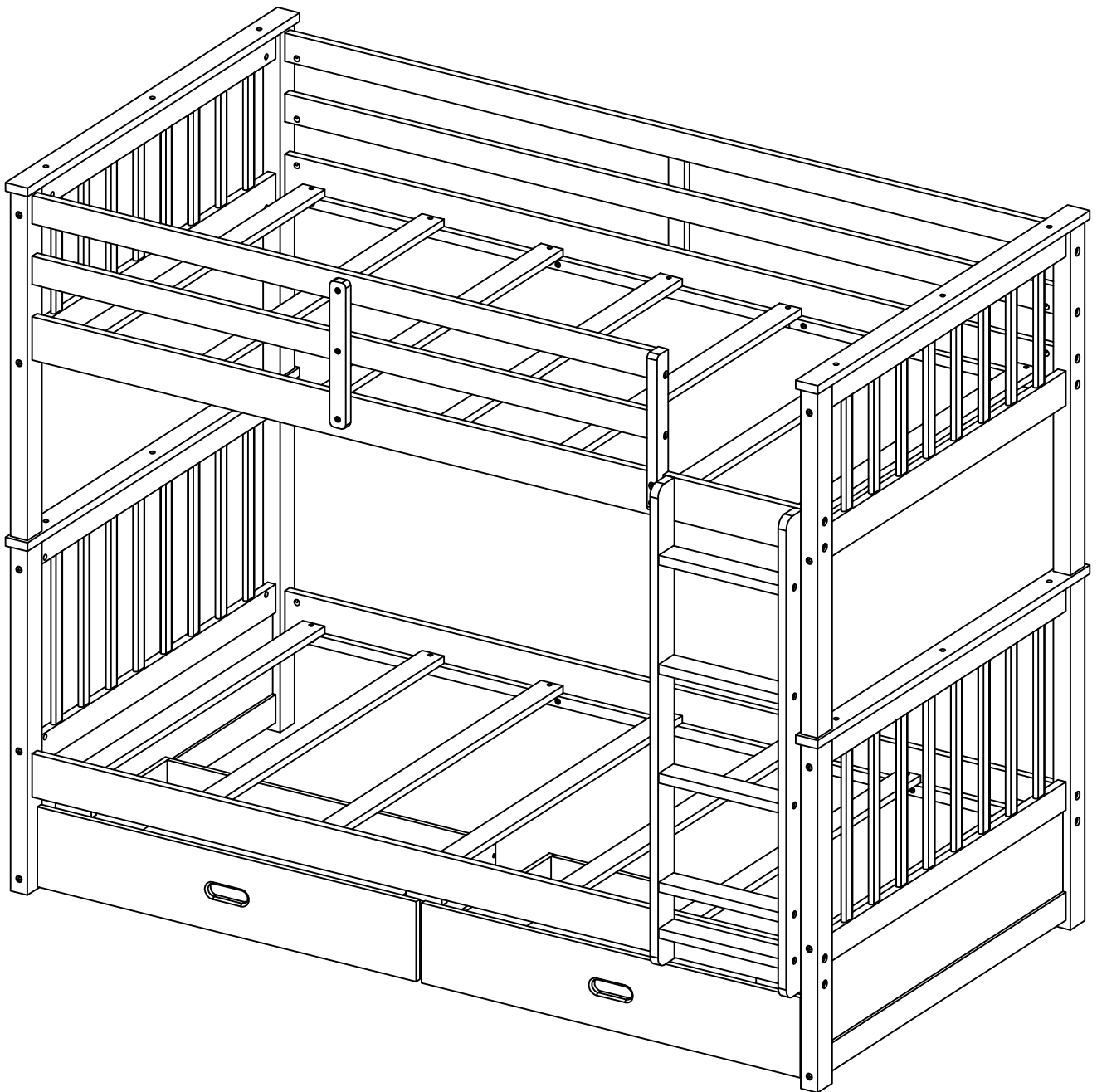

! SAFETY WARNINGS !

1. This bed is designed for use only mattress(es) meeting the following specifications on the upper bunk, and lower bunk:

Upper bunk(bunk bed and tribed included)



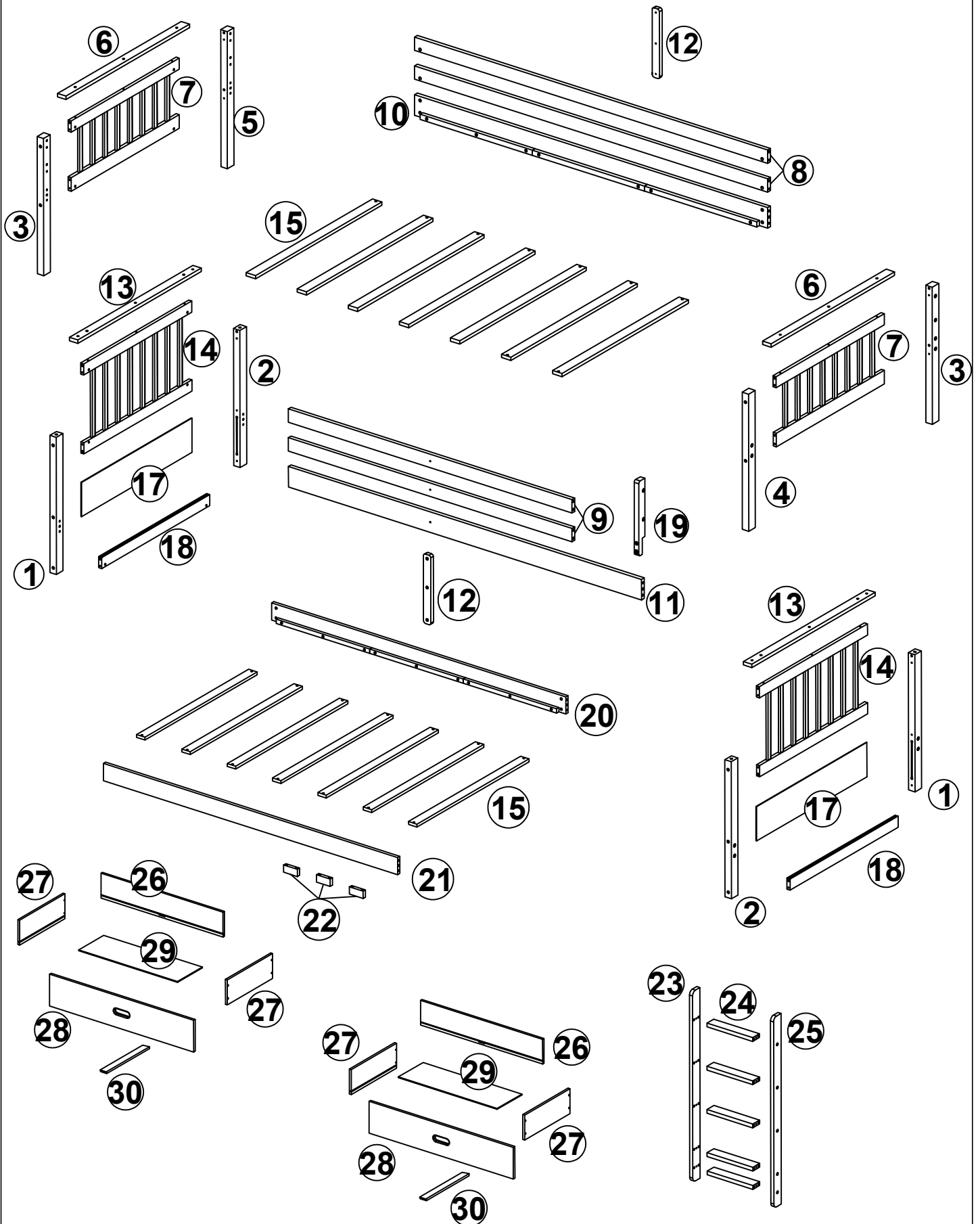

Bed type	Length	Width	Thickness
Twin Standard	74" - 75"	38 1/2"	6"

2. Replacement parts, including additional guardrails, may be obtained from any of our dealers.
3. Follow the information on the warnings appearing on the upper bunk bed end structure and on the carton. Do not remove warning label from bed.
4. Always use the recommended size mattresses or mattress supports, or both, to help prevent the likelihood of entrapment or falls.
5. Surface of the mattress must be at least 5 in. (127 mm) below the upper edge of guardrails.
6. Do not allow children under 6 years of age to use the upper bunk.
7. Periodically check and ensure that the guardrail, ladder, and other components are in their proper position, free from damage, and that all connectors are tight.
8. Do not allow horseplay on or under the bed and prohibit jumping on the bed
9. Always use the ladder for entering and leaving the upper bunk.
10. Do not use substitute parts. Contact the manufacturer or dealer for replacement parts.
11. Use of a night light may provided added safety precaution for a child using the upper bunk.
12. Always use guardrails on both long sides of the upper bunk. If the bunk bed will be placed next to the wall, the guardrail that runs the full length of the bed should be placed against the wall to prevent entrapment between the bed and wall.
13. The use of water or sleep flotation mattresses is prohibited.
14. **STRANGULATION HAZARD** – Never attach or hang items to any part of the bunk bed that are not designed for use with the bed; for axample, but not limited, hook, belts and jump ropes.
15. Keep these instructions for future reference
16. Prohidit more than one person on upper bunk .
17. We recommend assembling your bunk bed on the shipping carton to protect your floor or carpet .
18. Be caertain all staples are out of the box before beginning assembly on the shipping carton .

Detail View

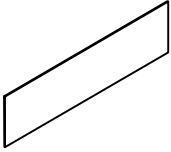
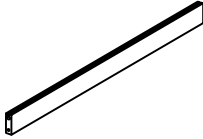

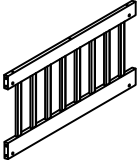
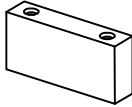
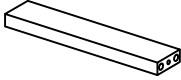
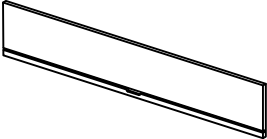
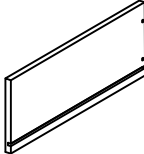
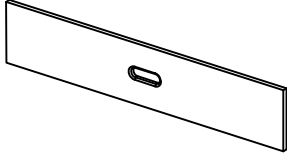
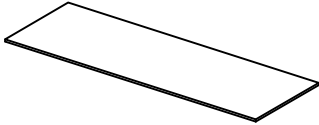
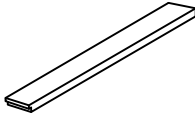

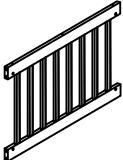
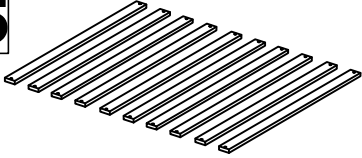



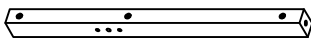
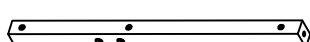
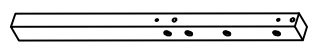
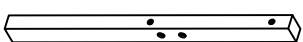
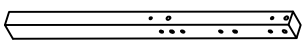
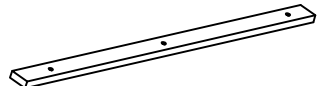
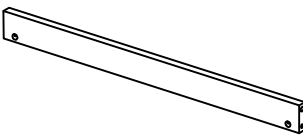
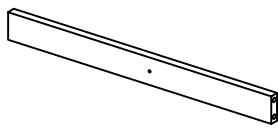
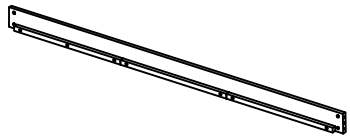
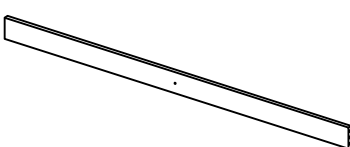
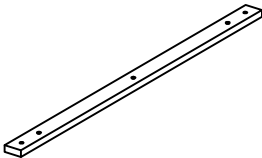
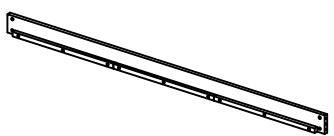
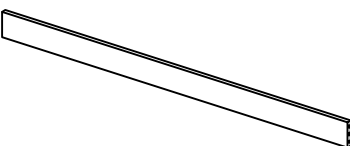
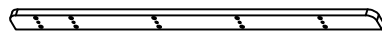
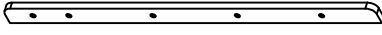

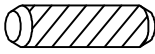
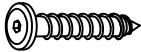

Part List :

17 	18 	19 
Side panel - 2pcs	Horizontal bar - 2pcs	Support guard rail - 1pc
7 	22 	24 
Upper HB & FB - 2pcs	Wood block - 3pcs	Step ladder - 5pcs
26 	27 	28 
Drawer back - 2pcs	Drawer (L/R) - 4pcs	Drawer front - 2pcs
29 	30 	12 
Drawer bottom - 2pcs	Center support drawer-2pcs	Vertical guard rail - 2pcs
14 	15 	
Lower HB/FB - 2pc	Slat - 14pcs	

Part List :

1 	2 	3 
Lower leg HB-FB (Left)-2pcs	Lower leg HB-FB (Right)-2pcs	Upper leg HB&FB (L/R)-2pcs
4 	5 	6 
Upper leg FB (Right)-1pc	Upper leg HB (Right)-1pc	Cap for upper HB&FB-2pcs
8 	9 	10 
Long guard rail-2pcs	Short guard rail-2pcs	Side rail upper (Back) -1pc
11 	13 	20 
Side rail upper (Front) -1pc	Cap for lower HB&FB-2pcs	Side rail lower (Back) -1pc
21 	23 	25 
Side rail lower (Front) -1pc	Ladder (Left) - 1pc	Ladder (Right) - 1pc

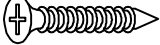
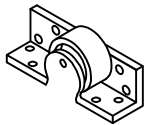
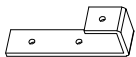
Hardware List :

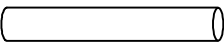
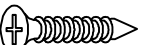
A  Ø10*30mm	B  Ø6*30mm	C  Ø6*50mm
Wood dowel (56pcs)	Hex-Head screw (6pcs)	Hex-Head screw (12pcs)
D  Ø1/4"*100mm	E  Ø1/4"*80mm	F  Ø1/4"*65mm
Hex-Head screw (20pcs)	Hex-Head bolt (22pcs)	Hex-Head bolt (12pcs)
G  Ø1/4"*30mm	H  Ø1/4"	J  Ø1/4"*9.5*12mm
Hex-Head bolt (2pcs)	Nut (2pcs)	Horizontal-Hole bolt (54pcs)
K  K4mm	L  #4*30mm	M  Ø35mm
Allen key (1pc)	Screw (50pcs)	Small Wheel (8pcs)
Q  Hook (4pcs)	R  90*17*2mm	P  #3.5*12mm
Hook (4pcs)	Foam stick (4pcs)	Screw (20pcs)
T  Ø10*90mm	U  #4*20mm	
Metal dowel (4pcs)	Screw (12pcs)	

Step 1:

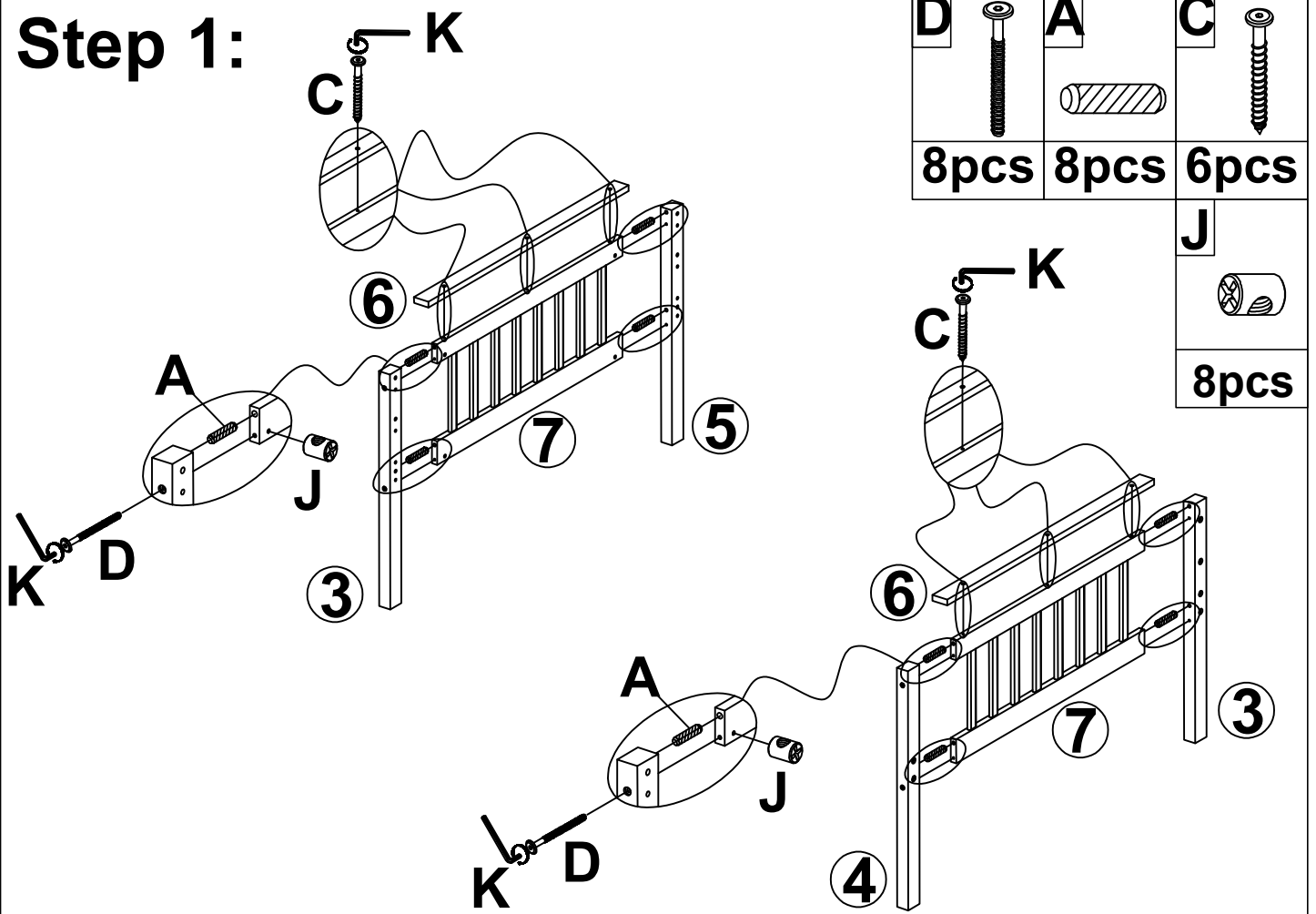

Step 2:

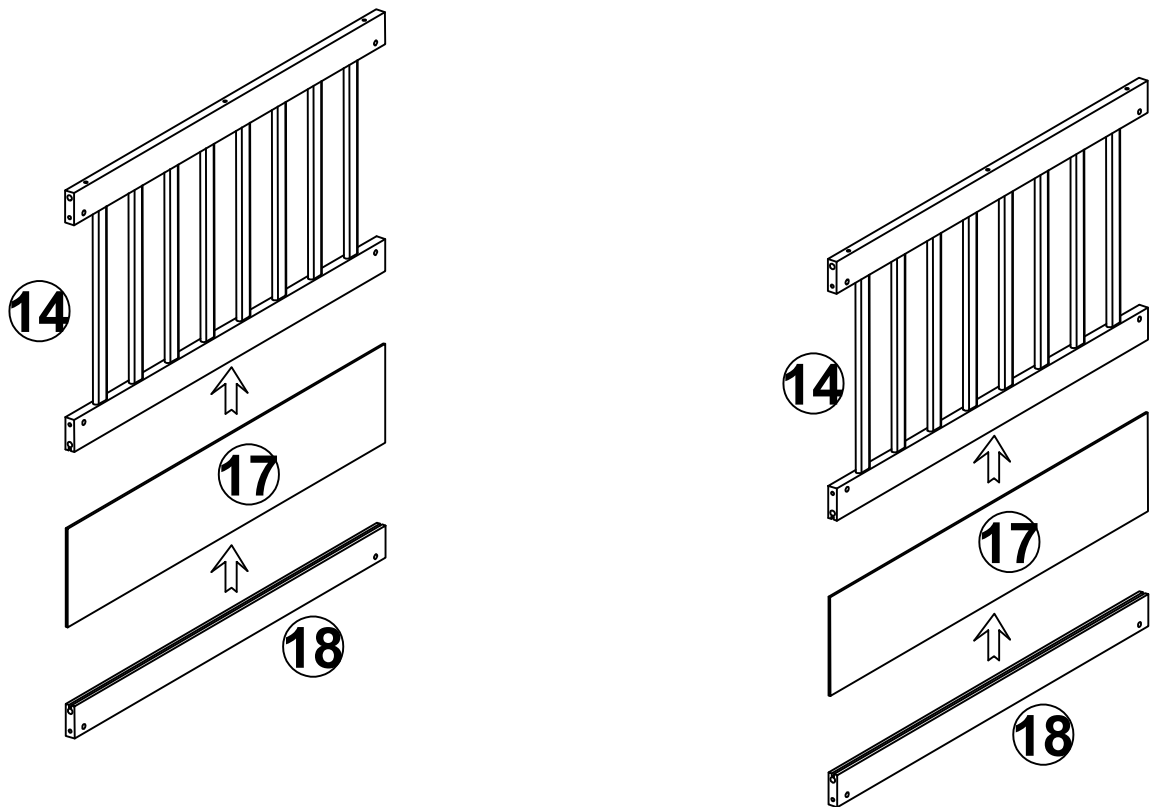

Step 3:

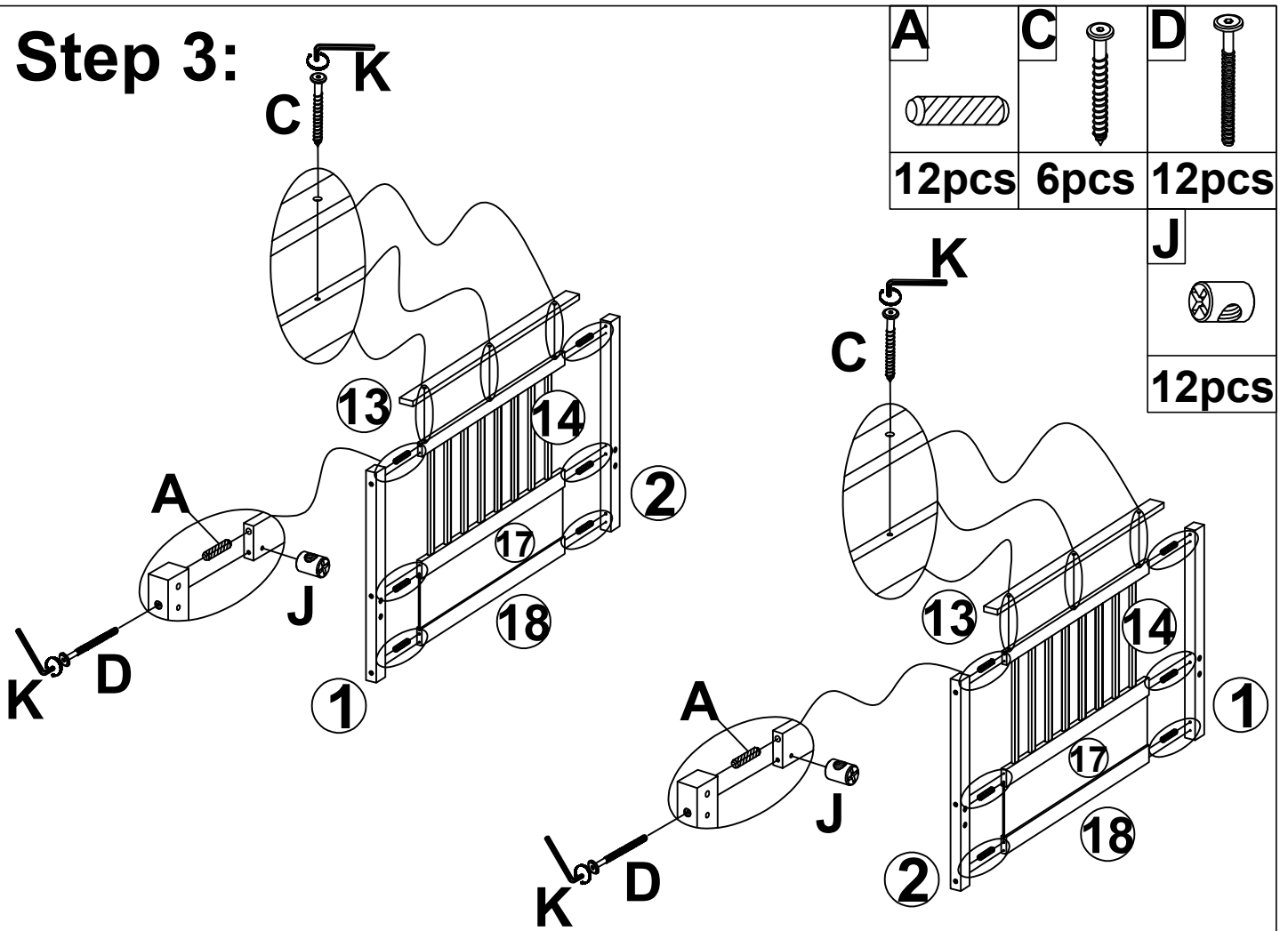

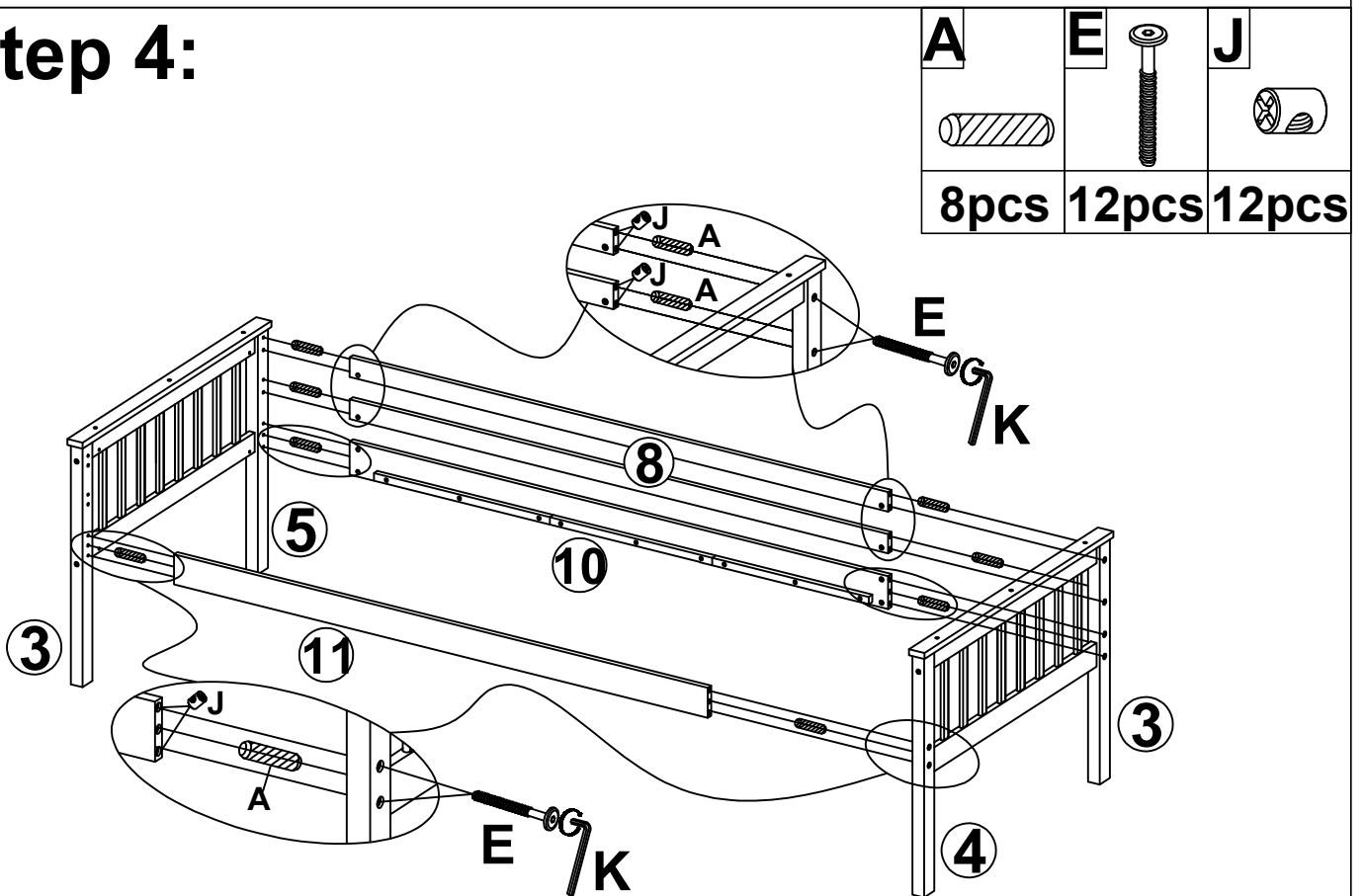

Step 4:





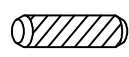

ATTENTION: PLEASE DON'T TIGHTEN ALL BOLTS IN THIS STEP, JUST TIGHTEN 80%

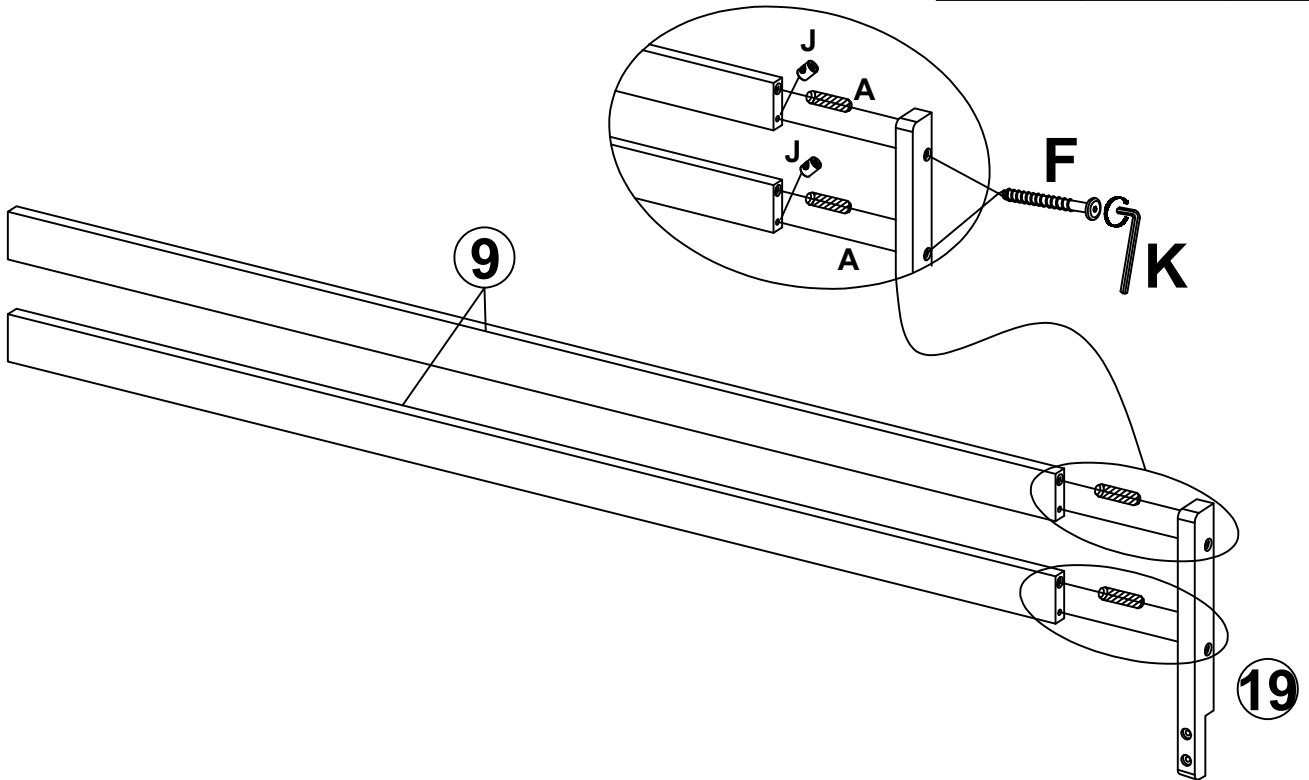
Step 5:

J	A	F	
			
2pcs	2pcs	2pcs	

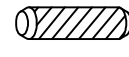

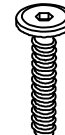
Step 6:

A	E	
		
2pcs	2pcs	
G	H	
		
2pcs	2pcs	
	J	
		2pcs

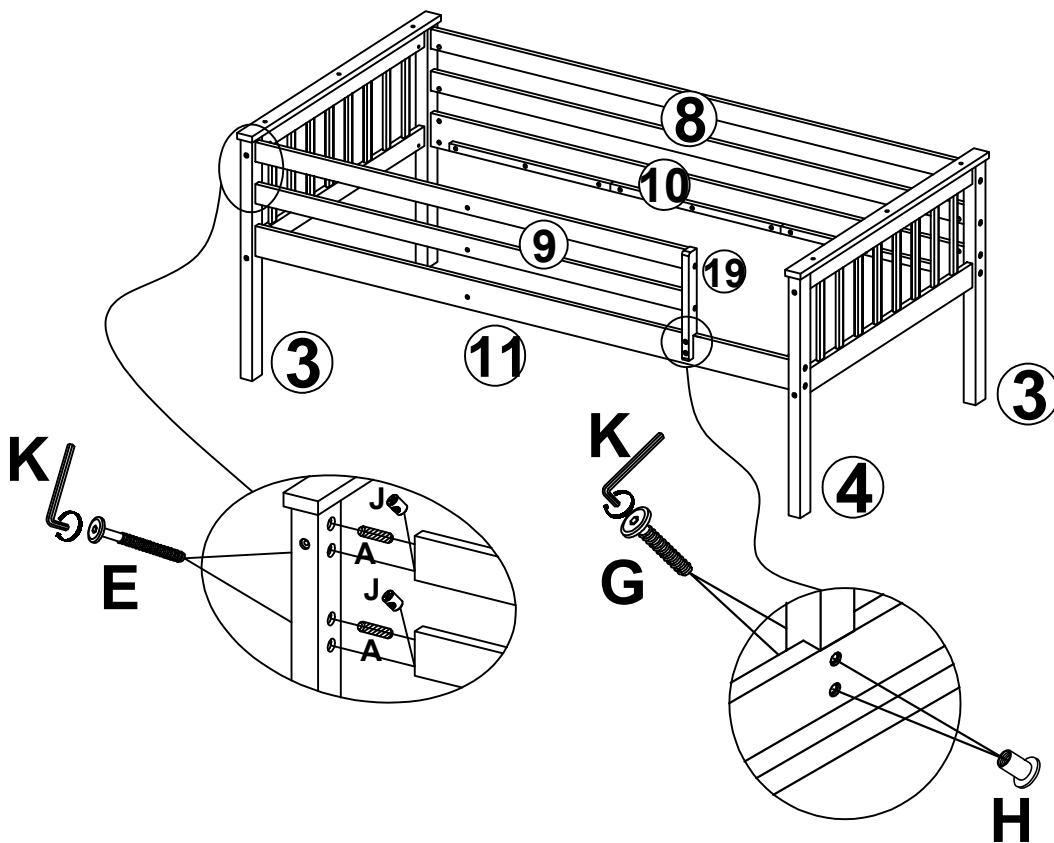

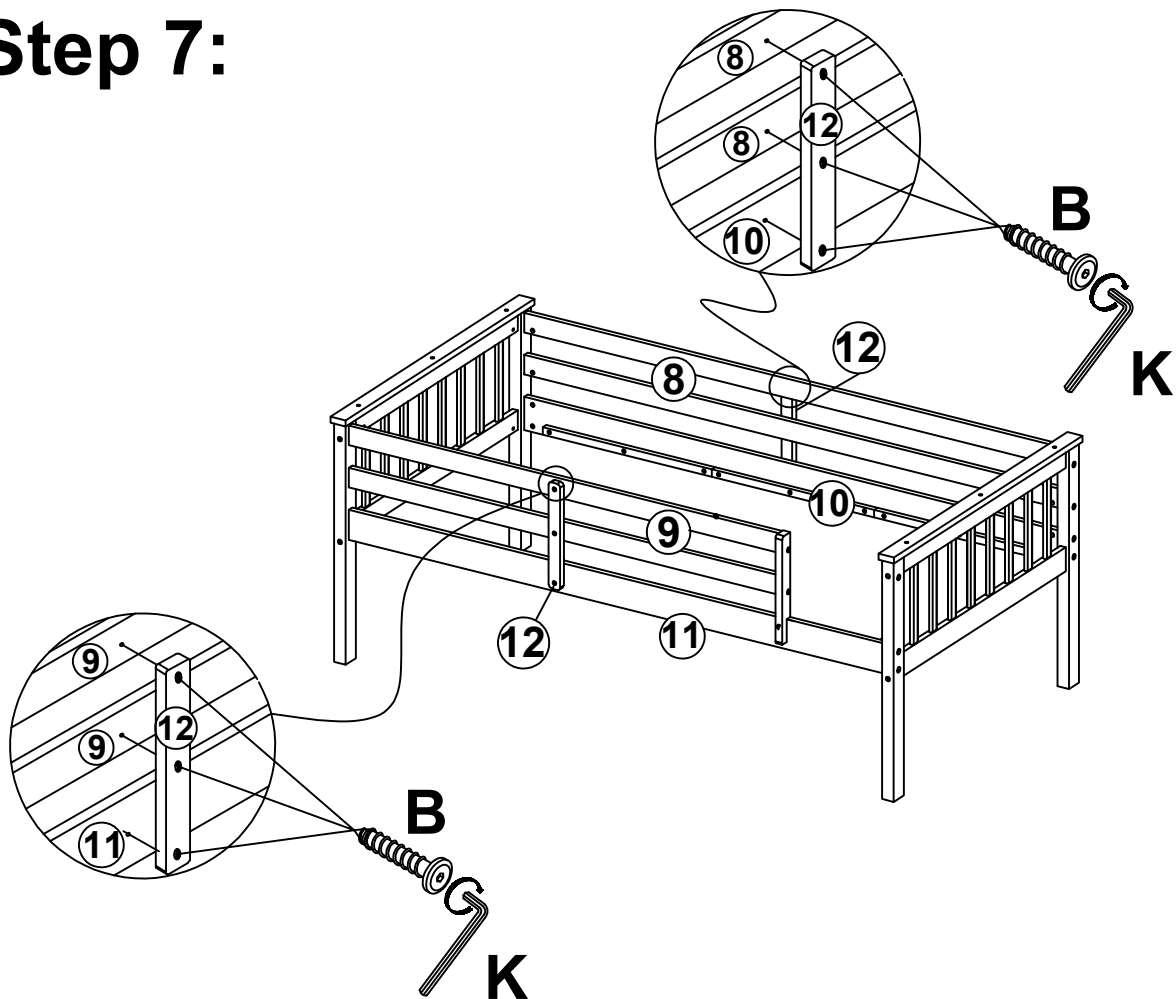

Step 7:

B	
6pcs	

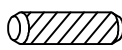

Step 8:

A	E	J
		
4pcs	8pcs	8pcs

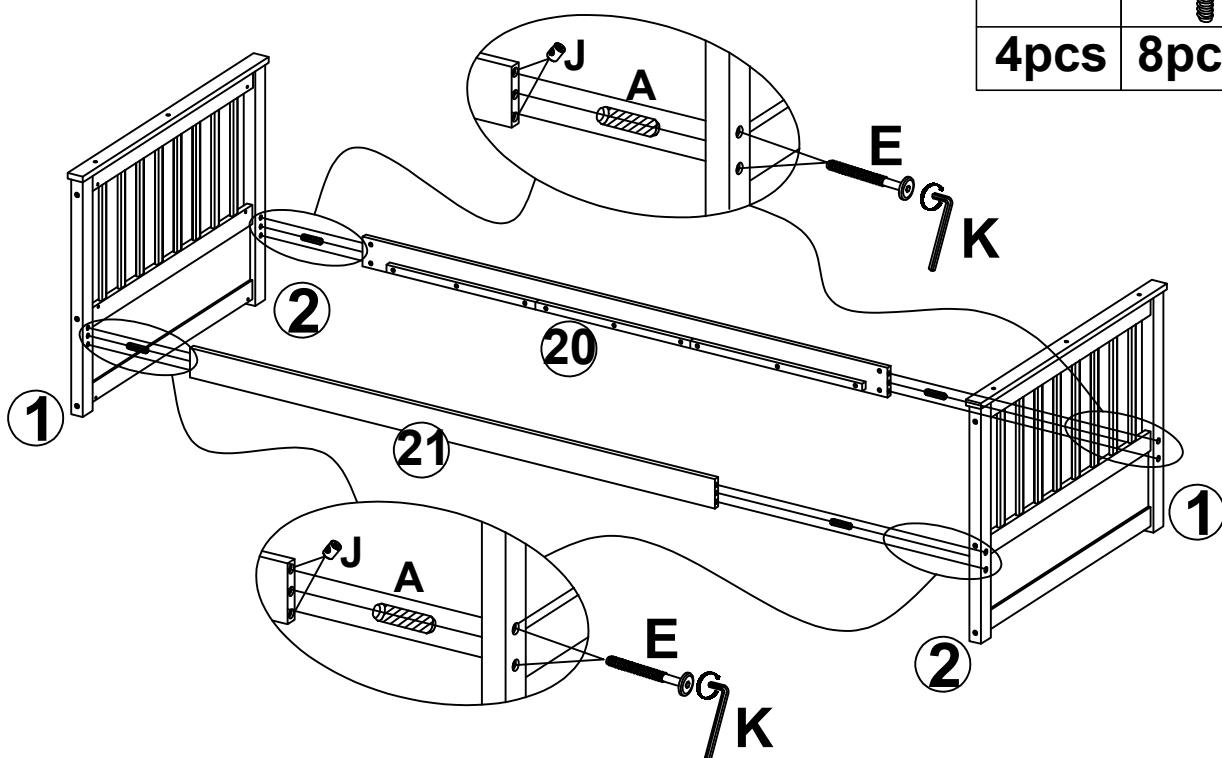

ATTENTION: PLEASE DON'T TIGHTEN ALL BOLTS IN THIS STEP, JUST TIGHTEN 80%

Step 9:

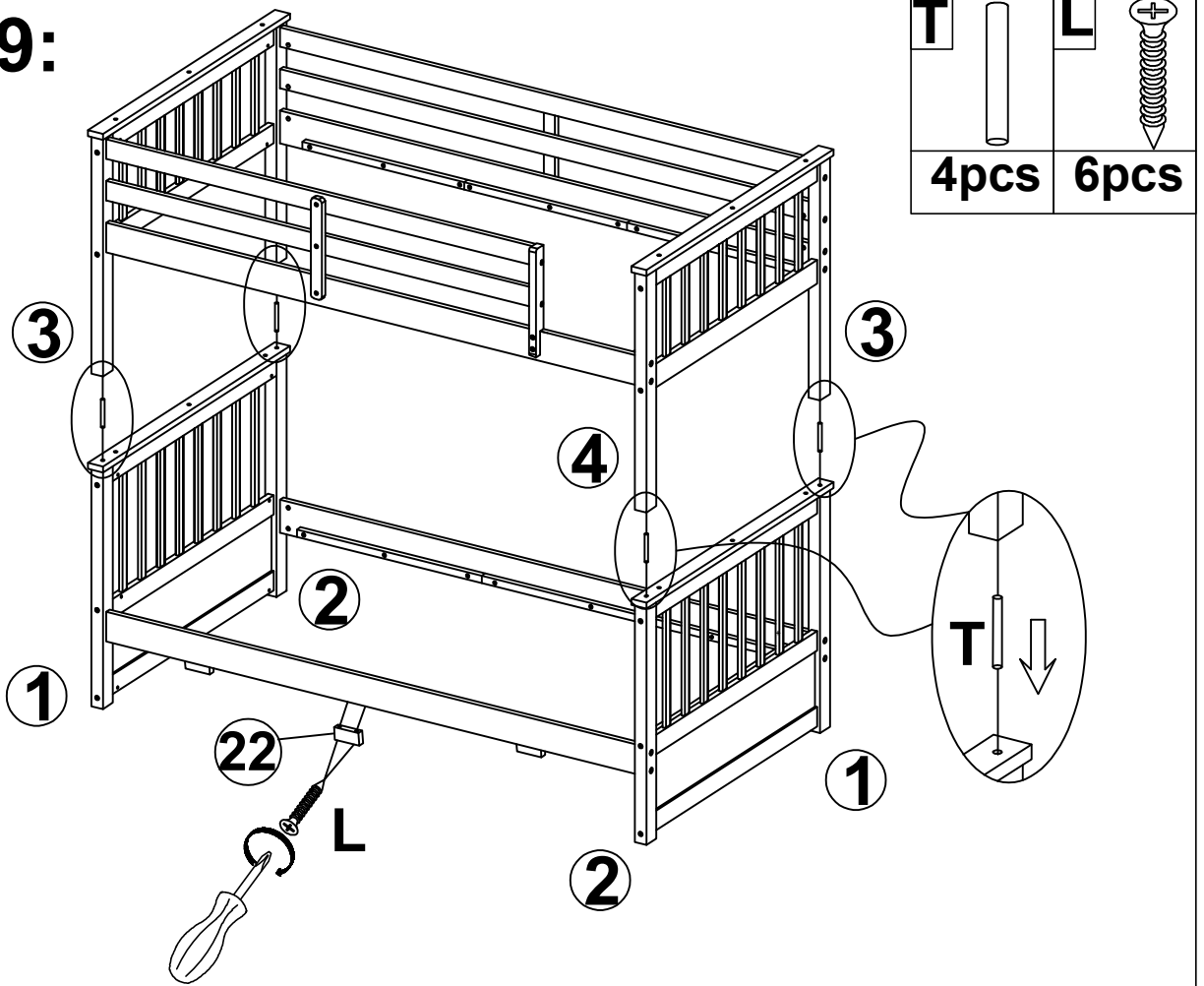

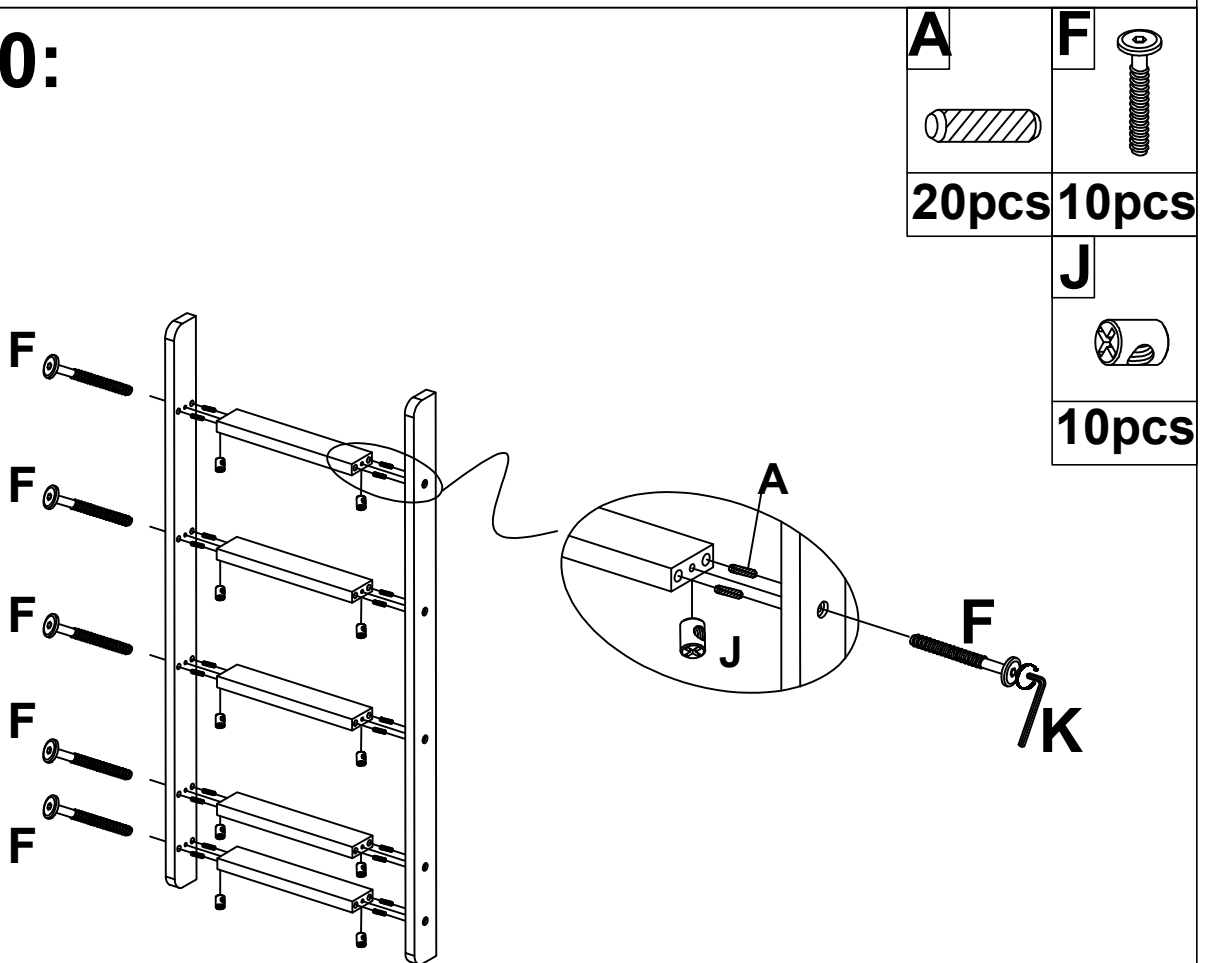

Step 10:



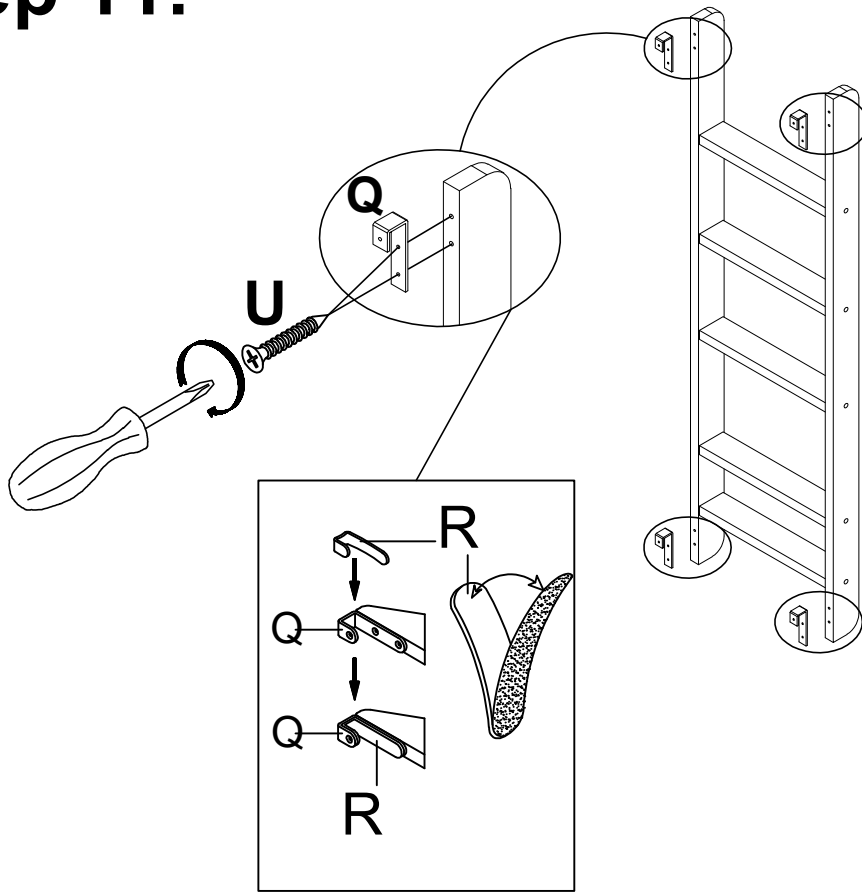

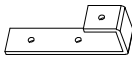
Step 11:

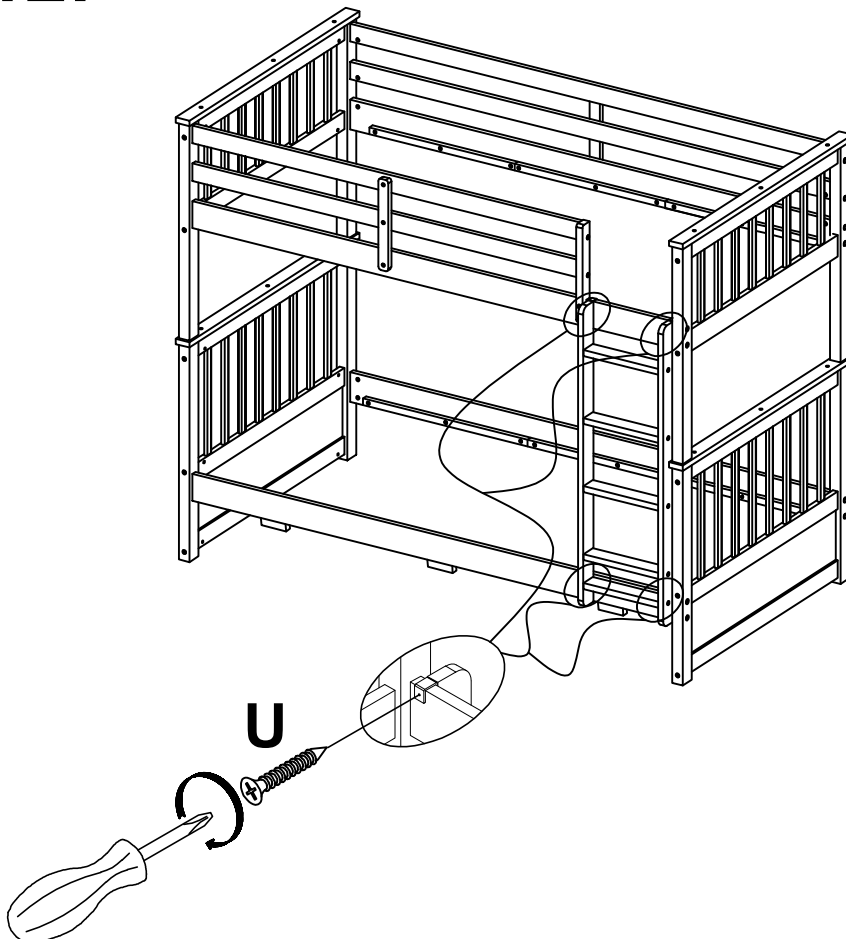

Q 	U 
4pcs	8pcs
	R 
	4pcs

Step 12:



U 
4pcs

Step 13:

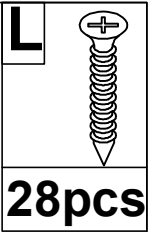

STEP 2: SCREW ALL SLATS

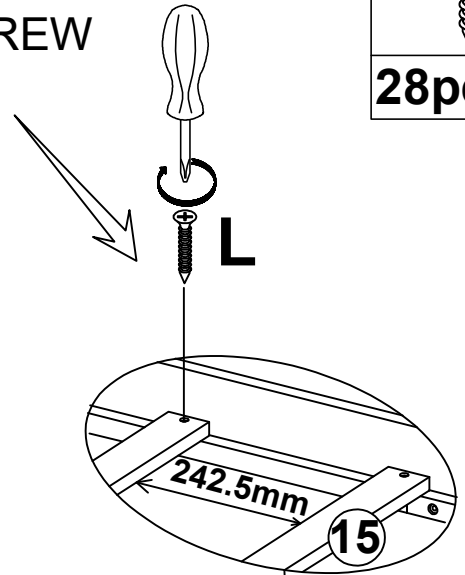

STEP 1: PULL SIDE RAIL CLOSE TOGETHER ENOUGH TO FIT THE SLATS

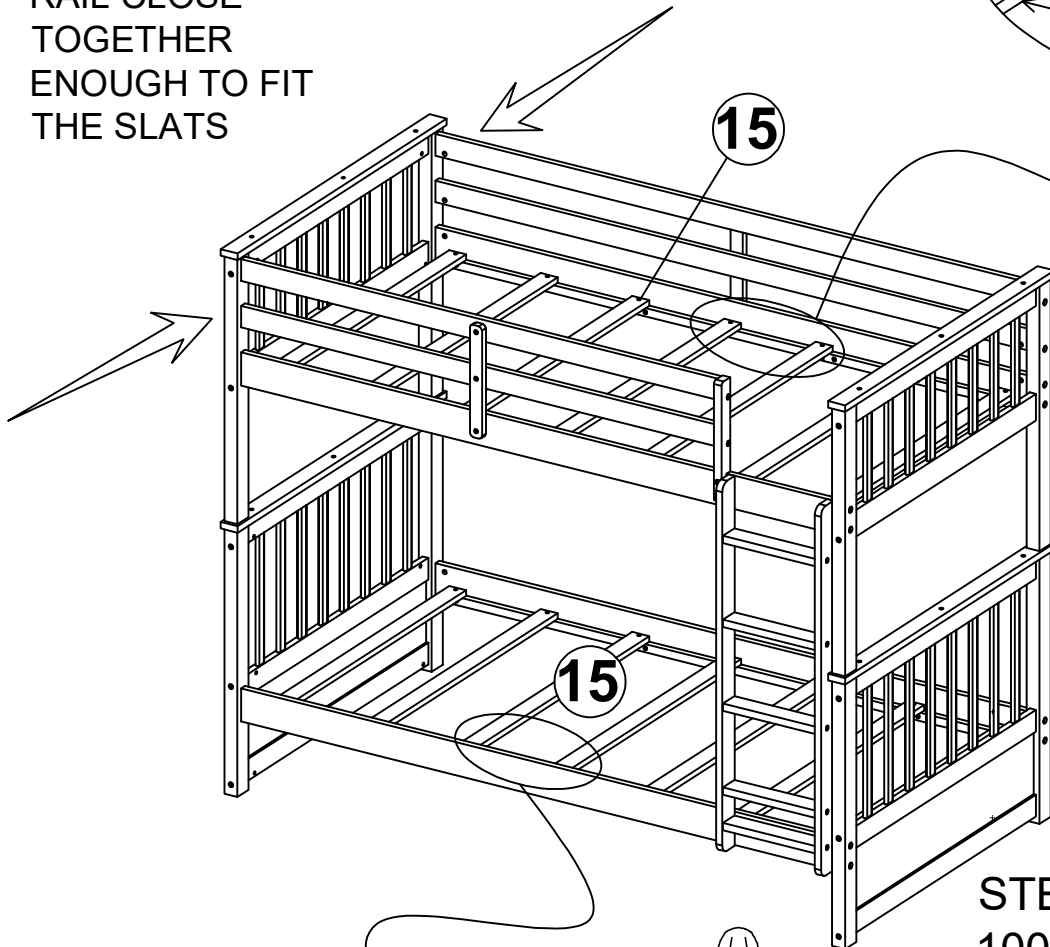

STEP 3: TIGHTEN 100% ALL HEXAGON BOLTS

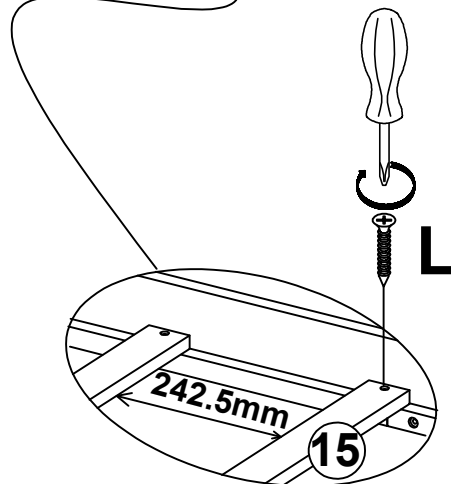

Step 14:

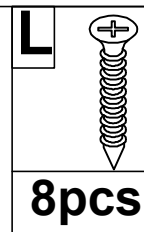
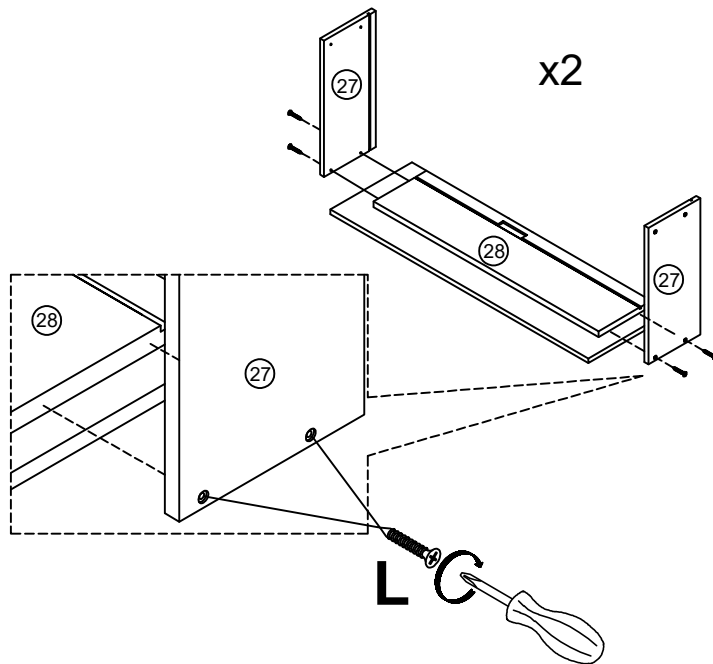

Step 15:

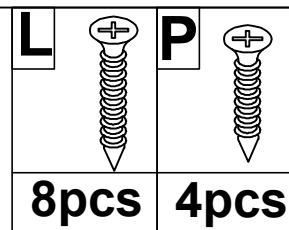
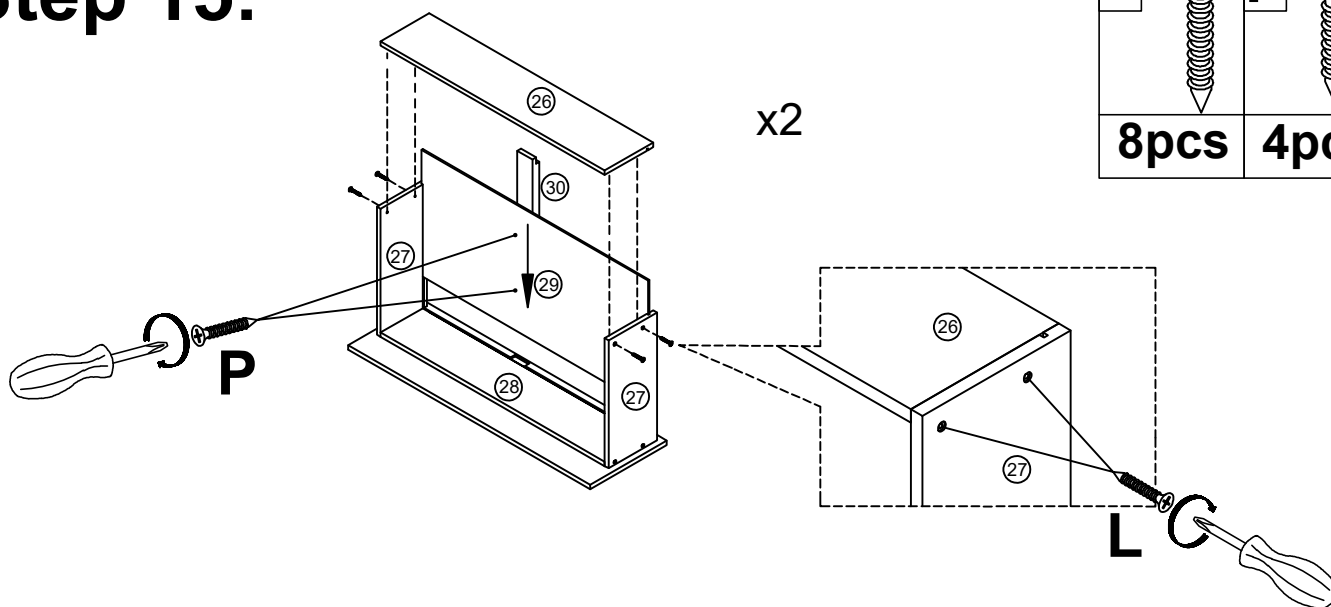

Step 16:

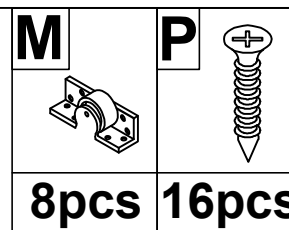
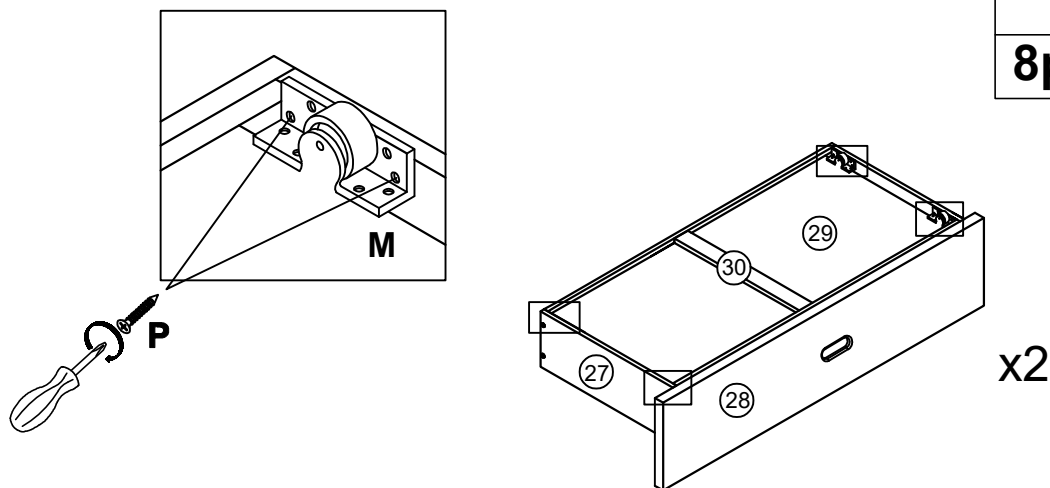

Step 17:

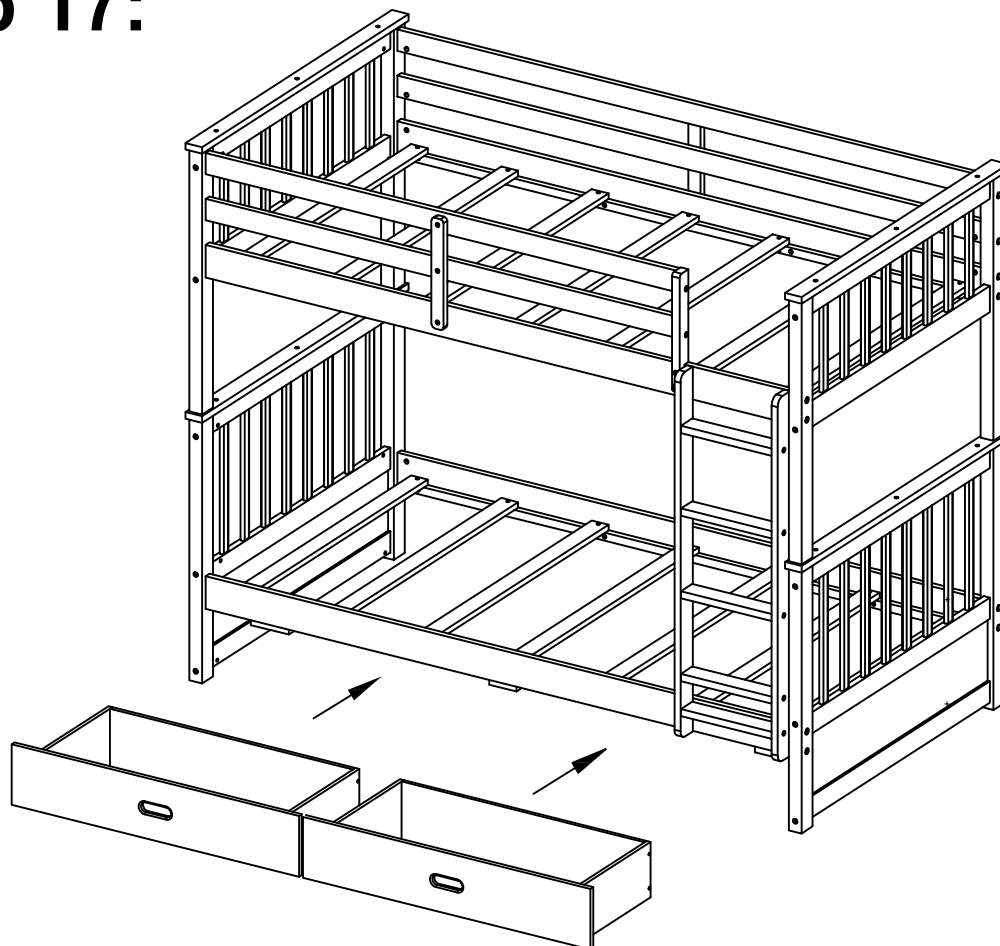

COMPLETED

