

PLATFORM TWIN BED

ASSEMBLY INSTRUCTIONS

PARTS AND FITTINGS PACKING DETAIL

BOX #1

A. HEADBOARD/FOOTBOARD 2PCS

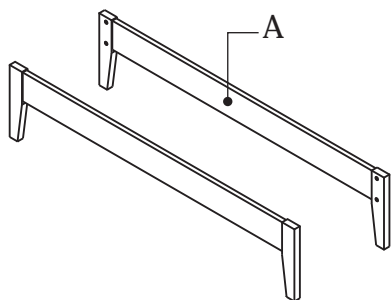

BOX #2

B. SIDERAILS 2 PCS

C. CENTER SLAT 1 PC

D. CENTER LEGS 4 PCS

HARDWARE BOX

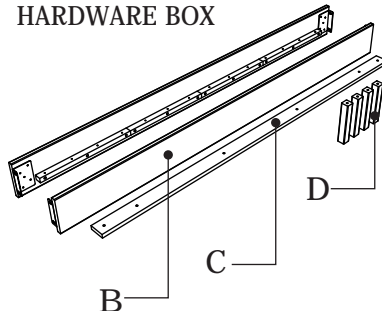

BOX #3

E. BED SLATS 12 PCS

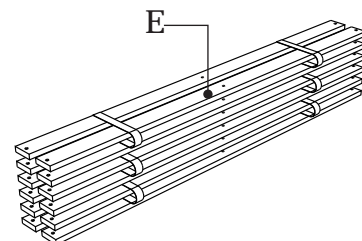

PLATFORM BED ASSEMBLY

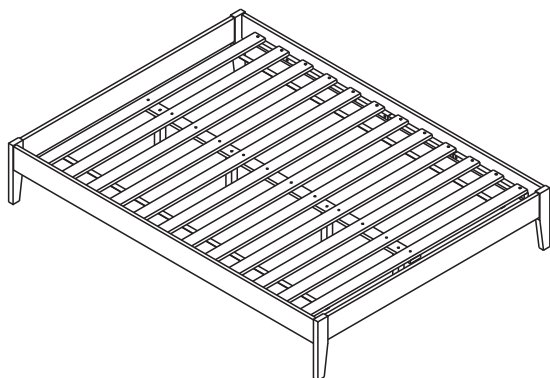

HARDWARE PACKED IN BOX #2

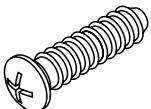
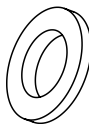
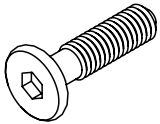
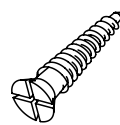
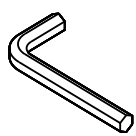
1	PHILLIPS HEAD BOLT 20MM	8 PCS	2	WASHER 8 MM	8 PCS	3	ALLEN BOLT 40 MM	10 PCS
								
4	WOOD SCREW 8x30MM	12 PCS	5	ALLEN KEY	1 PC			
								

TOOLS REQUIRED :
PHILLIPS HEAD SCREWDRIVER
(NOT PROVIDED)

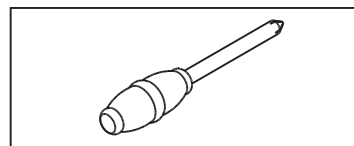

STEP 1 :

FIX ONE OF THE SIDERAILS (B) TO ONE OF HEADBOARD/FOOTBOARD (A) USING PHILLIPS HEAD BOLT (1) AND WASHERS (2).

DO NOT TIGHTEN BOLTS COMPLETELY UNTIL ASSEMBLY IS COMPLETED.

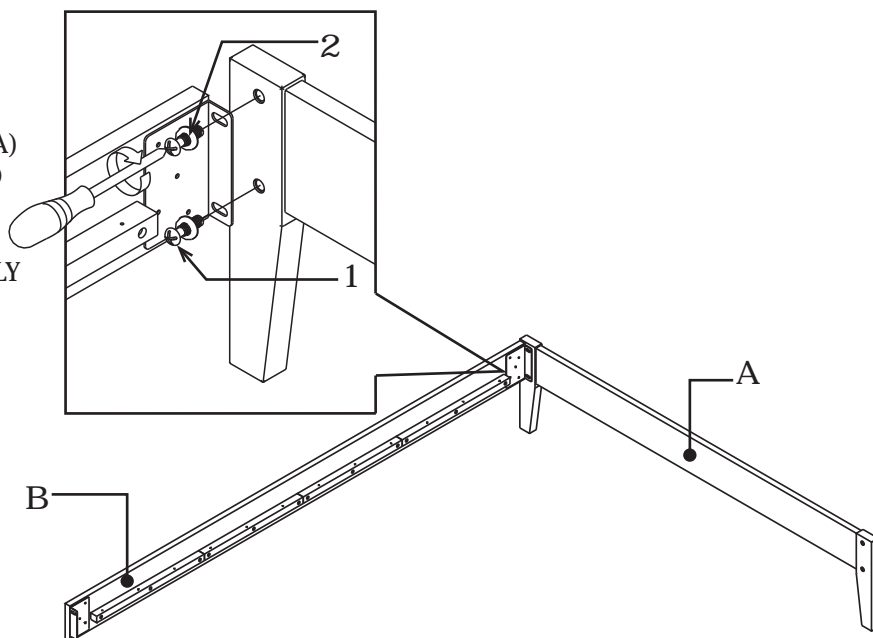

STEP 2 :

FIX THE OTHER END OF THE SIDERAILS (B) TO ONE OF THE HEADBOARD/FOOTBOARD (A) USING PHILLIPS HEAD BOLT (1) AND WASHERS (2).

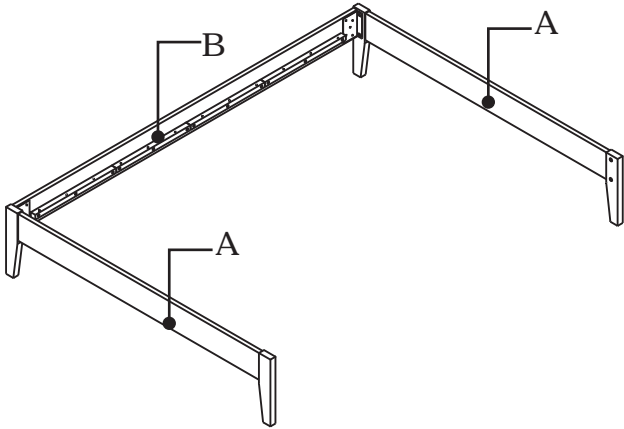

STEP 3 :

FIX THE OTHER SIDERAILS (B) TO THE HEADBOARD/FOOTBOARD (A).

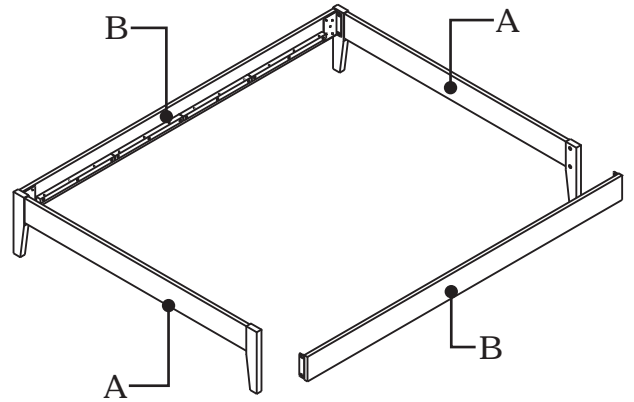

STEP 4 :

FIX CENTER LEGS (D) TO CENTER SLAT (C) USING ALLEN BOLTS (3). SLIDE IN ALLEN BOLTS (3) TO PREDRILLED HOLES THAT DON'T HAVE A T-NUT IN IT ON THE CENTER SLAT (C). MAKE SURE THE T-NUT IS FACING THE FLOOR.

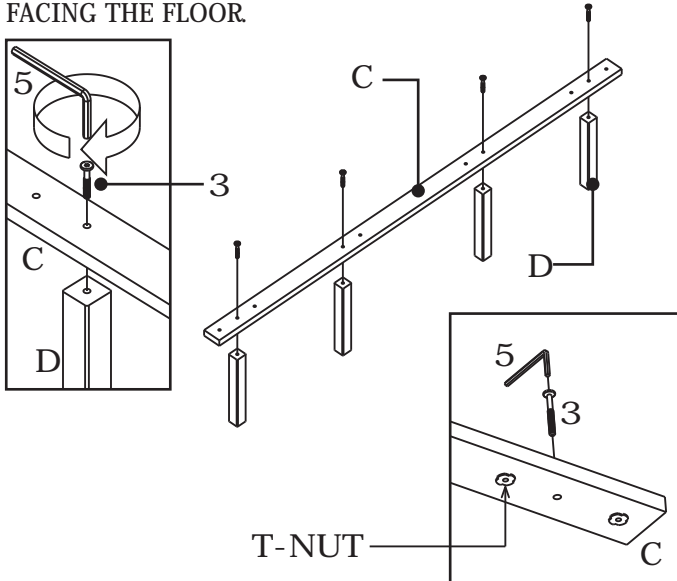

STEP 5 :

FOLLOW THE ILLUSTRATION TO SPREAD OUT ALL THE BED SLATS (E) ON THE BED FRAME, AND FIX THE BED SLATS (E) USING WOOD SCREWS (4). USE THE PILOT HOLES ON THE SIDERAILS (B) AS YOUR REFERENCE, FOR EASY ASSEMBLY. YOU MAY NEED TO ADJUST THE SIDERAILS (B) POSITION TO LINE UP THE HOLES.

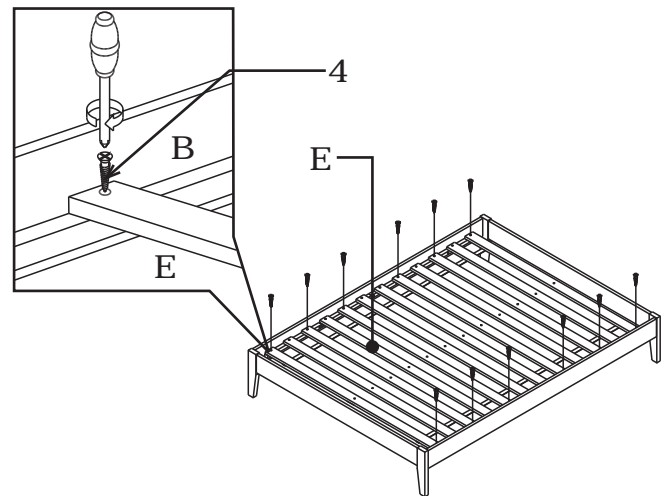

STEP 6 :

SLIDE IN THE CENTER SLAT (C) UNDER THE BED SLATS (E). USE THE 1ST, 2ND, 5TH, 8TH, 11TH AND 12TH PRE-DRILLED HOLES ON BED SLATS (E) FROM HEADBOARD/FOOTBOARD(A) SIDE. FIX THE CENTER SLAT (C) TO THE BED SLATS (E) BY SLIDING IN THE ALLEN BOLTS (3) THROUGH THE HOLES FROM THE TOP OF BED SLATS (E) TO THE CENTER SLAT (C).

TIGHTEN ALL BOLTS AND SCREWS BEFORE USAGE.

