

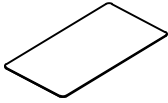

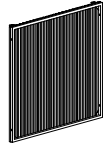



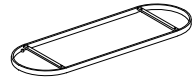

ASSEMBLY INSTRUCTIONS

PARTS LIST

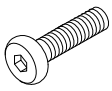
| | | | |
|---|---|--|---|
| A Table top  1 PC | B Wing Panel  2 PCS | C Pedestal  2 PCS | D Base Ring  1 PC |
|---|---|--|---|

HARDWARE LIST

| | | |
|--|---|---|
| 1  Bolt(1/4" x 7/8") 10PCS | 2  Bolt (1/4" x 1-1/4") 8PCS | 3  Spring Washer (1/4") 18 PCS |
| 4  Washer(1/4"xØ16) 18PCS | 5  Allen Wrench(4mm) 1PC | |

Step 1

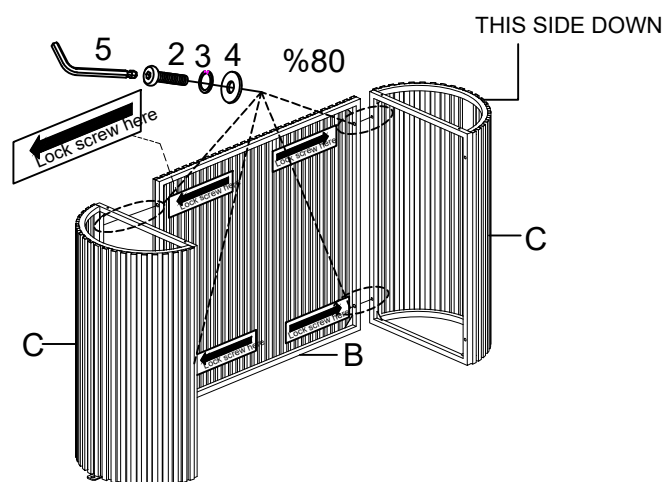

In this step, tighten the screws to 80%.
Note: Do not lock the screws.

ASSEMBLY INSTRUCTIONS

Step 2

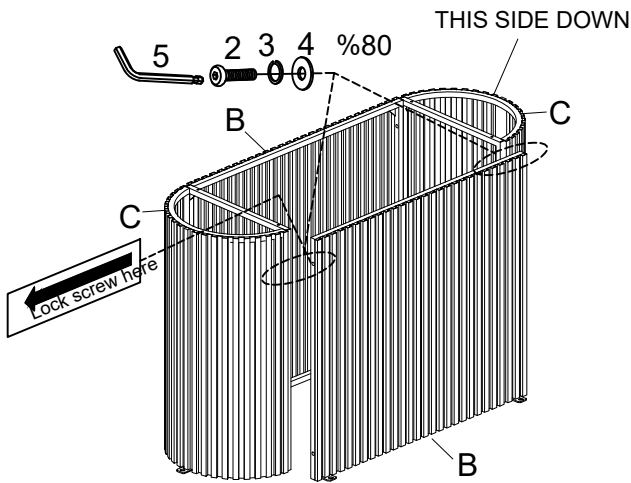

In this step, tighten the screws to 80%.
Note: Do not lock the screws.

Step 3

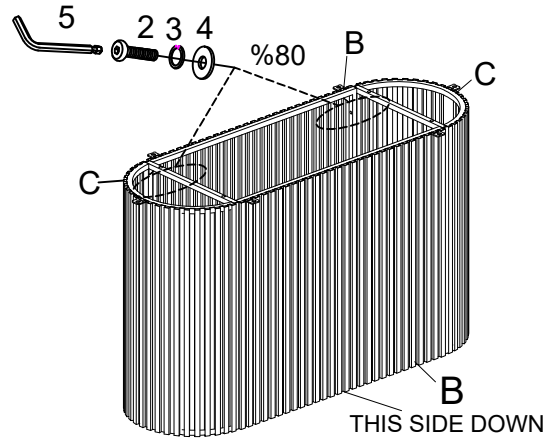

With the assistance of an adult partner, place the base upside down. Then, lock the Wing Panel (B) and Pedestal (C).
In this step, tighten the screws to 80%.
Note: Do not lock the screws.

Step 4

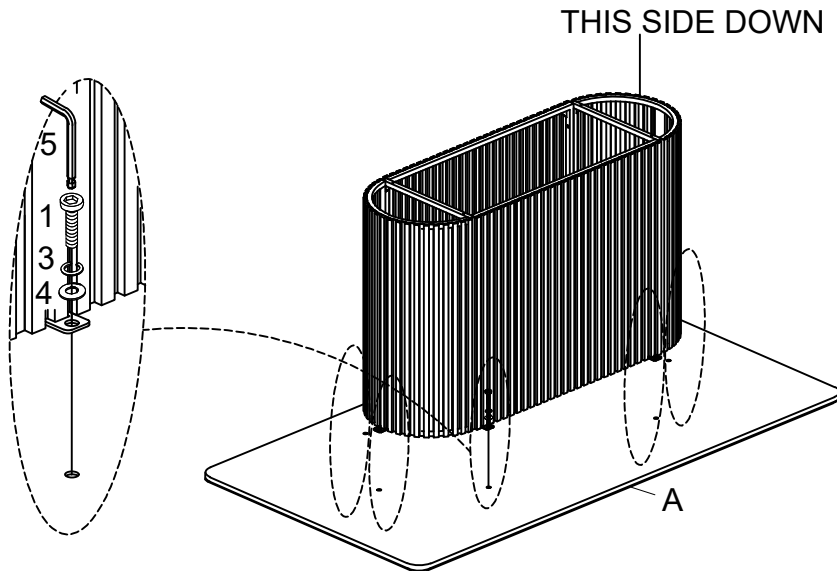

Place the tabletop facedown on a clean, non-marring surface. Attach the table base to the bottom of the tabletop using screws, as shown in the pictures.
Attention: When locking the tabletop, please use Short Bolt(1).

ASSEMBLY INSTRUCTIONS

Step 5

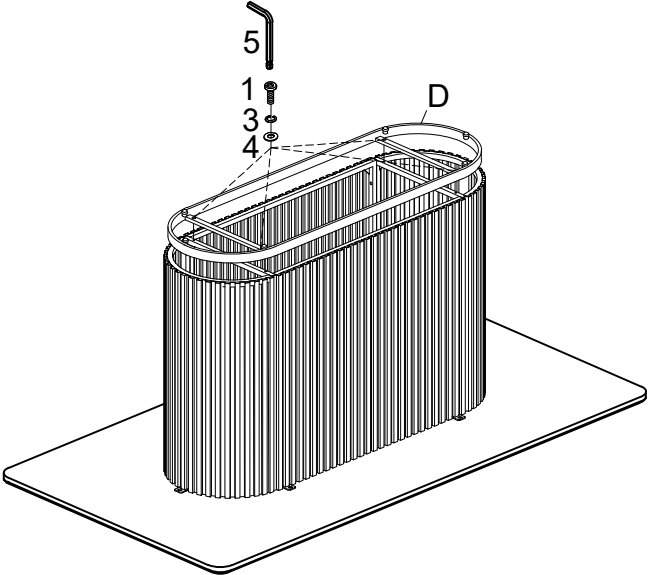

Step 6

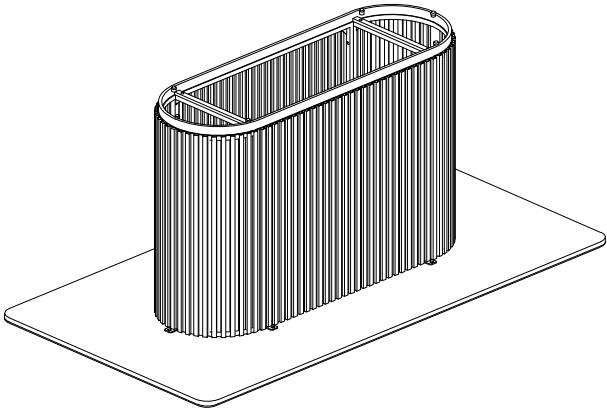

Note: Fully tighten all bolts at this step.

Step 7

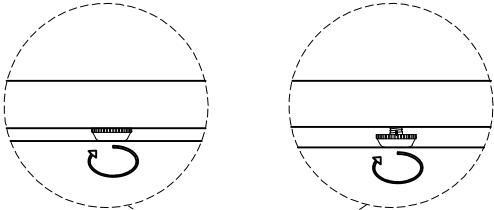
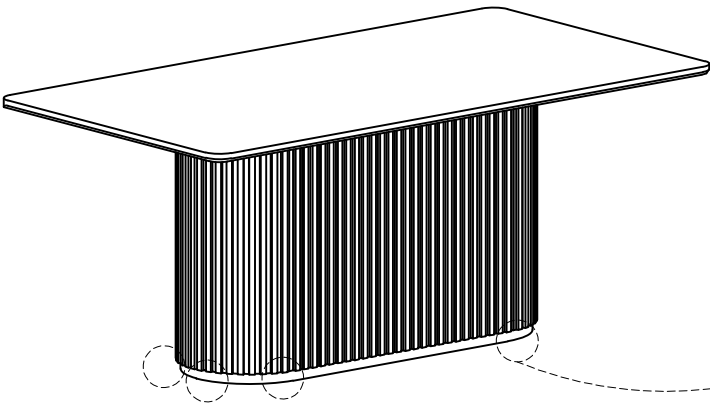

Adjust Pre-installed Levelers height to achieve balance