

# STEP 4

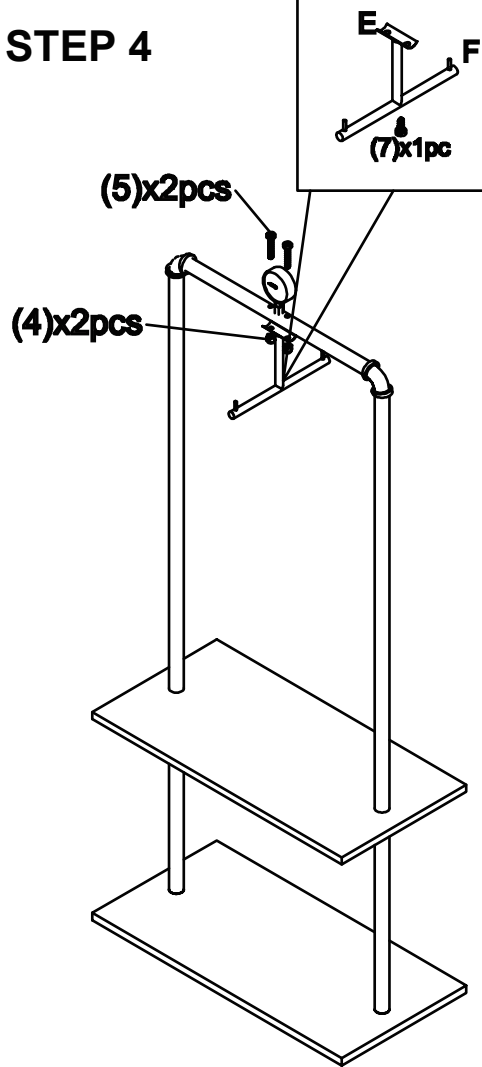

## Recommended Maximum Weight

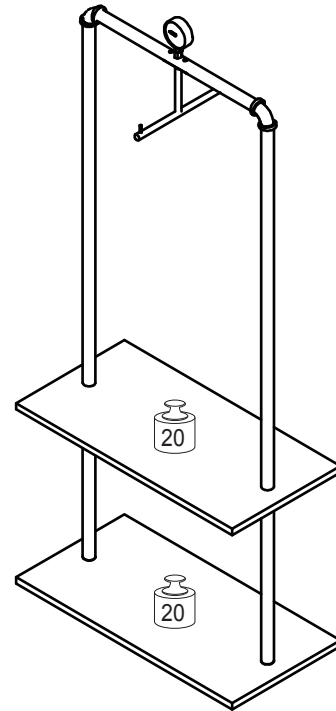

\*Unit in Pound(lbs)

### **WARNING:**

>This unit has been designed to support the maximum loads shown. Exceeding these load limits could cause sagging, instability, product collapse, and/or serious injury.

>DO NOT allow children to climb on unit.

>Put heavier items on lower shelves.

## Assembly Instruction

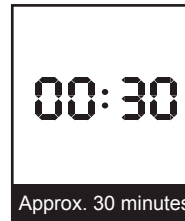

Approx. 30 minutes





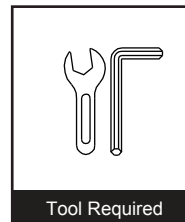



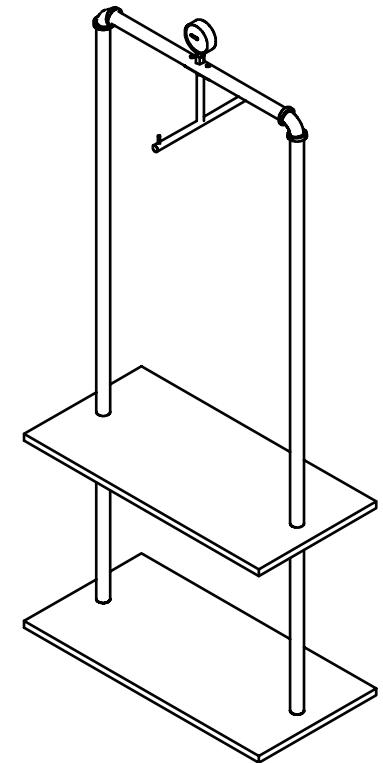







Recomm. 1 Person

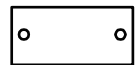
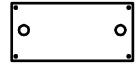

Tool Required

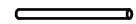

No	Hardware List	Qty
1		4pcs
2		6pcs
3		2pcs
4		2pcs
5		2pcs
6		2pcs
7		1pc
8		2pcs

No	Parts List	Qty
A		1pc
B		1pc
C		1pc
D		2pcs
E		1pc
F		1pc
G		1pc

### STEP 1

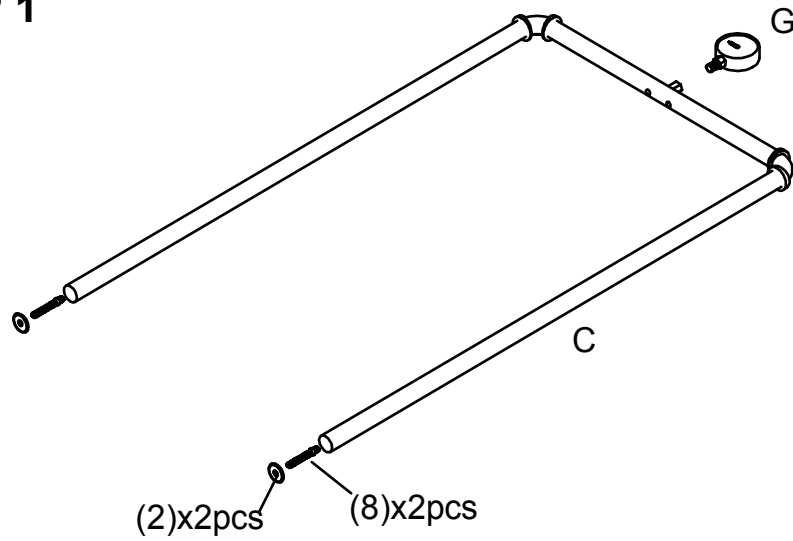

### STEP 2

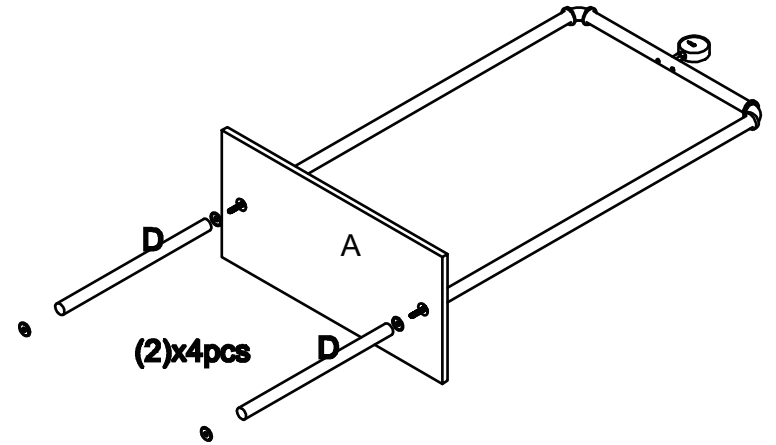

### STEP 3

