

Thank you for choosing . We stand behind our brand and the quality of the items we sell. Replacement parts or products can be requested within the 1-year warranty period. Proof of purchase must be provided. This includes the date of the purchase as well as photos of the product defect. Photos are used to determine the cause of the defect and to provide future quality control. The request will be reviewed, and replacement pieces will be sent at our discretion.

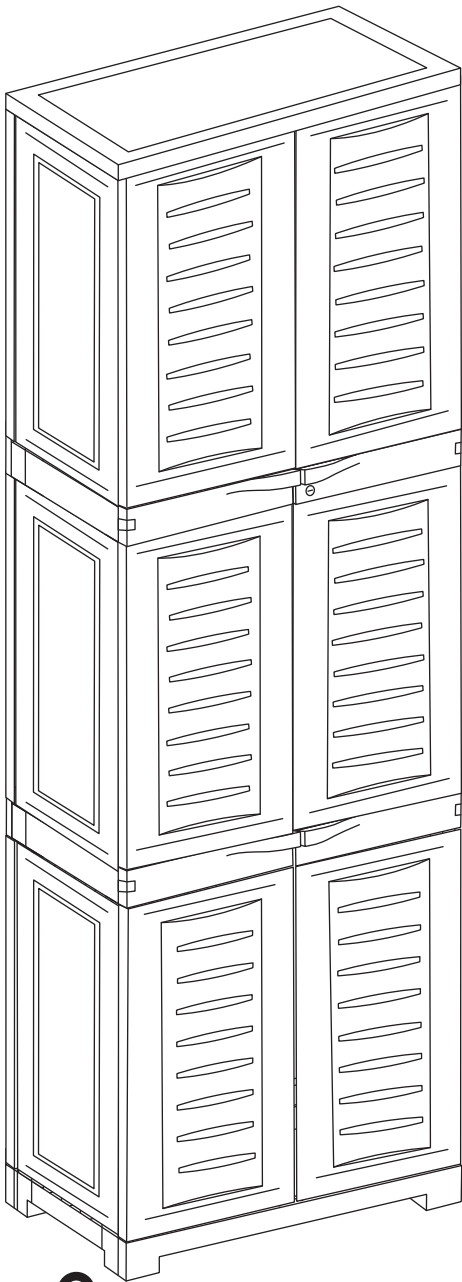





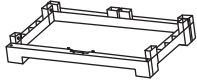

# LOCKABLE STORAGE CABINET WITH 4 ADJUSTABLE SHELVES

Review all assembly and care information before using this product. Save this manual for future reference.

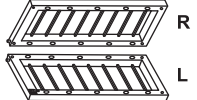
**Assemble components on a soft, clean surface to avoid damaging the finish.**

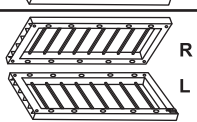

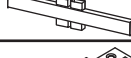
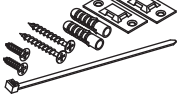

Inspect packaging to ensure all parts are accounted for before disposing of packing materials.  
Save the packing slip.

No.	CODE	PARTS		QTY.
1	TP		Top Panel	1
2	BT		Bottom Panel	1
3	SP		Side Panel	6
4	BP		Back Panel	6
5	TD		Top Door (L/R)	2
6	MD		Middle Door (L/R)	2
7	BD		Bottom Door (L/R)	2
8	SL		Shelf	4
9	DH		Door Handle (L/R)	4
10	SPL		Side Panel Link	4
11	BL		Back Panel Link	2
12			Anti-Tip Kit	1

**30 pounds**  
13.6 kg  
Weight Capacity per Shelf

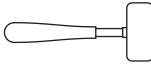
**CAUTION:**  
Distribute weight evenly throughout the unit to avoid tipping.

TOOLS REQUIRED (not included)	
	
Rubber Mallet	Power Drill with 5mm Bit

# ASSEMBLY

## STEP 1

### IMPORTANT:

Carefully follow all drawings to ensure components are installed facing the correct direction.

- BT: 1  
BP: 2

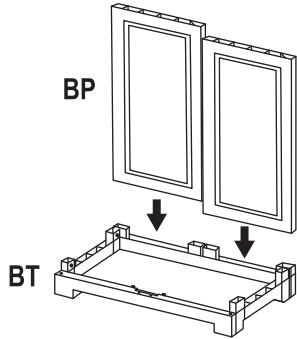

Affix two Back Panels (BP) to Bottom Panel (BT), as shown.

## STEP 2

- SP: 2

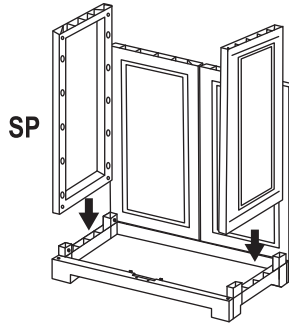

Affix two Side Panels (SP) to the bottom panel, as shown.

## STEP 3

- BL: 1  
SPL: 2

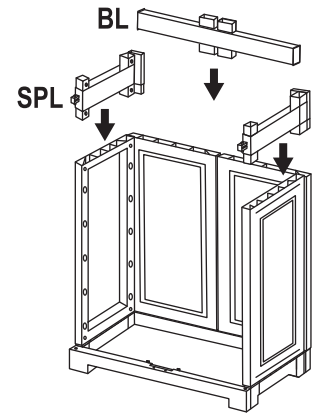

Affix one Back Link (BL) to the back panels.

Ensuring the door hinges are facing the front, affix two Side Links (SPL) to the side panels.

## STEP 4

- BP: 4  
SP: 4  
BL: 1  
SPL: 2

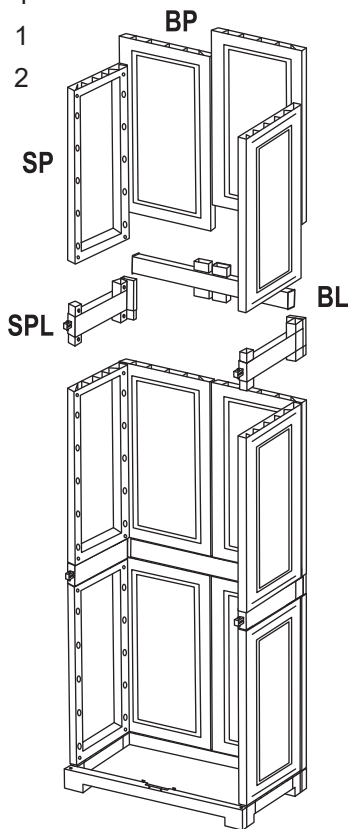

Repeat the previous steps to affix the remaining back panels, side panels, back link, and side links.

## STEP 5

### IMPORTANT:

Lay out all components to ensure they are assembled in the correct direction. Ensure door pivot pins are on the same side as the handle hinge.

- BD-L: 1  
BD-R: 1  
MD-L: 1  
MD-R: 1  
TD-L: 1  
TD-R: 1  
DH-L: 2  
DH-R: 2

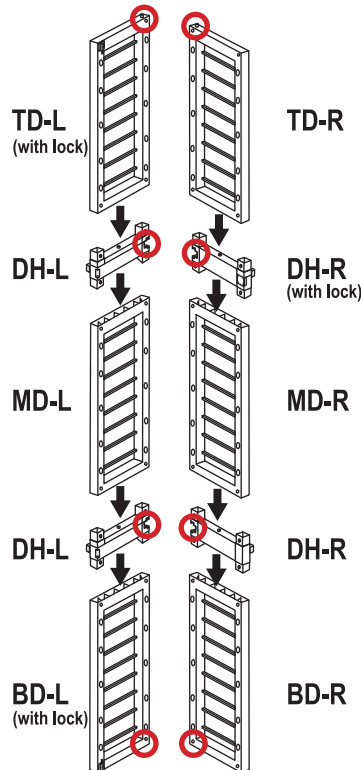

Assemble the doors as shown.

Top door, handle with lock, middle door, handle without lock, bottom door.

## STEP 6

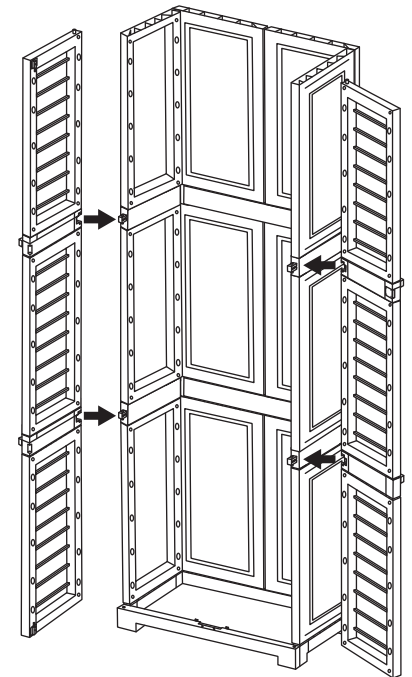
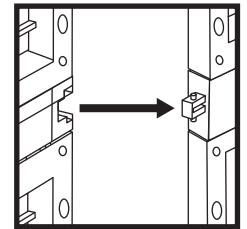

Align the pivot pin on the bottom bottom door with designated hole on the bottom panel of the cabinet. Then, firmly press the back of each door handle onto the cabinet hinges.

### STEP 7

TP: 1

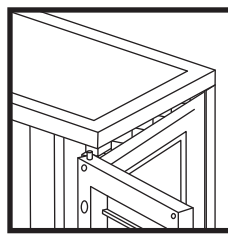
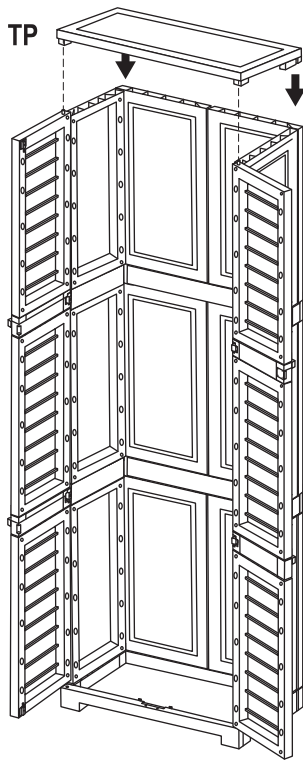

**IMPORTANT:**

The top is tight fitting. Working slowly and carefully, use a rubber mallet with light, even taps to assist in securing the top to the panels and doors.

Ensuring the pivot pins on the top doors align with the front of Top Panel (TP), firmly press the top to secure it to the unit.

### STEP 8

SL: 4

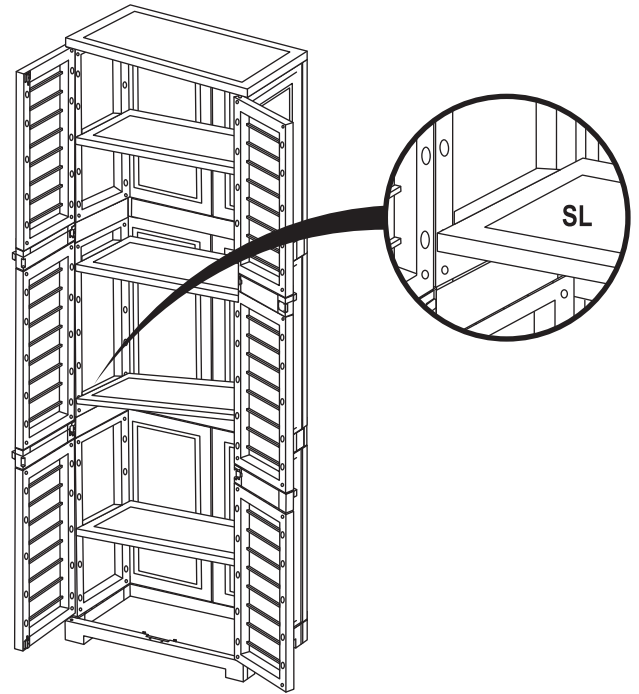

Install Shelves (SL) into the unit at a slight angle and align the shelf with one side of the unit. Then, gently press on the opposite side down until the shelf locks into place.

### STEP 9

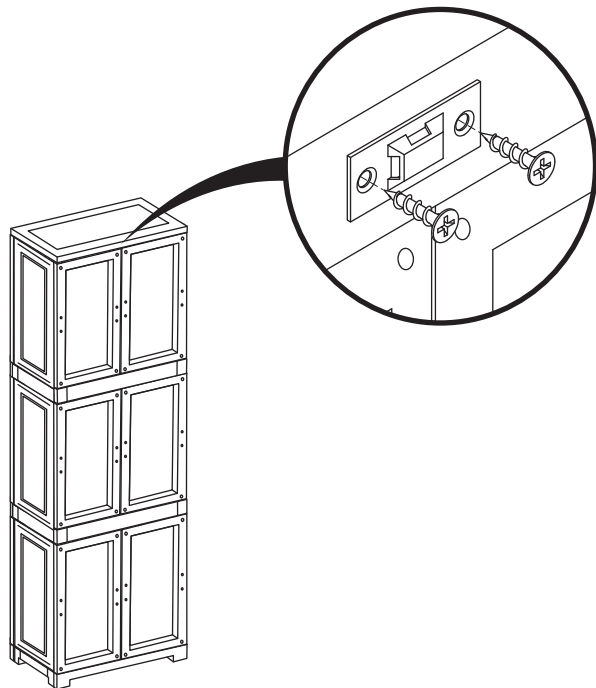

Secure one mounting tab to the back of the top panel using the short screws.

### STEP 10

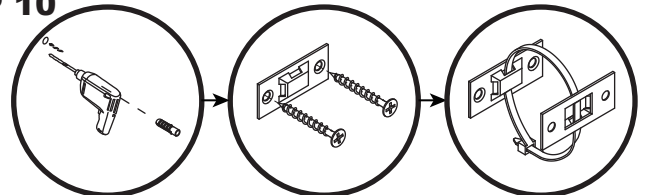

**WARNING:** Check for pipes and electrical wiring before drilling.

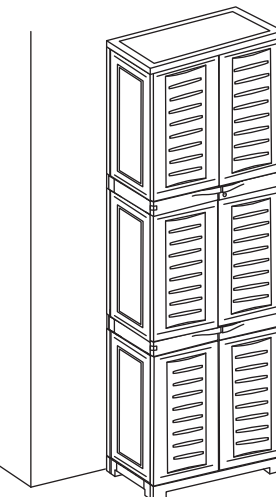

**IMPORTANT:** The anchors are designed for use with drywall only, other wall types will require special fittings (not included). When in doubt, consult a professional.

Carefully measure and mark the location of drywall anchor pilot hole before drilling and installing the unit.

Using a power drill with a 5mm bit, drill a hole to 30mm depth.

Insert the wall anchor into the hole until the opening is flush with the wall.

Secure the remaining mounting tab to the wall using the long screws.

Align the mounting tabs of the cabinet and wall, secure using the zip tie.

# Care & Maintenance

**SAFE USE:** Only use on a flat, level surface. Do not exceed the weight capacity of each shelf. To prevent sagging, ensure weight is evenly distributed. **DO NOT allow children or pets to play on OR inside the storage cabinet.** Keep doors closed and secured when not in use.

**CLEAN:** When necessary, hand wash the unit with a damp cloth. Do not use abrasive detergents, materials or cleaning tools.

To remove tough dirt and grime, mix mild detergent with warm water and use a soft cloth to gently scrub surfaces. Then, use a clean cloth and clean water to remove any residual detergent. If necessary, use a soft, lint-free cloth to dry the unit.

**INSPECT:** Occasionally check the unit to ensure all components are firmly secured and polypropylene is intact.

## SAFETY STATEMENTS & WARNINGS

- Keep this product on a flat, level surface.
- Do not stand or climb on any part of this unit.
- Do not exceed the weight capacity of the unit.
- Distribute weight evenly throughout the unit to avoid tipping.
- Do not allow children to use this product.
- Locking the unit when adults are not present is highly recommended.
- Do not use this item in the proximity of open flame or flammable/combustible chemicals.
- Keep furniture a safe distance from high-heat sources such as air vents, heaters, and grills.
- Do not place hot items on the unit.
- Do not use harsh chemicals or abrasive materials to clean this unit.
- This product is for residential use only; institutional or commercial use will void this warranty.

**Any modification to the product or failure to follow recommended care will void the product warranty.**

*If you experience issues with assembly or the product was damaged during transit, please contact our customer service team through one of the methods mentioned at the top of page 1.*

*Please have the item number and order information ready to expedite response time.*

## **WARNING!**

**Manufacturer and seller expressly disclaim any and all liability from personal injury, property damage or loss, whether direct or indirect, or incidental, resulting from the incorrect attachment, improper use, inadequate maintenance, or neglect of this product.**