

# Assembly Instructions

**Caution : You must read this before you proceed.**

## **CHAIR**

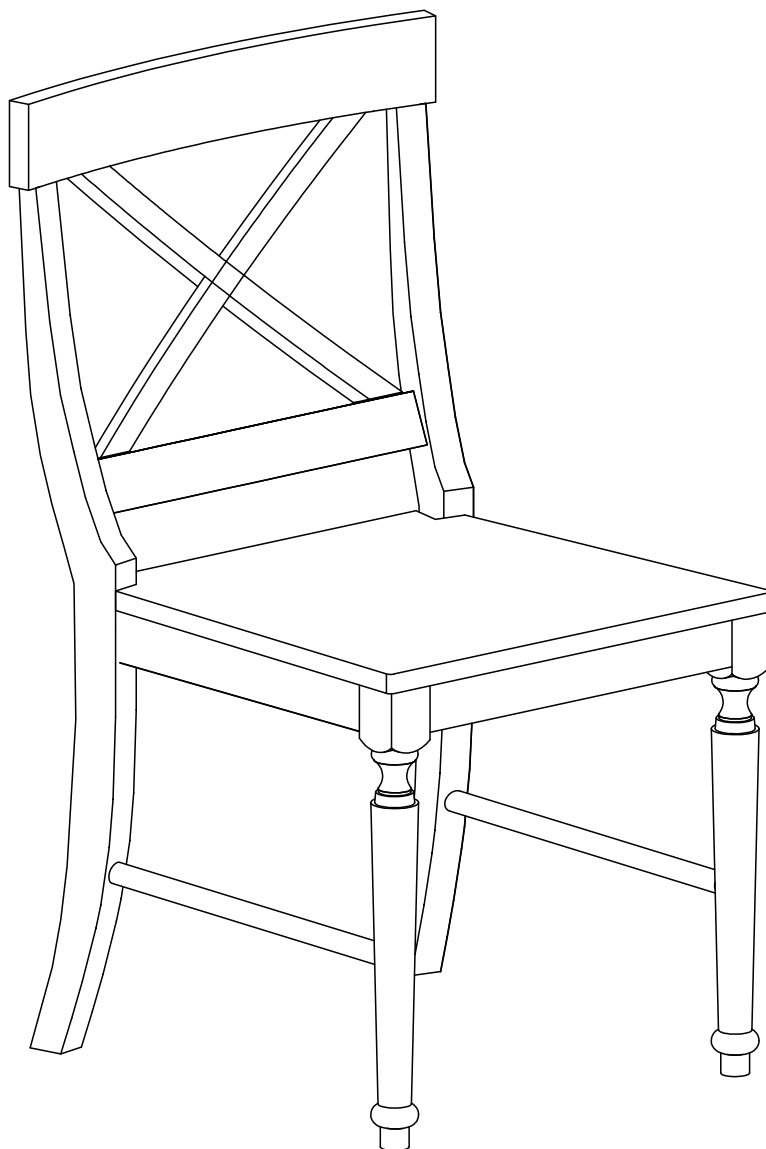



**CAUTION:** This Chair is NOT a TOY.

Keep your child / children at bay in the process of assembly.

For turning / flipping the Chair and to prevent damage to the Chair, 02 persons may be needed to execute this action.

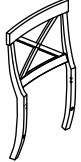
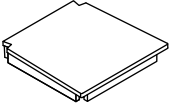
## Parts List

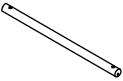
NO.	Picture	Description	QTY
A		Chair Back /Hind Legs	1
B		Chair Seat	1
C1		Left Front Legs (Labelled C1)	1
C2		Right Front Legs (Labelled C2)	1
D		Side Rails (the side with holes as bottom side to face the floor after assembled)	2

## Hardware

1		Bolts (M6x60mm)	9
2		Flat Washers	9
3		Screws (M4x40mm)	5
4		Spring Washers	9
5		Allen Key	1
6		Screwdriver	Not provided

## Assembly Preparation

Before Beginning Assembly:

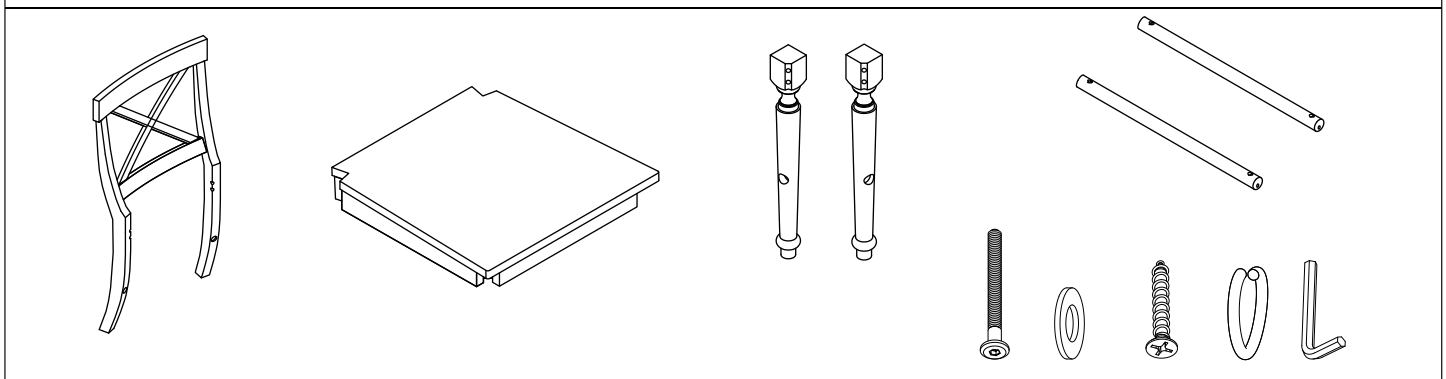

- Read instructions, cover to cover-



- Have 2 adults on hand for assembly-



- Do not assemble on flooring or carpet-



- Assemble on a clean non-marring surface (packing foam)-



- Save all packaging until finished-

## Assembly Steps

### OVERVIEW

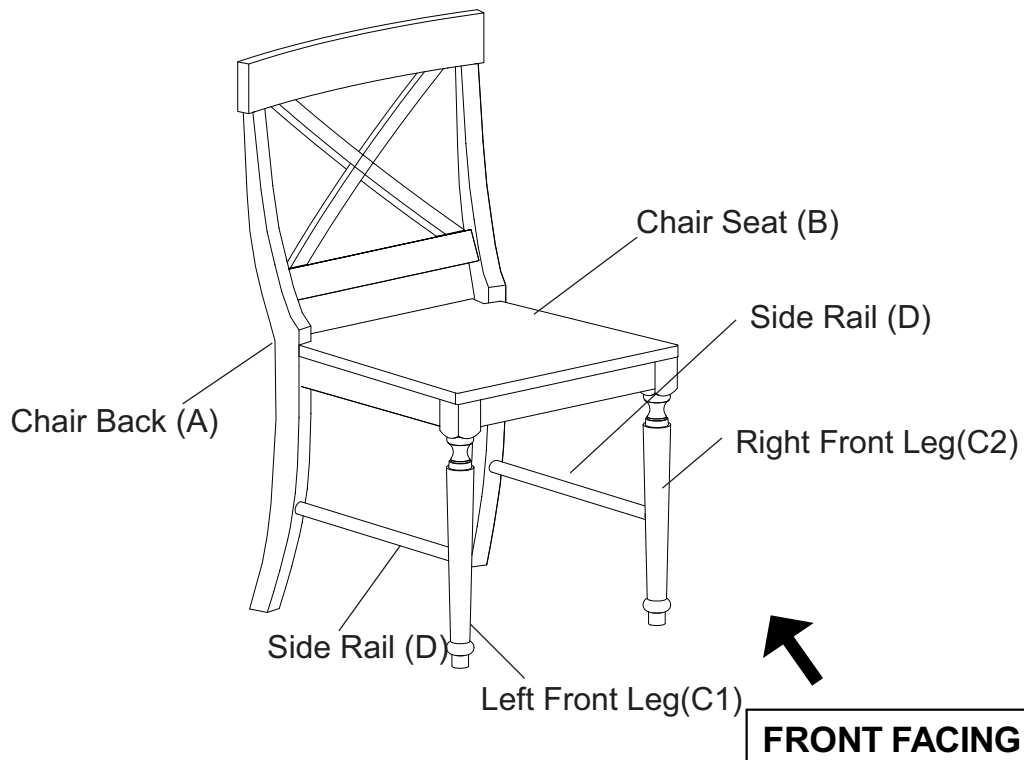

This Chair has multiple parts and may require up to some 30 minutes to assemble. To give you an overview of the Chair, the above picture is to help you put the various parts into perspective. Please read through the instruction below to familiarise yourself with the parts and steps before assembly.

### **Step 1**

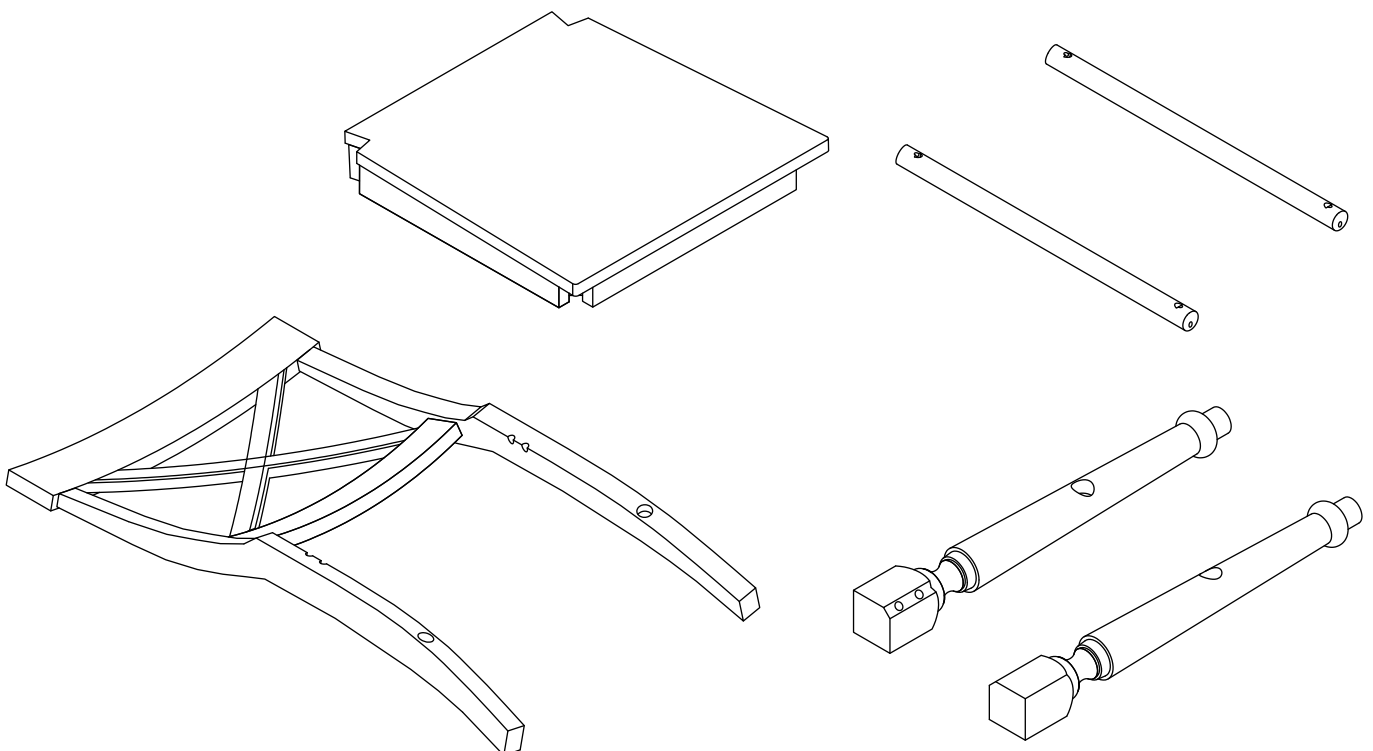

Unpack and place all parts on a clean soft surface.

## Step 2

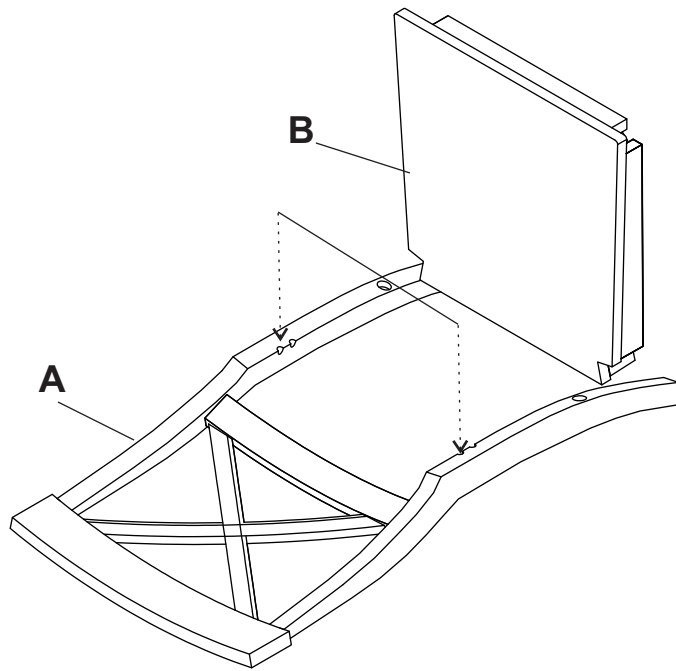

Place the Chair Back (A) onto a flat clean soft surface, as pictured above.  
Push the Chair Seat (B) in to the mounting position of the Chair Back (A)  
Use your left hand to push the seat frame floorwards.

This action helps to ensure the Chair Seat (B) is pressed towards to the Chair Back (A) with no gap between them.

## Step 3

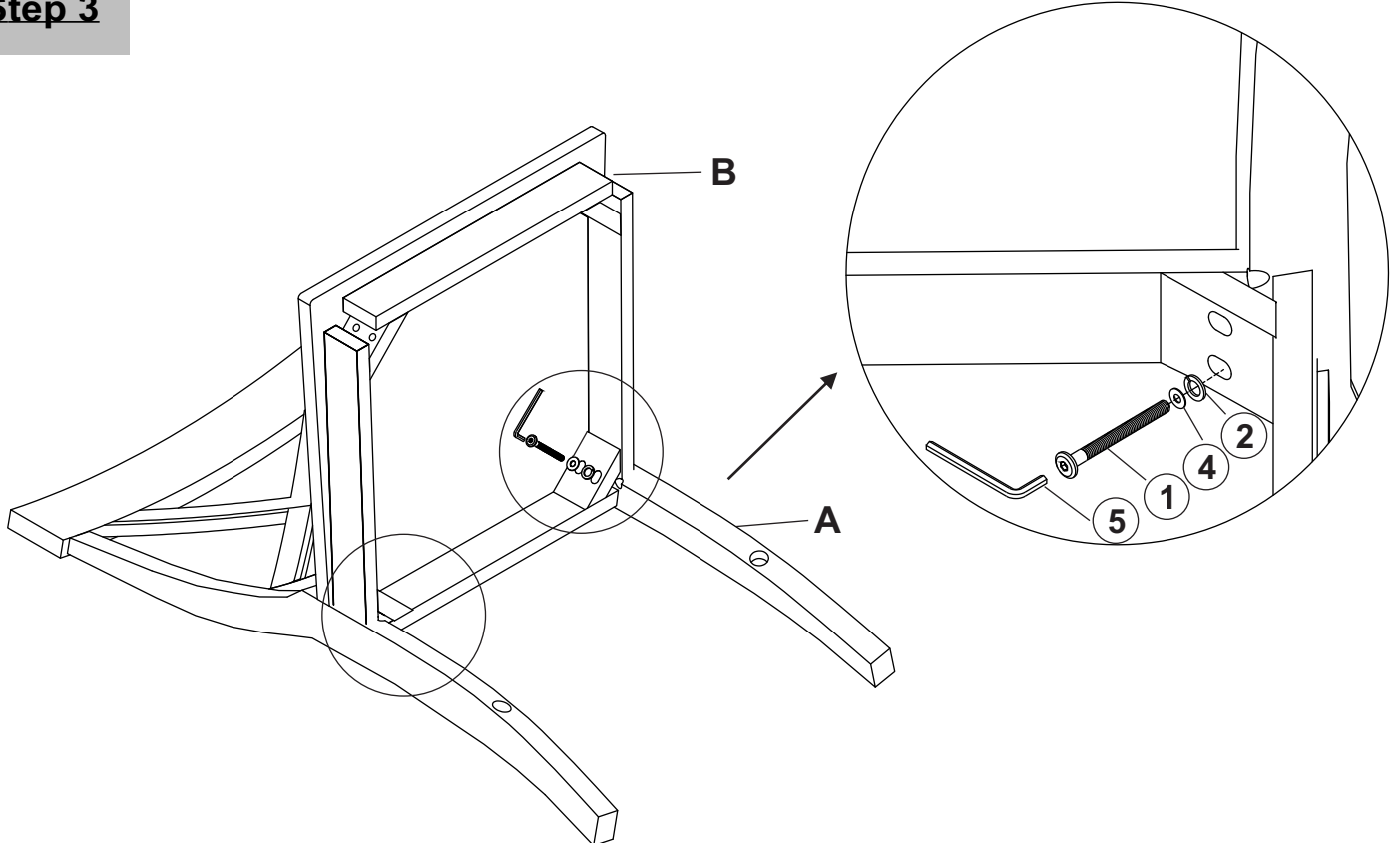

Secure the Chair Back (A) to the Chair Seat (B), using Bolt (1), Spring Washer (4) and Flat Washer (2) with AllenKey (5).

**Loosely tighten the Bolts up to 80%.**

#### Step 4

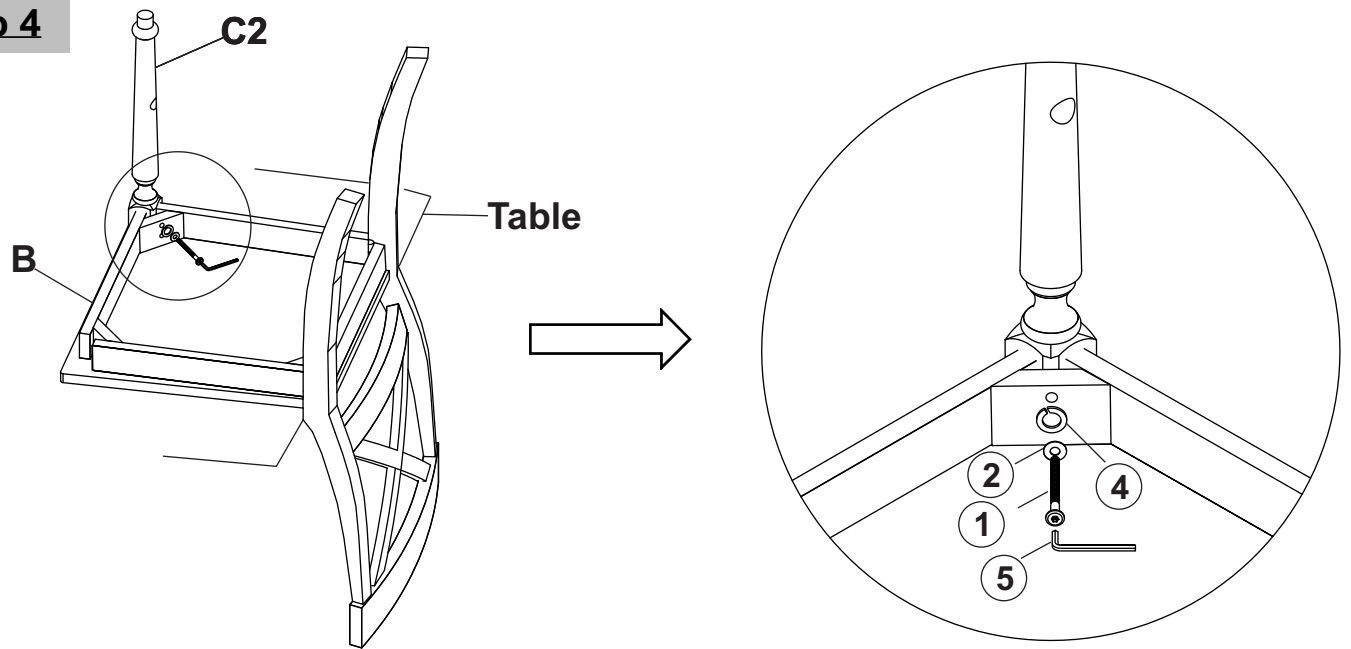

Next, place the Chair onto the side of a table as shown in picture.

You will have the chair bottom and legs facing skywards.

Place Right Front Leg (C2) into the Chair Seat (B)

Secure Right Front Leg (C2) to the Chair Seat (B) by using Bolt (1), Spring Washer (4) and Flat Washer (2) with Allen Key (5).

**Loosely tighten the Bolts up to 50%.**

Repeat the same process for the other Left Front Leg (C1)

#### Step 5

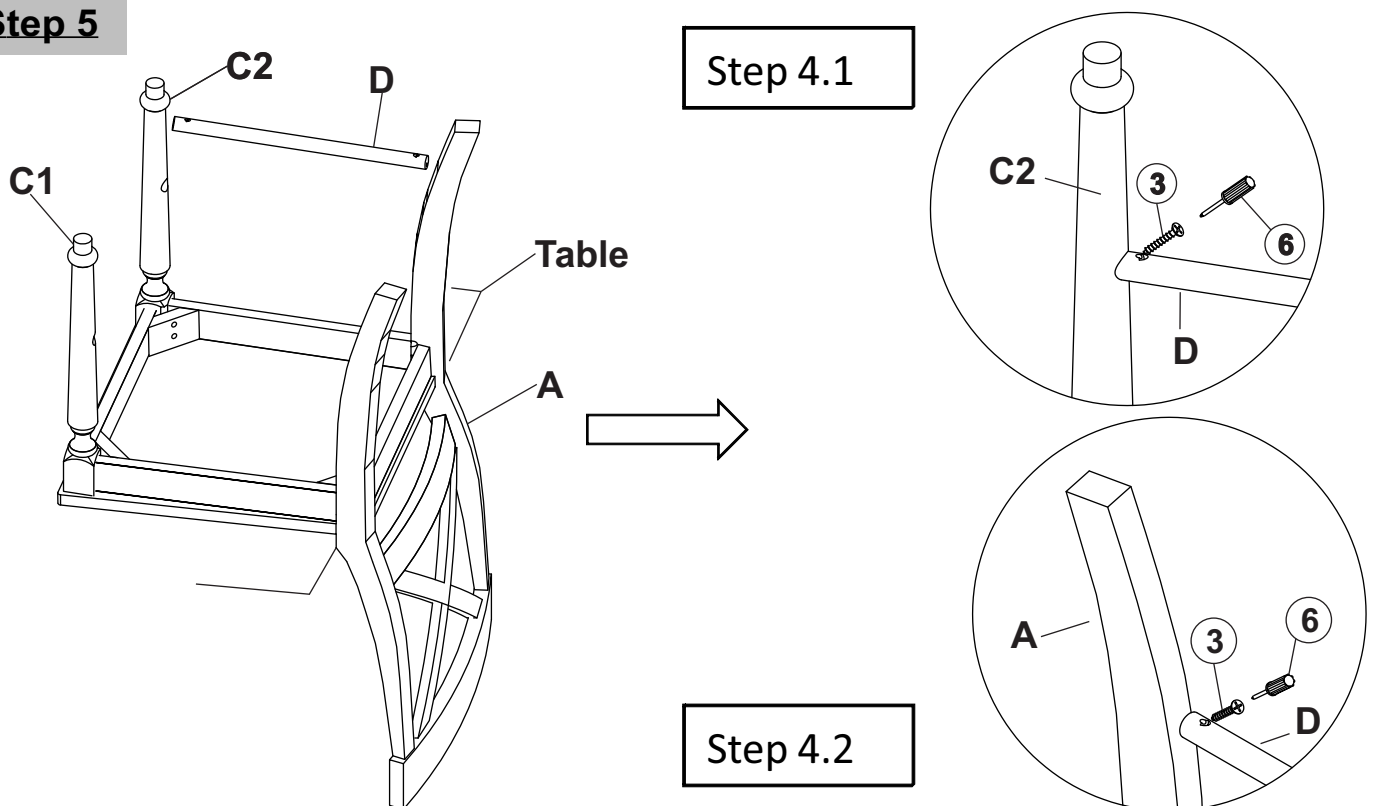

Then, place Side Rail (D) into the housing of the Hind Leg of the Chair Back (A) and Right Front Leg (C2). You may need to apply a little pressure to the Legs - pushing outwards, so as to enable the Side Rail (D) to slotted into position.

In step 4.1) Secure the Side Rail (D) to Right Front Leg (C2) by using Screw (3) and Screwdriver (6).

In step 4.2) Secure the Side Rail (D) to the Chair Back (A) by using Screw (3) and Screwdriver (6).

**Loosely tighten the Bolts up to 80%.**

Repeat the same process for the other Side Rail (D) to the Left Front Leg (C1)

## Step 6

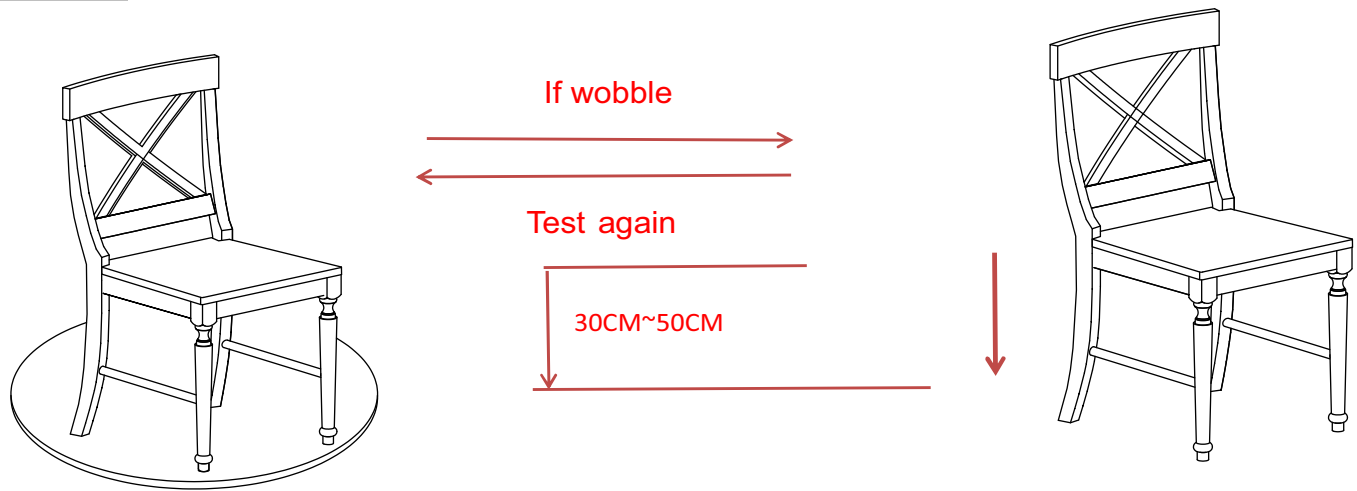

Place the Chair on a LEVEL SURFACE to see if it wobbles.

If it wobbles, lift the Chair to some 30cm to 50cm height from the ground.

Keep your feet and toes well away from the drop zone.

Drop the Chair freely and vertically with the four legs, hitting the ground, at the same time.

This Drop Test will help to ensure that all the screws and gaps to all reach full alignment status.

Test again for evenness on a LEVEL SURFACE.

If no wobbles found, proceed to tighten all the screws.

**CAUTION: When tightening these screws, tighten sequentially.**

**DO NOT tighten any screw fully and then towards the next one.**

**This would cause the frame to warp.**

**If there is still wobbles, loosen the screws and execute this same drop tests.**

**WARNING!! IF CHAIR IS NOT STABLE , IT COULD LEAD TO DAMAGING THE PRODUCT.**

## Step 7

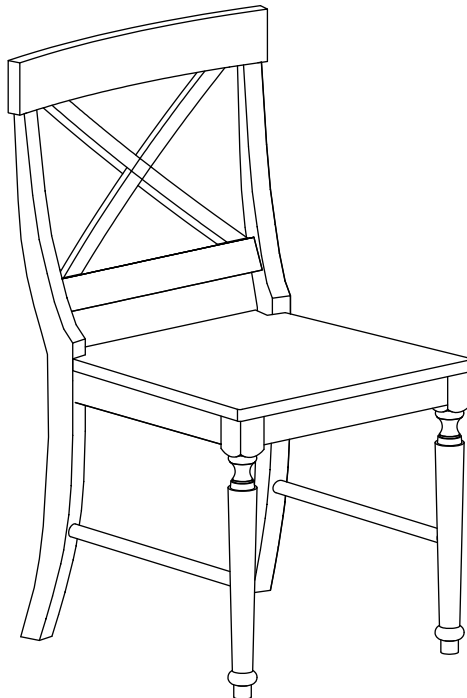



















Inspect the Chair and make sure all parts are connected.

Your Chair is ready for use

**Caution:** This Chair can only be used on a flat, level surface.

## Care & Maintenance

-   ● Do not put hot items directly on furniture surface
  -   ● Do not clean furniture with harsh cleansers or polish.
  -   ● Do not place furniture under direct sunlight.
  -   ● Do not place furniture near heating or cooling vents.
  -   ● Do not write on furniture without a padded barrier to protect the surface.
  -   ● Do not place furniture outside . For indoor use only .
  -   ● Not for commercial use. For residential use only .
  -  ● Stains may be removed with mild soap solution and damp cloth.
  -   ● Children should not climb or jump on the furniture.
- 
-   ● Dust and pick-up spills using a clean, noncolored, lint- cloth.

### Questions & Answers about Proposition 65

#### · What is Proposition 65?

Proposition 65 requires businesses to provide warnings to Californians about significant exposures to chemicals that cause cancer, birth defects or other reproductive harm. These chemicals can be in the products that Californians purchase, in their homes or workplaces, or that are released into the environment. By requiring that this information be provided, Proposition 65 enables Californians to make informed decisions about their exposures to these chemicals.

Proposition 65 also prohibits California businesses from knowingly discharging significant amounts of listed chemicals into sources of drinking water.

Proposition 65 requires California to publish a list of chemicals known to cause cancer, birth defects or other reproductive harm. This list, which must be updated at least once a year, has grown to include approximately 900 chemicals since it was first published in 1987.

#### · What types of chemicals are on the Proposition 65 list?

The list contains a wide range of naturally occurring and synthetic chemicals that include additives or ingredients in pesticides, common household products, food, drugs, dyes, or solvents. Listed chemicals may also be used in manufacturing and construction, or they may be byproducts of chemical processes, such as motor vehicle exhaust.

#### · What does a warning mean?

If a warning is placed on a product label or posted or distributed at a workplace, a business, or in rental housing, the business issuing the warning is aware or believes that it is exposing individuals to one or more listed chemicals.

By law, a warning must be given for listed chemicals unless the exposure is low enough to pose no significant risk of cancer or is significantly below levels observed to cause birth defects or other reproductive harm.

#### · Where can I get more information on Proposition 65?

If you have specific questions on the administration or implementation of Proposition 65, you can contact OEHHHA's Proposition 65 program at [P65.Questions@oehha.ca.gov](mailto:P65.Questions@oehha.ca.gov), or by phone at (916) 445-6900.