

We're here for you. Contact us at support.us@soforoom.com



X 2

Over The Toilet Storage Cabinet

Model: AP25-P1-US

NO:DET250808

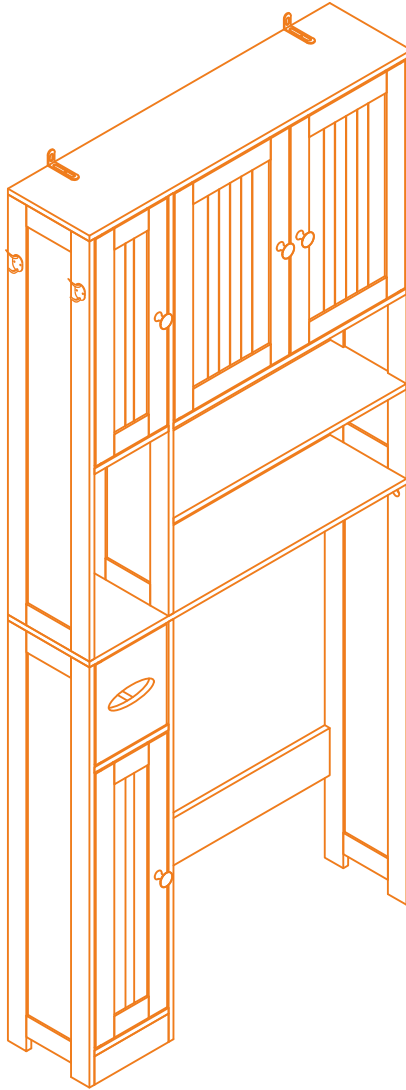

HELP CENTER

Have questions about this product? Contact us, and we'll assist you!

● Customer Support Email:

support.us@soforoom.com

* Upon receiving your email, we'll respond within **48** working hours.

CENTRO DE AYUDA

¿Tienes preguntas sobre tu producto? Ponte en contacto con nosotros y te ayudaremos.

● Correo electrónico de atención al cliente:

support.us@soforoom.com

*Al recibir tu correo electrónico, te responderemos en un plazo de **48** horas laborables.

FAQ

Q1: What should I do if the product I received is damaged or incorrect?

A1: If you've received a damaged, incorrect, or incomplete product, please reach out to our Customer Support Center at support.us@soforoom.com. Include your order number and photos

Q2: What should I do if I encounter problems during installation?

A2: If you encounter any installation issues, please email to support.us@soforoom.com, attach a detailed description of the problem, we will provide you with professional technical support.

Q3: How do I apply for a return?

A3: You can initiate a return within 30 days of purchase. Email us at support.us@soforoom.com with your order number and the reason for return. We'll guide you through the process.

Note:

- Please contact us before returning the product to avoid any complications.
- Ensure the product is returned in its original packaging with all accessories included.

PREGUNTAS FRECUENTES

P1: ¿Qué debo hacer si el producto que he recibido está dañado o es incorrecto?

R1: Si has recibido un producto dañado, incorrecto o incompleto, ponte en contacto con nuestro Centro de Atención al Cliente en support.us@soforoom.com. Incluye tu número de pedido y fotos que documenten el problema para que podamos ayudarte con la devolución o el cambio.

P2: ¿Qué debo hacer si encuentro problemas durante la instalación?

R2: Si tienes algún problema durante la instalación, por favor envía un correo electrónico a support.us@soforoom.com, adjuntando una descripción detallada del problema.

Te proporcionaremos soporte técnico profesional.

P3: ¿Cómo puedo solicitar una devolución?

R3: Puede iniciar una devolución en los 30 días siguientes a la compra. Envíenos un correo electrónico a support.us@soforoom.com con su número de pedido y el motivo de la devolución.

Te guiaremos a través del proceso.

Nota:

- Póngase en contacto con nosotros antes de devolver el producto para evitar complicaciones.
- Asegúrate de devolver el producto en su embalaje original y con todos los accesorios incluidos.

Product Guide and Care Instructions

EN

Thank you for purchasing our product! To ensure a smooth installation and a great user experience, please take a moment to read the following guidelines and instructions before you begin.

Assembly Instructions

- **Check Parts:** Before starting the installation, please inspect all parts and accessories for any damage or missing items. If you notice any issues, contact us immediately for assistance.
- **Safety First:** To avoid cuts from sharp panel edges during assembly, we recommend wearing gloves.
- **Work in a Spacious Area:** Assemble the product in a large, open space. Avoid stepping on the panels to prevent cracking or bending.
- **Refer to Diagrams:** We suggest using the provided diagrams during assembly to make the process easier. Start by aligning all screws with their corresponding pre-drilled holes, and once everything is in place, tighten each screw one by one.
- **Be Mindful of Torque:** When tightening screws, please be cautious with the amount of force you use. If you encounter any damaged parts, contact us right away.

Safety Warnings

- **Child Safety:**
This product is not suitable for children under 3 years old. During assembly, keep small parts out of reach of children. Adult supervision is required when children are using this product.

Usage Limitations

- **Stable Surface:**
Ensure the product is placed on a flat surface. Do not sit or stand on it, and children should not climb or play on it—doing so may result in serious injury if the product tips over.

Product Use

- **Final Checks:**
After assembly, please double-check that all screws are tightened and the product is stable before use.
- **Indoor Use Only:**
This product is designed for indoor use only. We are not responsible for any damage caused by improper use or modifications.

Product Care

- **Environmental Conditions:**
Keep the product away from direct sunlight, rain, and damp conditions to prevent warping, fading, or cracking. Additionally, keep it away from sharp objects and corrosive materials to protect the surface.
- **Cleaning:**
For regular maintenance, wipe the surface with a damp cloth and dry it immediately. Avoid using abrasive cleaners that may scratch the surface.

By following these guidelines, you can enjoy a safe and pleasant experience with our product. Thank you for choosing us!

Guía del Producto e Instrucciones de Cuidado

ES

¡Gracias por adquirir nuestro producto! Para garantizar una instalación sencilla y una excelente experiencia de uso, le recomendamos leer atentamente las siguientes instrucciones antes de comenzar.

Instrucciones de Montaje

- **Verificar las Piezas:** Antes de iniciar la instalación, revise todas las piezas y accesorios para asegurarse de que no haya daños ni faltantes. Si detecta algún problema, contáctenos de inmediato para recibir asistencia.
- **Seguridad Primero:** Para evitar cortes con los bordes afilados de los paneles durante el ensamblaje, recomendamos usar guantes.
- **Espacio de Trabajo Adecuado:** Ensamble el producto en un área amplia y despejada. Evite pisar los paneles para prevenir grietas o deformaciones.
- **Uso de los Diagramas:** Le sugerimos seguir los diagramas proporcionados para facilitar el proceso de montaje. Alinee todos los tornillos con los orificios pre-perforados correspondientes y, una vez que todo esté en su lugar, apriete cada tornillo uno por uno.
- **Cuidado con la Fuerza Aplicada:** Al apretar los tornillos, tenga cuidado con la cantidad de fuerza utilizada. Si encuentra alguna pieza dañada, contáctenos de inmediato.

Advertencias de Seguridad

- **Seguridad Infantil:**
Este producto no es apto para niños menores de 3 años. Durante el montaje, mantenga las piezas pequeñas fuera del alcance de los niños. Se recomienda la supervisión de un adulto cuando los niños utilicen el producto.

Limitaciones de Uso

- **Superficie Estable:**
Asegúrese de colocar el producto sobre una superficie plana. No se sienta ni se pare sobre él. Los niños no deben trepar ni jugar en el producto, ya que esto podría provocar accidentes graves si se vuelca.

Uso del Producto

- **Verificación Final:**
Después del montaje, asegúrese de que todos los tornillos estén bien apretados y que el producto sea estable antes de usarlo.
- **Solo para Uso en Interiores:**
Este producto está diseñado exclusivamente para uso en interiores. No nos hacemos responsables de los daños causados por un uso inadecuado o modificaciones del producto.

Cuidado del Producto

- **Condiciones Ambientales:**
Mantenga el producto alejado de la luz solar directa, la lluvia y la humedad para evitar deformaciones, decoloración o grietas. Además, protéjalo de objetos afilados y materiales corrosivos para conservar su superficie en buen estado.
- **Limpieza:**
Para su mantenimiento, limpie la superficie con un paño húmedo y séquela inmediatamente. Evite el uso de productos abrasivos que puedan rayar la superficie.

Siguiendo estas recomendaciones, podrá disfrutar de una experiencia segura y satisfactoria con nuestro producto. ¡Gracias por elegirnos!

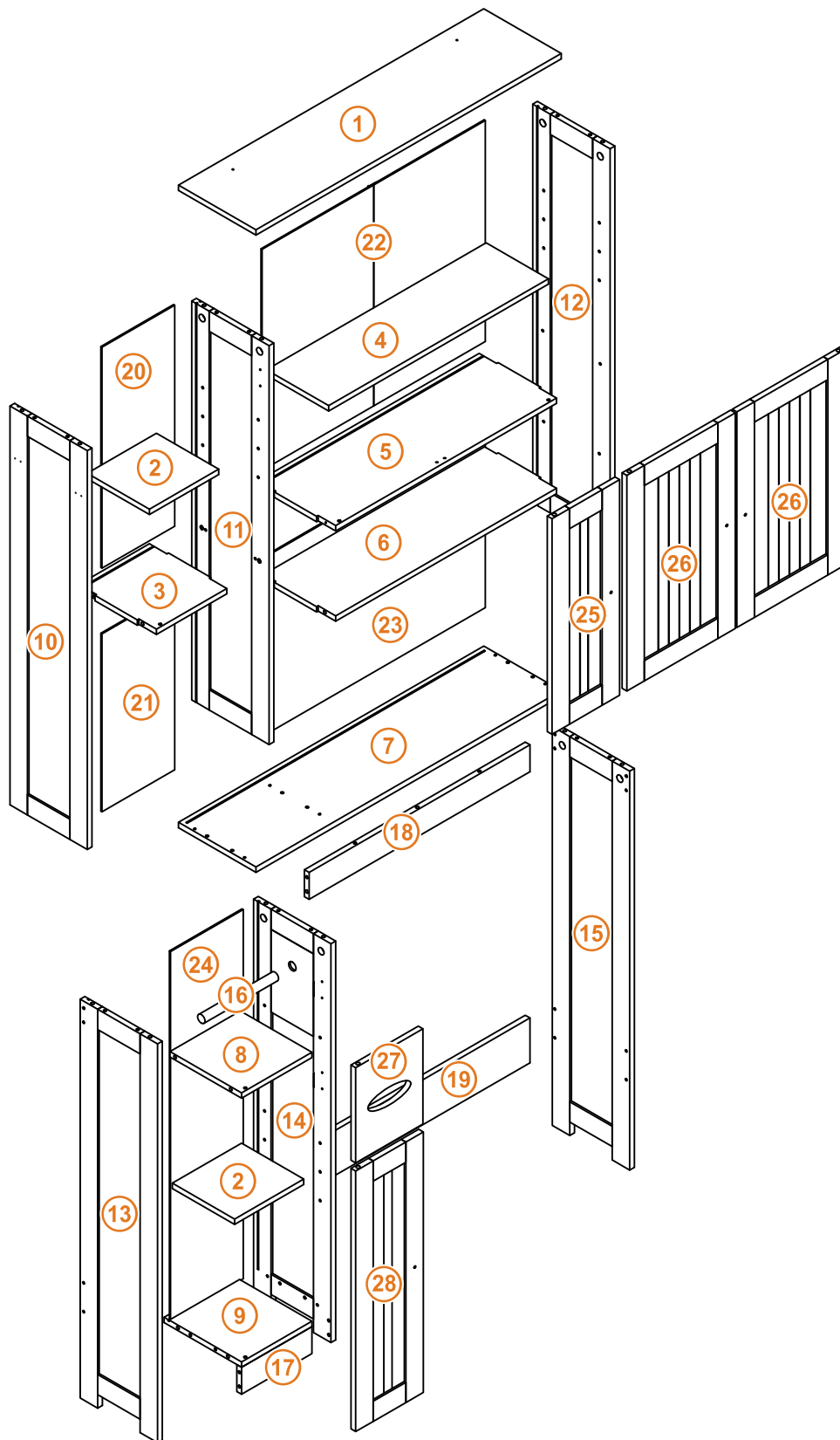

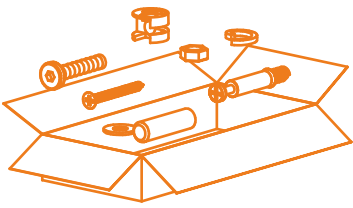

A x37+3

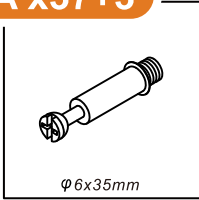

B x37+3

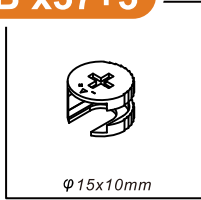

C x30+3

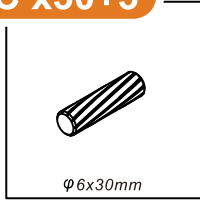

D x10+1



E x26+2



F x16+1

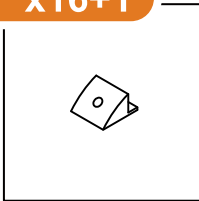

G x4



H x4



I x2

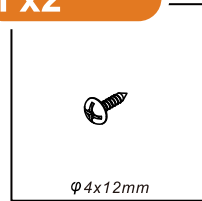

J x2

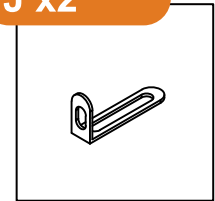

K x2

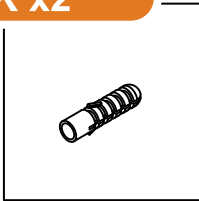

L x7

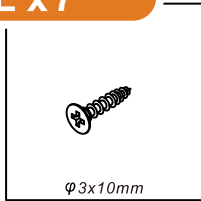

M x7

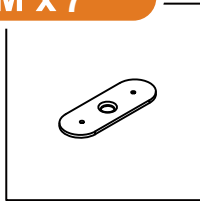

N x5

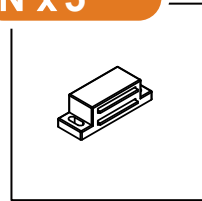

O x10

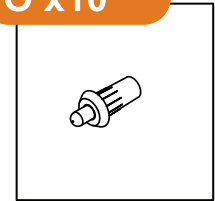

P x12

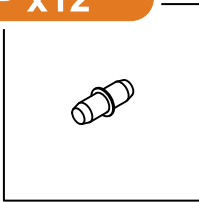

Q x1

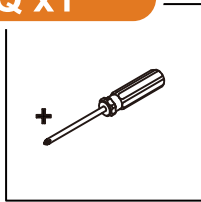

R x4

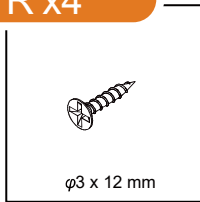

S x2

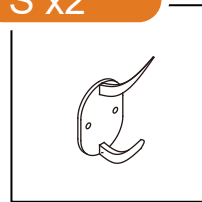

T x14

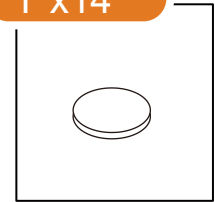

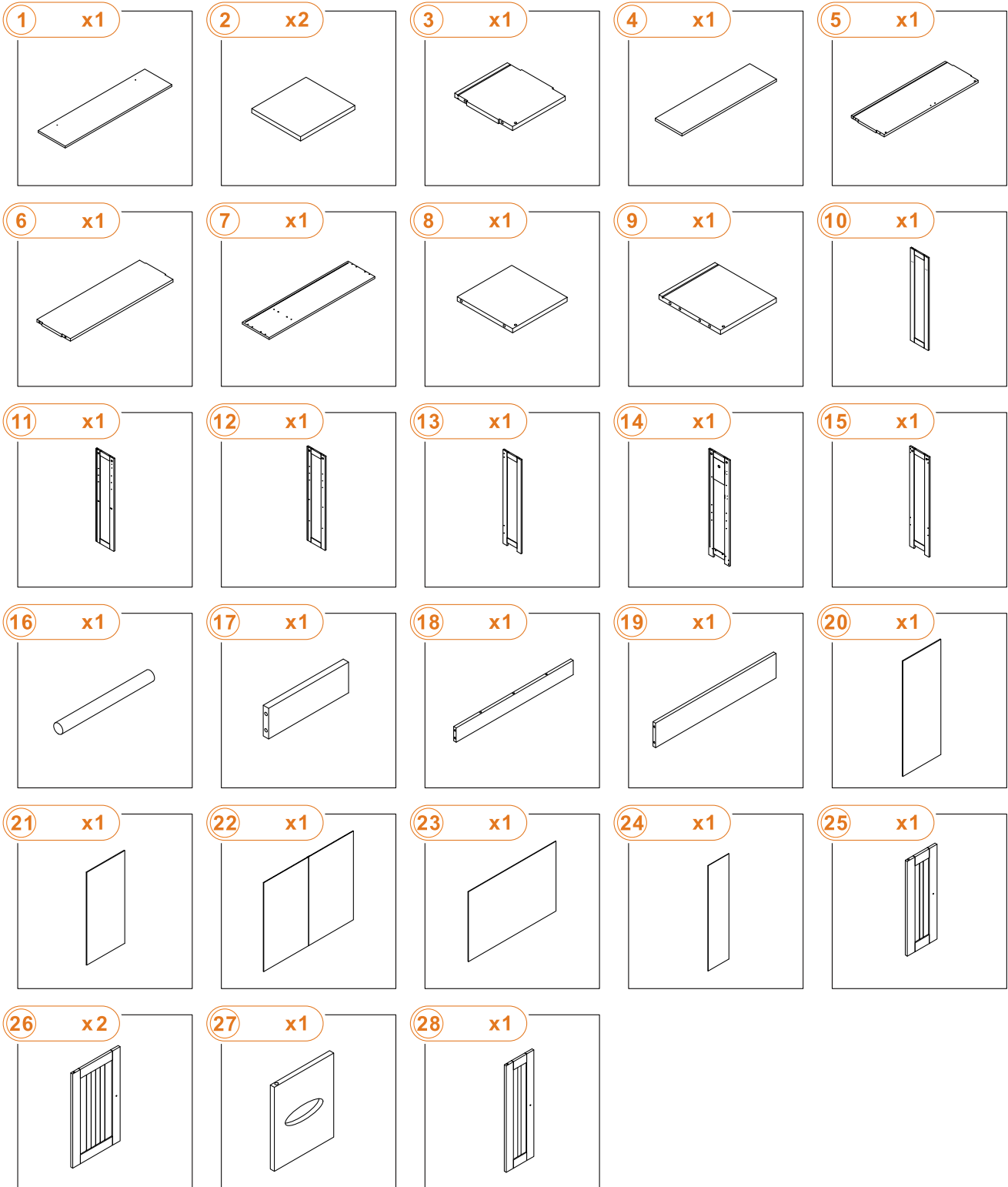
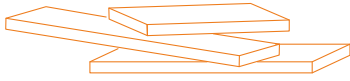

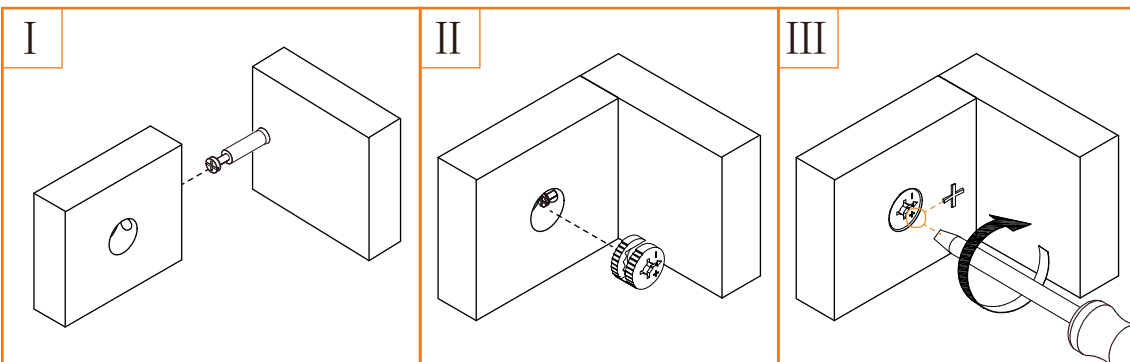
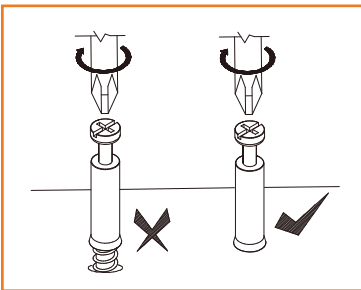
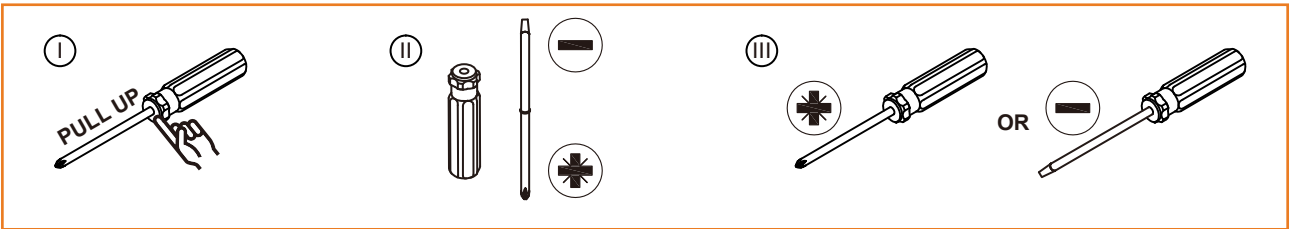
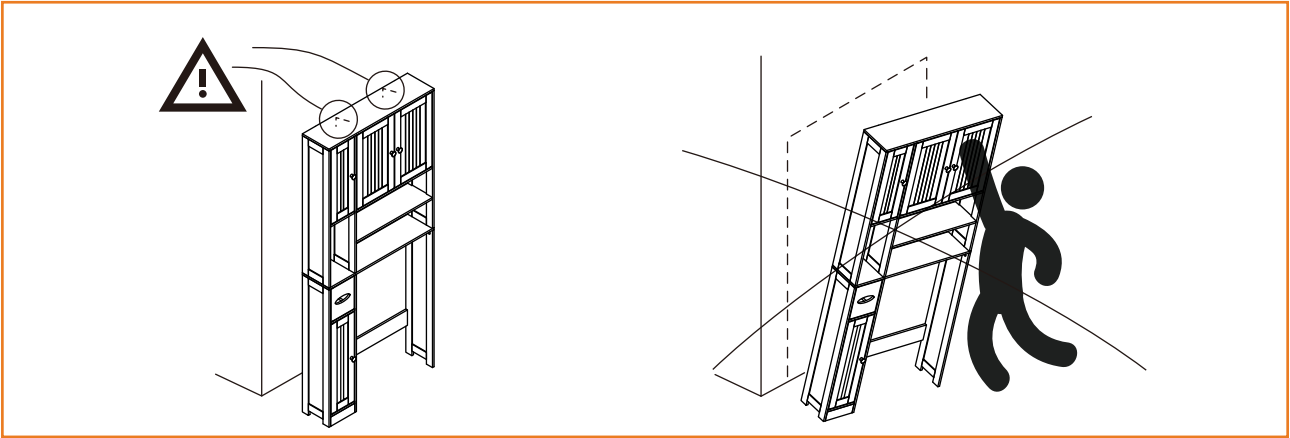

1

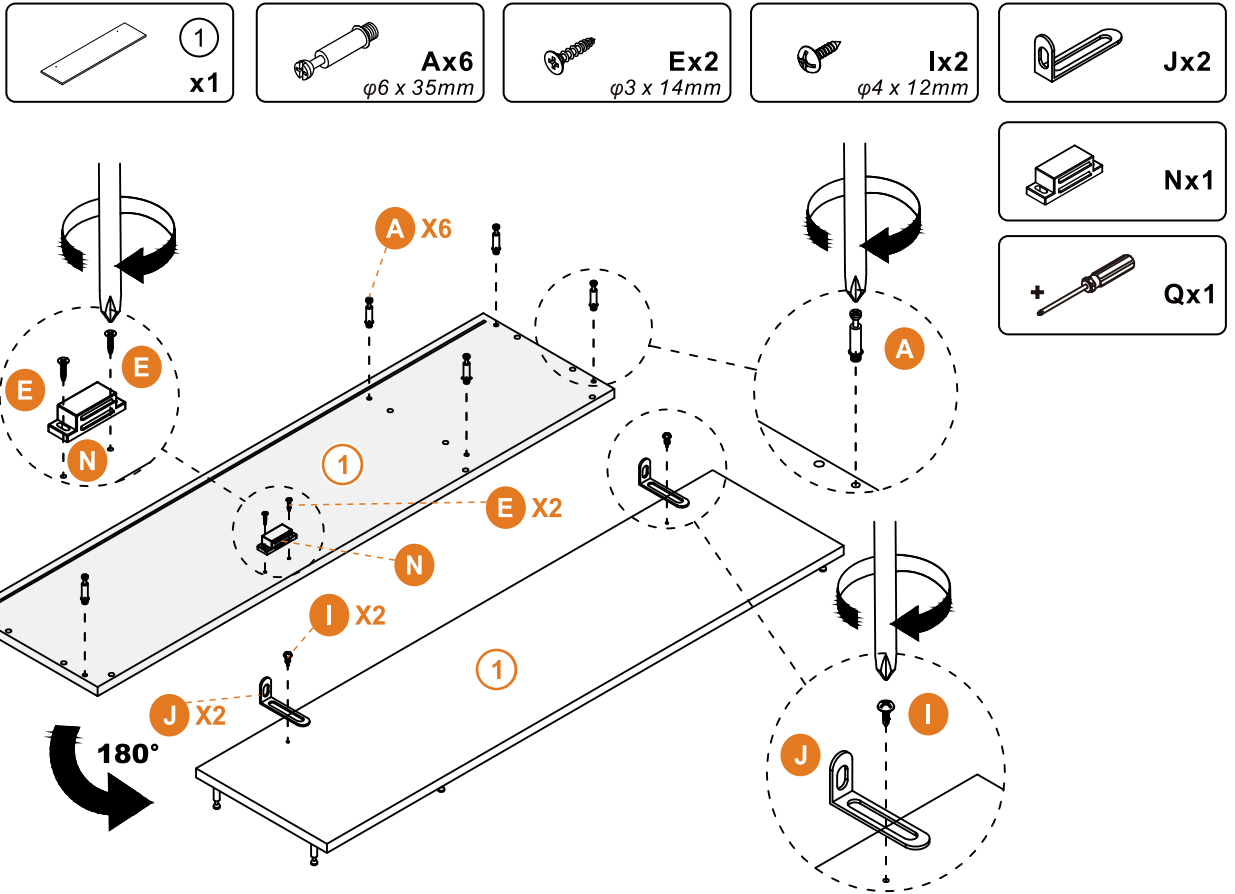

2

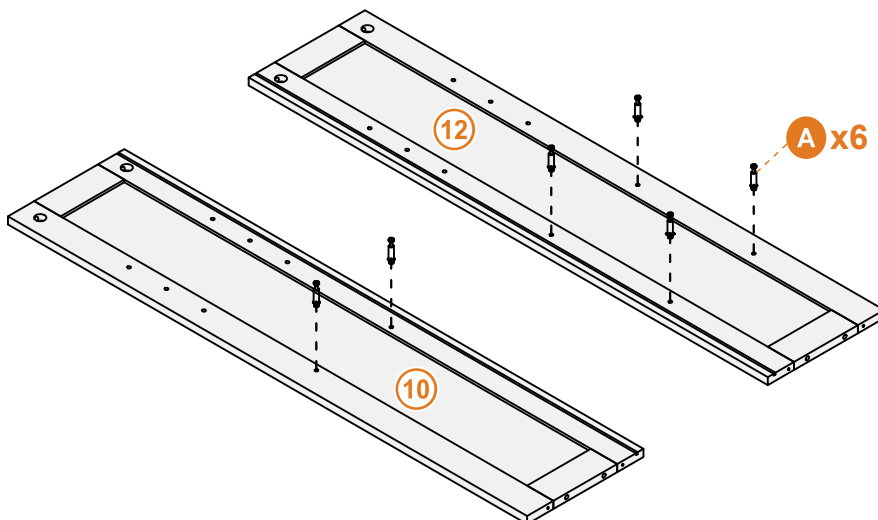
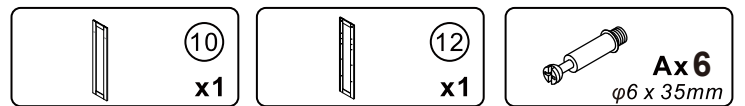

3

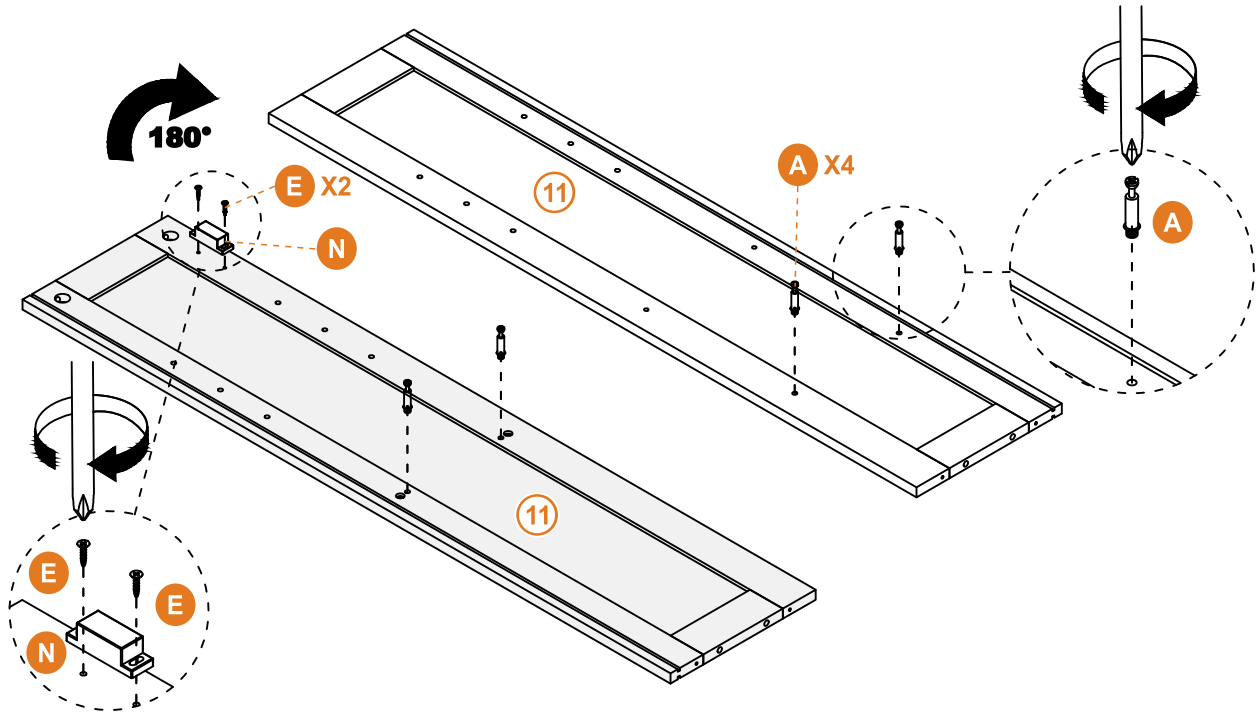
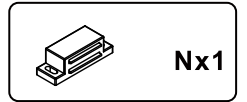
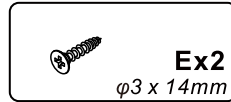
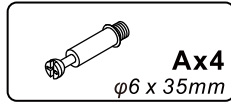
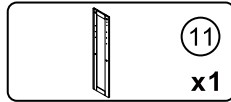

4

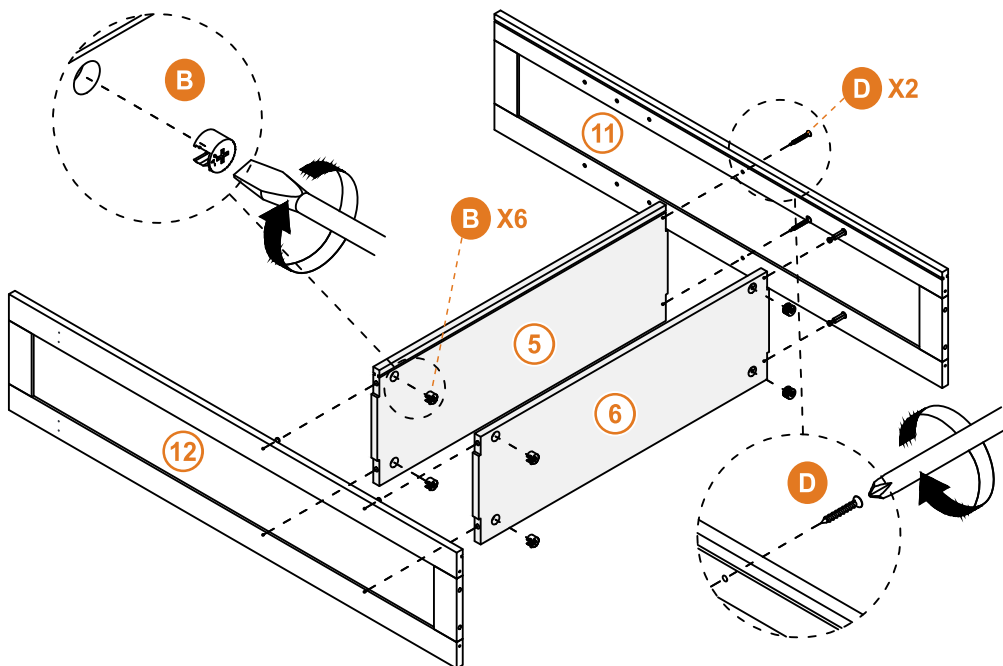
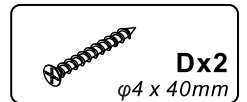
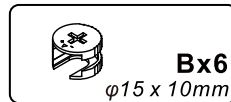
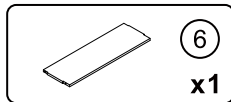
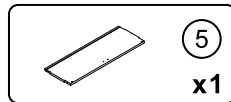

5

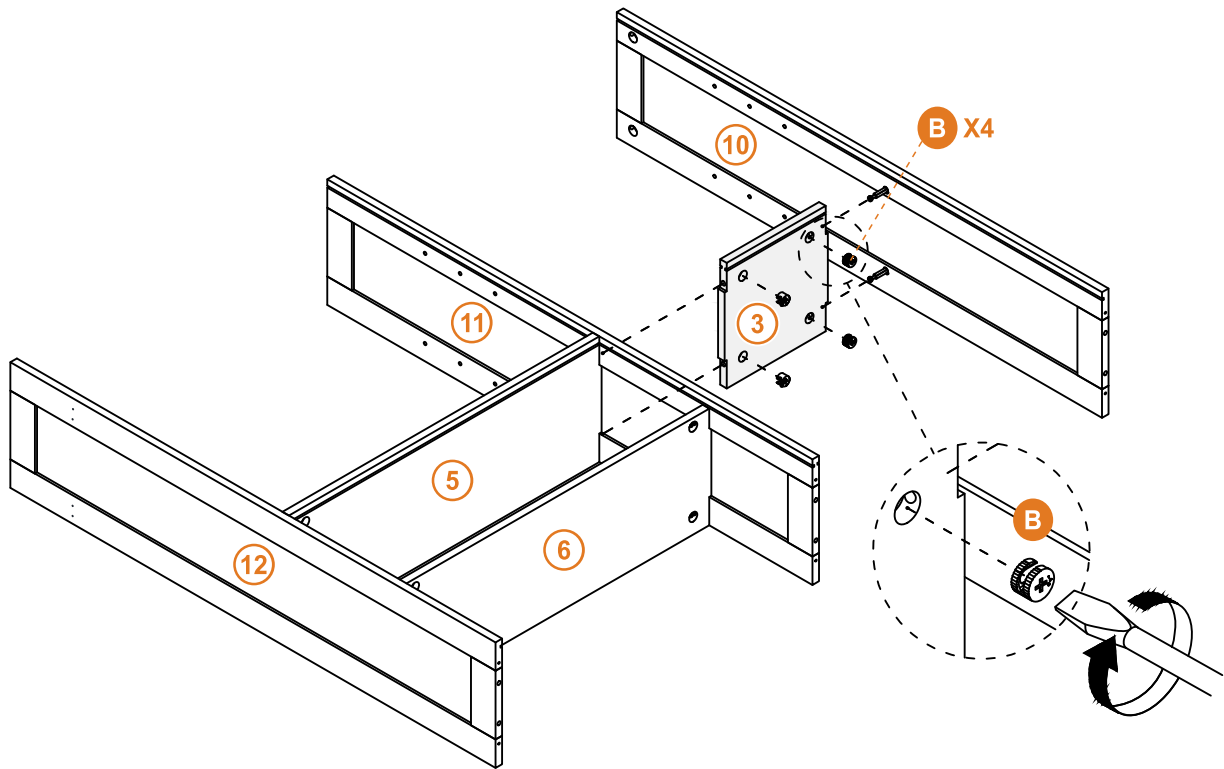
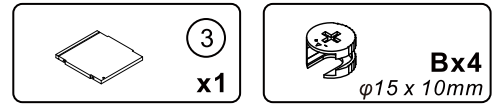

6

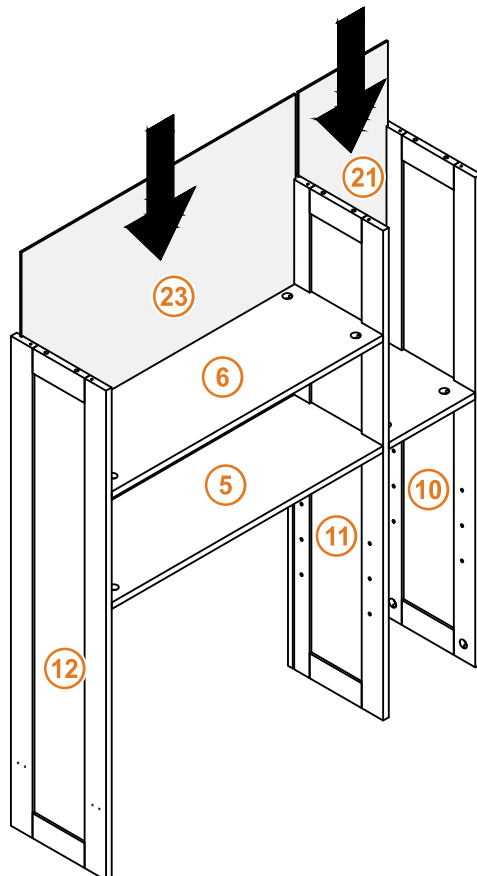
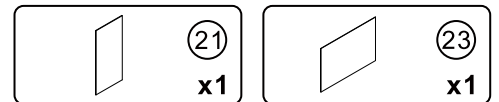

7

Version 1: Step 8-25

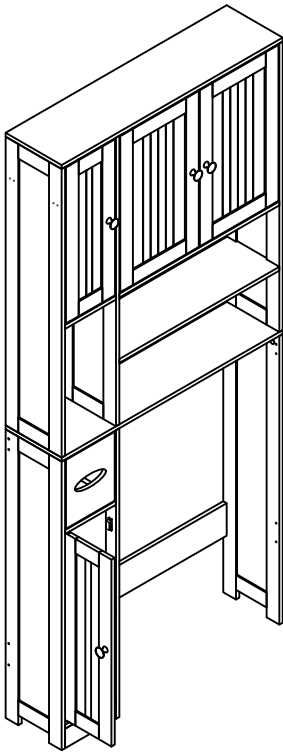

Version 2: Step 26-42

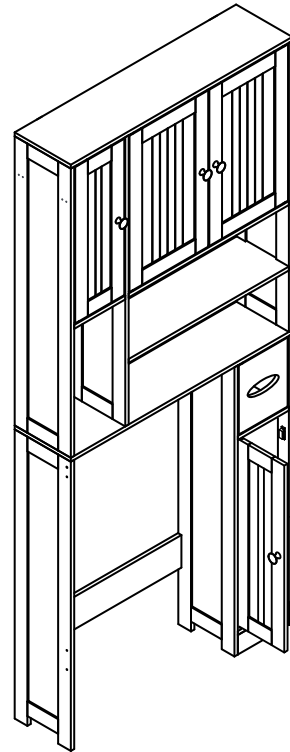

8

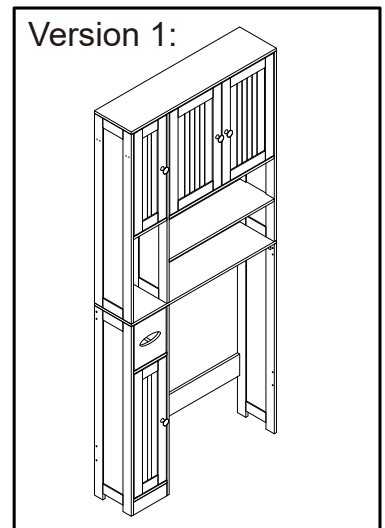
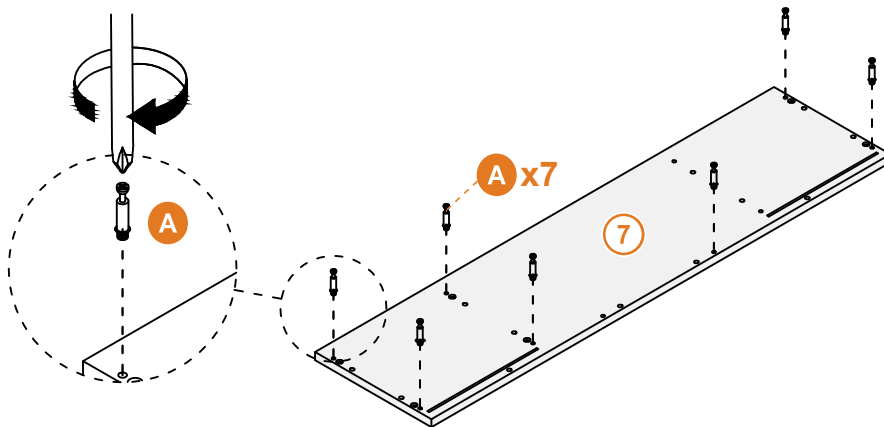
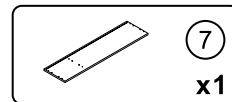

9

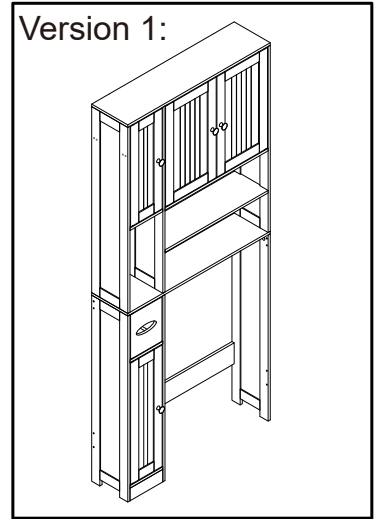
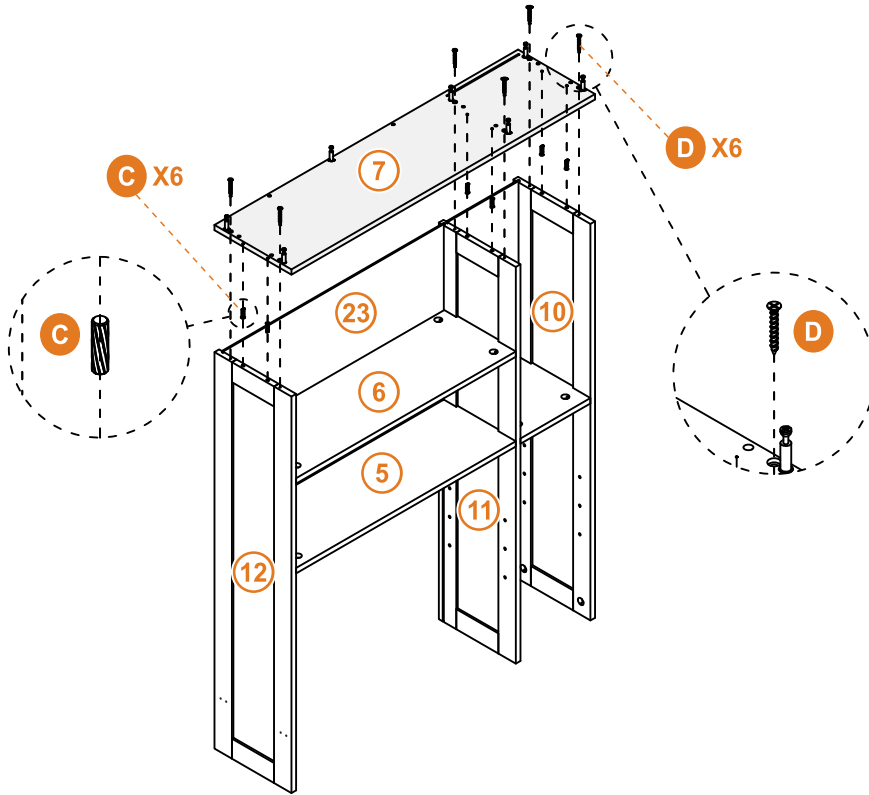
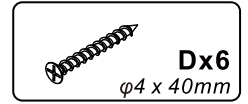
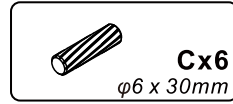

10

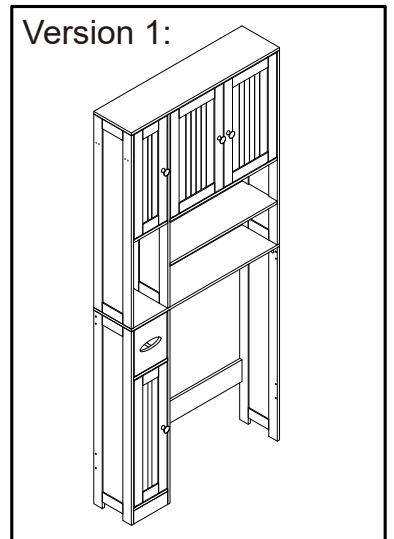
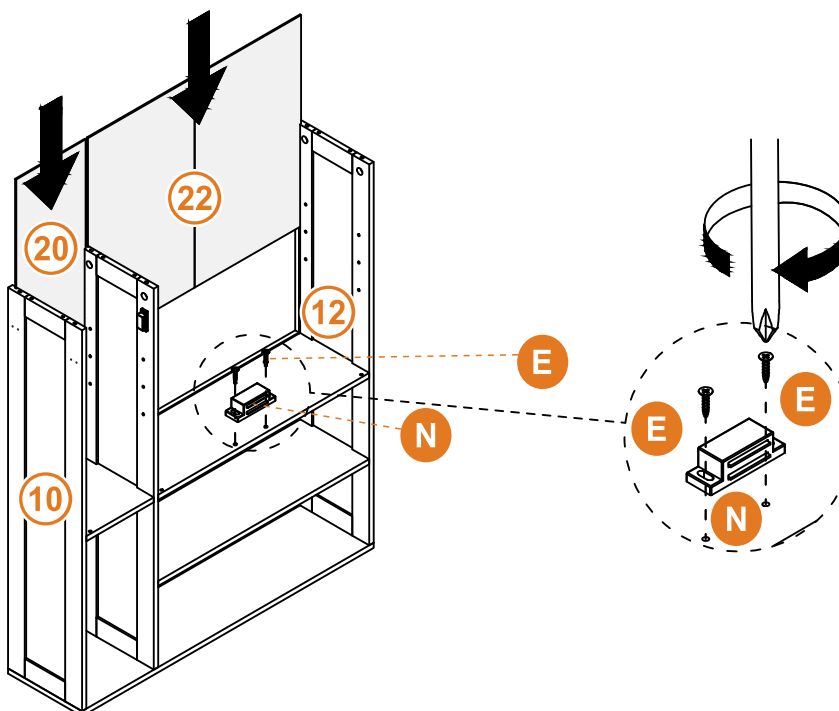
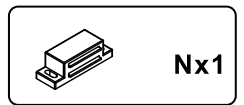
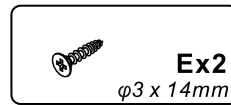
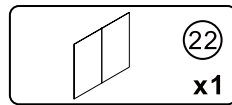
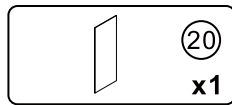

11

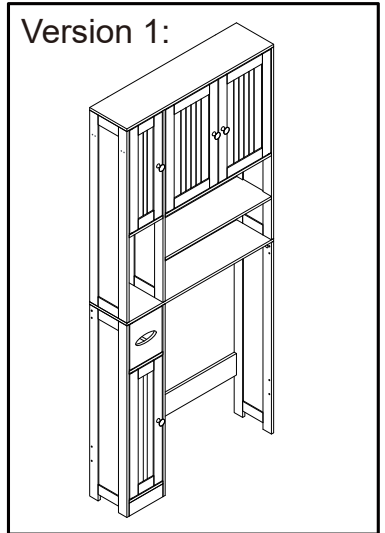
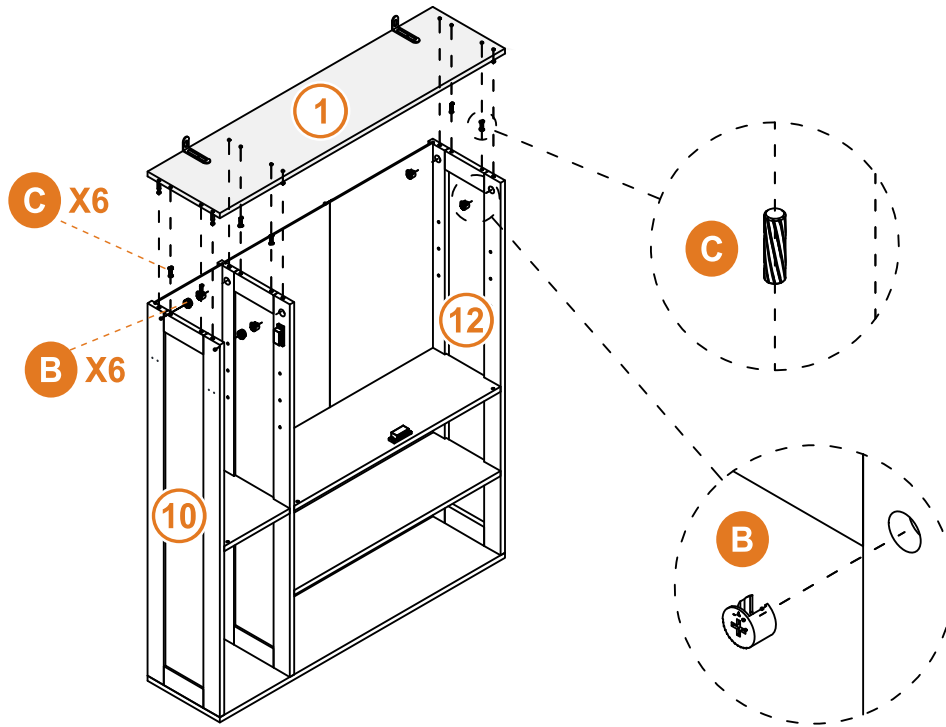
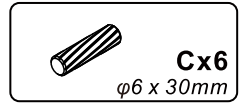
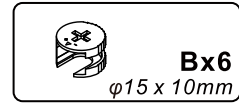

12

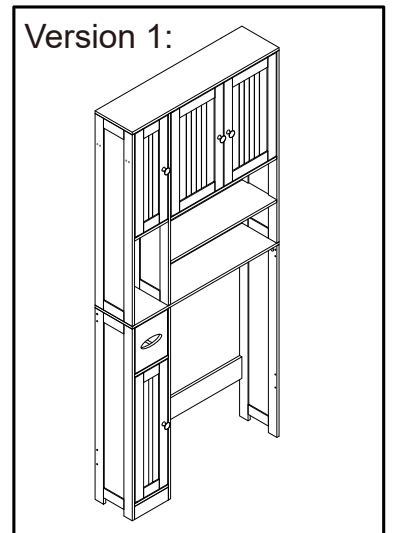
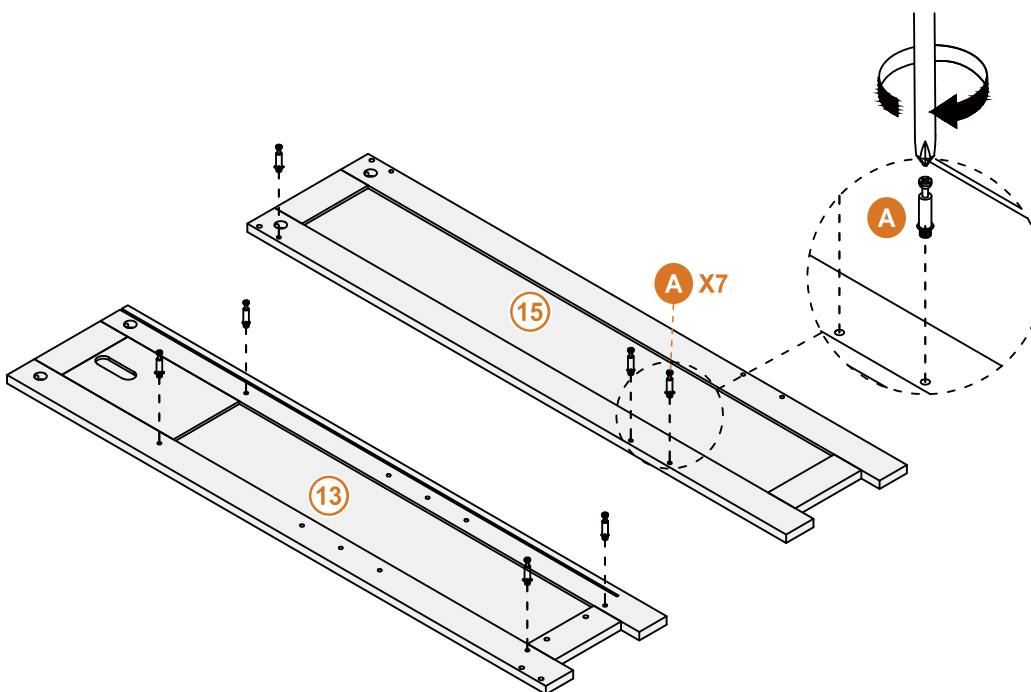
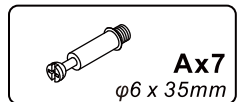
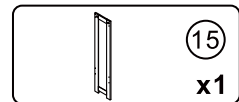
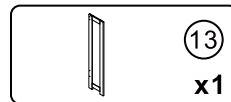

13

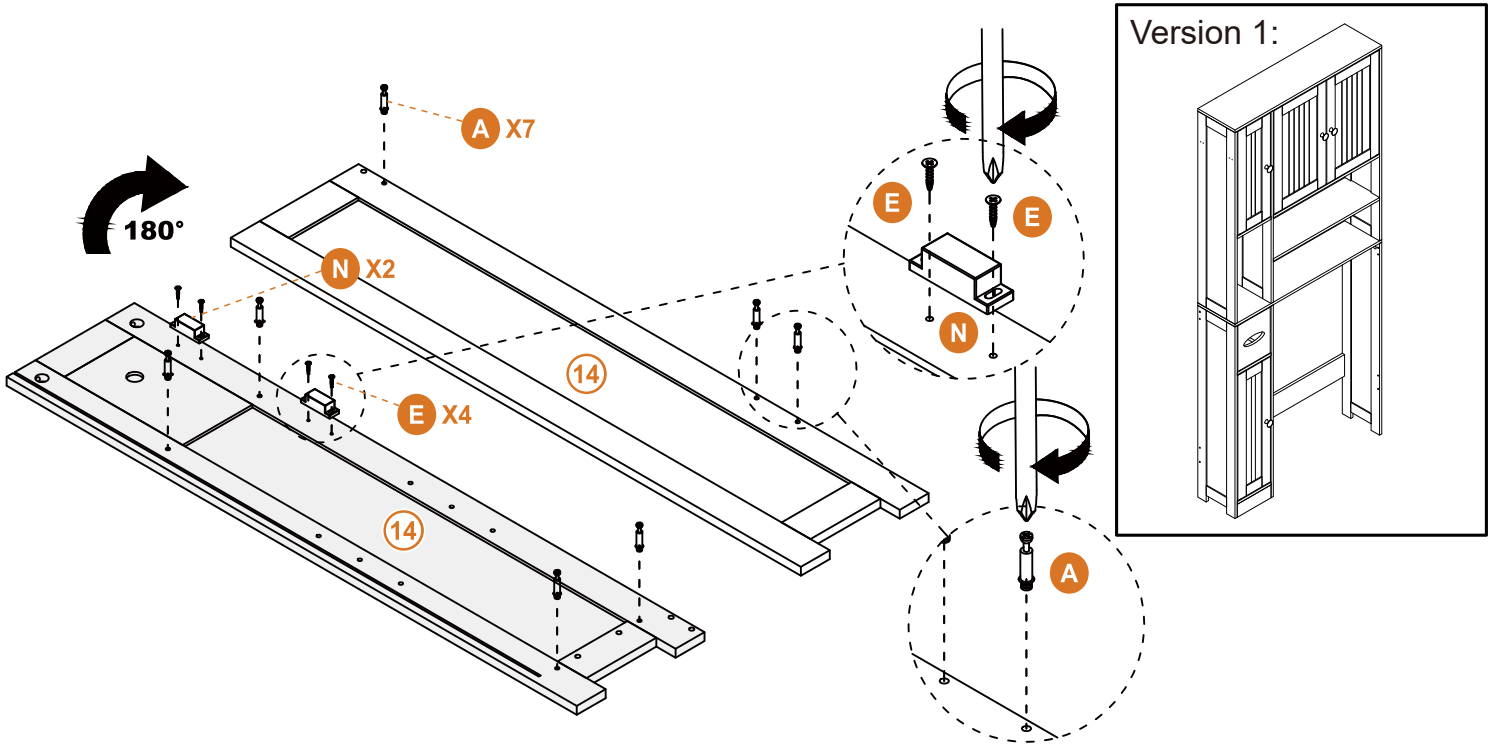
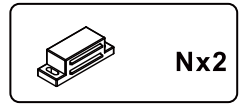
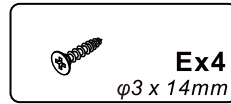
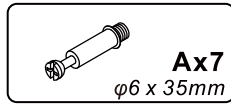
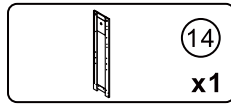

14

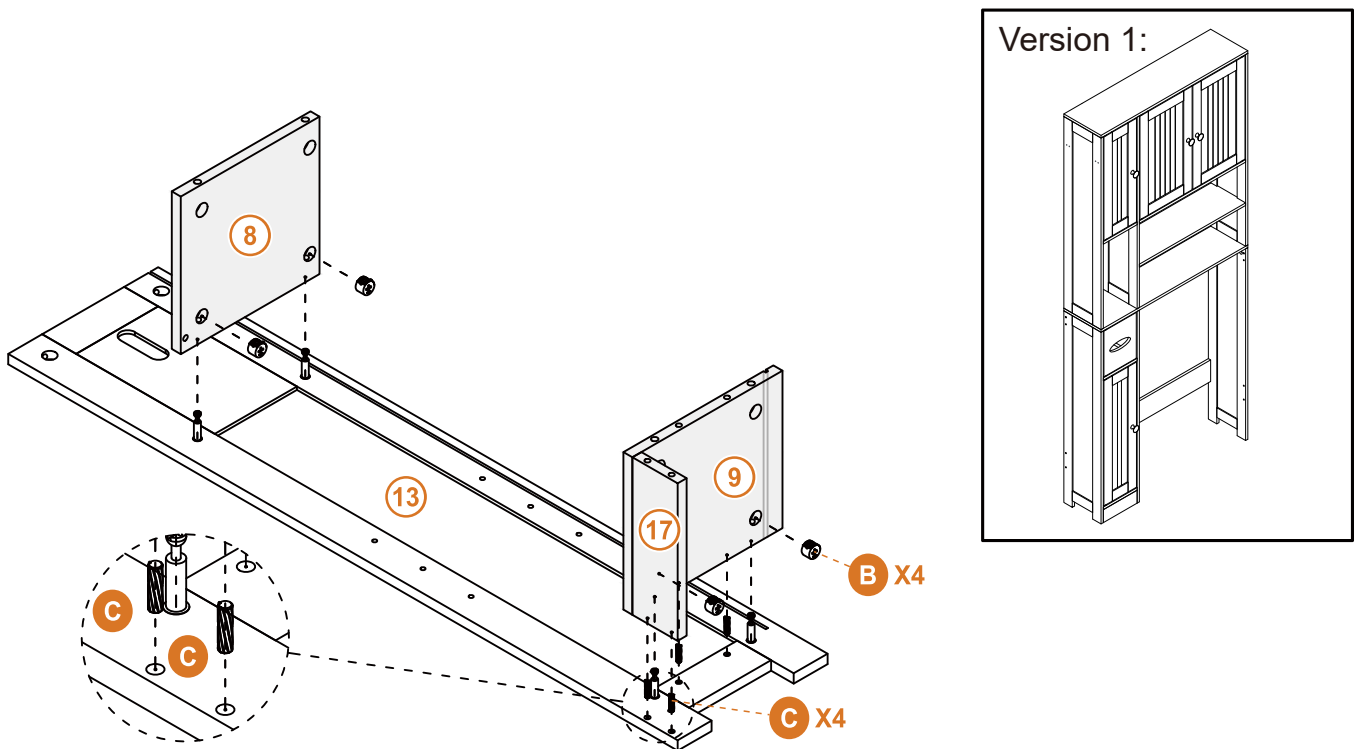
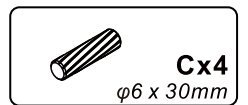
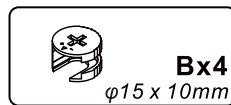
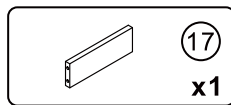
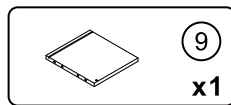
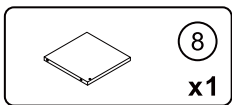

15

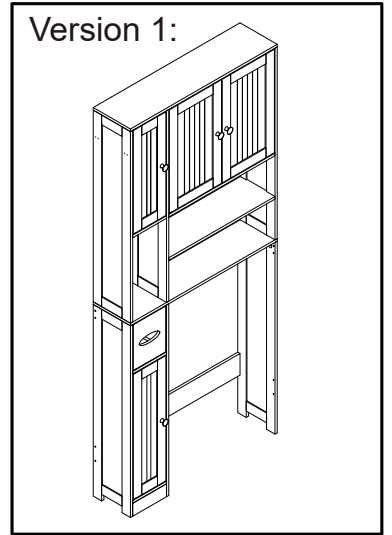
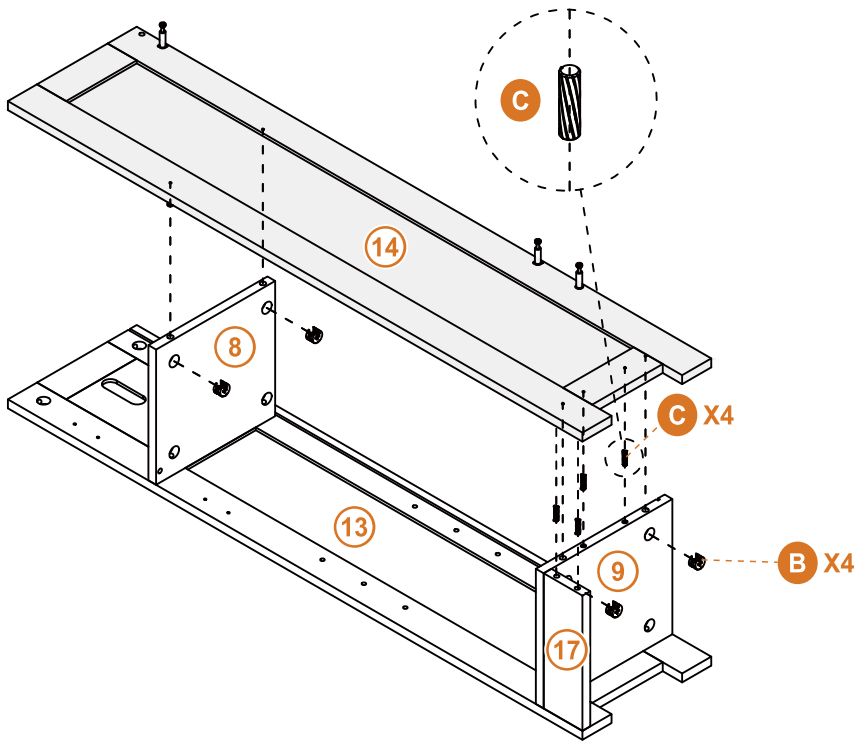
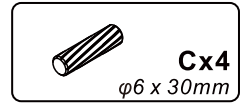
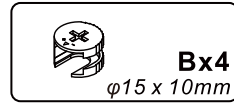

16

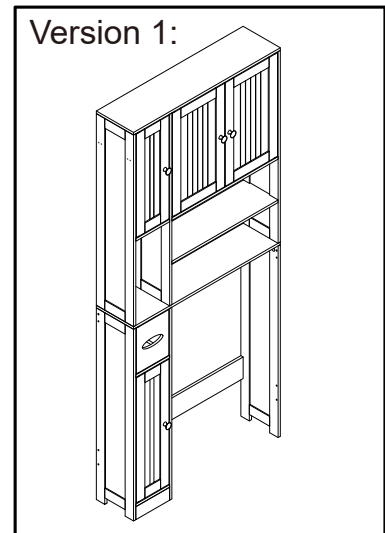
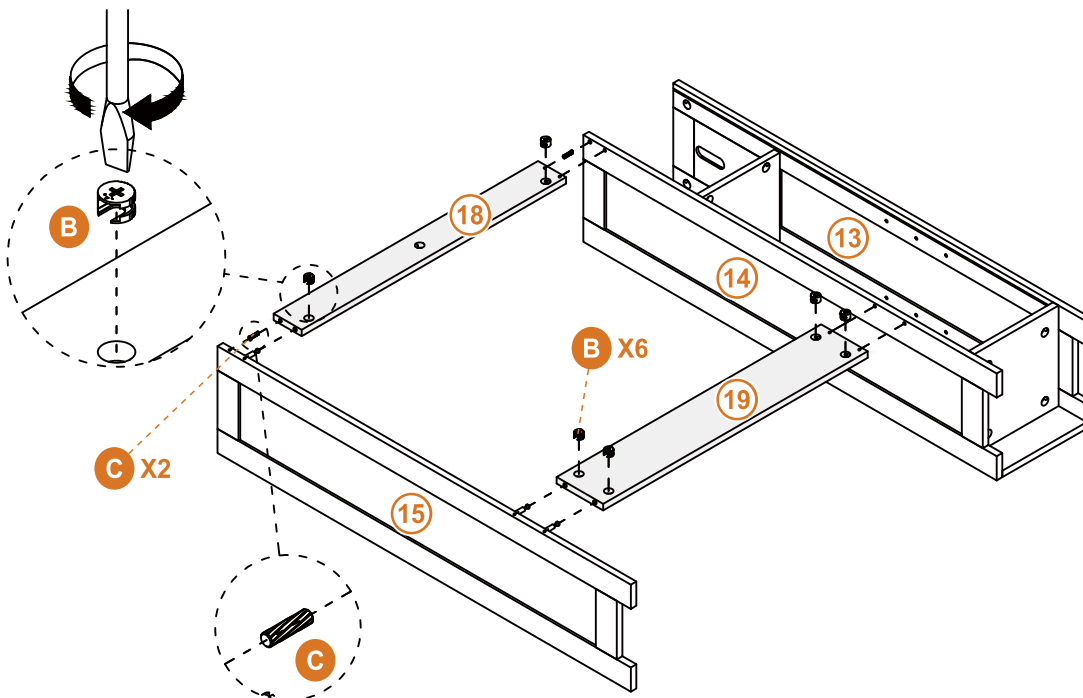
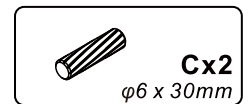
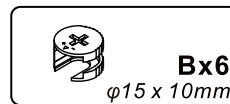
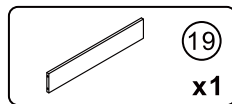
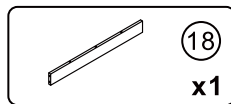

17

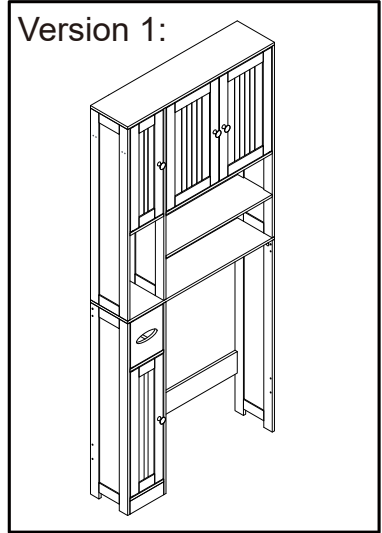
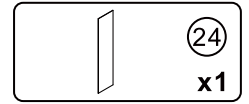
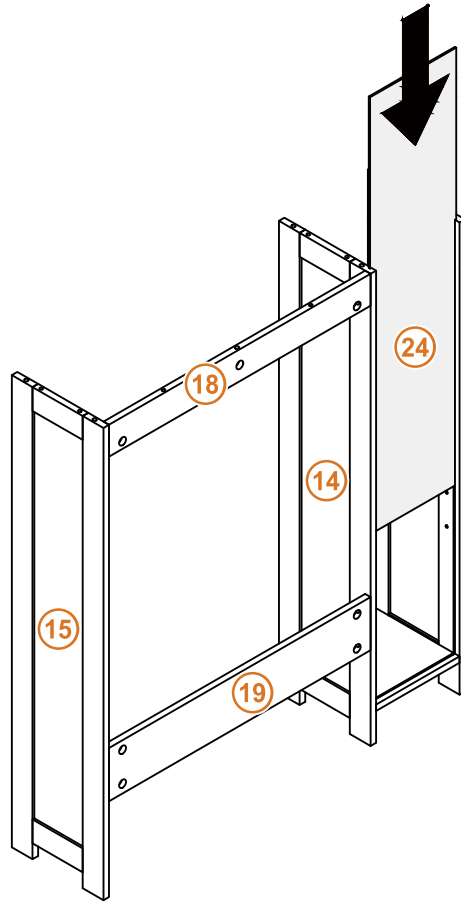

18

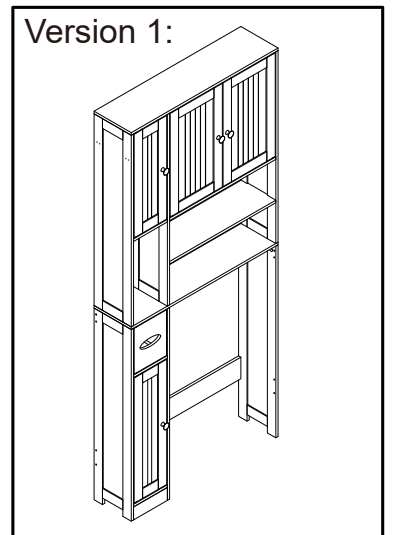
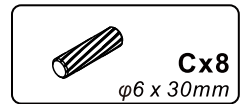
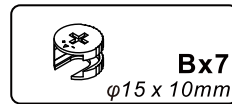
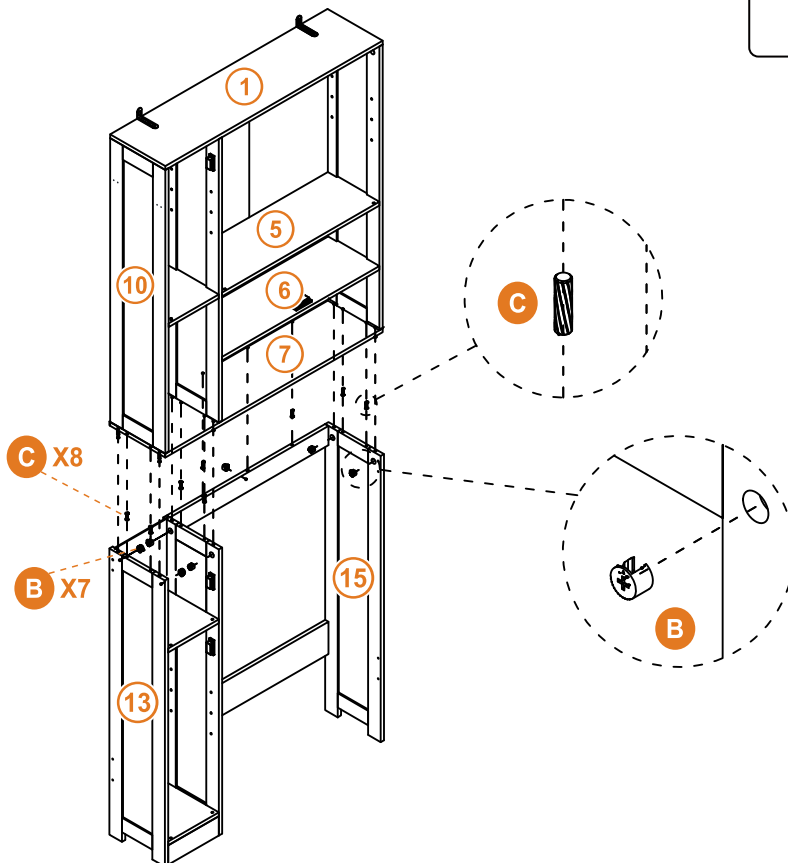

19



Ex16
φ3 x 14mm



Fx16

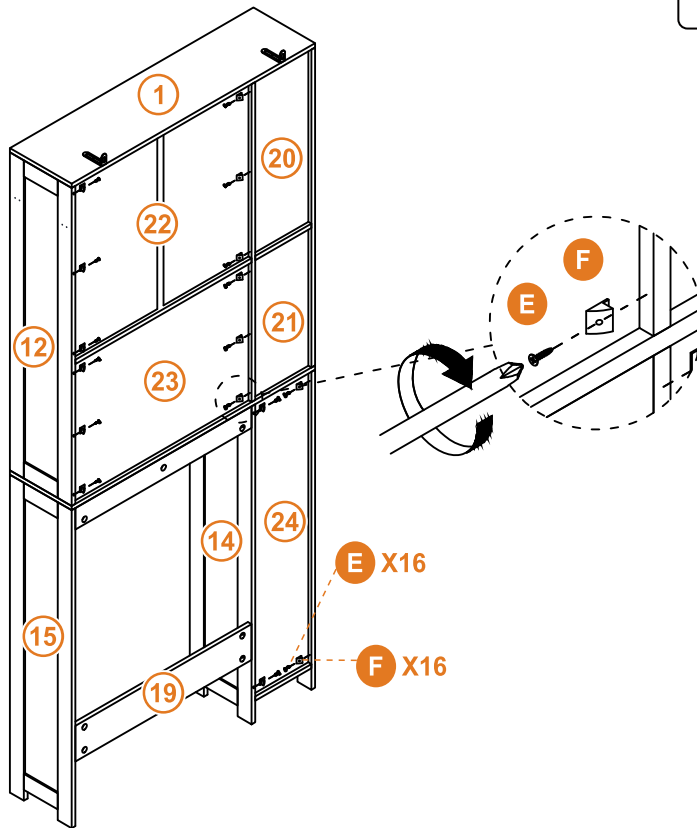

Version 1:

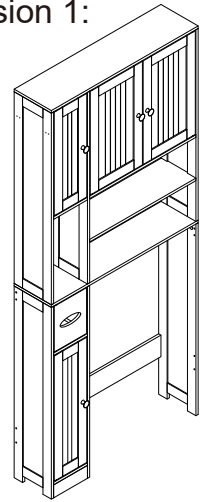

20



Dx2
φ4 x 40mm



Kx2

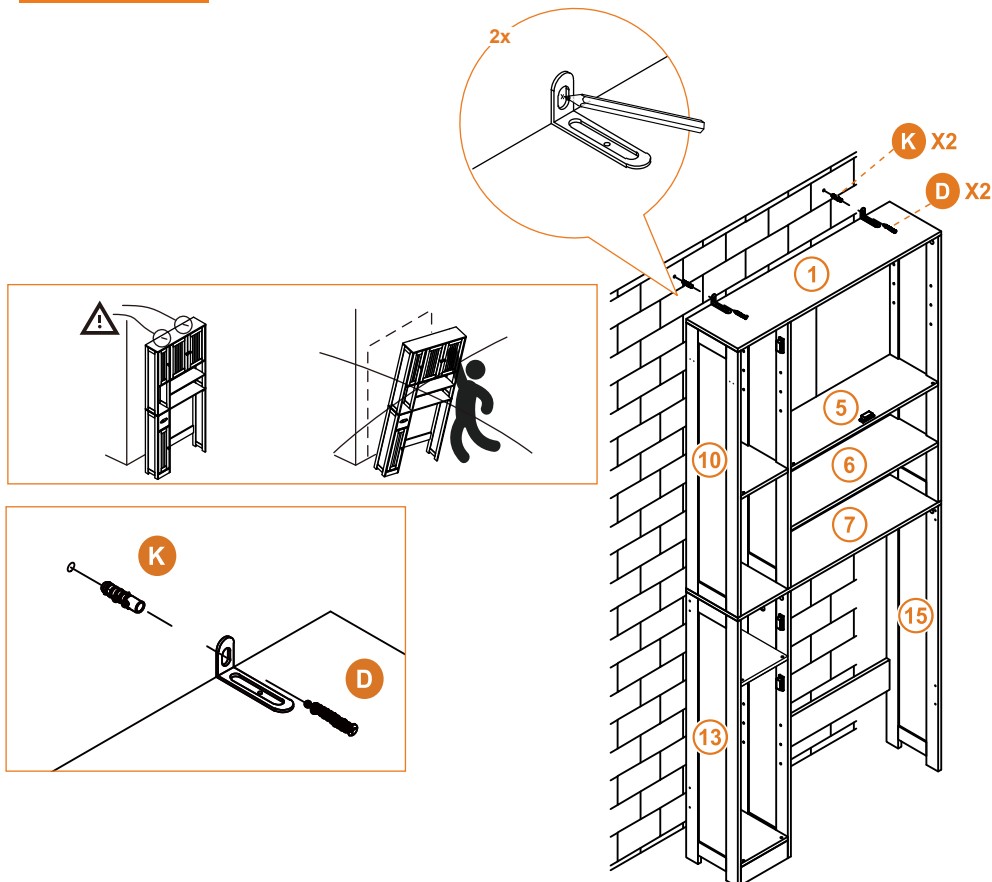

Version 1:

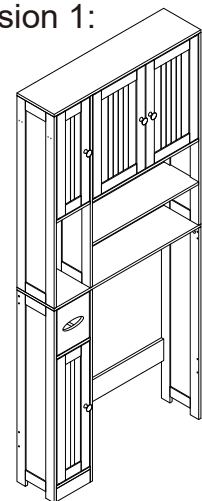

21

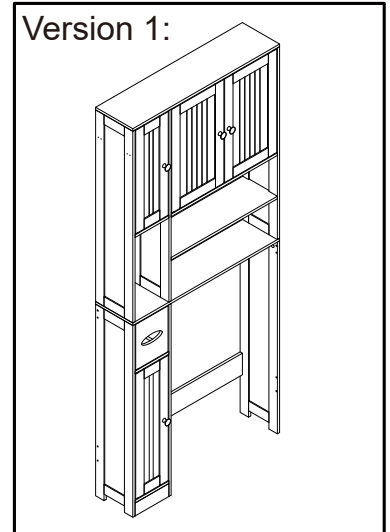
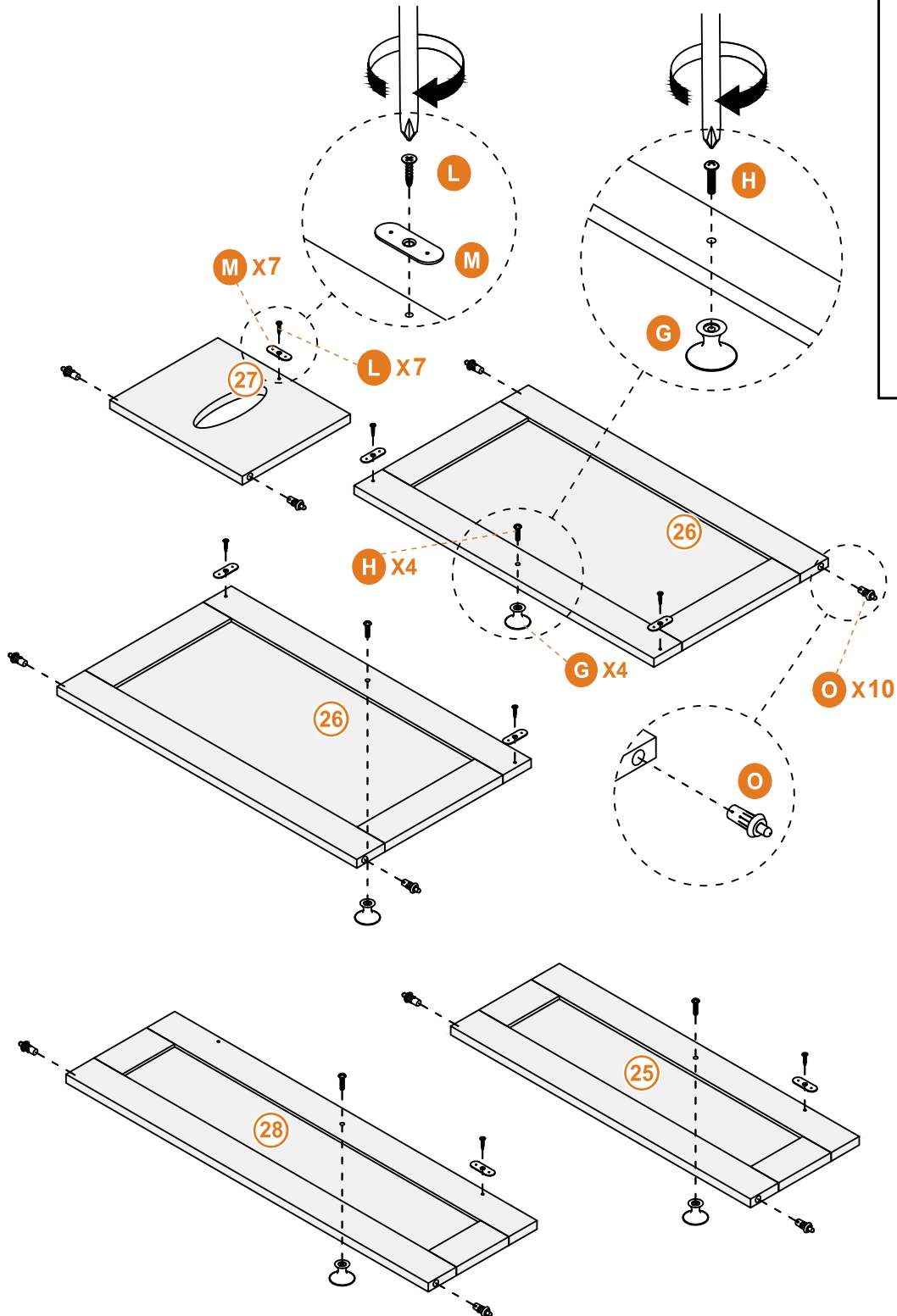
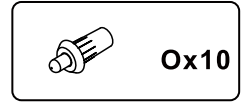
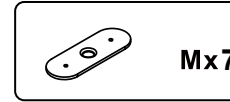
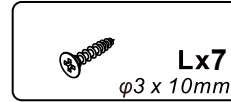
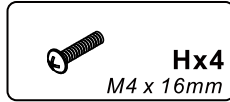
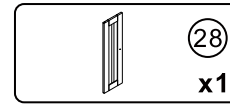
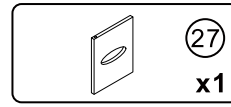
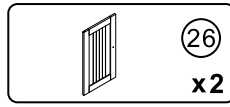
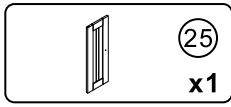

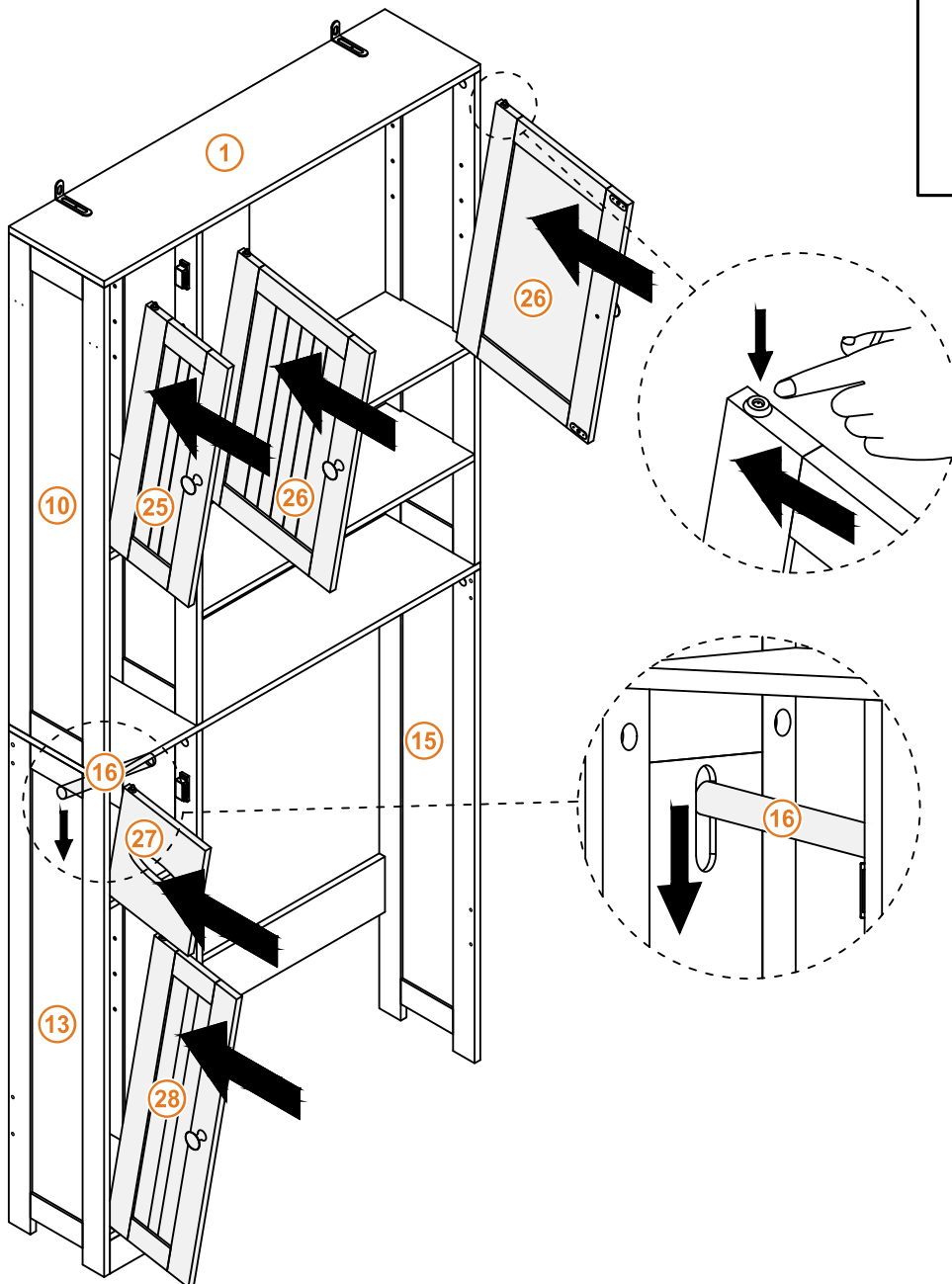
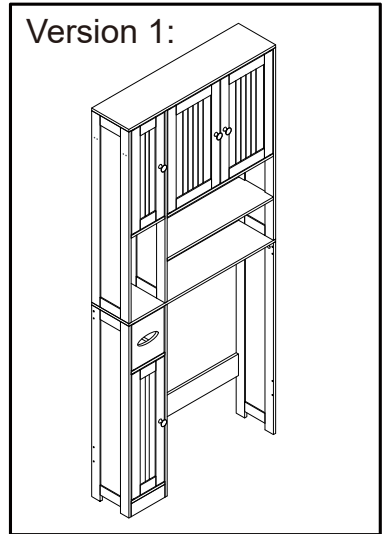
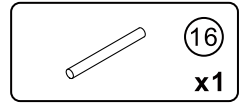

23

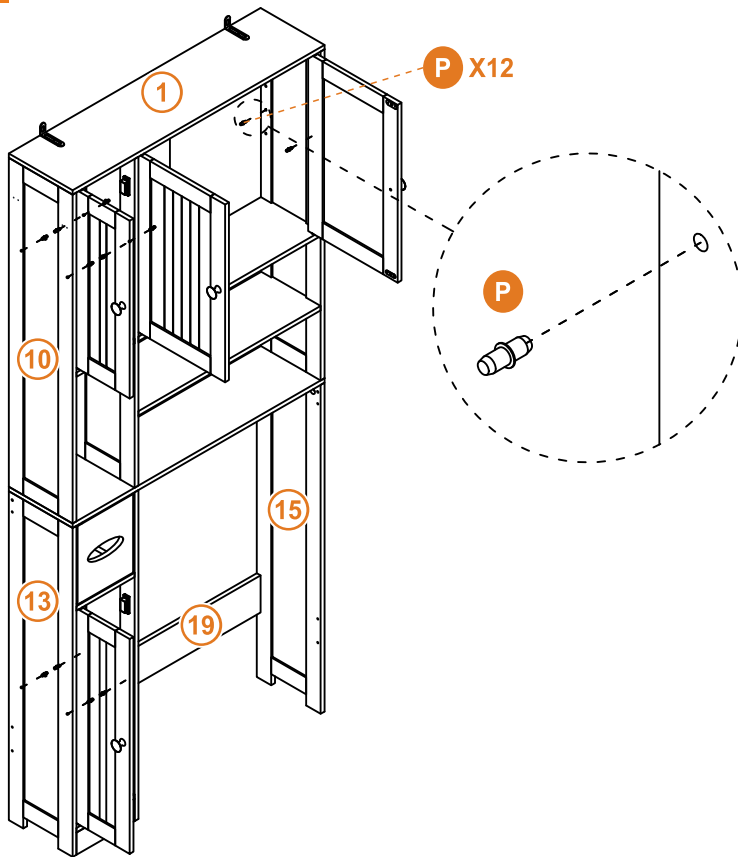

Px12

Version 1:

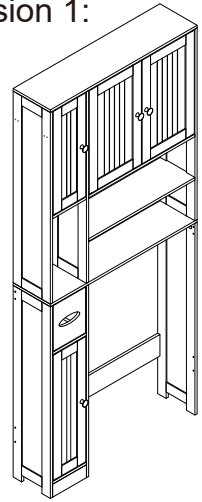

24

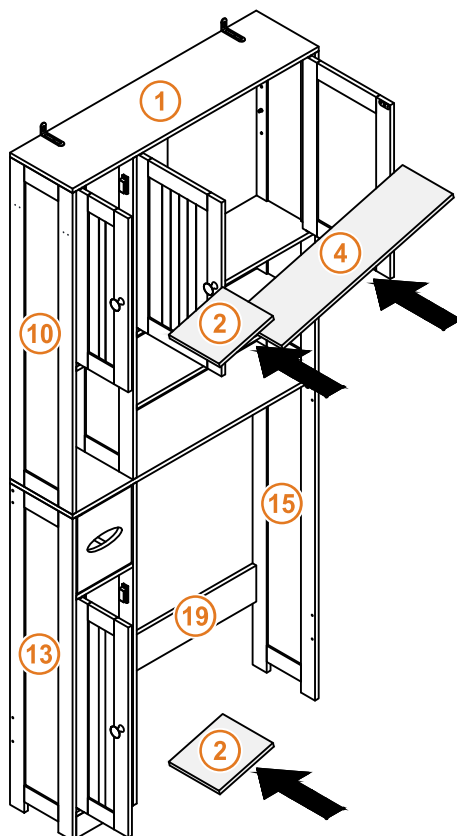

2
x2

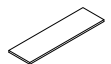

4
x1

Version 1:

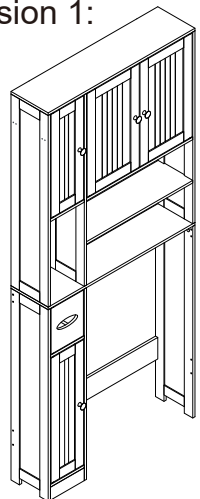

25

Version 1:

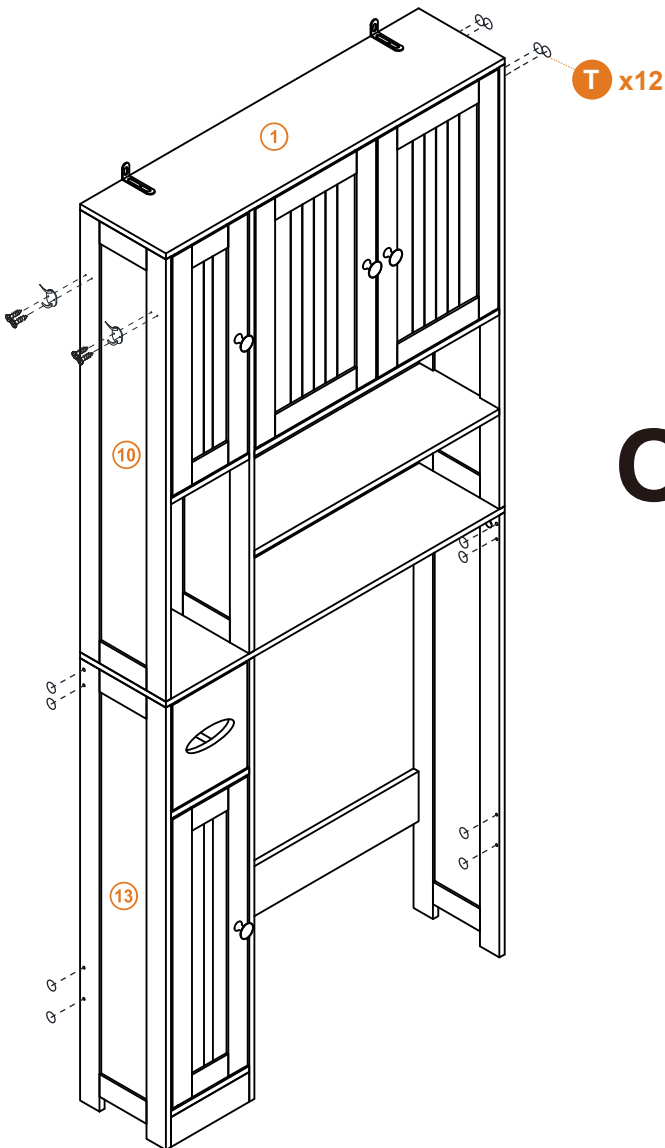
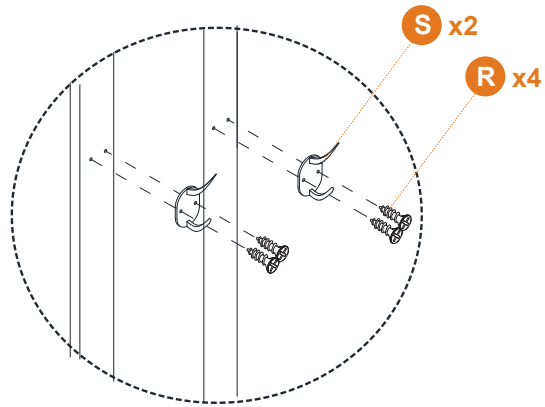
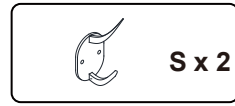
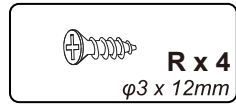
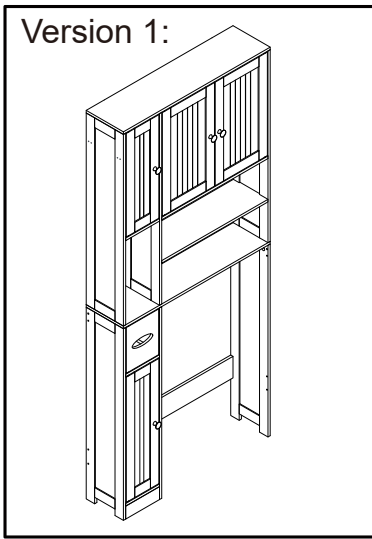

OR

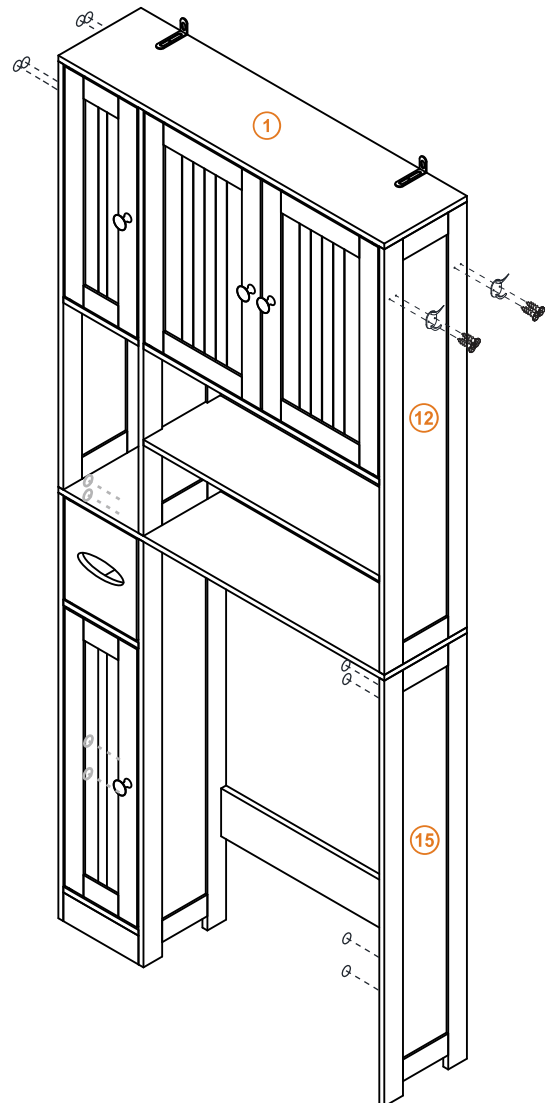

26

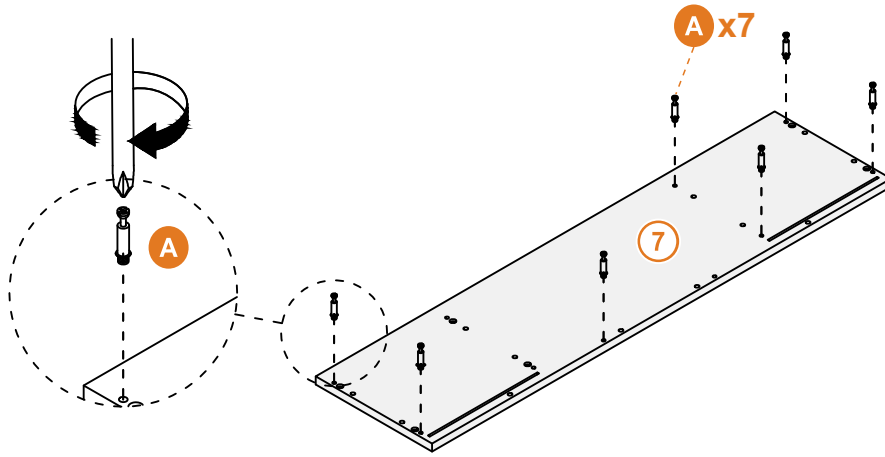
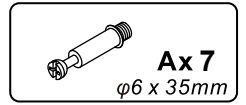
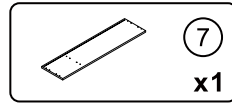

Version 2:

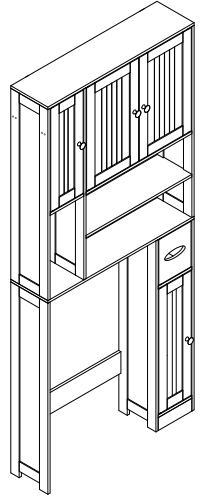

27

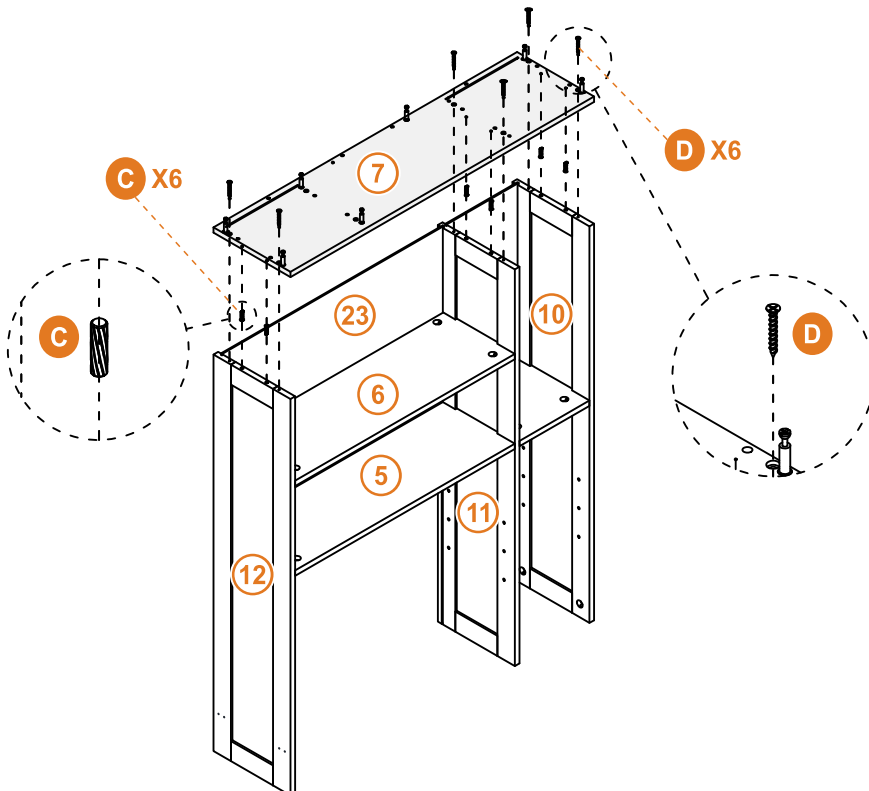
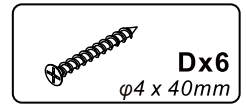
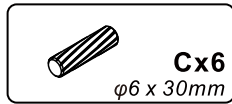

Version 2:

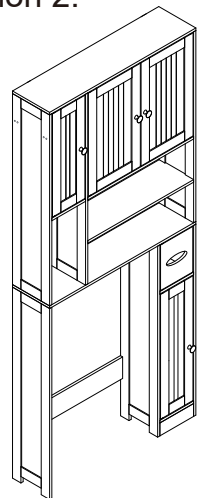

28

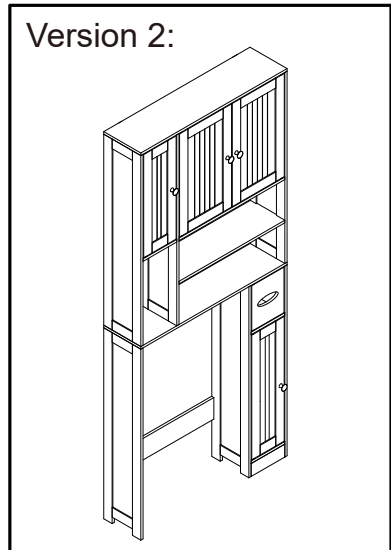
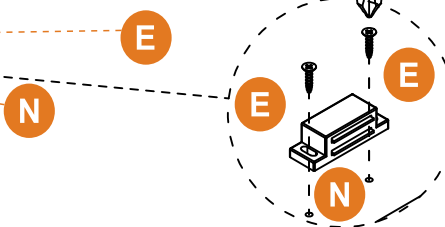
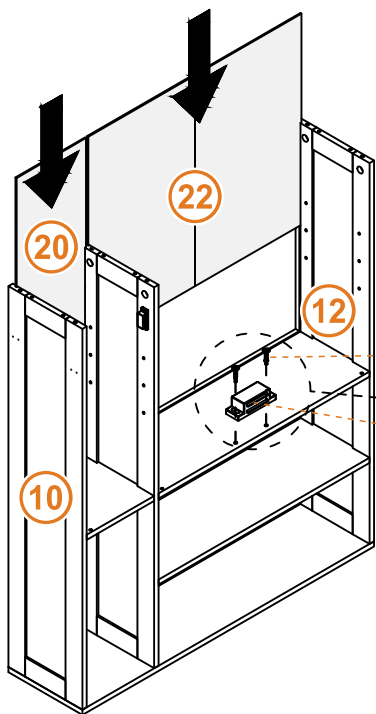
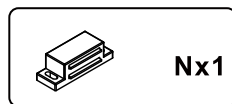
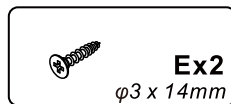
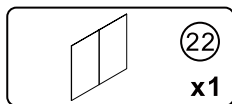
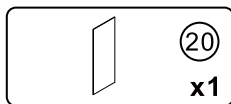

29

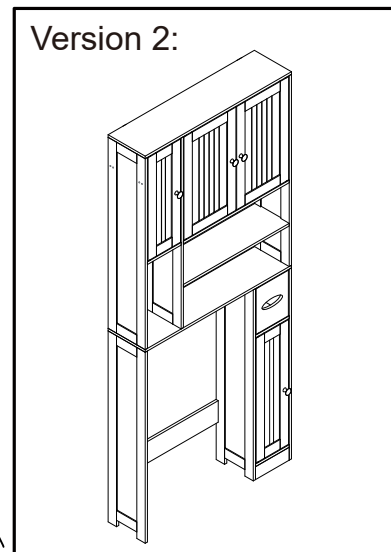
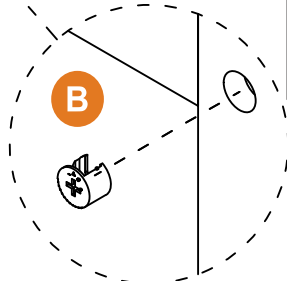
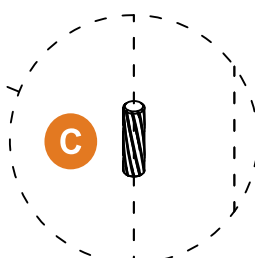
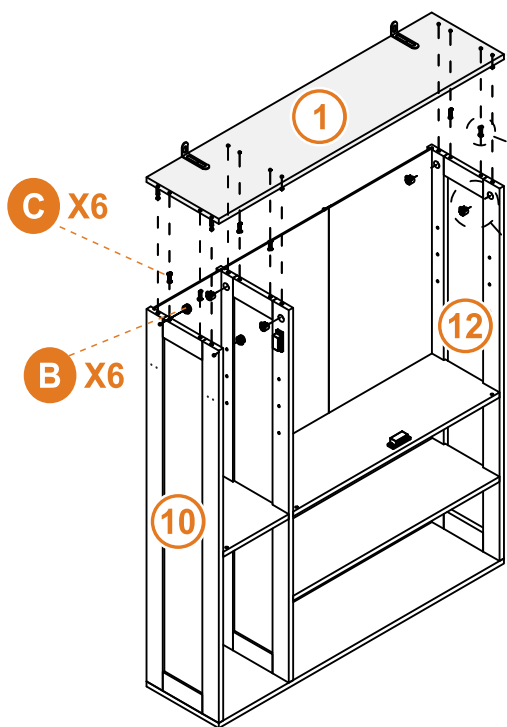
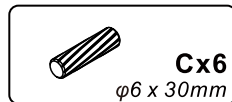
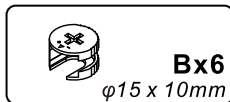

30

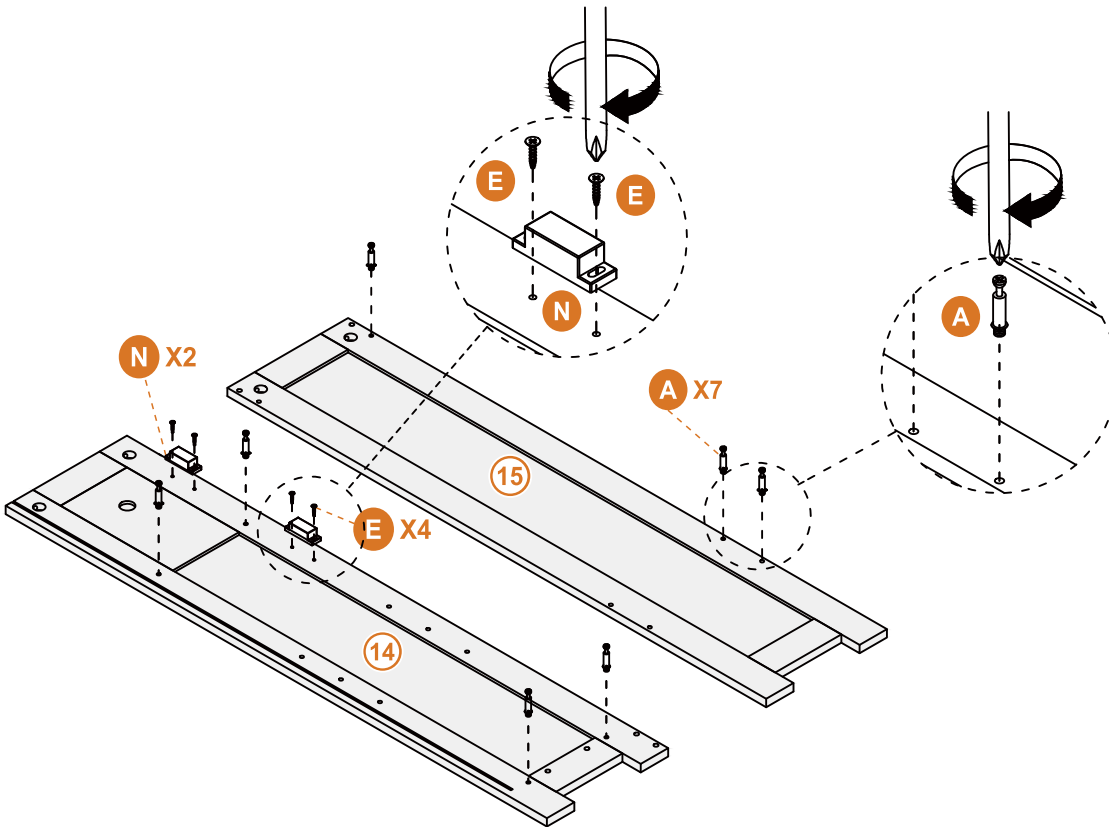
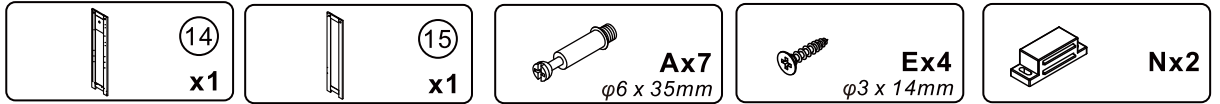

Version 2:

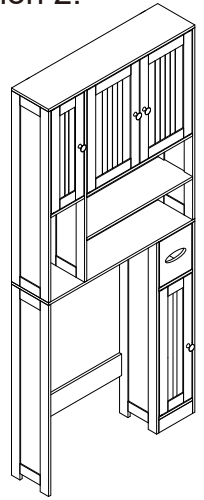

31

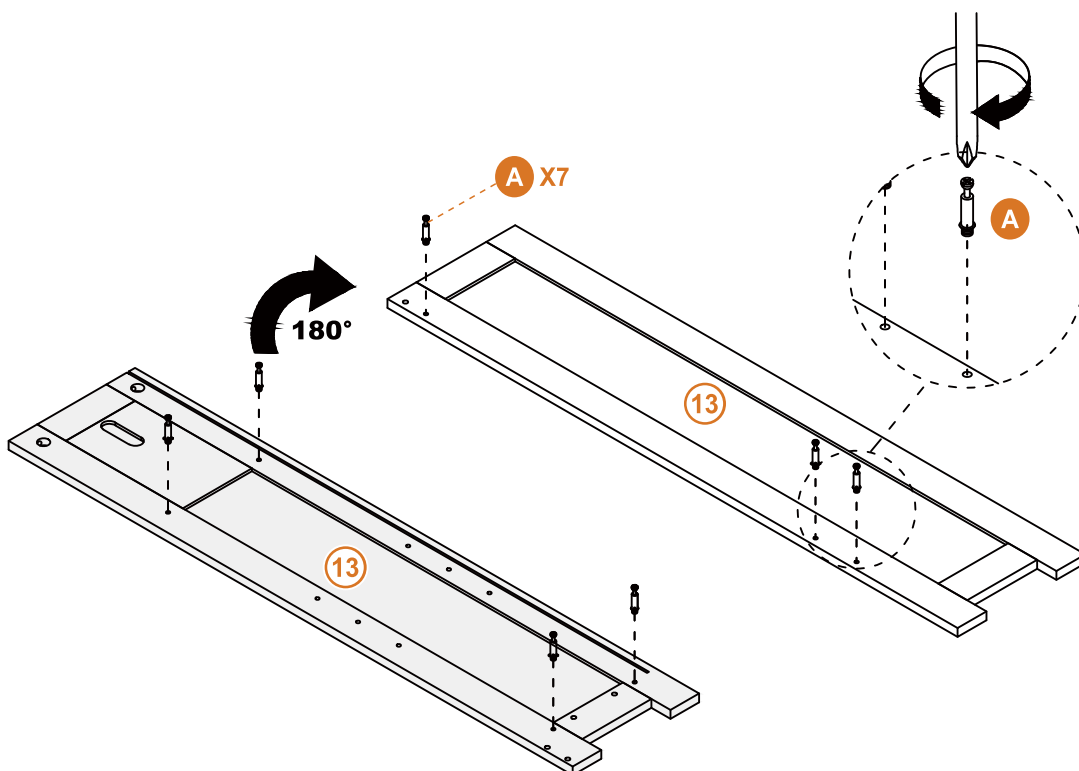
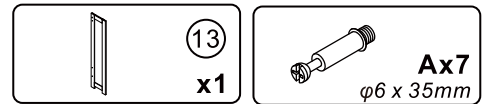

Version 2:

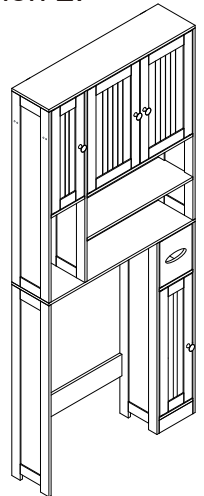

32

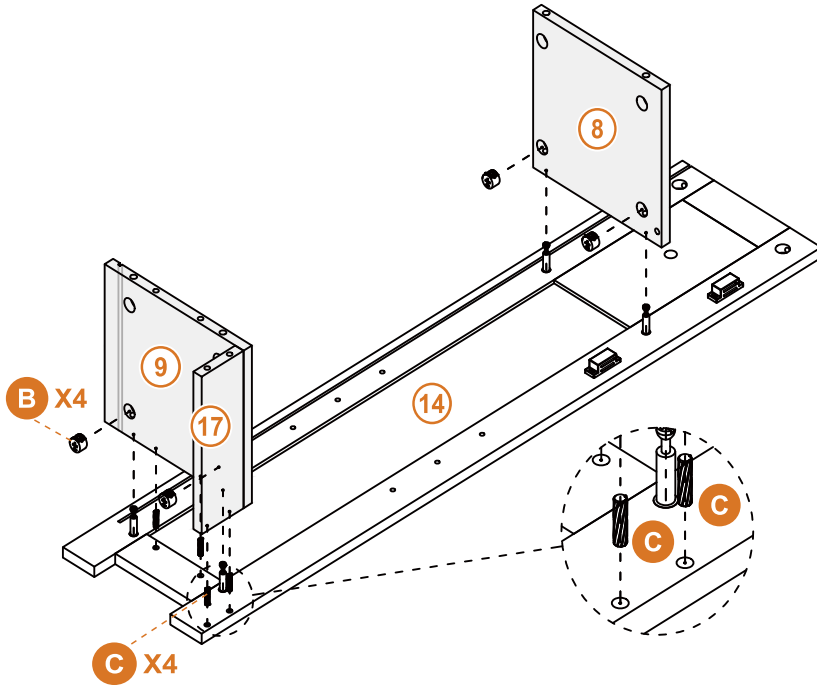
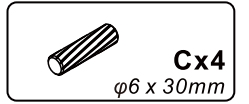
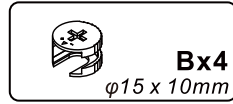
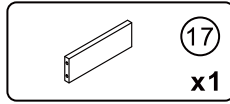
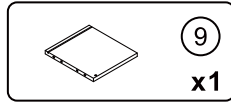
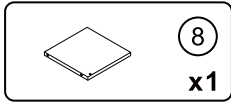

Version 2:

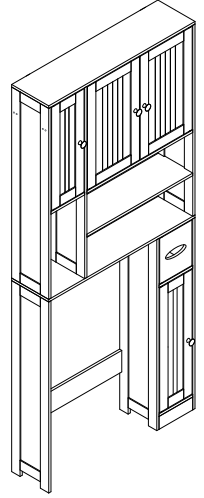

33

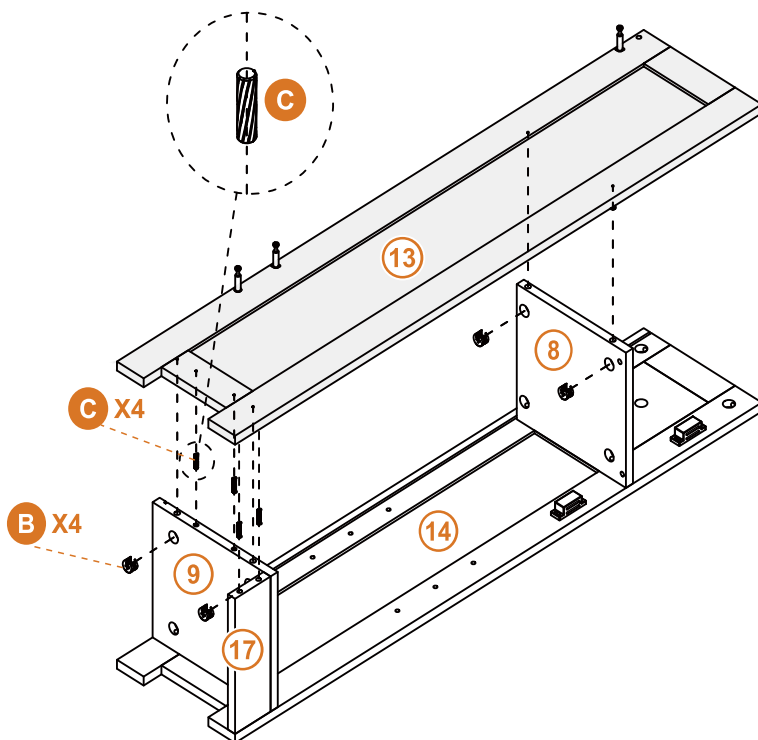
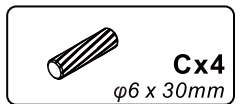
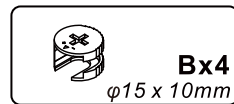

Version 2:

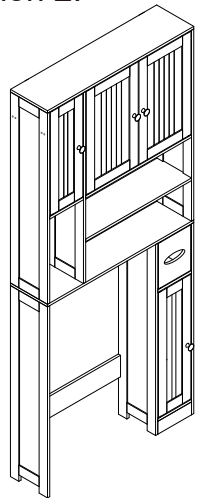

34

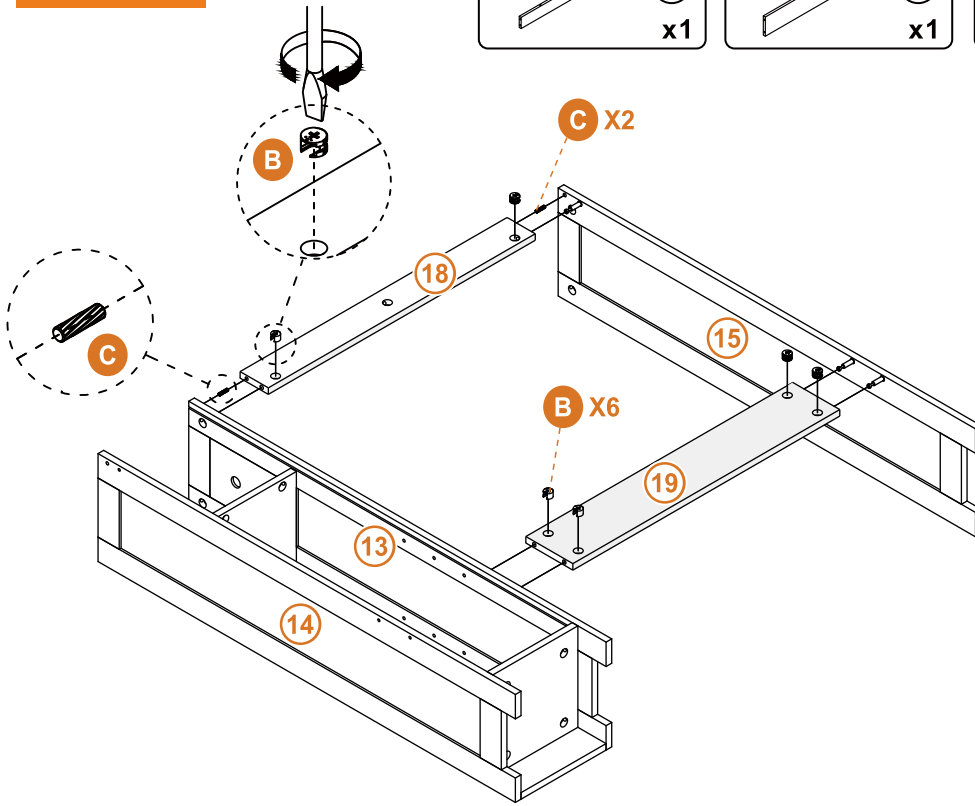
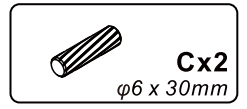
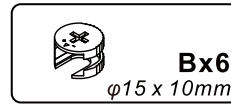
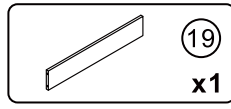
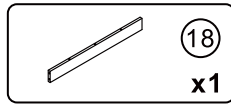

Version 2:

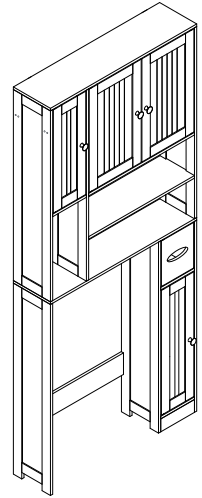

35

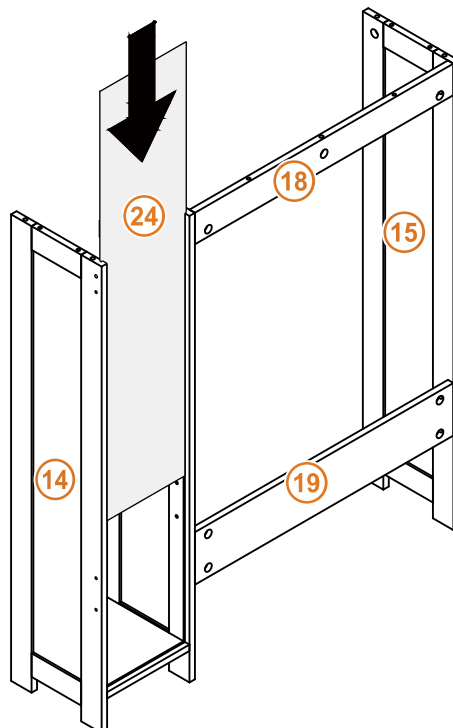
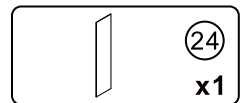

Version 2:

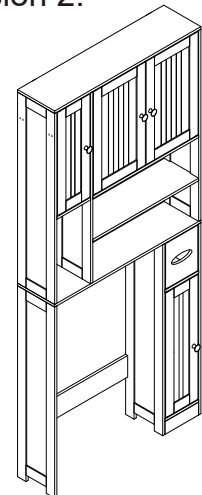

36

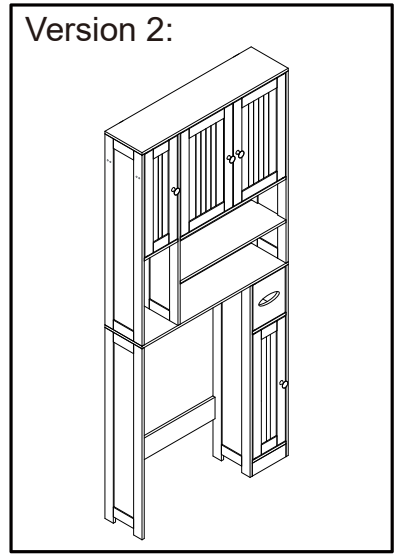
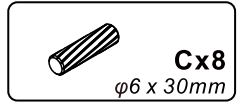
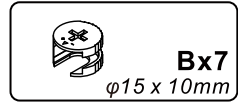
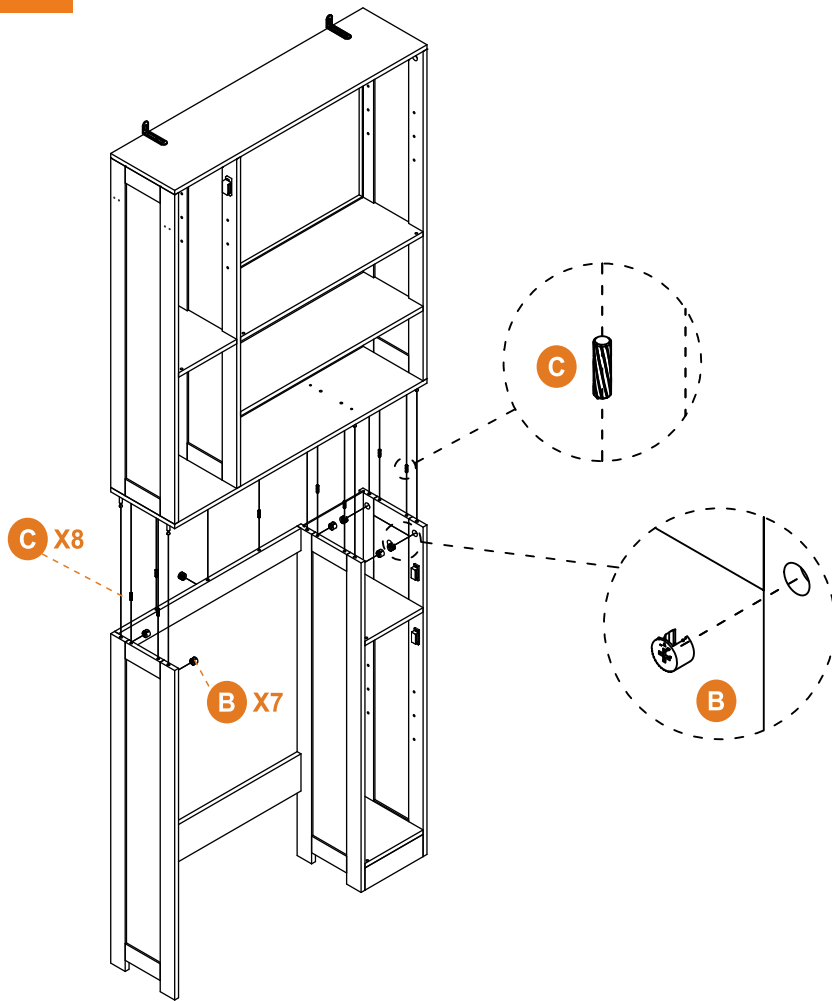

37

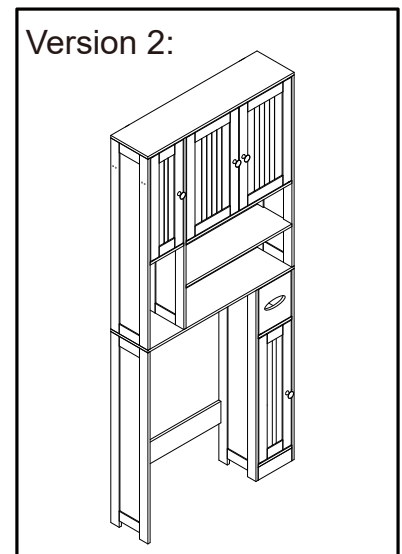
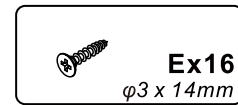
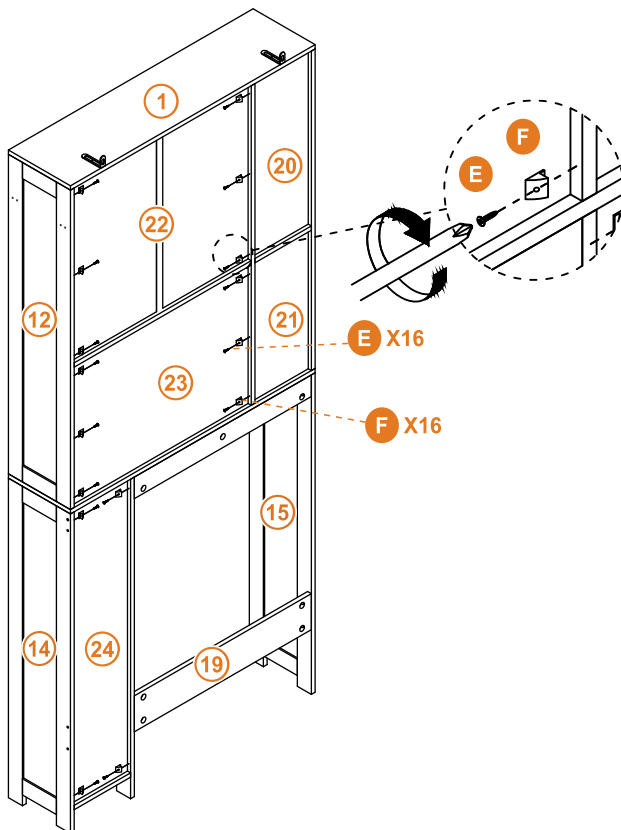

38

Dx2
φ4 x 40mm

Kx2

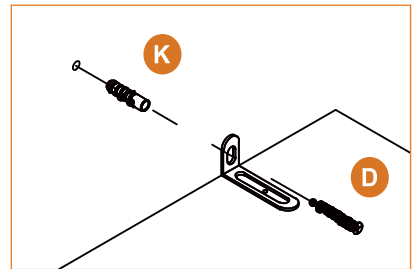
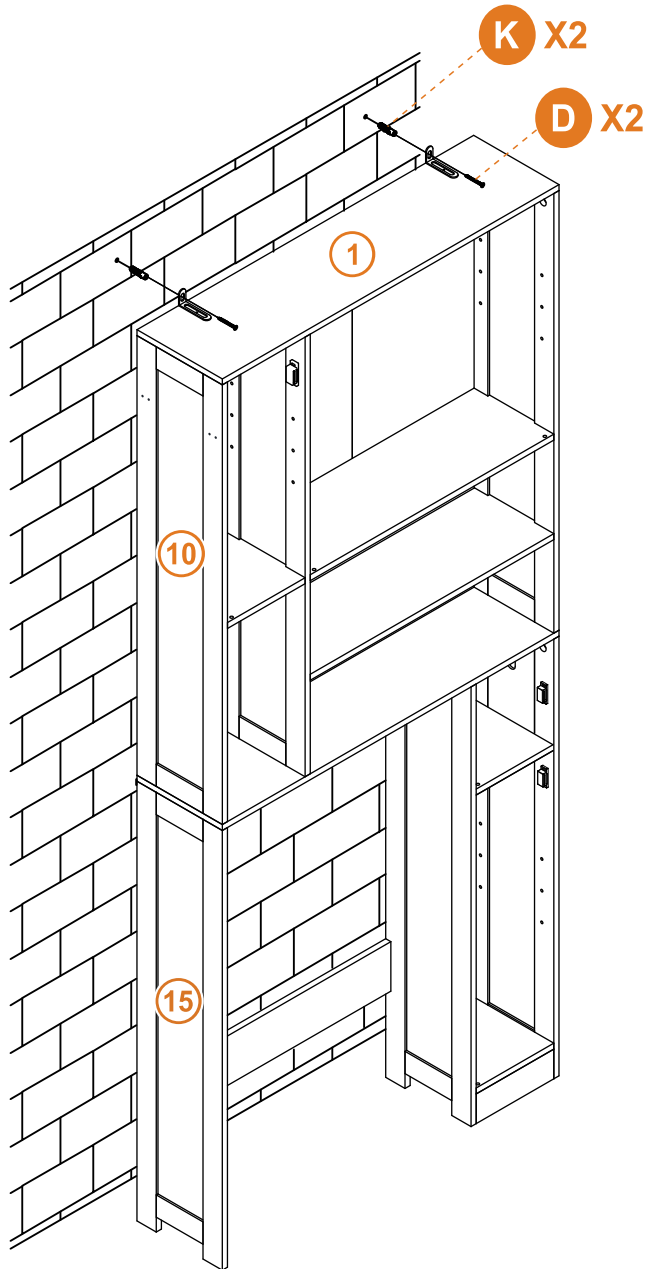
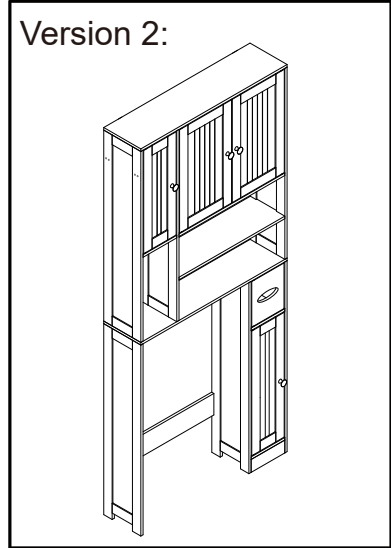
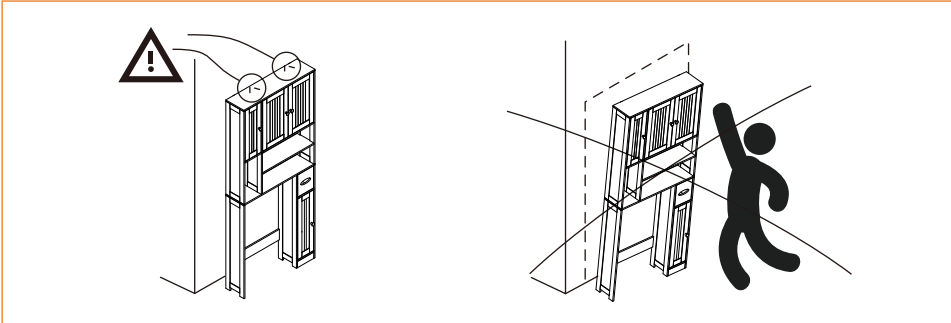

39

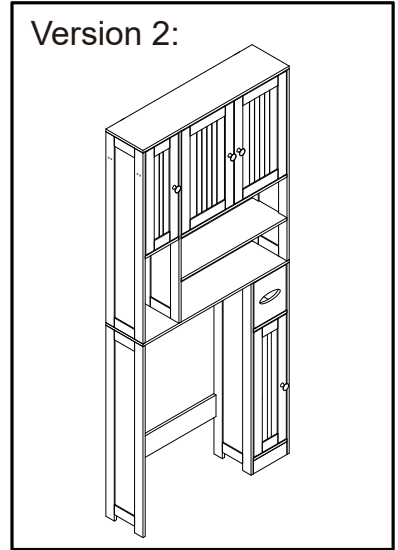
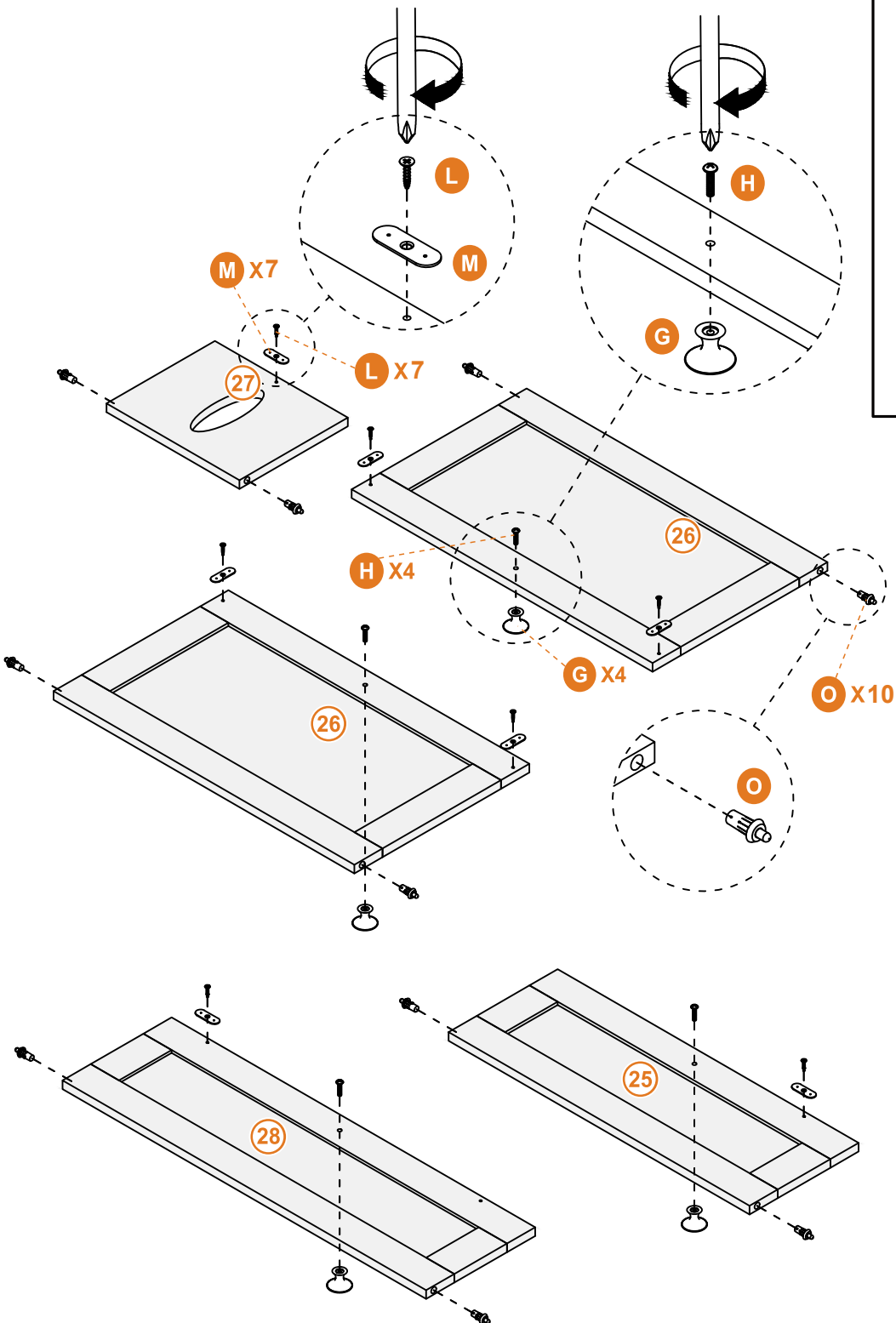
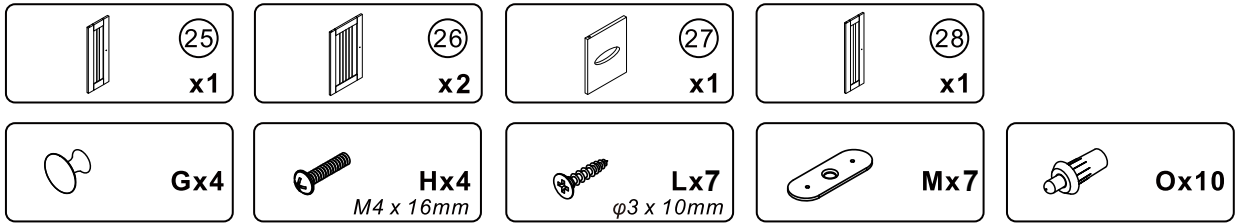

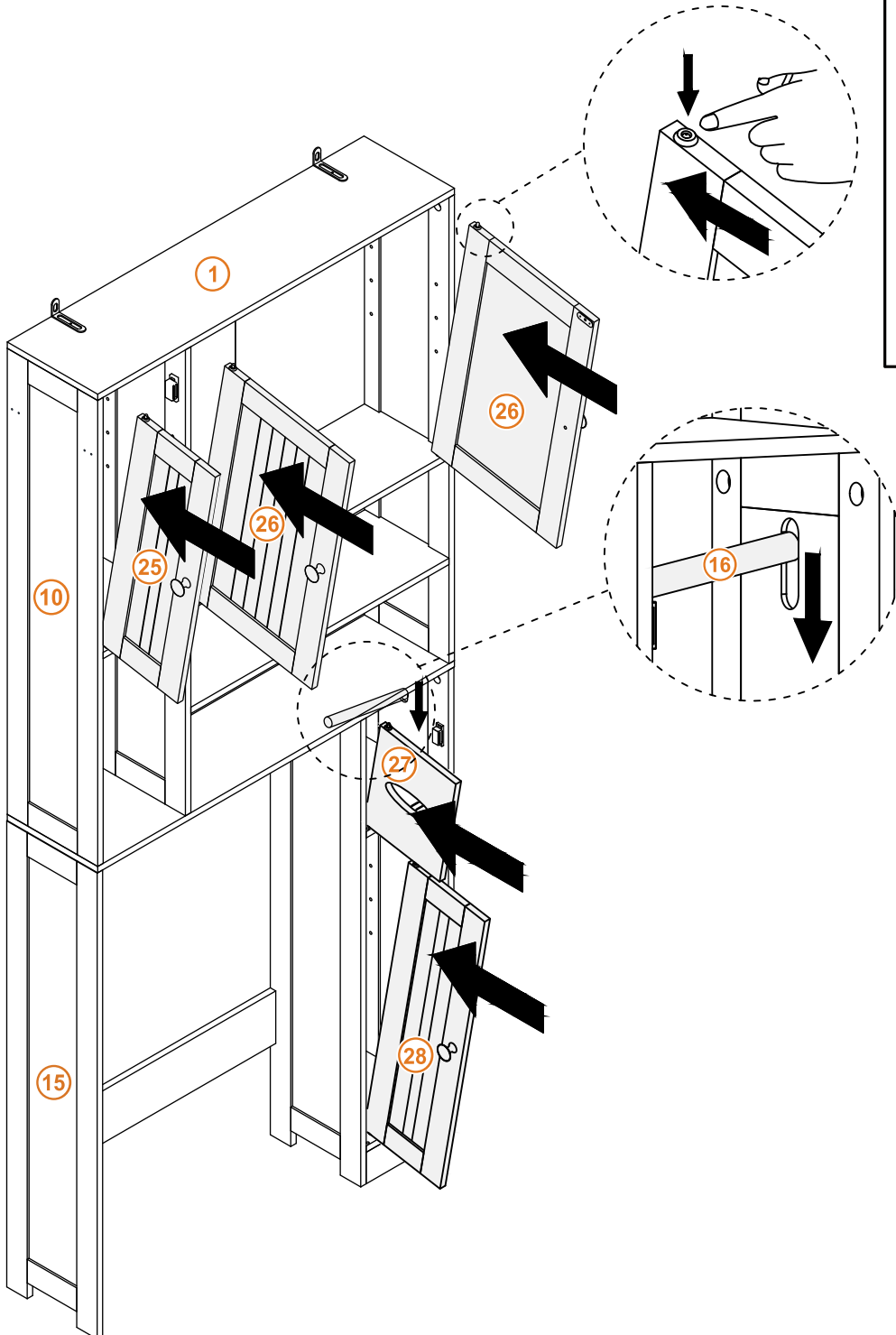
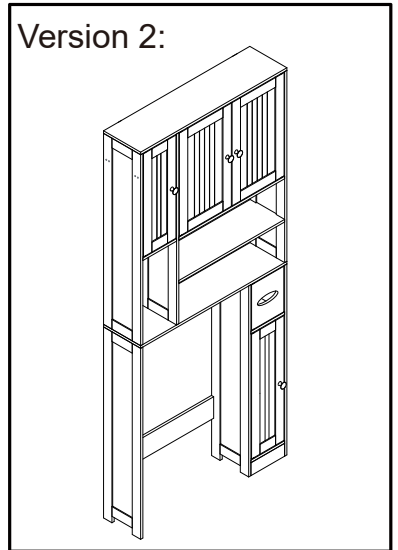
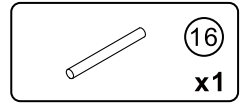

41

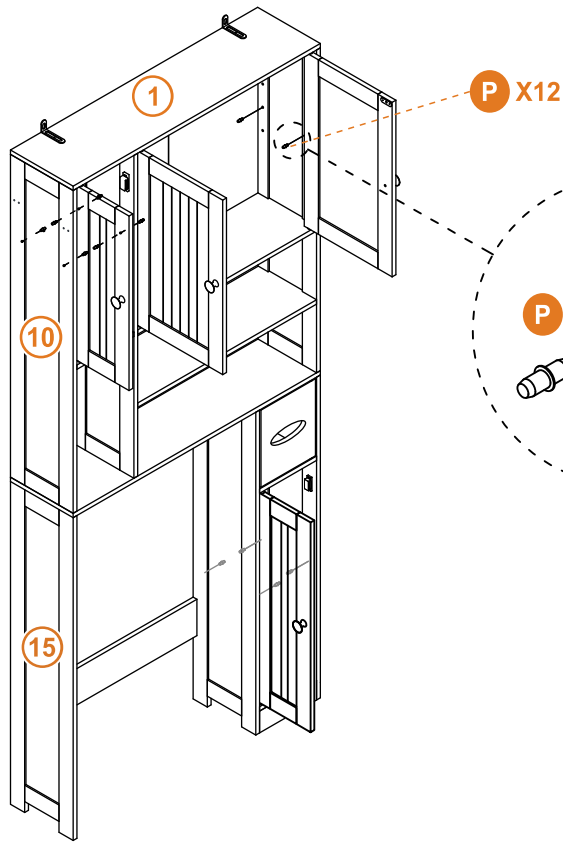

P x12

Version 2:

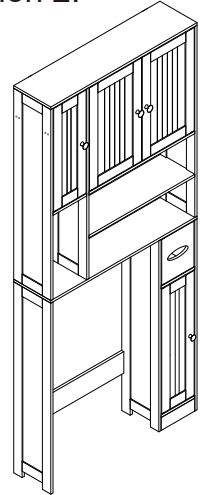

42

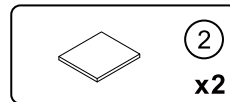
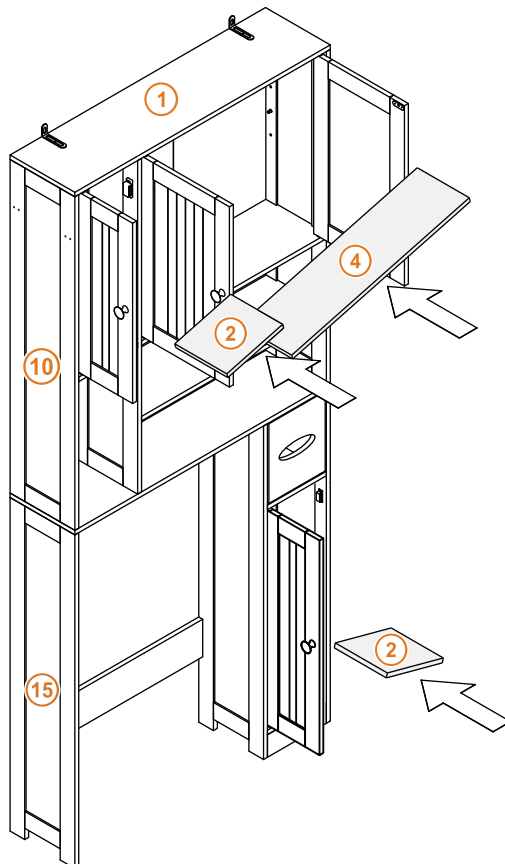

2

x2

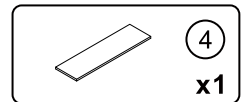

4

x1

Version 2:

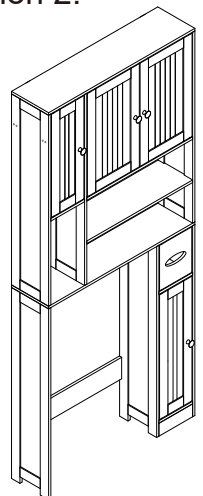

42

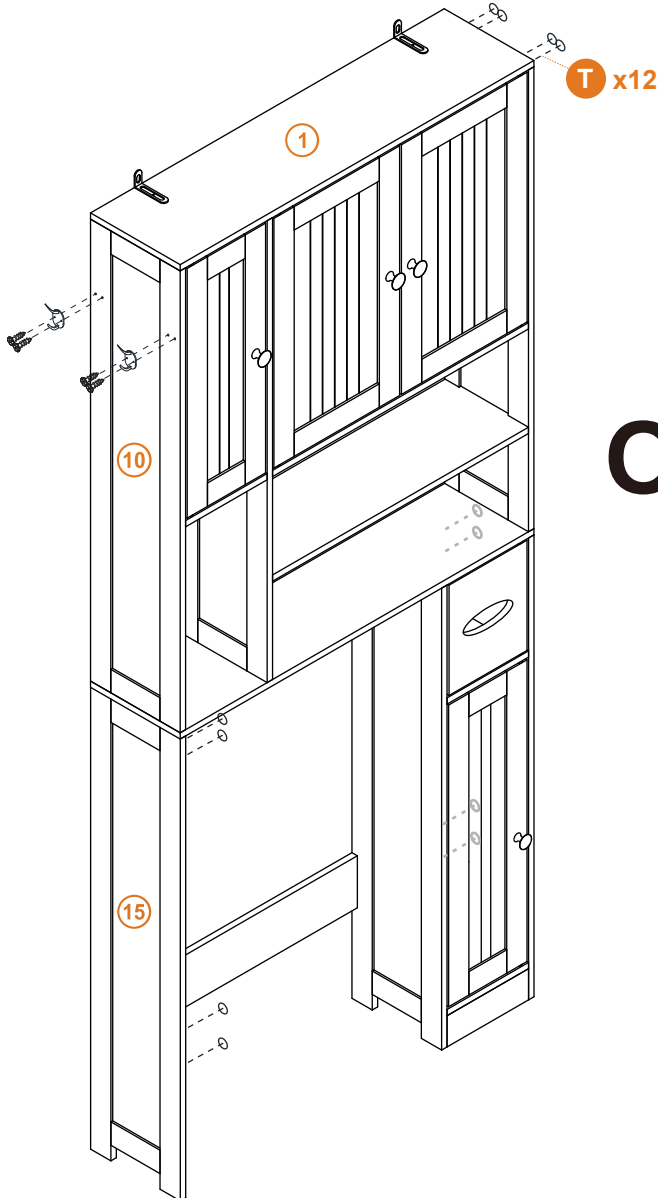
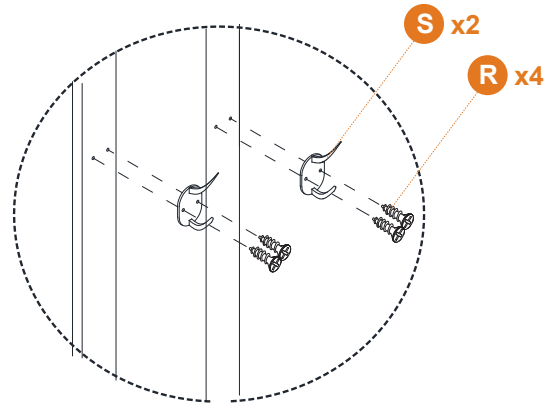
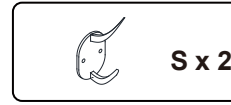
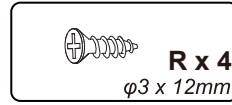
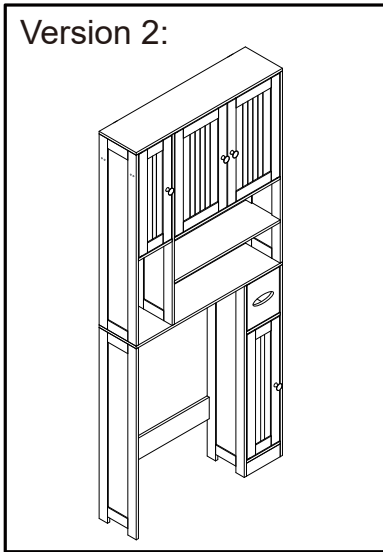

OR

