

Assembly Instructions

Caution : You must read this before you proceed

Please look in the Seat Panel for hardware packs

BENCH

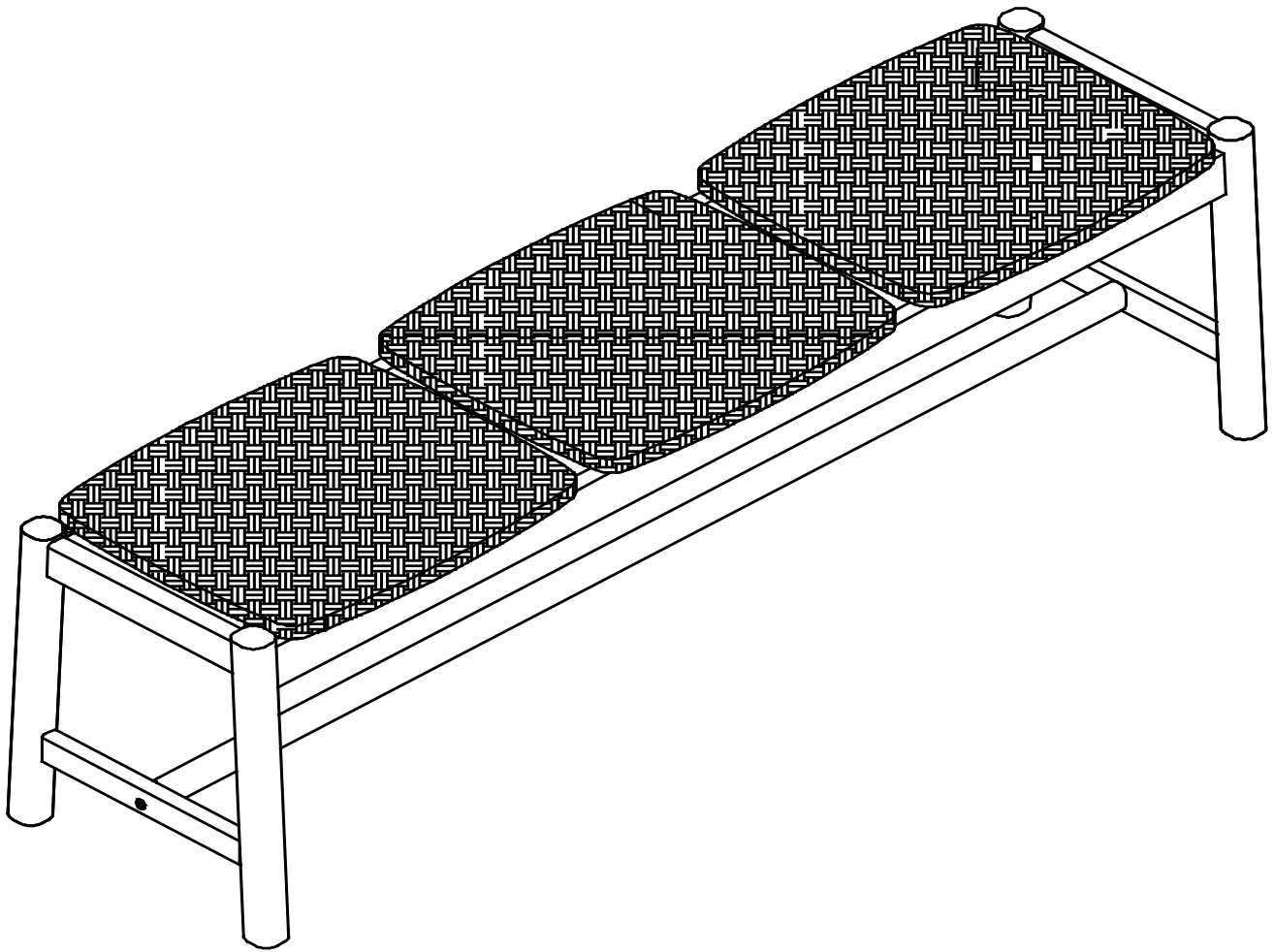



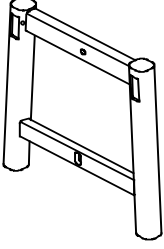
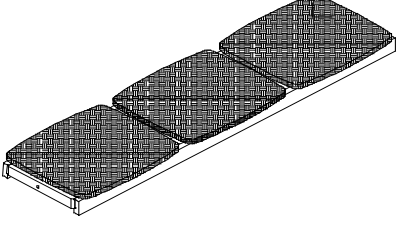
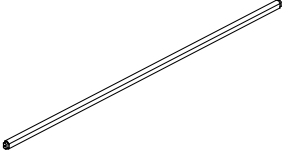

CAUTION : This Bench is NOT a TOY. Keep your child / children at bay in the process of assembly.
For turning the Bench and to prevent possible damage to it, 02 persons may be needed to execute this action

Parts List

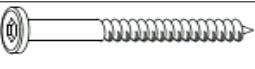
| Label | Picture | Description | QTY |
|-------|---|-------------|-----|
| A |  | Leg Panel | 2 |
| B |  | Seat Panel | 1 |
| C |  | Support Bar | 1 |

Hardware

| No. | Picture | Description | Qty |
|-----|---|----------------------------|-----|
| ① |  | Bolts (M6x40mm) | 3 |
| ② |  | Screw (M6x60mm) | 3 |
| ③ |  | Bolt (M6x90mm) | 5 |
| ④ |  | Washer (6.5/20 x 2mm) | 7 |
| ⑤ |  | Allen Key 4 (30 x 80mm) | 2 |

Assembly Preparation

Before Beginning Assembly:

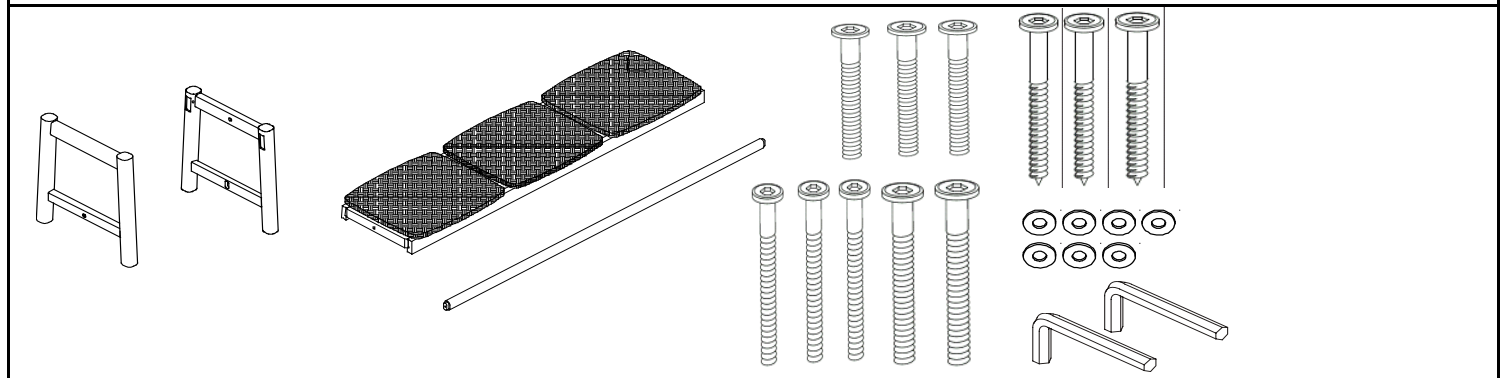



- Read instructions, cover to cover-



- Have 2 adults on hand for assembly-



- Do not assemble on flooring or carpet-



- Assemble on a clean non-marring surface (packing foam)-



- Save all packaging until finished-

Assembly Steps

OVERVIEW

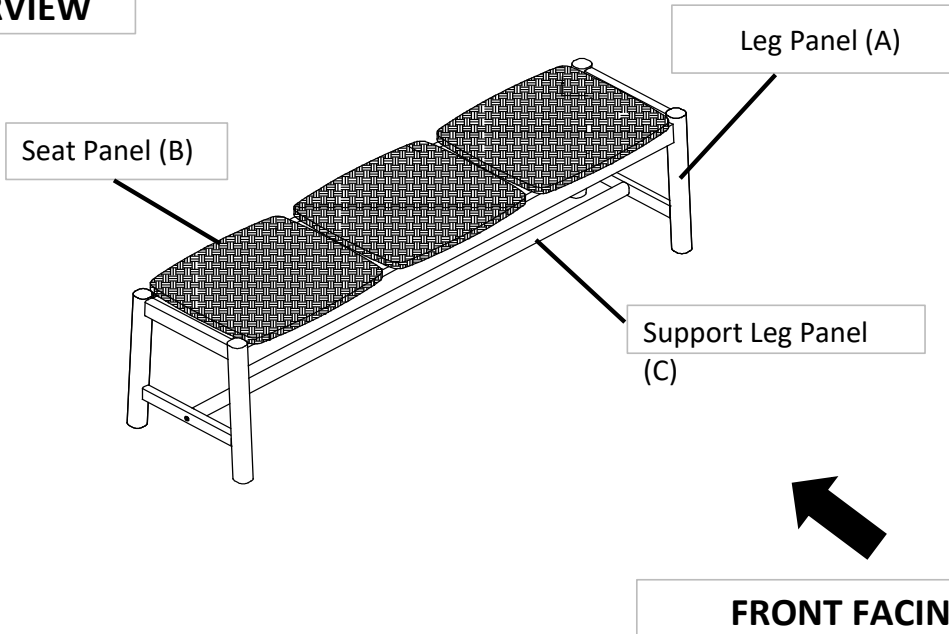

This Bench has multiple parts and may require up to some 30 minutes to assemble. To give you an overview of the Bench, the above picture is to help you put the various parts into perspective. Please read through the instructions here below to familiarise yourself with the parts and steps before assembly.

Step 1

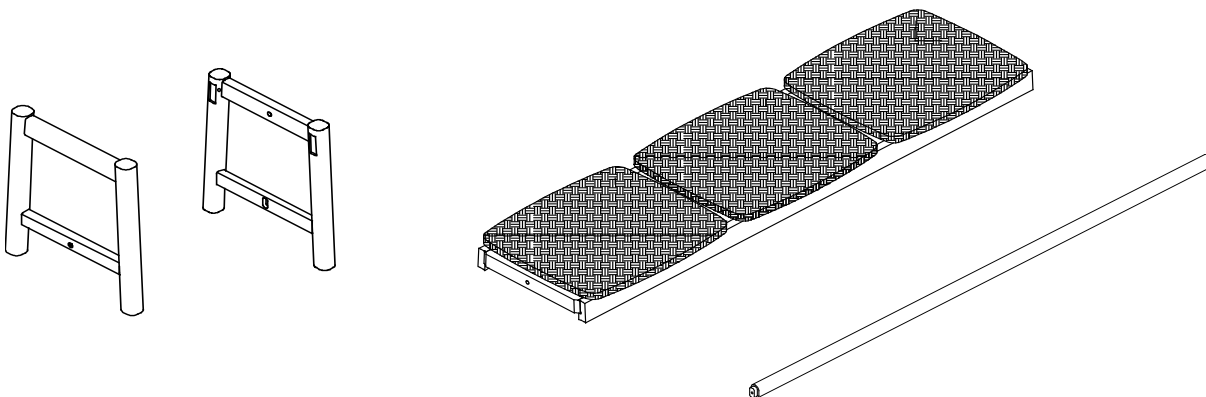

Unpack and place all parts on a clean, non-marring surface.

Step 2

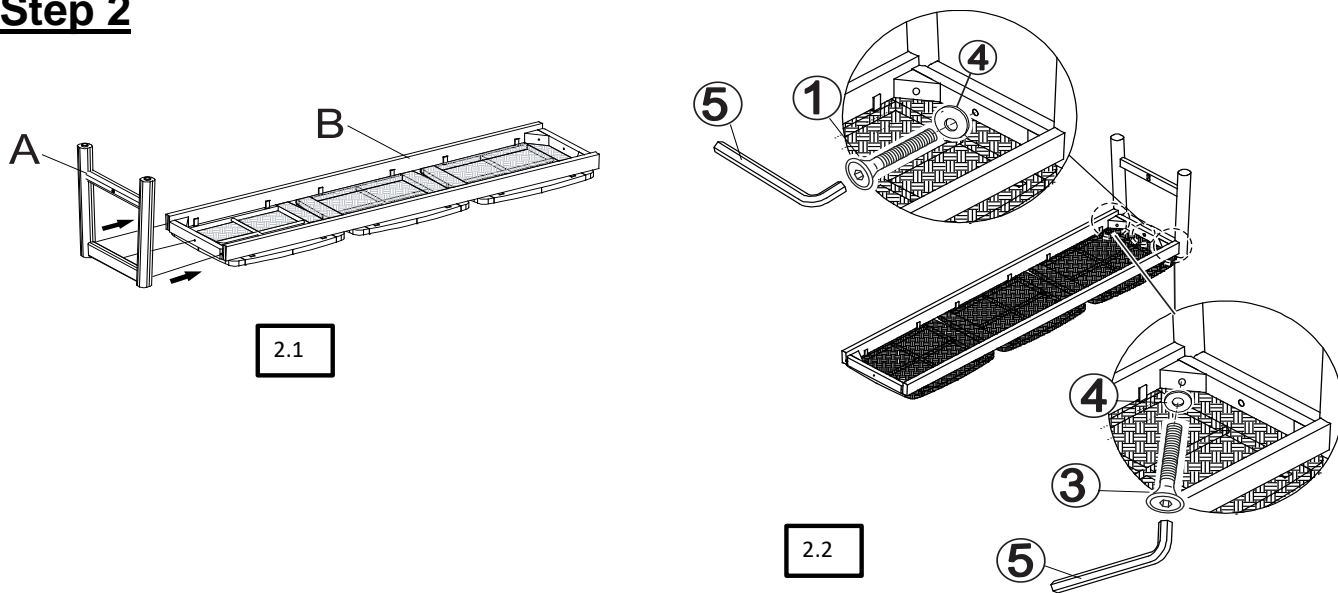

Place the Seat Panel (B) with the inside facing upwards onto a clean, soft surface to avoid any scratches or damage to the product.

2.1: Align the Leg Panel (A) into the positions in the Seat Panel (B), as shown above.

2.2: Secure the Leg Panel (A) to the Seat Panel (B) with Bolts (③), Washers (④) and the Allen Key (⑤), then with Bolts (①) and Washers (④), also using the Allen Key (⑤).

Do not fully tighten the Bolts

Step 3

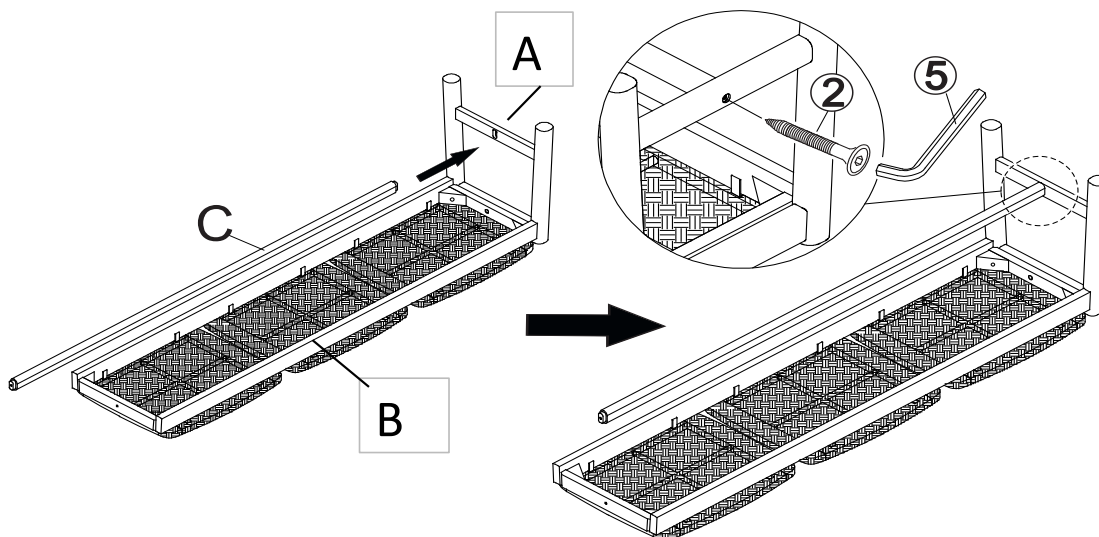

Affix the Support Bar (C) to the Leg Panels (A) using Screws (②) and the Allen Key (⑤).

You may need to push the Leg Panels (A) slightly outwards to affix the Support Bar (C)

Only loosely tighten the Screws.

Step 4

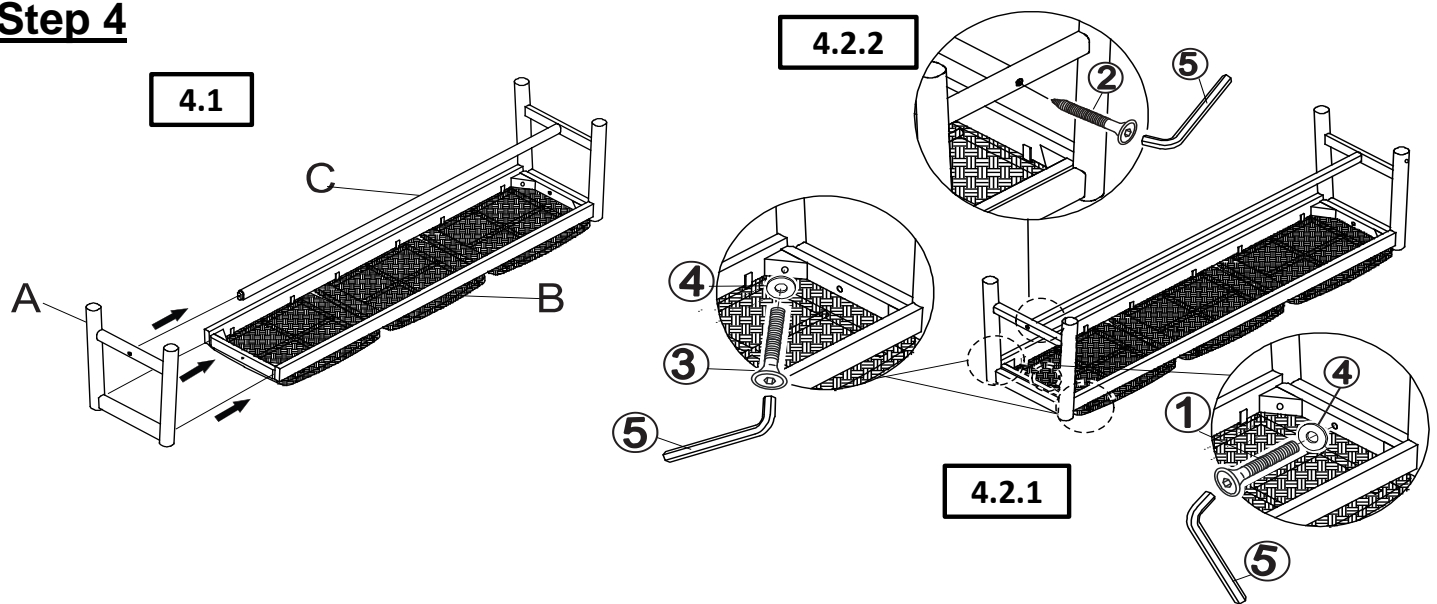

Repeat the same process to attach the remaining Leg Panel (A) to the Seat Panel (B) and Support Bar (C)

4.1: Align the Leg Panel (A) into the positions in the Seat Panel (B) and Support Bar (C), as shown above.

4.2.1: Secure the Leg Panel (A) to the Seat Panel (B) with Washers (④), Bolts (③), and the Allen Key (⑤), then with Washers (④) and Bolts (①), also using the Allen Key (⑤) to secure them in.

4.2.2: Affix the Support Bar (C) to the Leg Panels (A) using Screws (②) and Allen Key (⑤).

Do not fully tighten the Bolts and Screws

Step 5

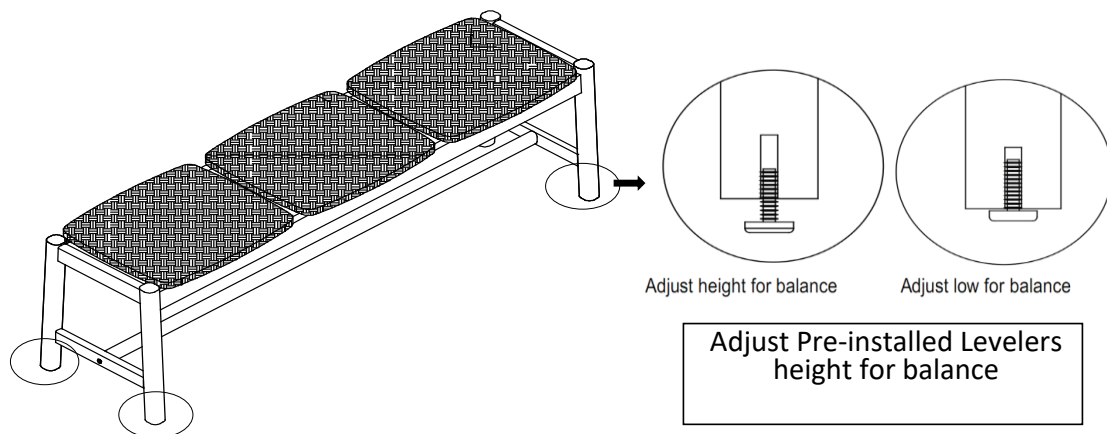

Turn the Bench right side up.

Inspect the Bench and make sure all parts are adequately connected.

In a sequential manner, tighten all Screws and Bolts at all joints.

With assistance from your adult partner, adjust the Levelers to the desired height to avoid wobbling.







The Bench is ready to be used.

CAUTION : When tightening these screws and bolts, tighten sequentially.

DO NOT tighten any screw or bolt fully and then move towards the next one. This could cause the frame to warp.

WARNING!! IF THE BENCH IS NOT STABLE , IT COULD LEAD TO DAMAGING THE PRODUCT.

Care & Maintenance

-  Do not put hot items directly on furniture surface
 -  Do not clean furniture with harsh cleansers or polish.
 -  To obtain the longest lifespan of your outdoor products, minimizing exposure to direct sunlight is recommended.
 -  Children should not climb or jump on the furniture.
 -  Do not write on furniture without a padded barrier to protect the surface.
 -  To obtain the longest lifespan of your outdoor products, avoid extended and lengthy exposure to rain, snow, and direct sunshine. Whenever possible cover the product and /or place under patio or awnings.
 -  Not for commercial use. For residential use only .
 -  Stains may be removed with mild soap solution and damp cloth.
 -  Keep away from sources of ignition.
-
-  Dust and pick-up spills using a clean, non-colored, lint-free cloth.