

Assembly Instruction

Writing Desk with Drawer

DIMENSION : 39.2"(W) x 29"(H) x 17.5"(D)

00:50

Approx. 50 minutes



Recomm. 2 Person

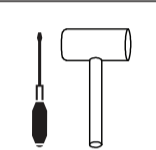

Tool Required

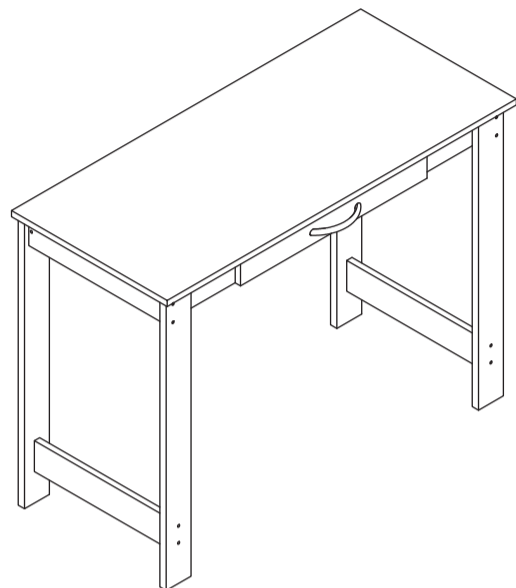

NO	PARTS LIST	QTY
A	TOP PANEL	1pc
B	SIDE SUPPORT PANEL	2pcs
C	FRONT LEFT SUPPORT PANEL	1pc
D	FRONT RIGHT SUPPORT PANEL	1pc
E	BACK SUPPORT PANEL	1pc
F	CENTER LEFT SIDE SUPPORT PANEL	1pc
G	CENTER RIGHT SIDE SUPPORT PANEL	1pc
H	LEG SUPPORT PANEL	2pcs

NO	HARDWARE LIST	QTY
1	MINI FIX BOLT + CAM	2pcs
2	C/B SCREW A	16pcs
3	C/B SCREW B	8pcs
4	C/B SCREW C	4pcs
5	DRAWER SLIDE	1set
6	C/B SCREW D	10pcs
7	HANDLE	1pc
8	BRACKET 45mm	9pcs
9	C/B SCREW E	28pcs

NO	PARTS LIST	QTY
I	LEFT LEG PANEL	2pcs
J	RIGHT LEG PANEL	2pcs
K	DRAWER FACE PANEL	1pc
L	DRAWER LEFT SIDE PANEL	1pc
M	DRAWER RIGHT SIDE PANEL	1pc
N	DRAWER BACK PANEL	1pc
O	DRAWER BASE PANEL	1pc

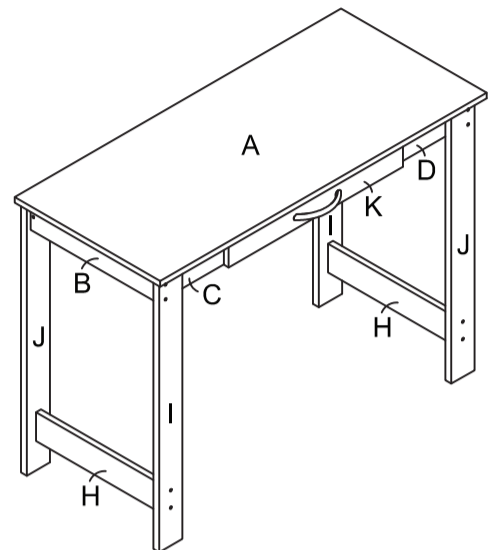

USEFUL HINTS BEFORE YOU START:

1. Read each step carefully before starting.
2. It is important that each step is performed in correct order to avoid difficulties.
3. Identify, sort and count the parts before assembly.
4. Assemble your furniture on packaging cardboard to prevent scratch or damage.
5. Clean the product with mild cleanser using soft damp cloth. Do not use harsh or abrasive cleanser.
6. Using incompatible hardware might cause damage to product.

ASSEMBLY INSTRUCTION

STEP 1

- ATTACH BRACKET (8) TO PANEL (B) (C) (D) (E) (F) & (G), AS SHOWN.

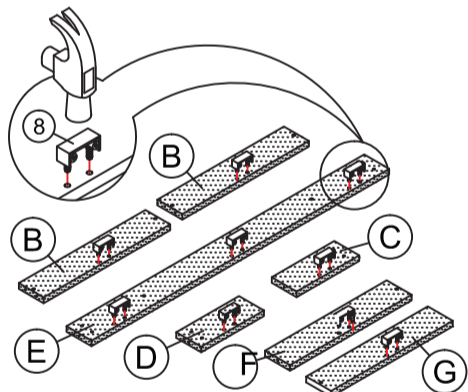

STEP 2

- ATTACH PANEL (F) & (G) TO PANEL (E) USING SCREW (3) AS SHOWN.

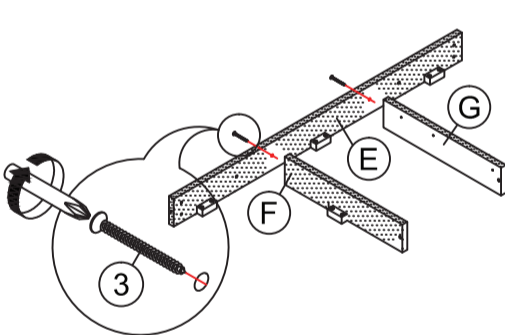

STEP 3

- ATTACH PANEL (B) TO PANEL (E) USING SCREW (3), AS SHOWN.
- ATTACH PANEL (C) & (D) TO PANEL (B) USING SCREW (3), AS SHOWN.
- ATTACH PANEL (F) TO PANEL (C) AND PANEL (G) TO PANEL (D) USING SCREW (3), AS SHOWN.

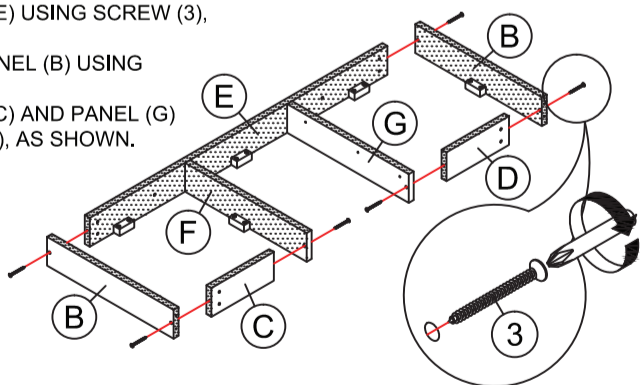

STEP 4

- ATTACH DRAWER SLIDE (5A) TO PANEL (F) & (G) USING SCREW (6), AS SHOWN.

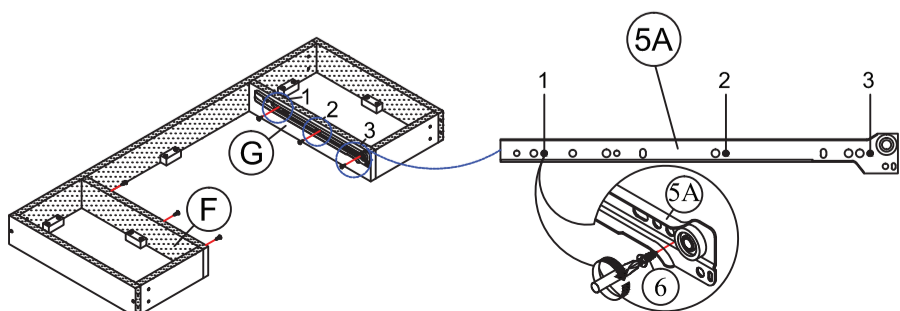

STEP 5

- ATTACH ASSEMBLED UNIT STEP (4) TO PANEL (A) USING BRACKET (8) AND SCREW (9), AS SHOWN.

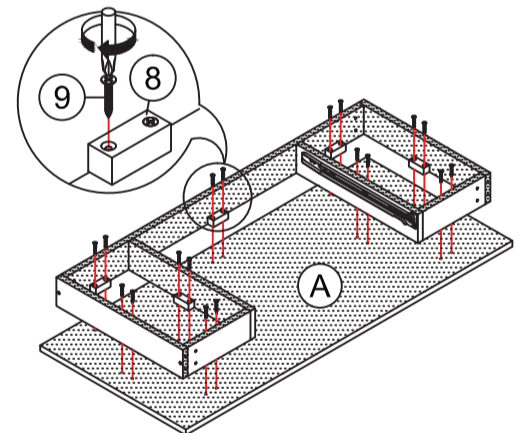

STEP 6

- ATTACH PANEL (I) (H) & (J) TO ASSEMBLED UNIT STEP (5) USING SCREW (2), AS SHOWN.
- ATTACH ASSEMBLED UNIT TO PANEL (I) & (J) USING SCREW (9), AS SHOWN.

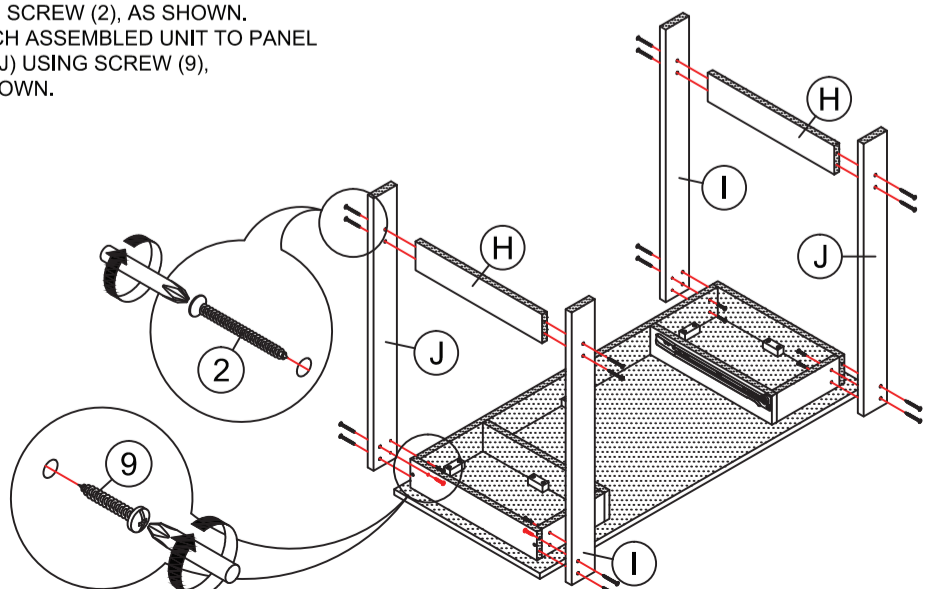

STEP 7
ATTACH MINI FIX BOLT (1A) TO PANEL (K), AS SHOWN.

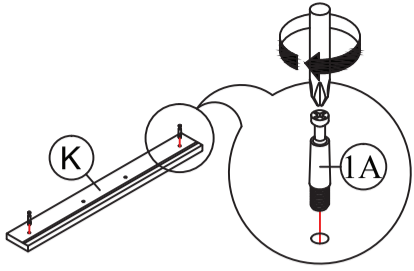

STEP 8
ATTACH MINI FIX CAM (1B) TO PANEL (L) & (M), AS SHOWN.

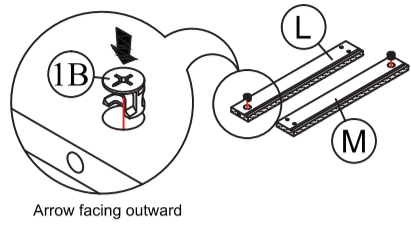

STEP 9
ATTACH PANEL (L) & (M) TO PANEL (K) USING MINI FIX BOLT (1A) & CAM (1B) AND TIGHTEN IT, AS SHOWN.

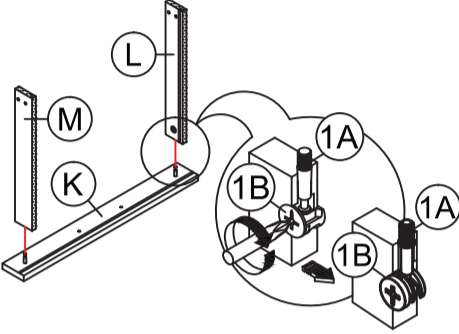

STEP 10
INSERT PANEL (O) TO DITCH OF PANEL (L) & (M), AS SHOWN.

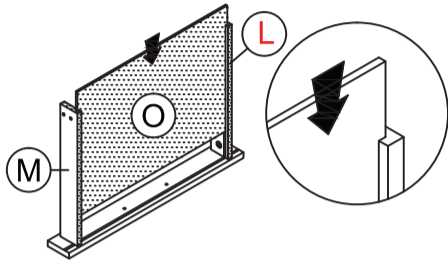

STEP 11
ATTACH PANEL (N) TO ASSEMBLED UNIT STEP (11) USING SCREW (4), AS SHOWN.

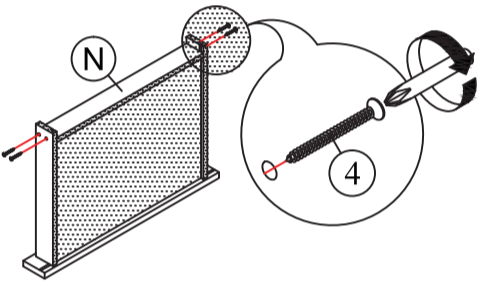

STEP 12
ATTACH HANDLE (7) TO PANEL (K) USING SCREW (9), AS SHOWN.

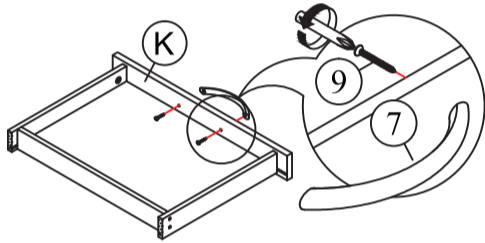

STEP 13
ATTACH DRAWER SLIDE (5B) TO ASSEMBLED UNIT STEP (13) USING SCREW (6), AS SHOWN.

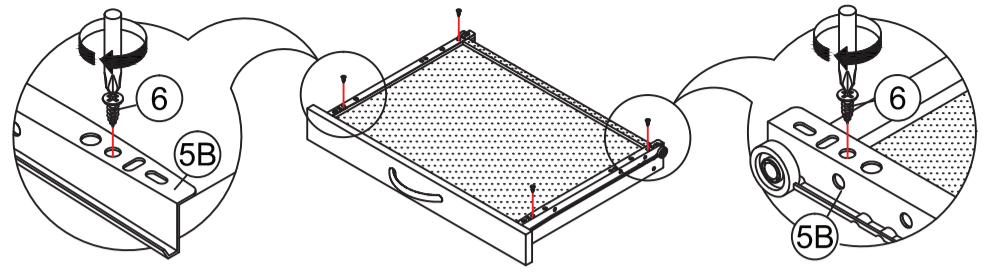

STEP 14
ATTACH ASSEMBLED UNIT STEP (13) TO ASSEMBLED UNIT STEP (6), AS SHOWN.

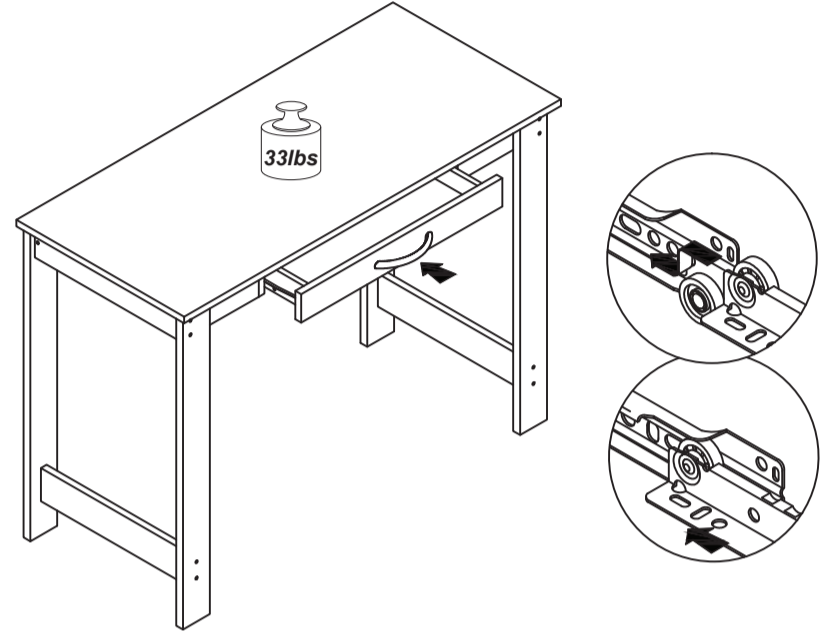

WARNING:

>This unit has been designed to support the maximum loads shown. Exceeding these load limits could cause sagging, instability, product collapse, and/or serious injury.
>DO NOT allow children to climb on unit.