

USER MANUAL



8-DRAWER FILING CABINET

Model: JY-260109

TOOLS REQUIRED

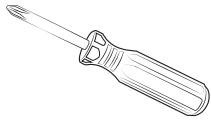

Phillips screwdriver
(Not included)

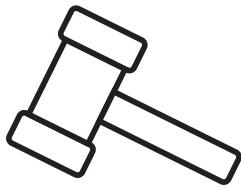

Hammer
(Not included)

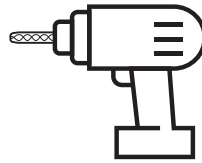

Drill
(Not included)

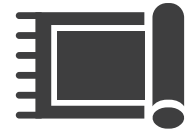

Protective blanket
(Not included)



ATTENTION

Keep children and pets away while assembling.



How to use cam locks

CAM LOCK FASTENING SYSTEM

This Cam Lock Fastening System will be used throughout the assembly process.

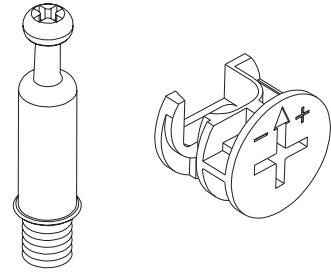

1

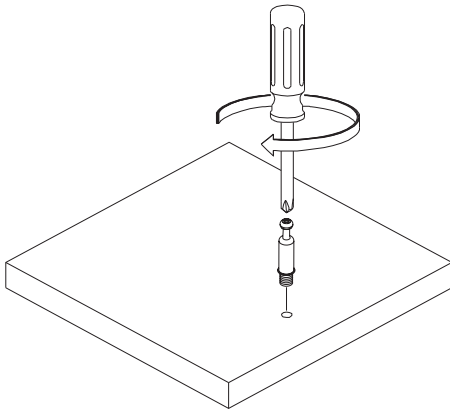

2

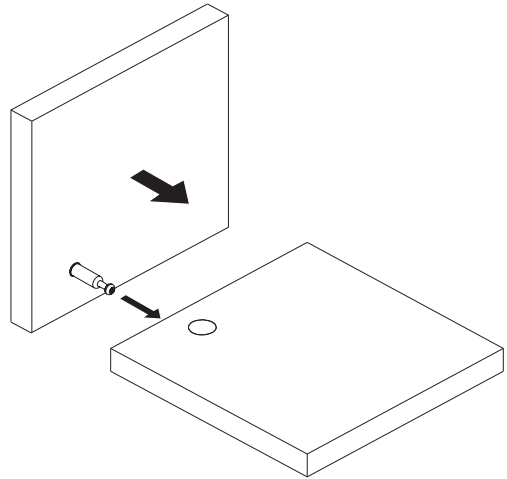

3

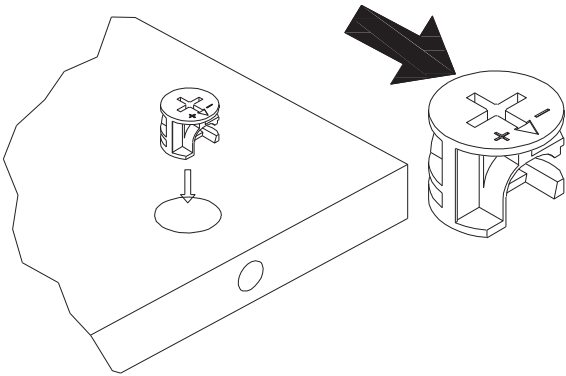

4

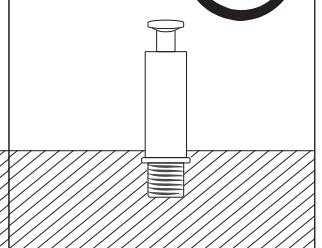
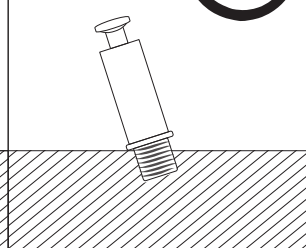
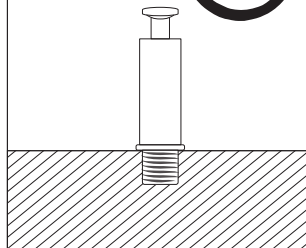
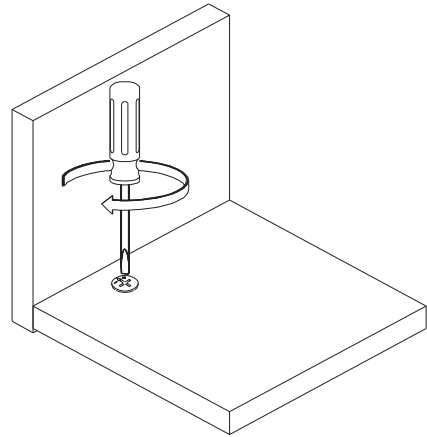

INTRODUCTION

Thank you for choosing our products. Please read the instructions carefully and keep them for future reference. If you need further assistance, please contact our customer service online via email.

PRECAUTIONS

1. When installing the product, use a soft underlay (such as carpet or cardboard) to avoid scratching or damaging the surface of the product.
2. Please try to use a manual screwdriver instead of electric screw driver. A manual screwdriver can be used to better control the tightness of the screws.
3. Do not use any glue.
4. The product is unstable before it is assembled. Please pay attention to the product installation sequence.
5. The structure of this product can not meet the requirements of the placement of heavy items and children climbing.







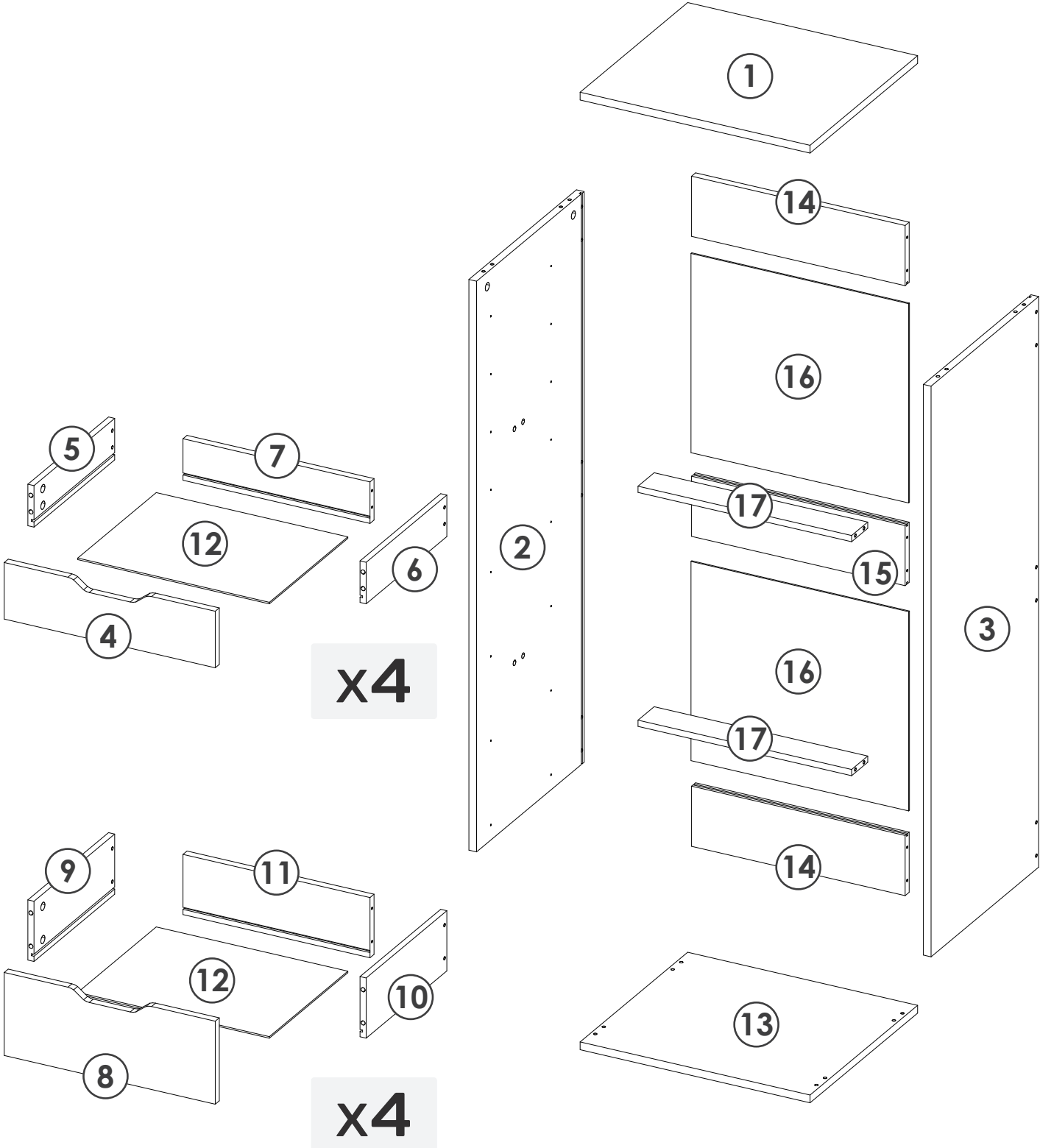

WARRANTY

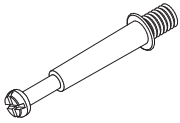
We provides an **18 Month** Warranty on all products starting from the date of original purchase. If the product has any manufacturing defect, please contact customer service via email with your order number and other details to the problem. We will send you further information about the return or exchange.

PACKAGE CONTAINS

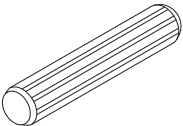
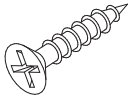
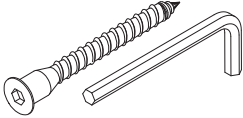

HARDWARES LIST

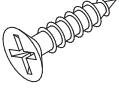
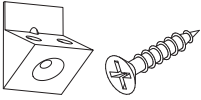
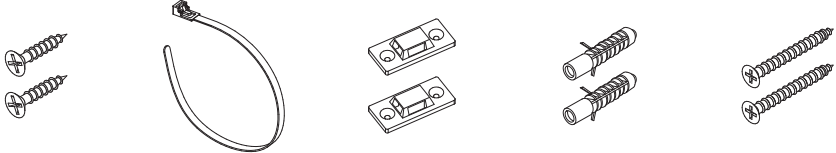
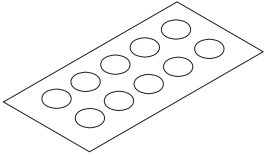
<p>A x44</p>  <p>M6x35mm</p>	<p>B x44</p>  <p>M15*10mm</p>		
<p>C = CL + CR + DL + DR x8</p> <p>CR  CL </p> <p>DR  DL </p> <p>12 INCHES</p>		<p>D x8</p>  <p>M8*40mm</p>	
<p>E x32</p>  <p>M3.5*14mm</p>	<p>F x48/x1</p>  <p>M5*40mm/#3</p>	<p>G x4</p> 	<p>H x32</p>  <p>M3*12mm</p>
<p>J x8</p>  <p>M3*14mm</p>	<p>K x2</p> 		
<p>L x44</p>  <p>21mm</p>			

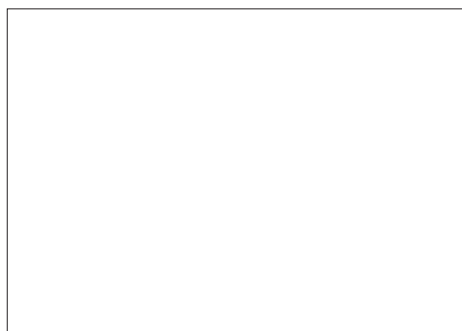
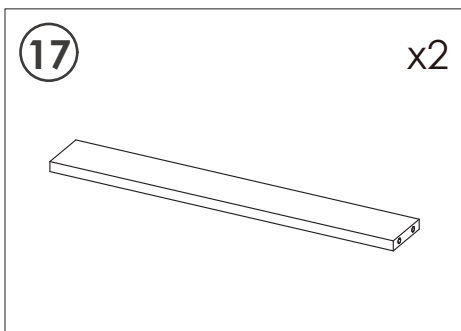
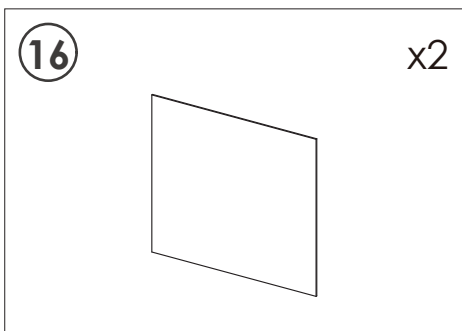
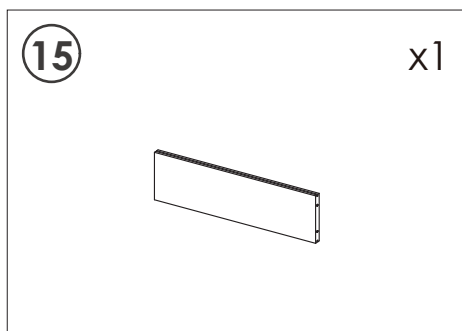
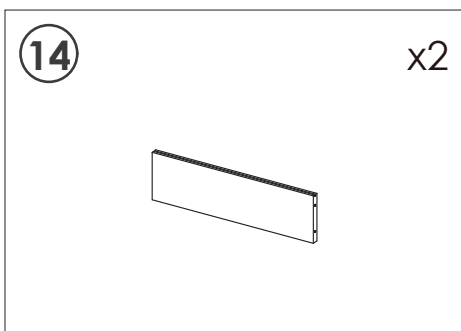
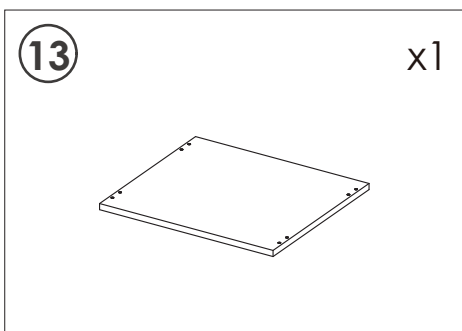
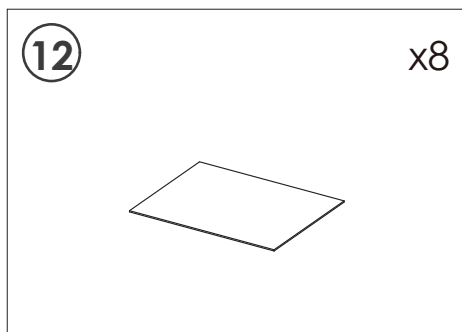
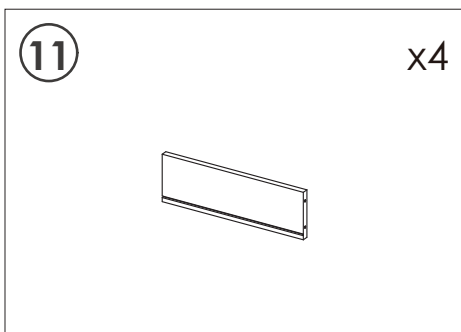
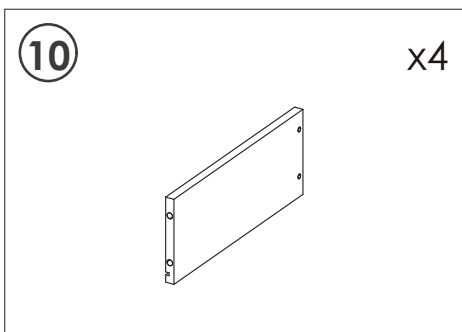
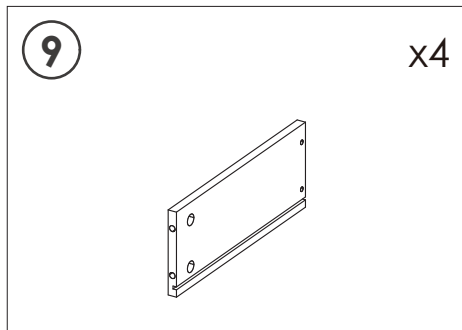
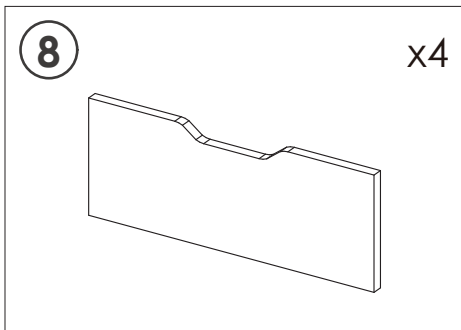
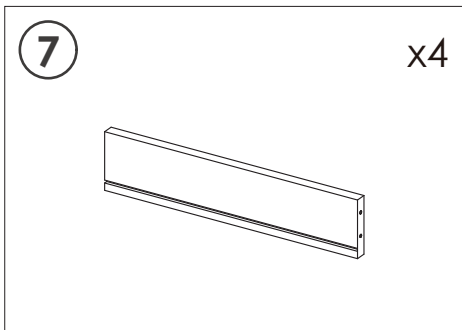
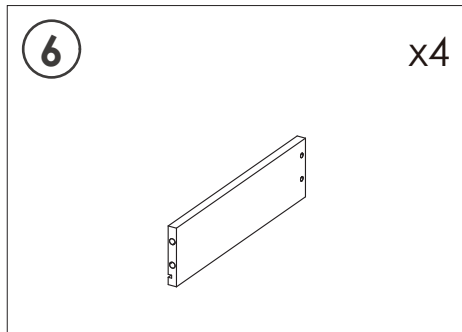
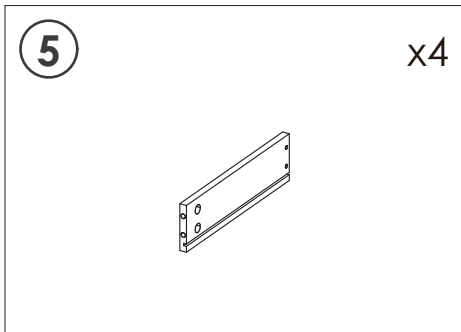
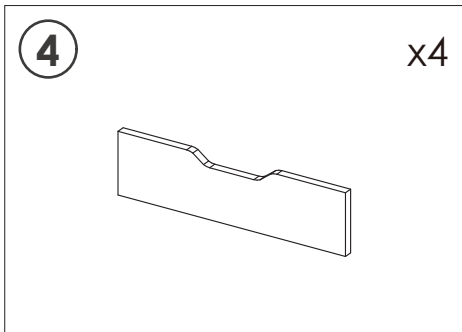
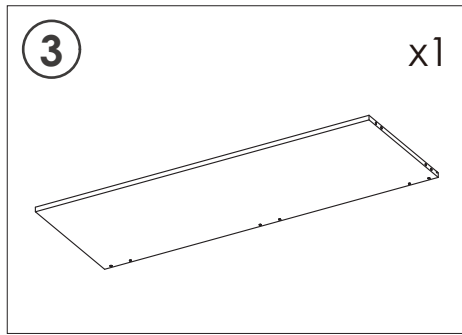
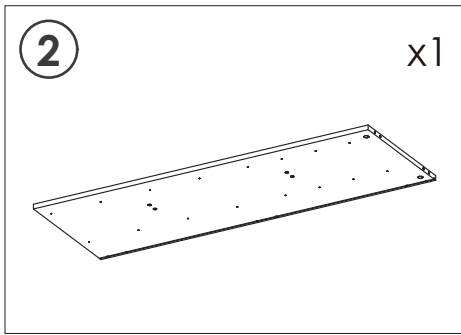
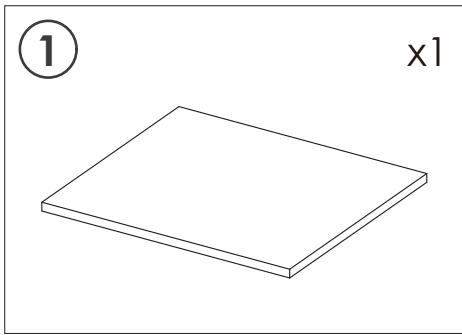

INSTALLATION INSTRUCTION

01

CL x8pcs



E x16pcs



M3.5*14mm

CL

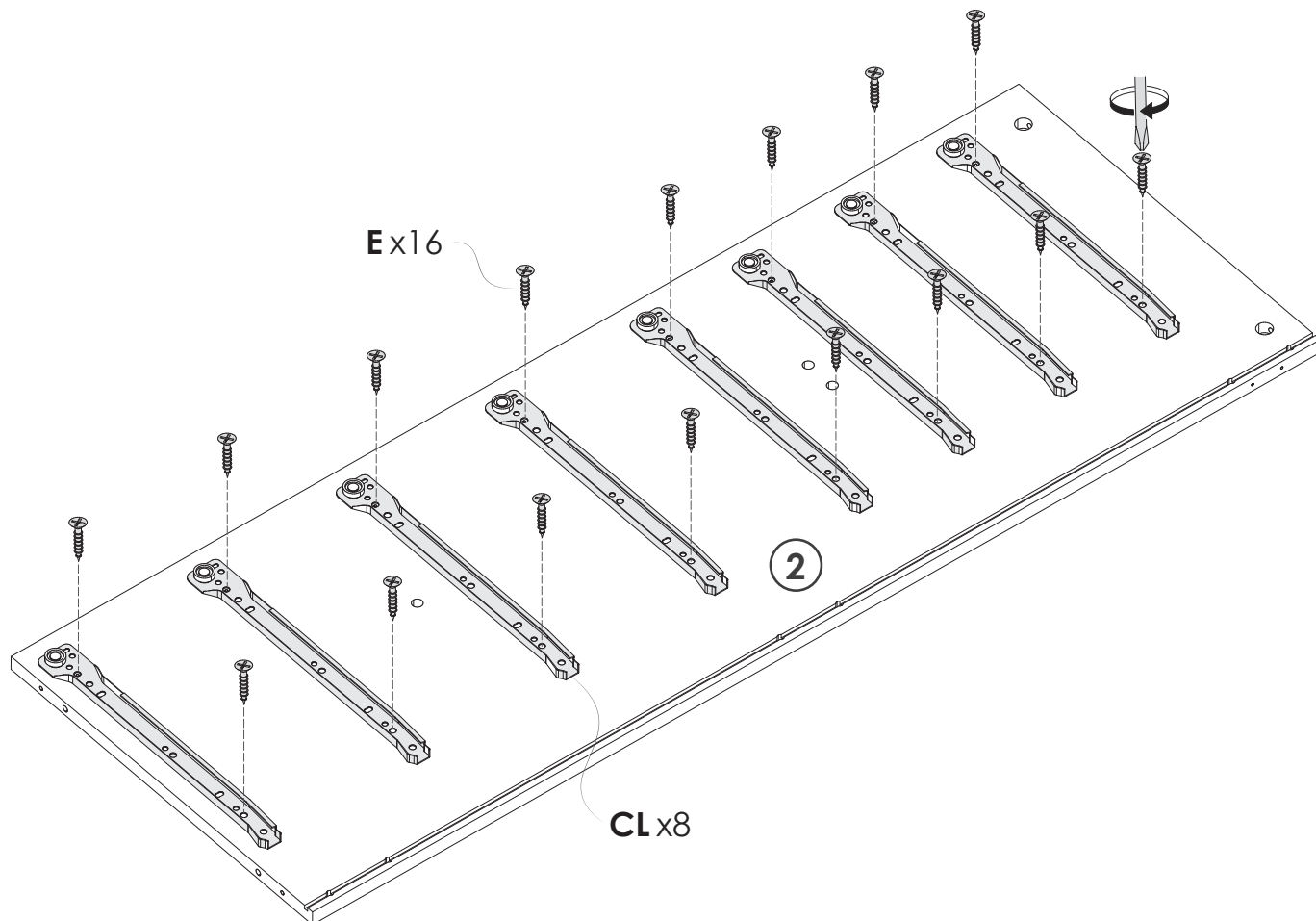
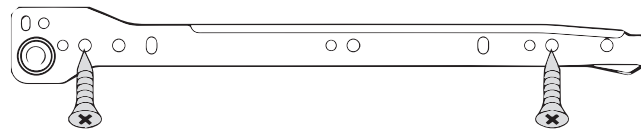

02

CR x8pcs



E x16pcs



M3.5*14mm

CR

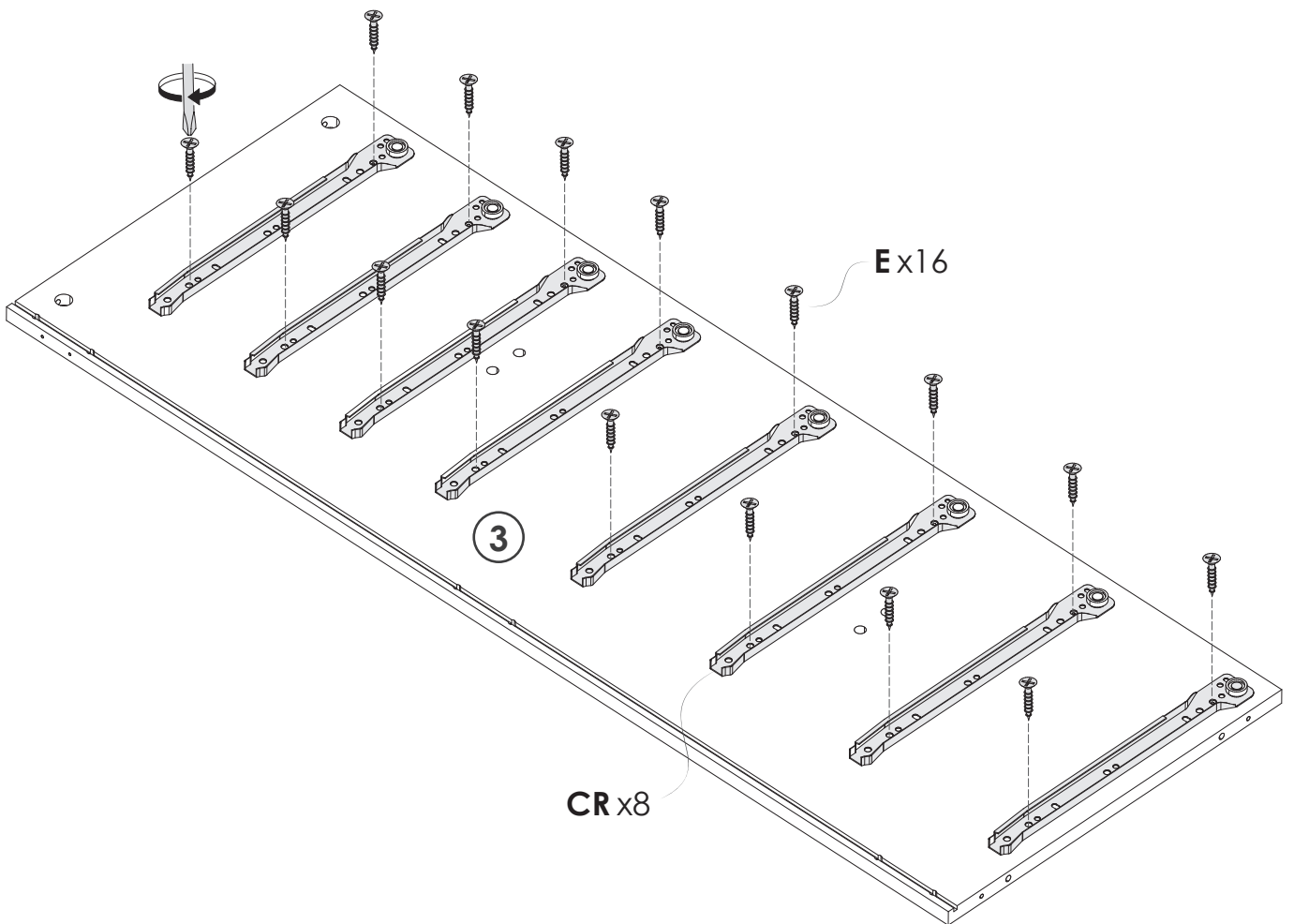
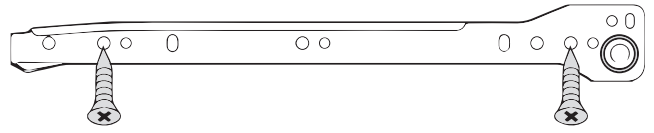

03

A x4pcs



M6*35mm

F x6pcs



M5*40mm/#3

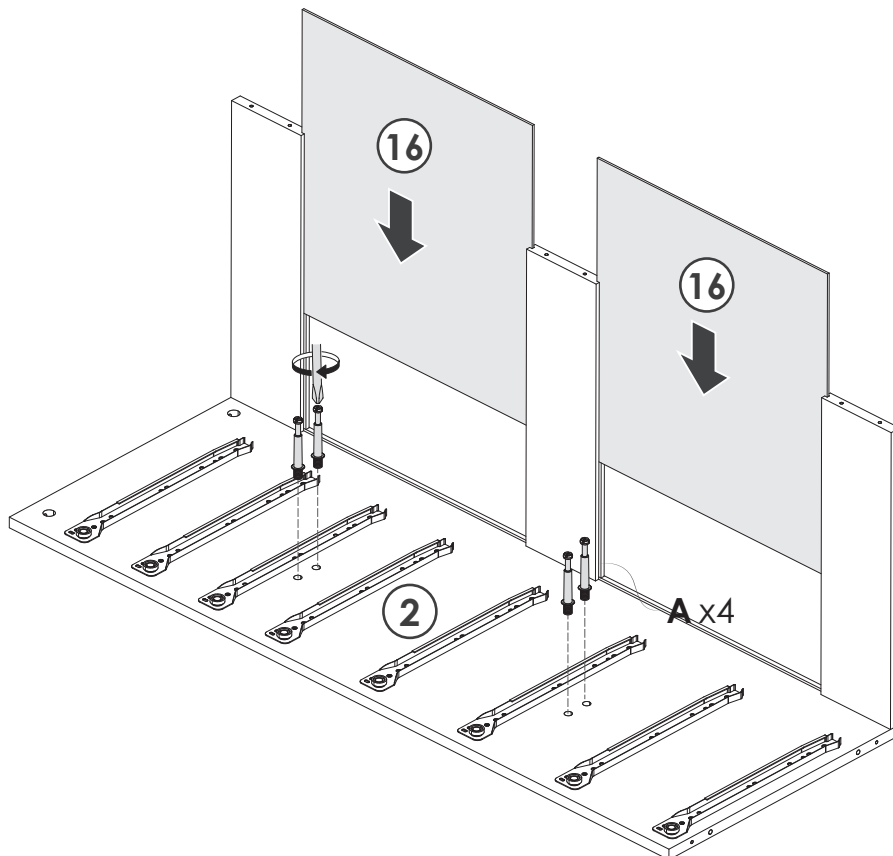
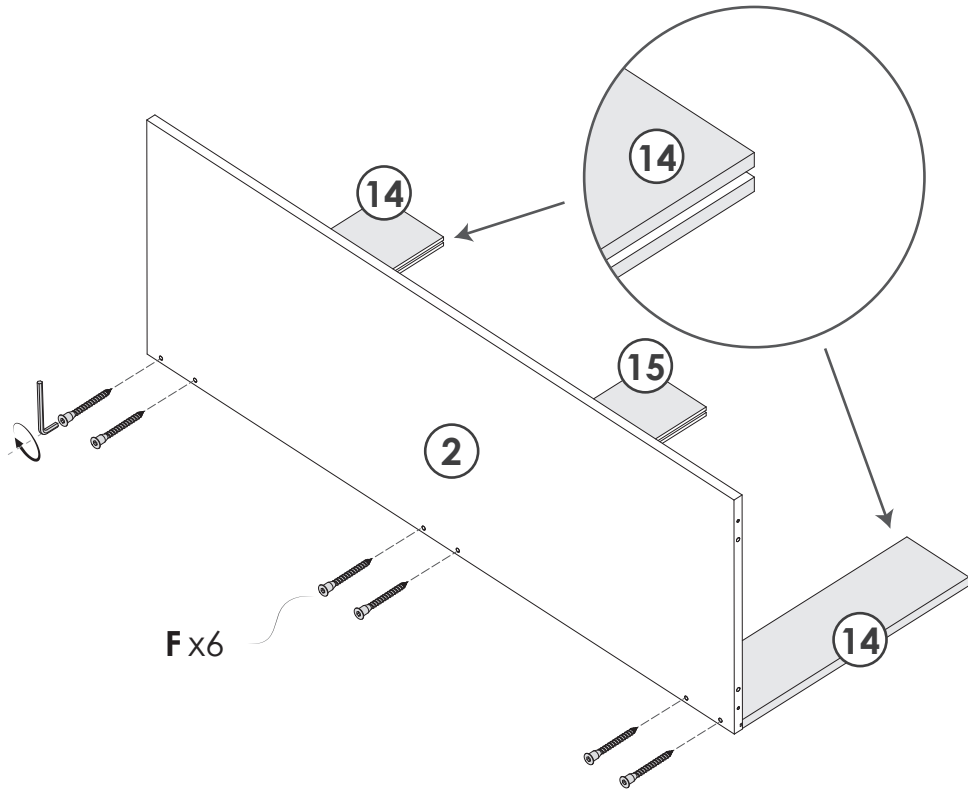

04

B x4pcs



M15*10mm

Installation method of three in one rod and buckle

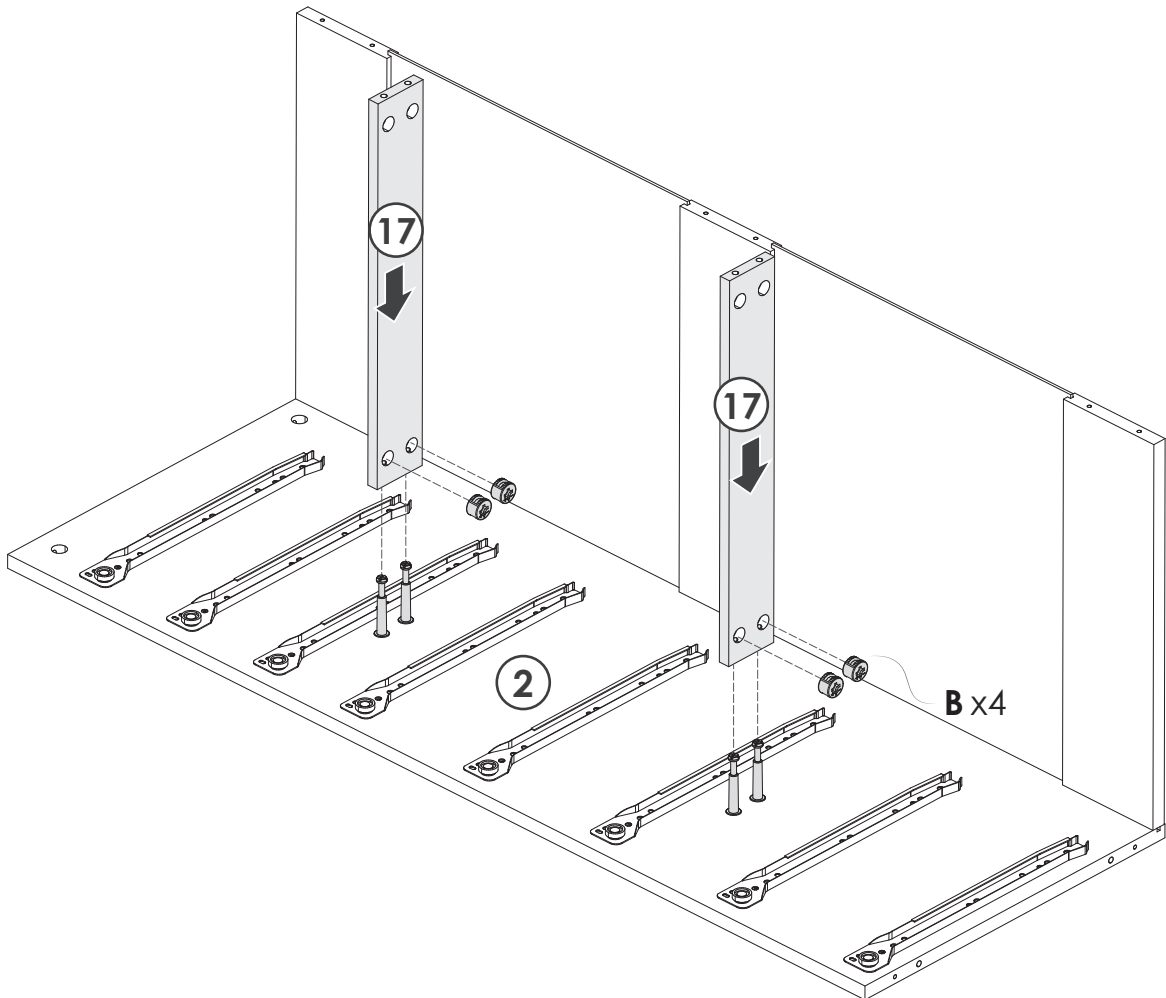
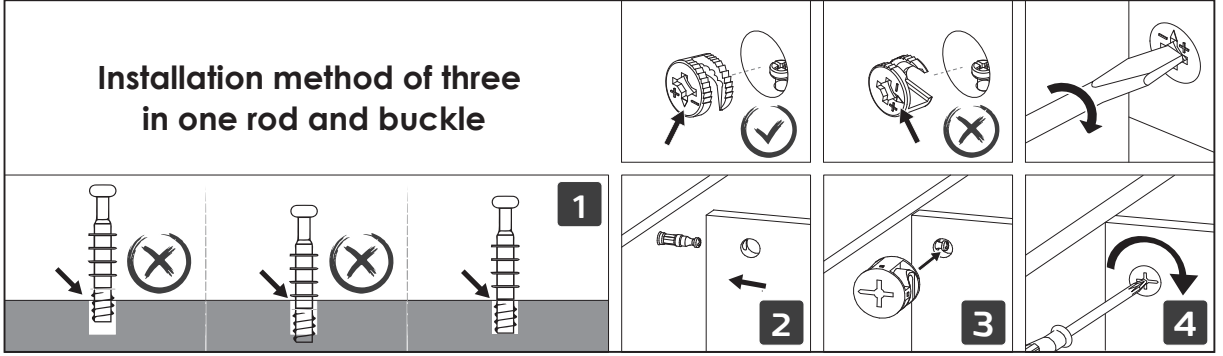

05

A x4pcs



M6*35mm

B x4pcs



M15*10mm

D x4pcs



M8*40mm

F x6pcs



M5*40mm/#3

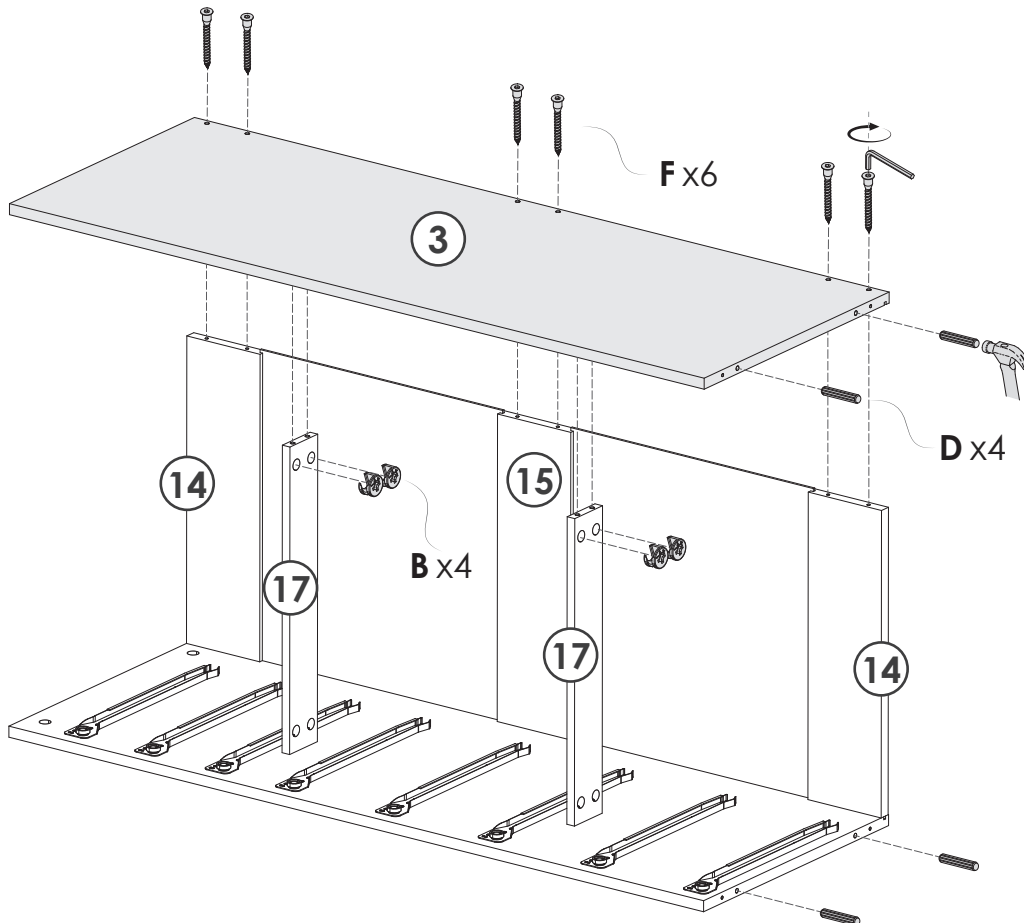
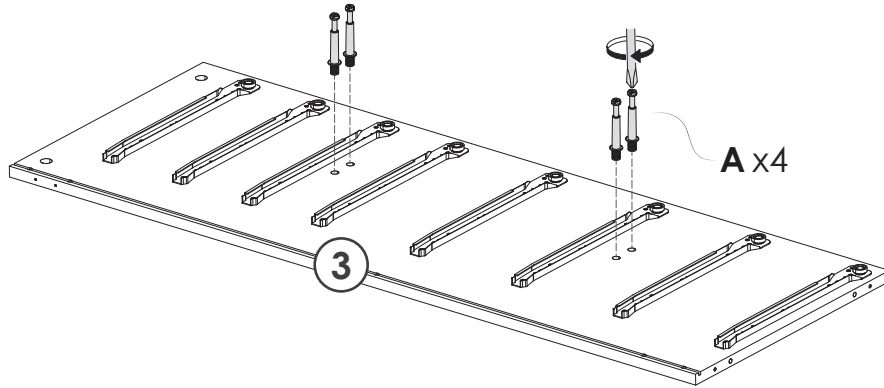
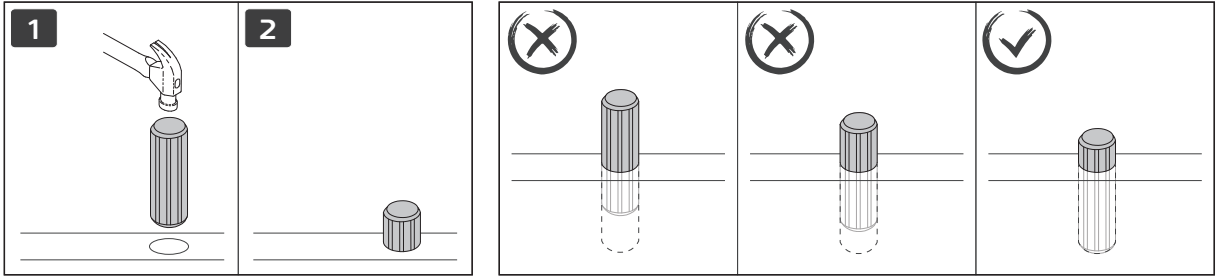

06

F x4pcs



M5*40mm/#3

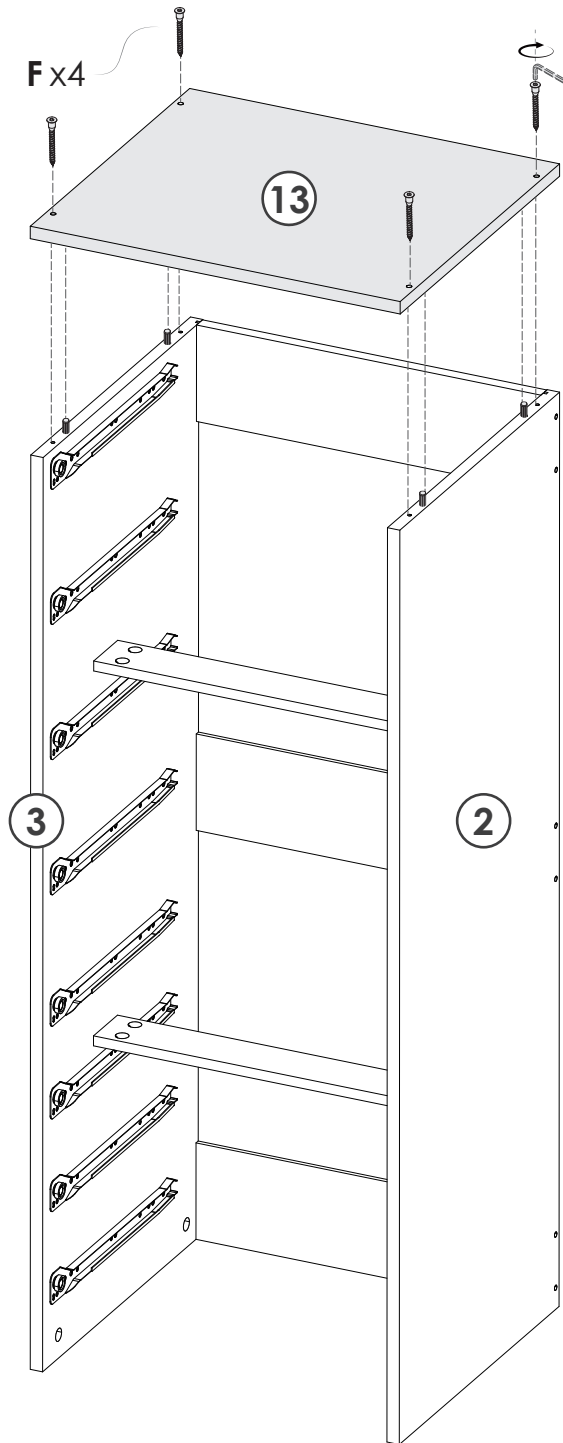

07

G x4pcs

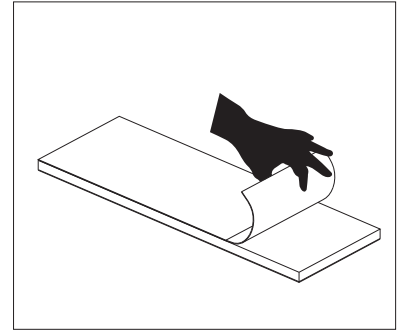
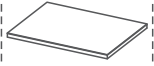

08

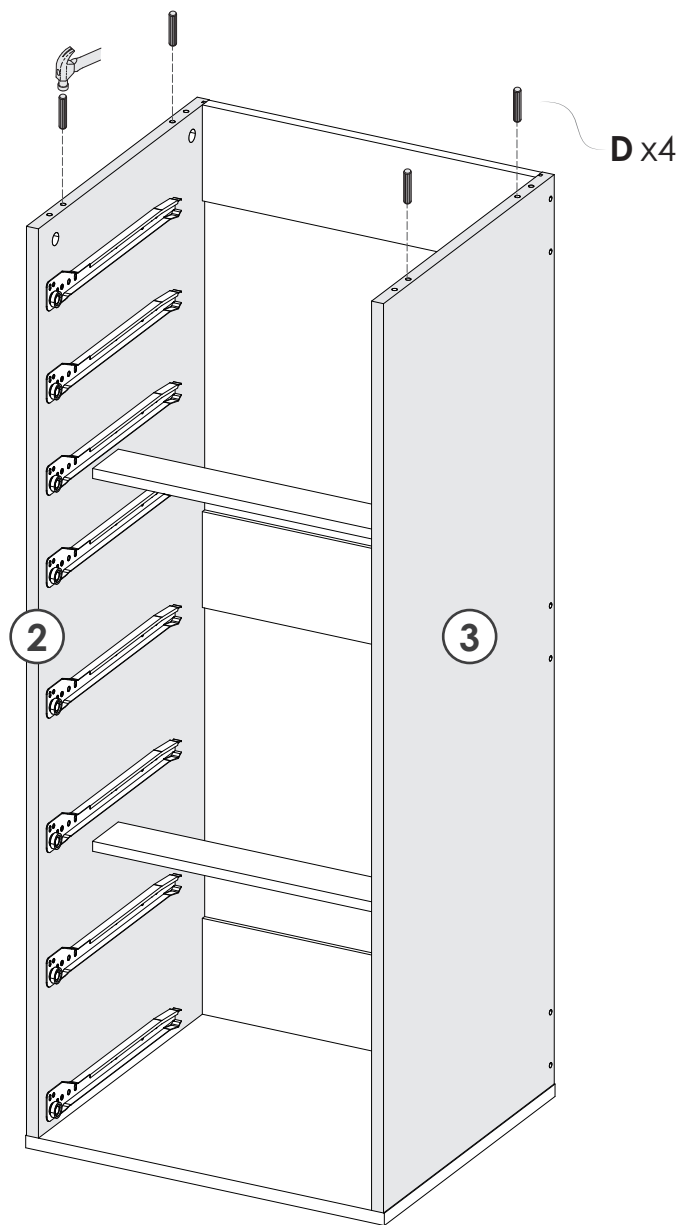
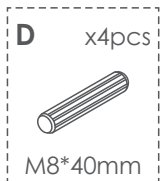

09

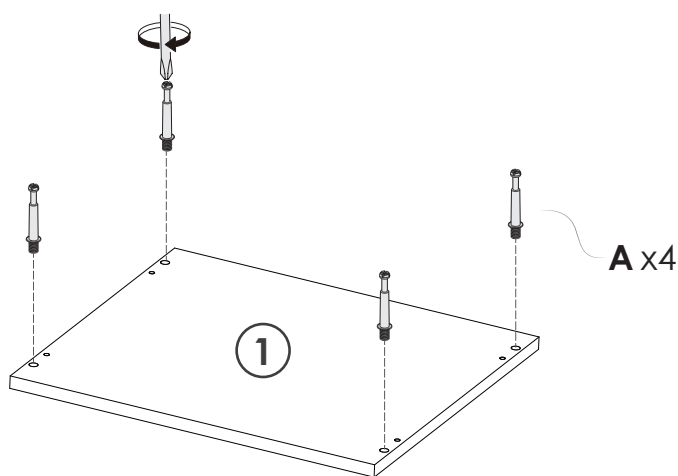
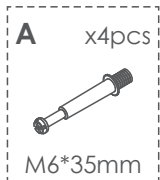

10

B x4pcs



M15*10mm

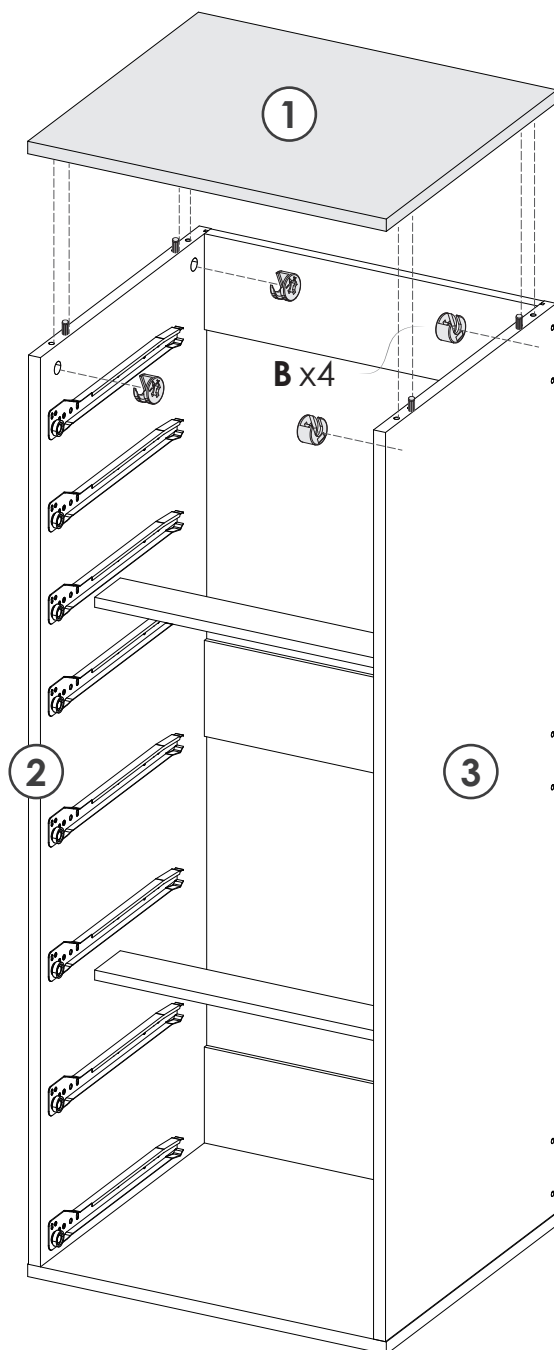

11

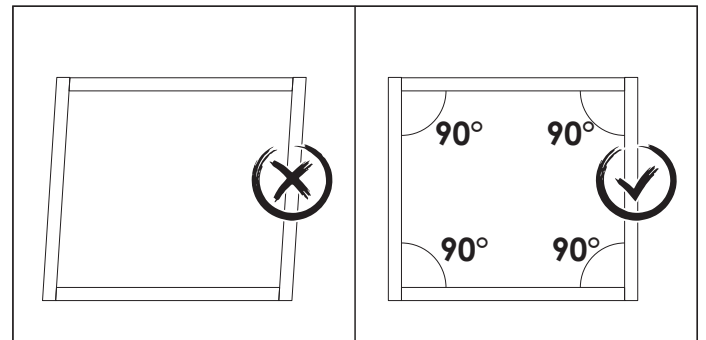
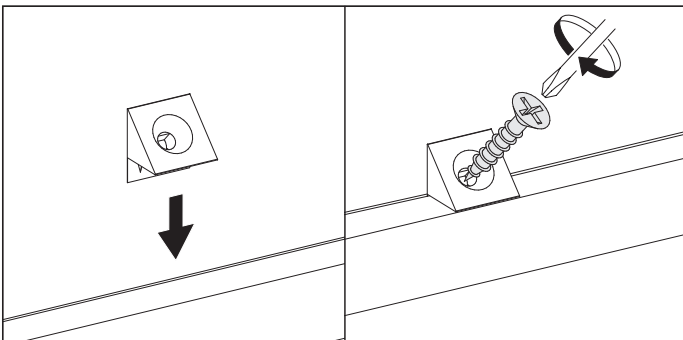
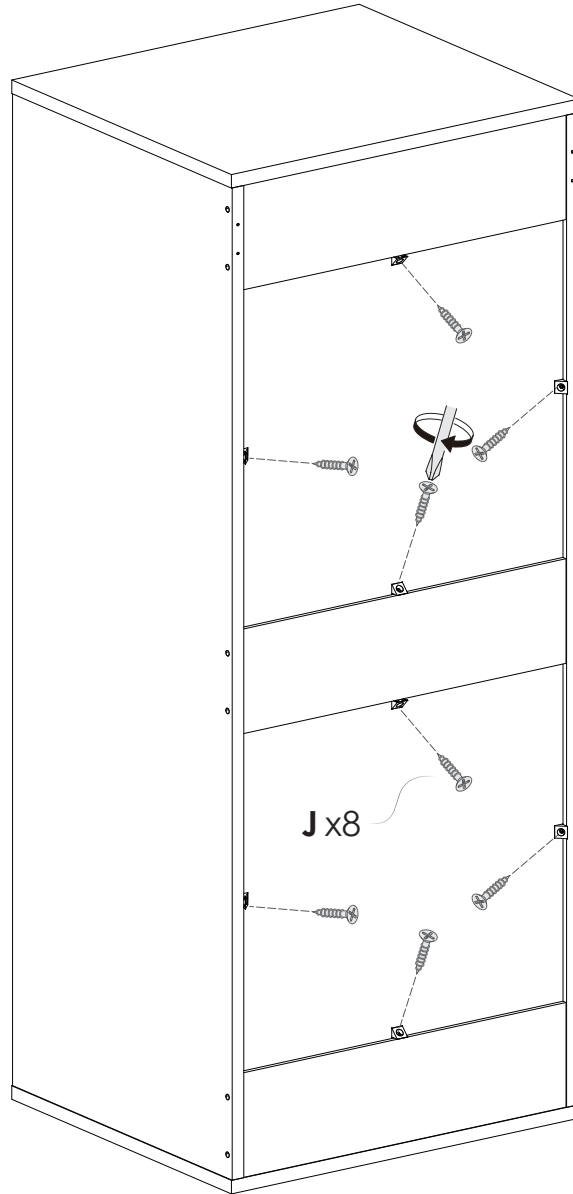
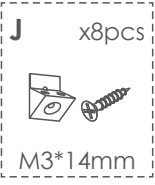

12

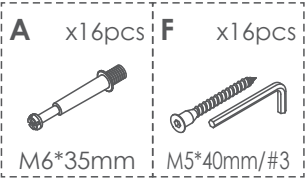

1

2

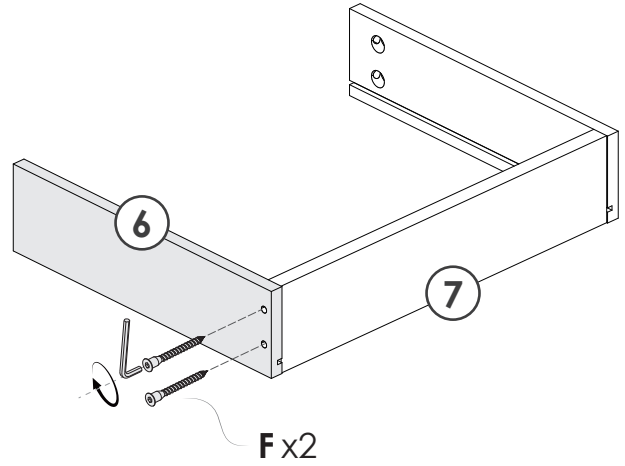
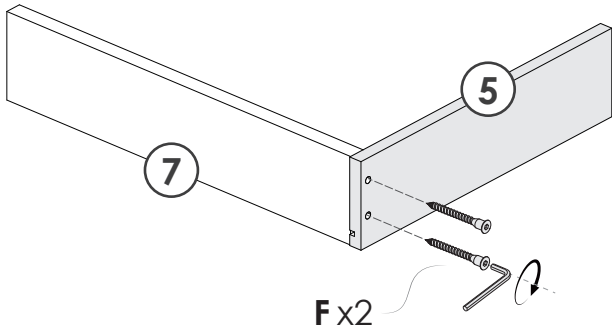

3

x4

4

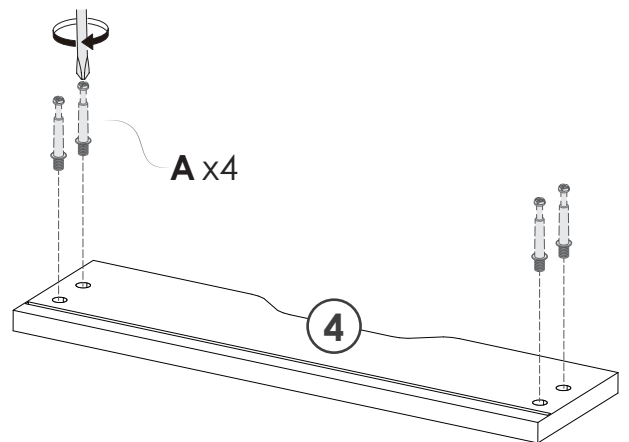
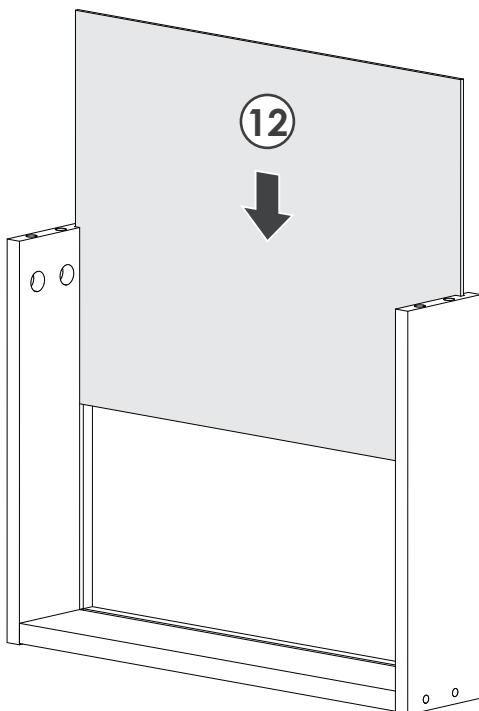

13

B x16pcs



M15*10mm

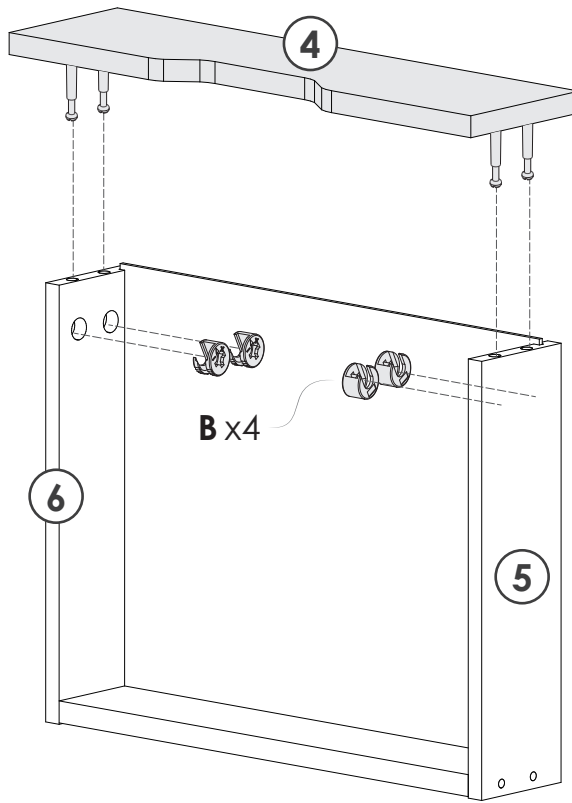

x4

DL

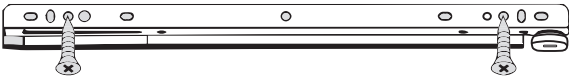

DR

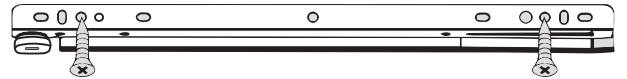

DL x4pcs



DR x4pcs



H x16pcs



M3*12mm

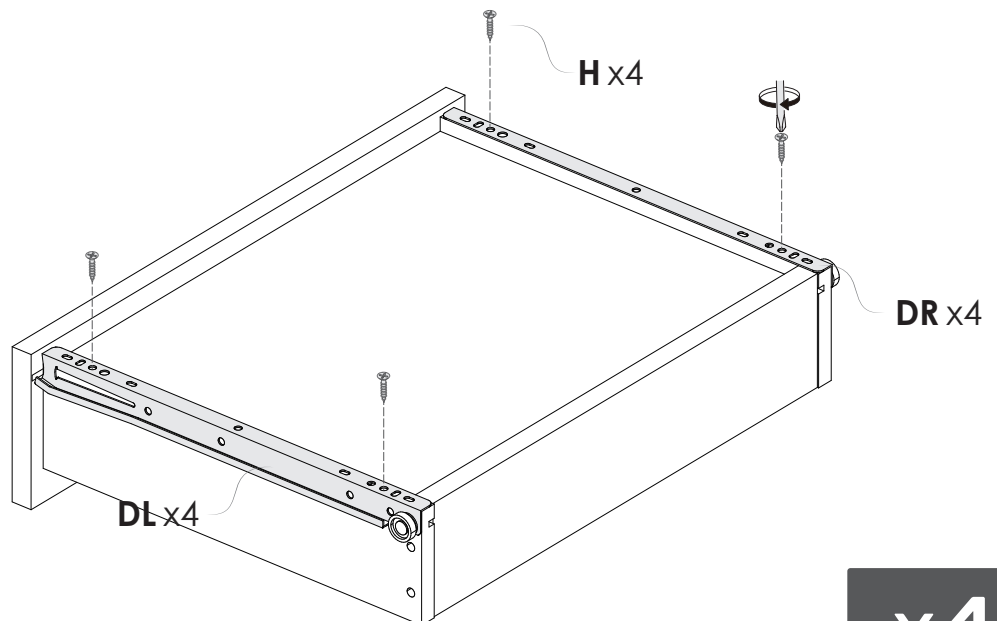

x4

14

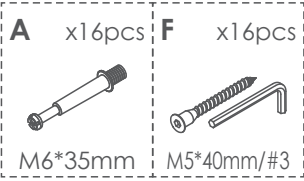

1

2

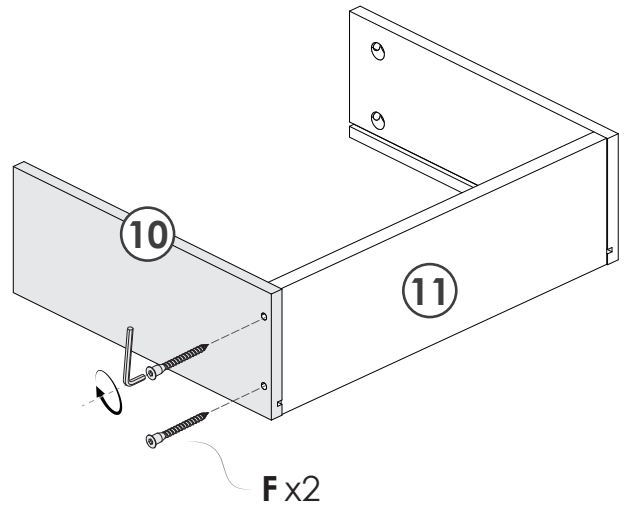
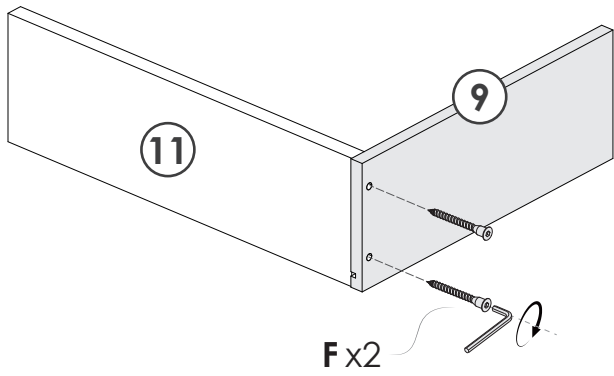

x4

3

4

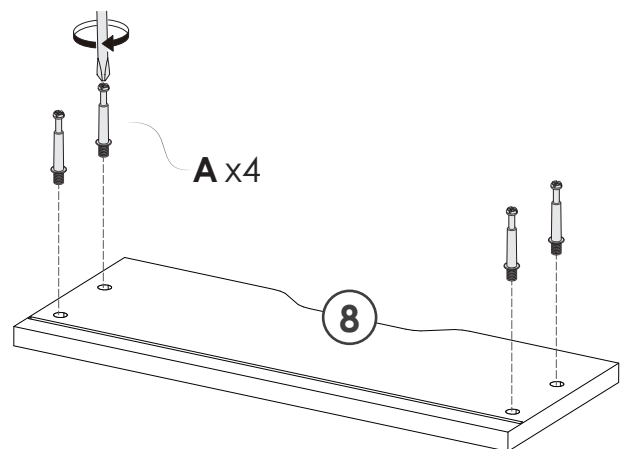
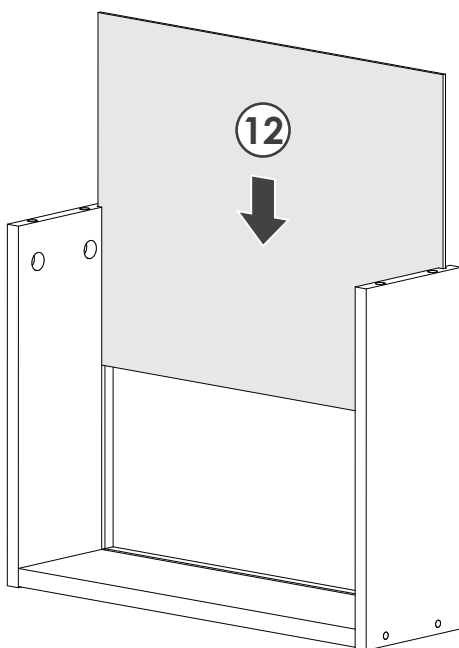

15

B x16pcs



M15*10mm

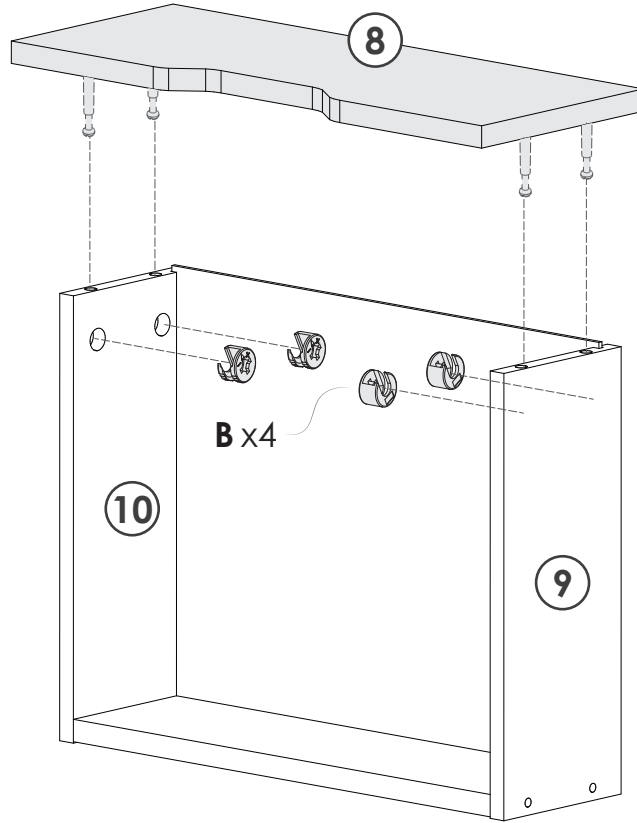

x4

DL

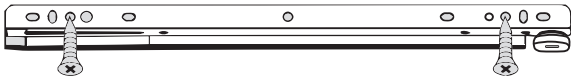

DR

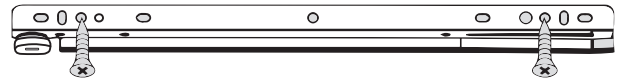

DL x4pcs

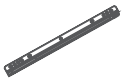

DR x4pcs



H x16pcs



M3*12mm

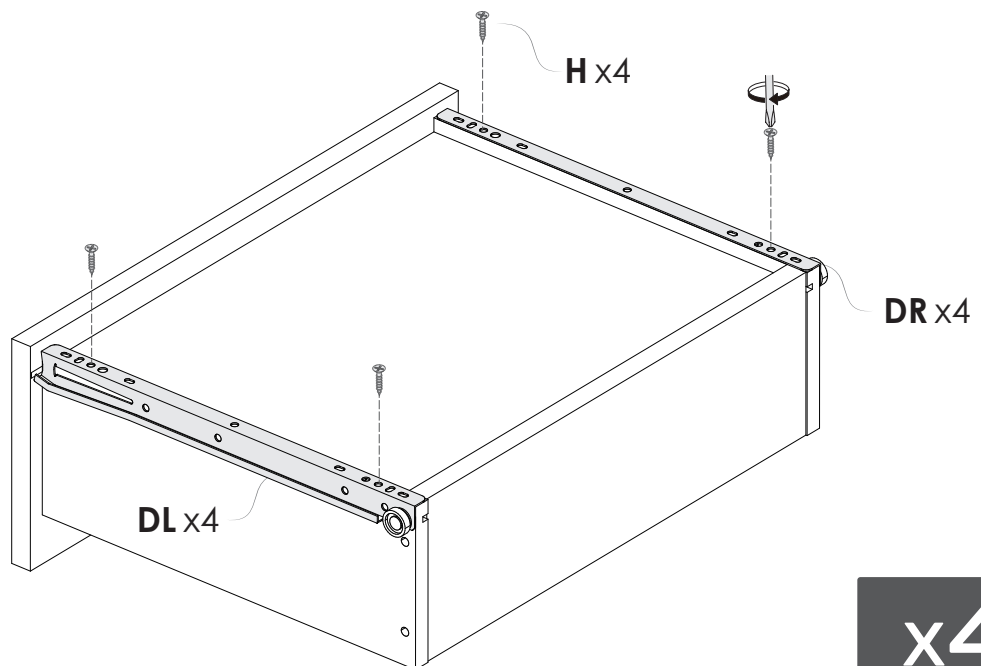

x4

16

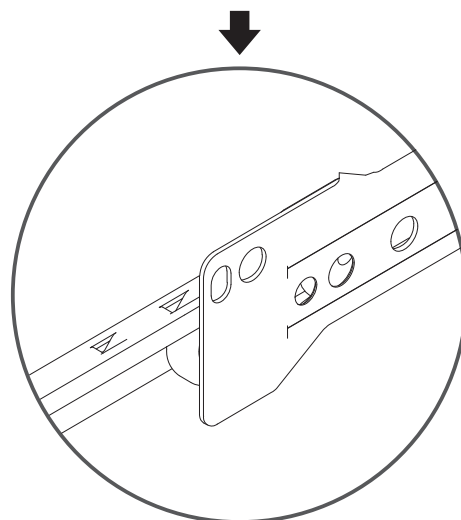
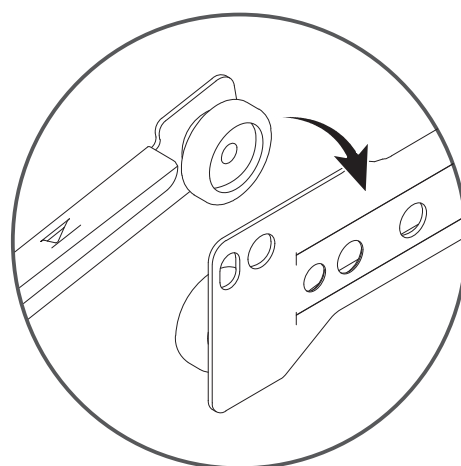
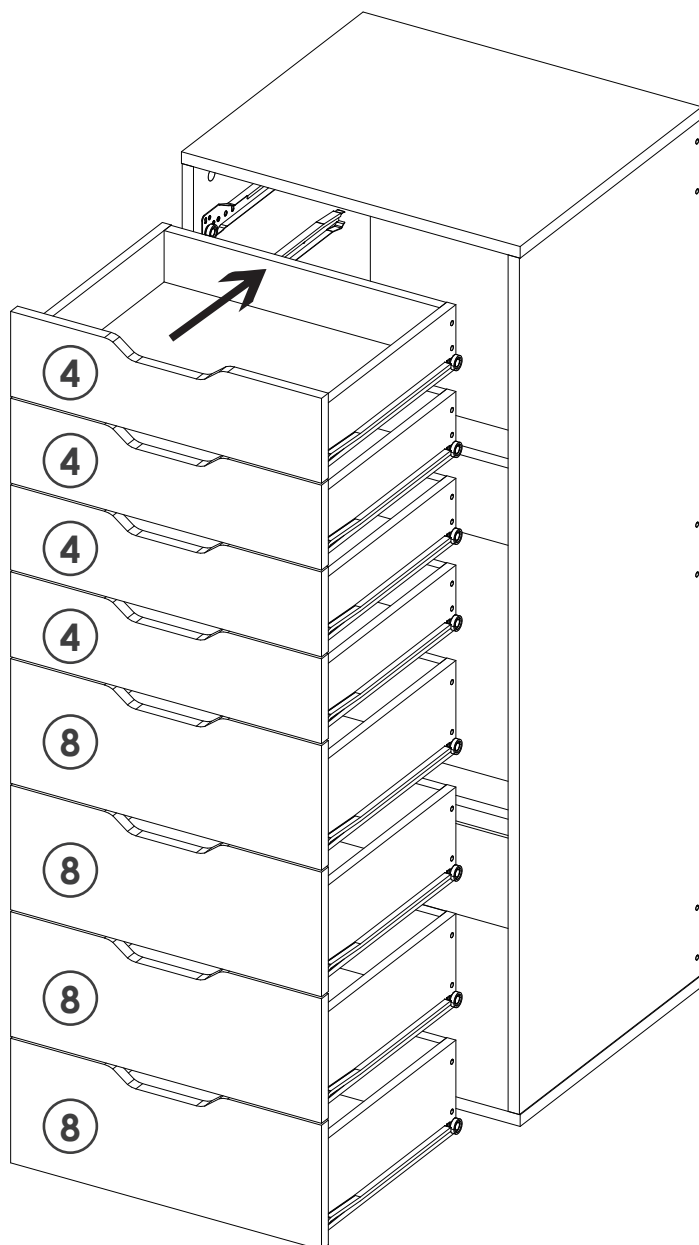
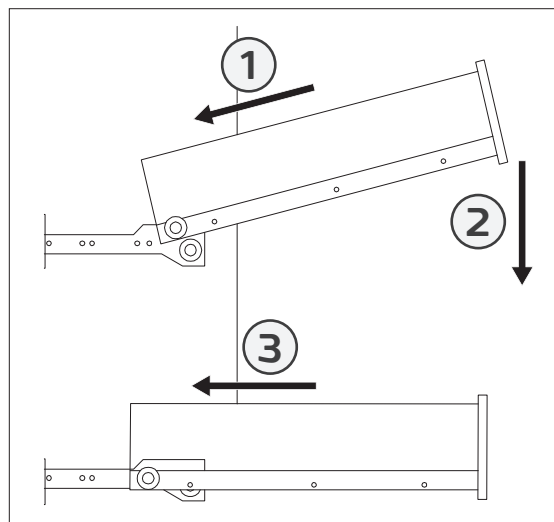
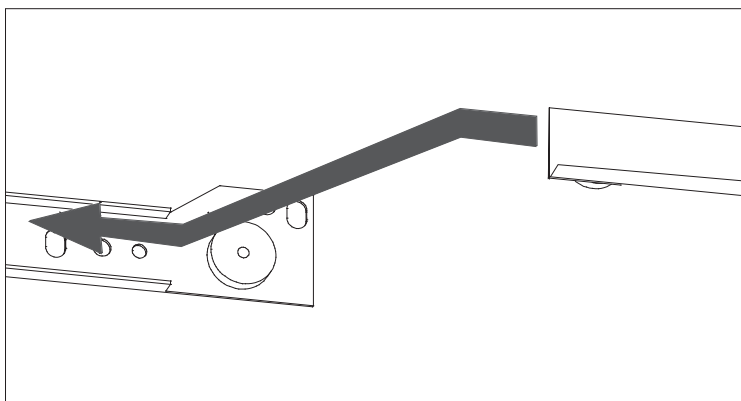

17

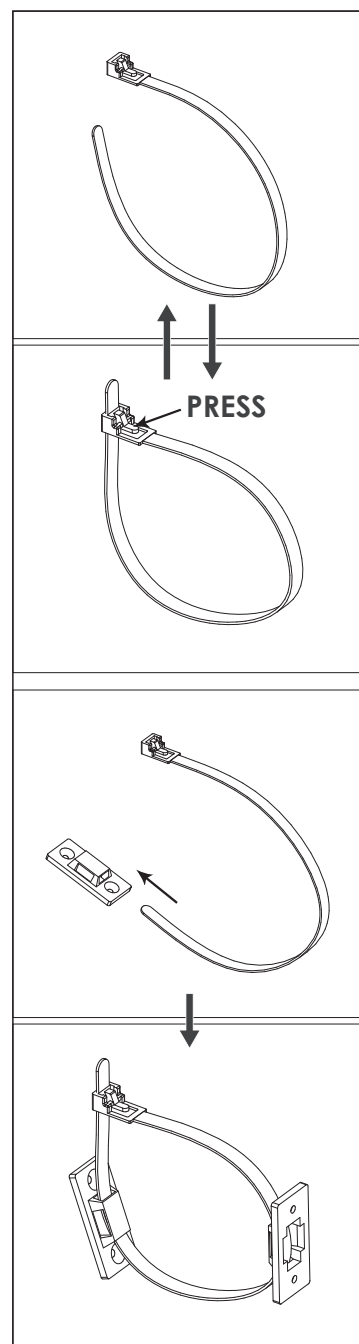
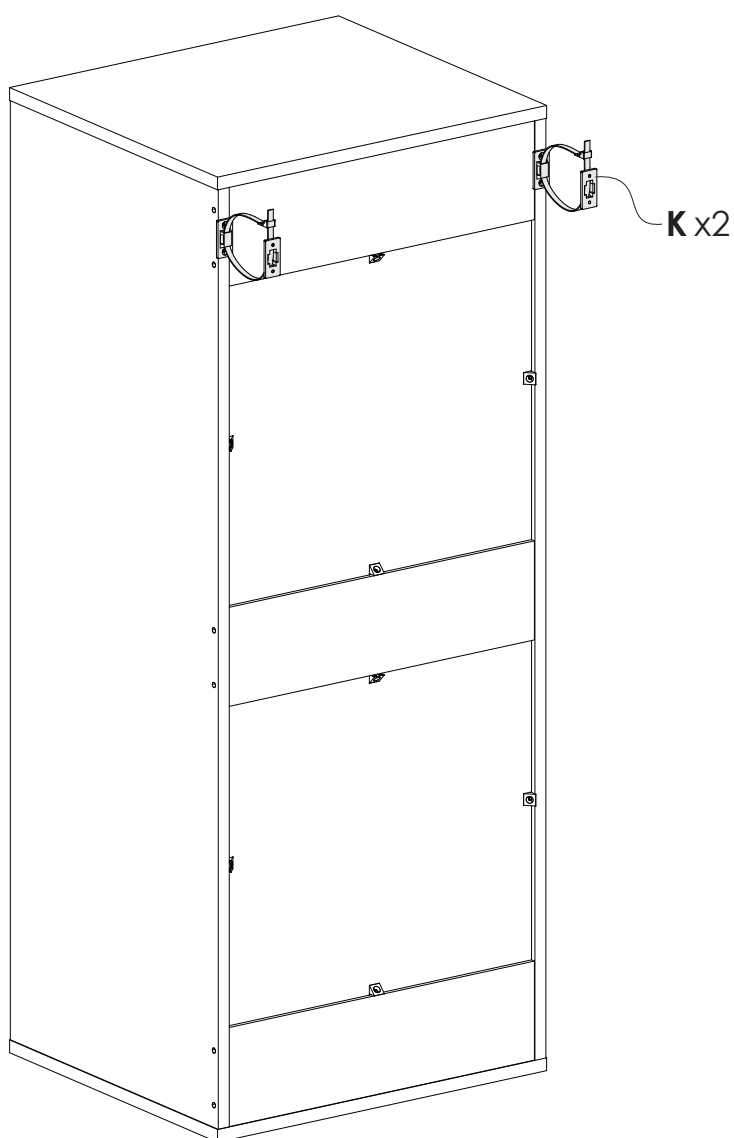
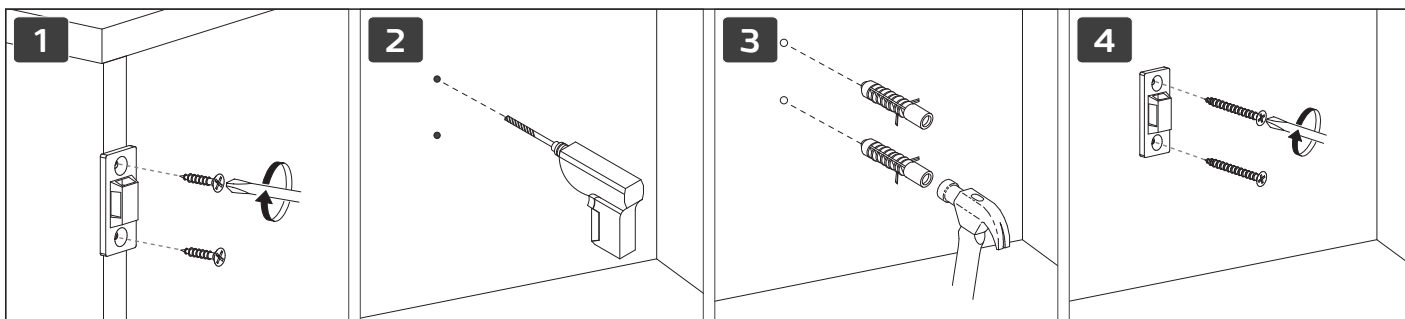
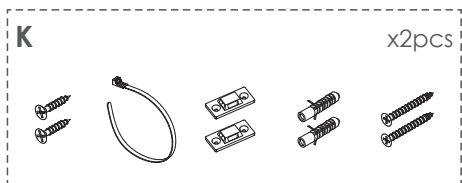

18

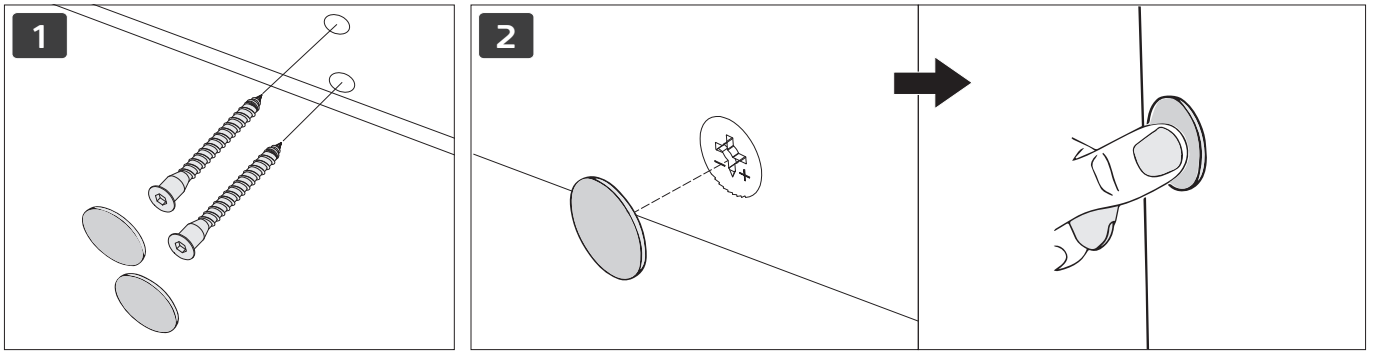

Add L fittings to all exposed holes on the front of the product

