



HALF CIRCLE RACK PR9



If you need assistance, please call 1-877-ENCLUME
Enclume Design Products
24 Colwell Street, Port Hadlock, WA 98339

Enclosed you will find everything needed for the assembly and use of your wall rack. Two people make assembly and installation easier. The parts and hardware included are:

Hardware included:

- 1 – $\frac{3}{8}$ x $\frac{1}{2}$ " Button Head Screw
- 3 – 2" Lag Screw
- 1 – $\frac{7}{32}$ " Hex Key
- Toggler Kit

Components included:

- 1 – Half Circle Body
- 1 – Arm
- 6 – Angled Pot Hooks

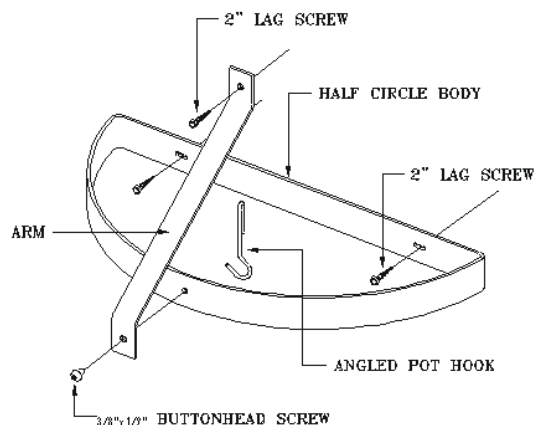

ASSEMBLY AND INSTALLATION INSTRUCTIONS

Rack Assembly

- 1) If your rack is plated it is best to keep the tissue on during installation to avoid fingerprinting.
- 2) Attach the arm to the rack body using the button head screw and wrench provided.
- 3) We recommend that you anchor your rack into the solid wood wall stud. Carefully measure the area where the rack is to be hung and install the ceiling screw hooks directly into the wood joists. If it is not convenient to hang your rack directly into wood joists you may use the included DRYWALL anchors enclosed with your rack. See Toggler® brand manufacturer recommendations for weight limits included in the instructions in the Toggler kit.
- 4) Your rack is now ready to use. Distribute your cookware uniformly around the rack.

WARNING: It is important that your wall rack is assembled correctly. If the unit is assembled or used incorrectly, it could become unstable and collapse, possibly causing injury.

LIMITED WARRANTY: This product is warranted to be free of material defects, other than that from normal use, for a period of five years from the date of purchase. Customer's exclusive remedy shall be the repair or replacement of the defective product and shall be subject to the following conditions: (1) notice of any defect is received by Enclume within the warranty period and (2) customer returns the defective product to Enclume Design Products, 24 Colwell St., Port Hadlock, WA 98339, postage prepaid within 20 days following a return authorization number (which may be obtained by telephoning the number at the top of this instructions) being provided to the customer by Enclume. There are no other warranties, expressed or implied. THERE ARE NO WARRANTIES OF MERCHANTABILITY OR FITNESS FOR A PARTICULAR PURPOSE. ENCLUME SPECIFICALLY DISCLAIMS ANY AND ALL INCIDENTAL OR CONSEQUENTIAL DAMAGES ARISING OUT OF THE PURCHASE OR USE OF ENCLUME'S PRODUCTS.