

Read this instruction carefully. See hardware and furniture part list for guidance. Be sure all parts are complete, before you assemble. Place all wooden furniture parts on a clean and flat soft surface to prevent from being scratched. Follow the figure to start assembling.

CAUTIONS : 1. Do not FULLY - TIGHTEN the nut or nut bolt until all nut or bolt is ready assembled.
 2. Do not OVER - TIGHTEN the nut or bolt to avoid causing damages to the thread.
 3. Keep all hardware parts out of reach of children.

NOTE : THE LIST AND QUANTITY SHOWN ARE FOR 1 UNIT ASSEMBLY.

Tool needed : Screwdriver (not provider).

PART LIST			
ITEM	DESCRIPTION	BOX	QTY
A	HEADBOARD	1	1 PC
B	HEADBOARD LEG	4	2 PCS
C	FOOTBOARD	2	1 PC
D	FOOTBOARD LEG	4	2 PCS
E	SIDE RAIL	2	2 PCS
F	SIDE RAIL SUPPORT WOOD	2	2 PCS
G	CENTER RAIL	2	1 PC
H	CENTER SUPPORT LEG	2	3 PCS
I	BED SLAT	3	1 SET

HARDWARE LIST (BOX : 2)		
ITEM	DESCRIPTION	QTY
1	JCBC BOLT M6 x 40mm	22 PCS
2	M6 FLAT WASHER	14 PCS
3	M6 SPRING WASHER	14 PCS
4	WOOD SCREW M4 x 38mm	9 PCS
5	WOOD SCREW M4 x 20mm	2 PCS
6	WOOD DOWEL M8 x 30mm	12 PCS
7	M4 ALLEN KEY (BALL SHAPE)	1 PC
8	M5 ALLEN KEY (BALL SHAPE)	1 PC

STEP 1

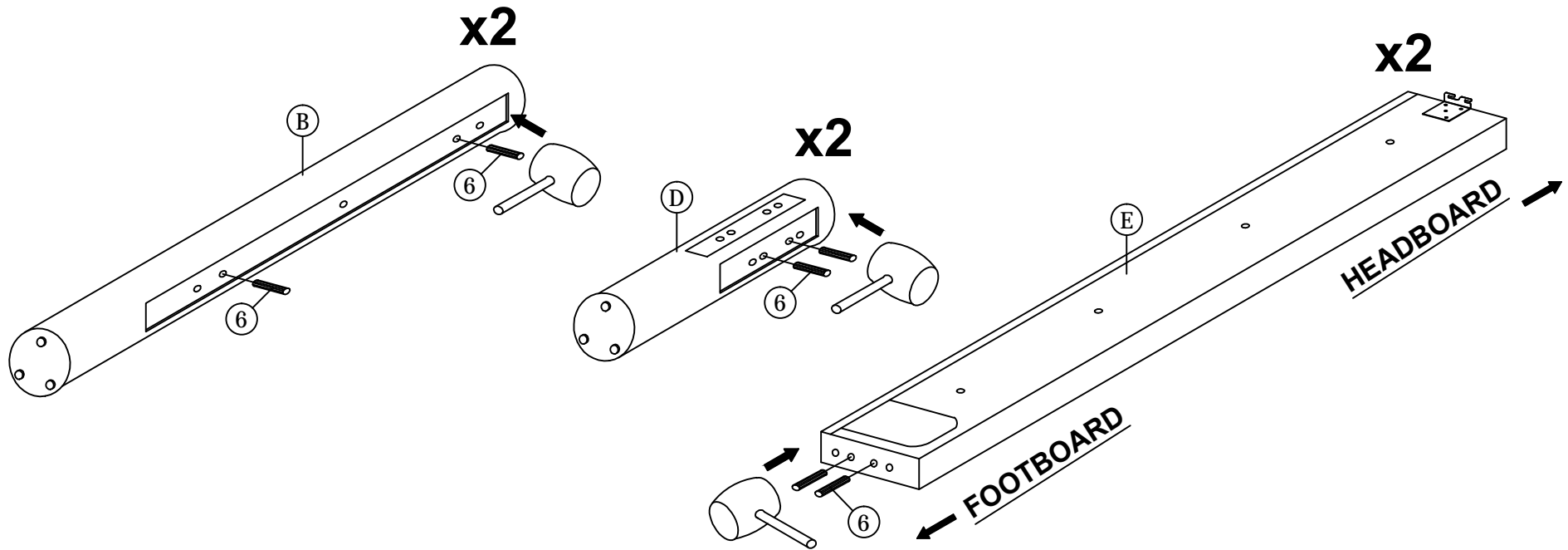

ASSEMBLY INSTRUCTIONS

STEP 2

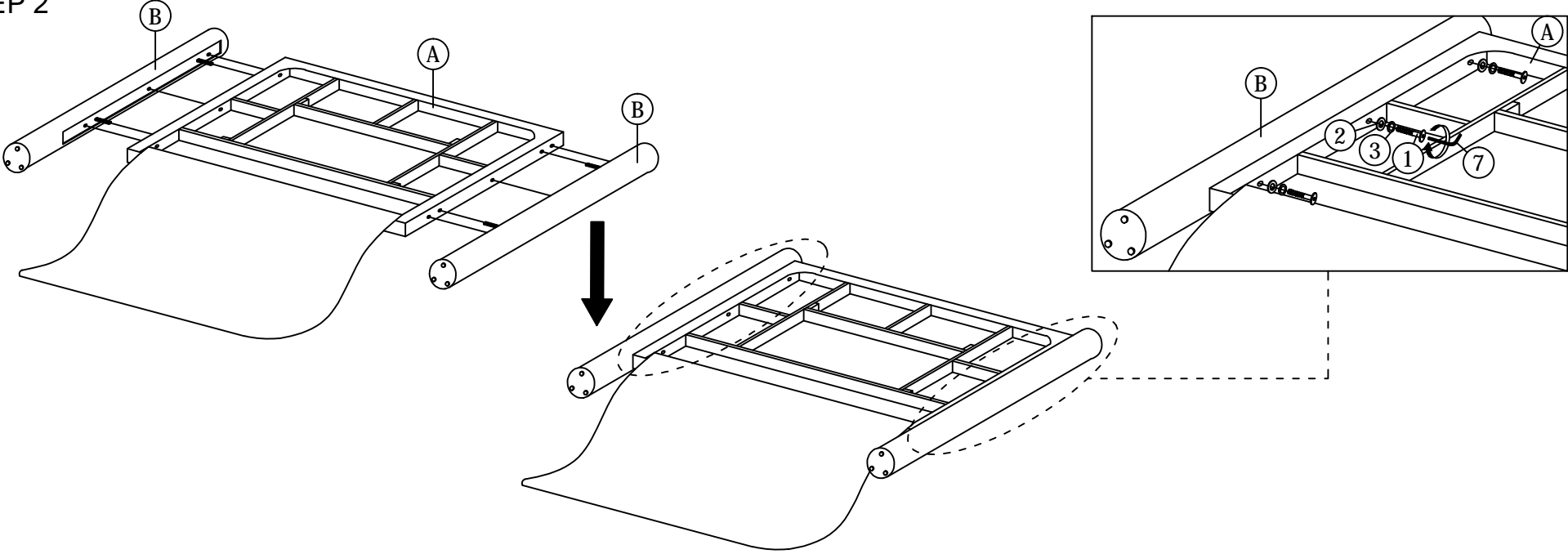

STEP 3

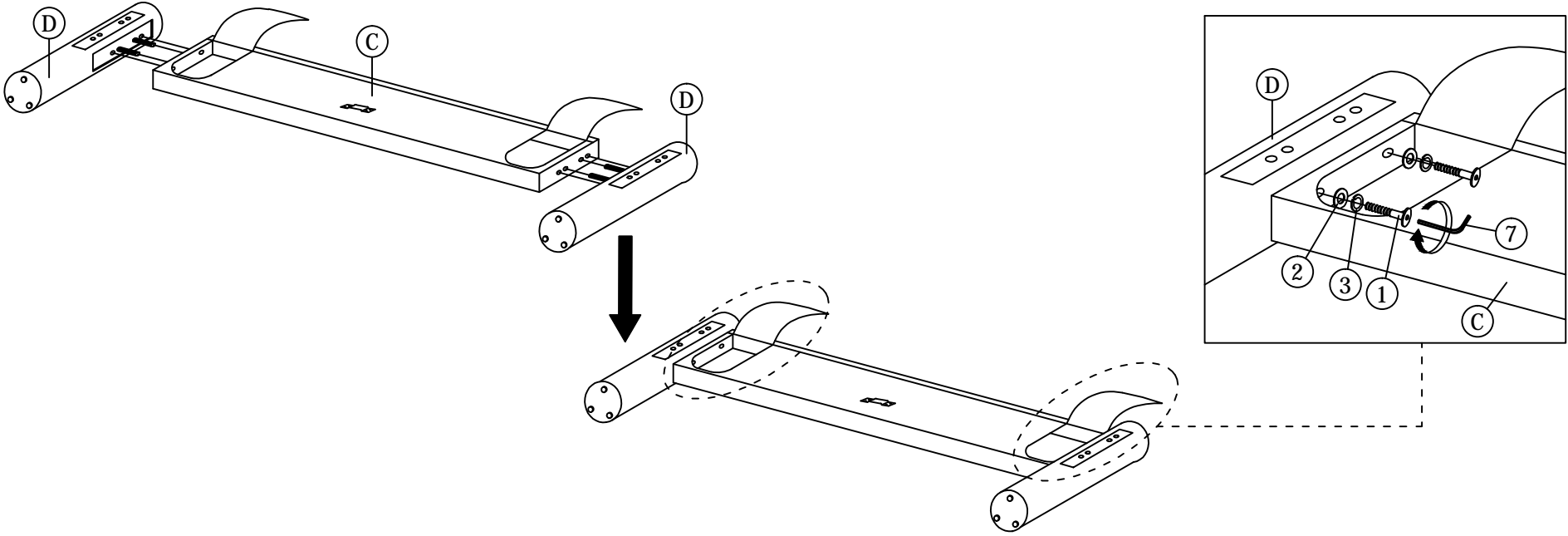

ASSEMBLY INSTRUCTIONS

STEP 4

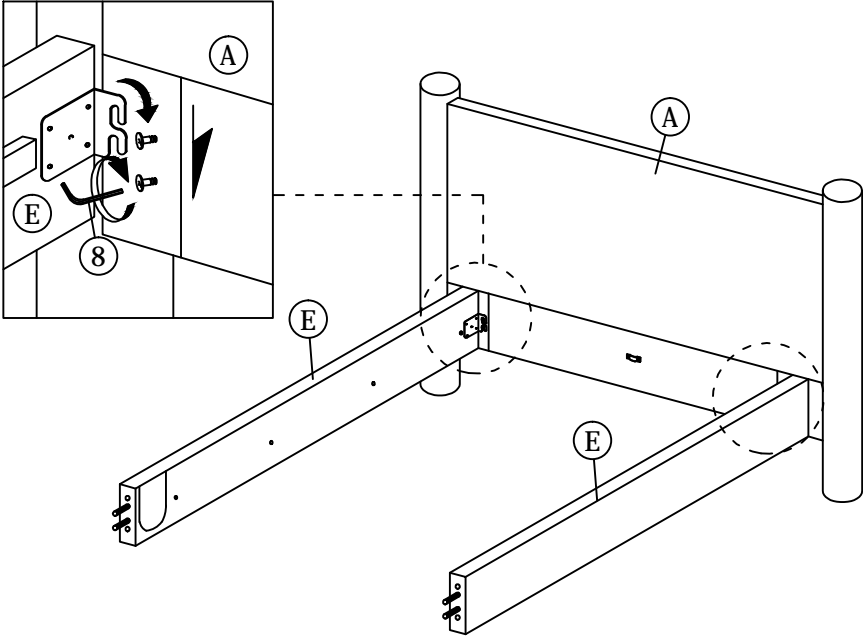

STEP 5

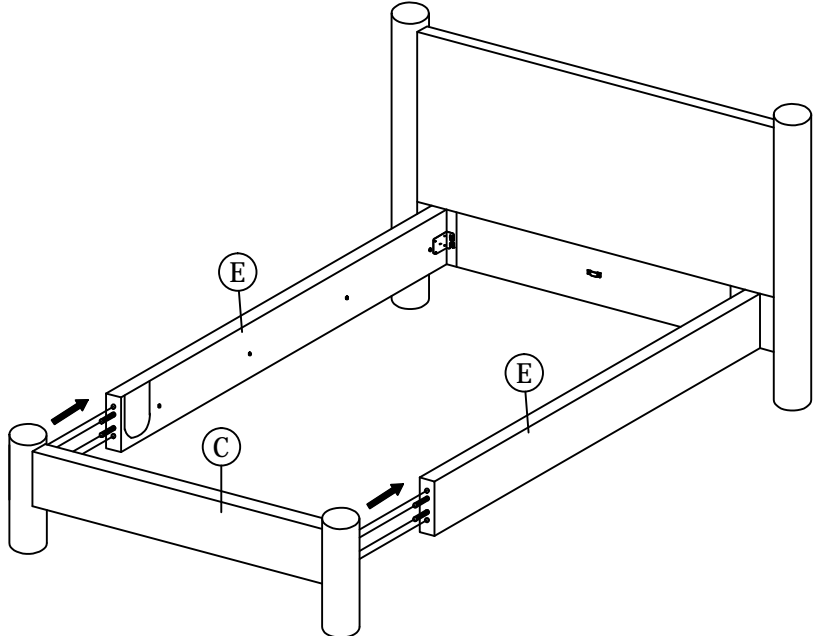

STEP 6

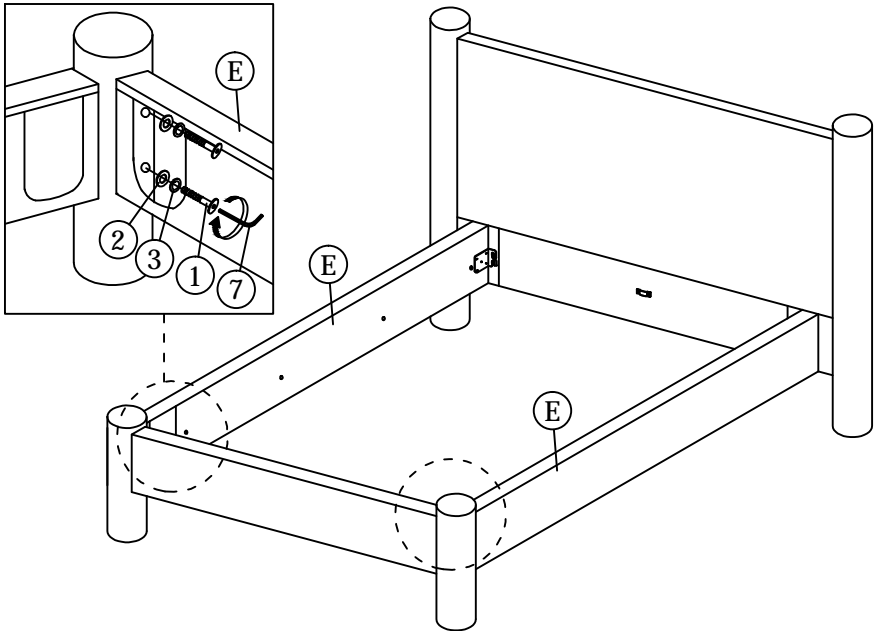

STEP 7

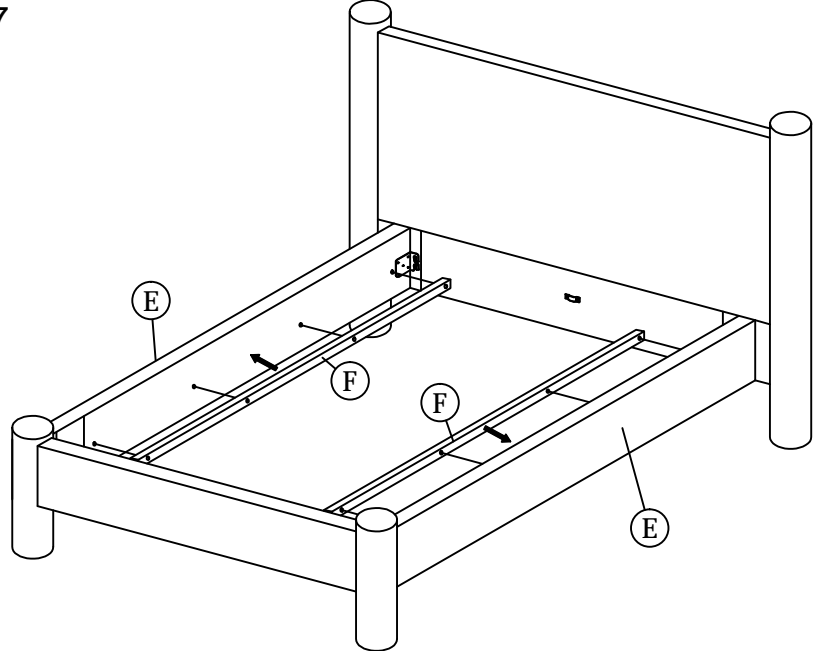

ASSEMBLY INSTRUCTIONS

STEP 8

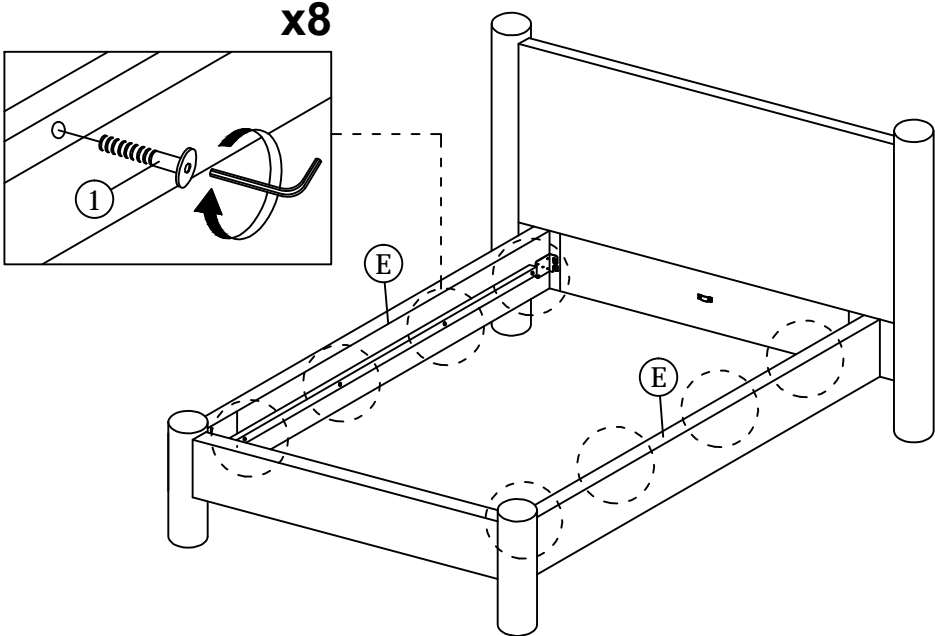

STEP 9

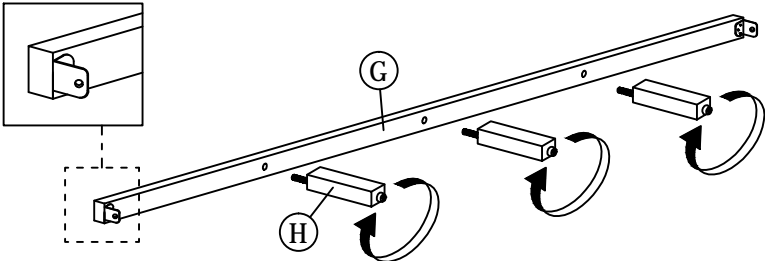

STEP 10

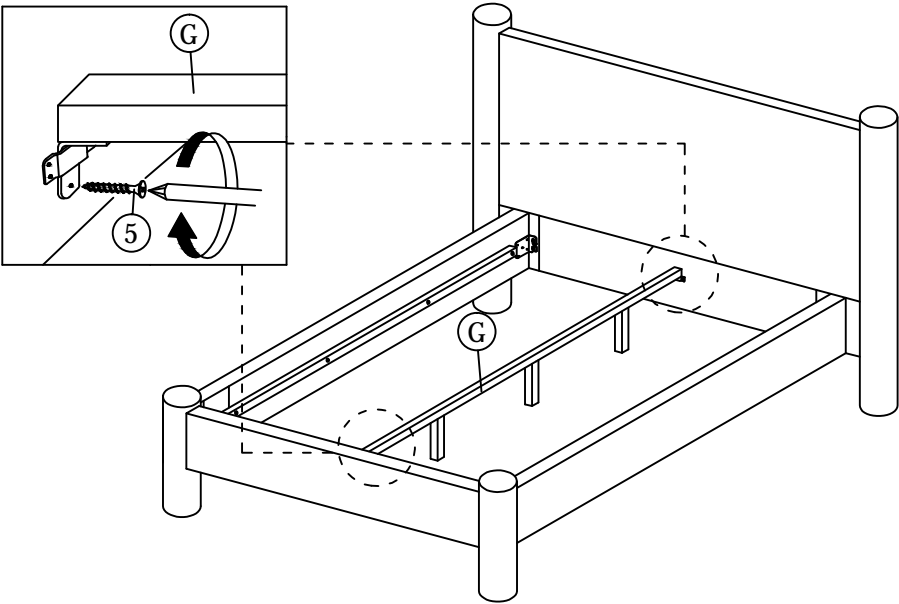

STEP 11

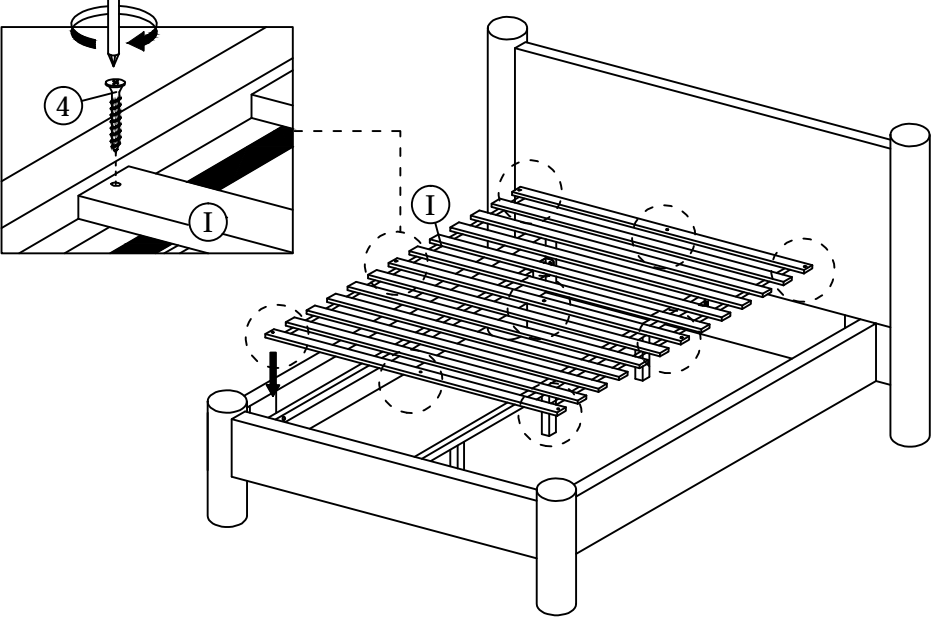

ASSEMBLY INSTRUCTIONS

5 OF 5

STEP 12

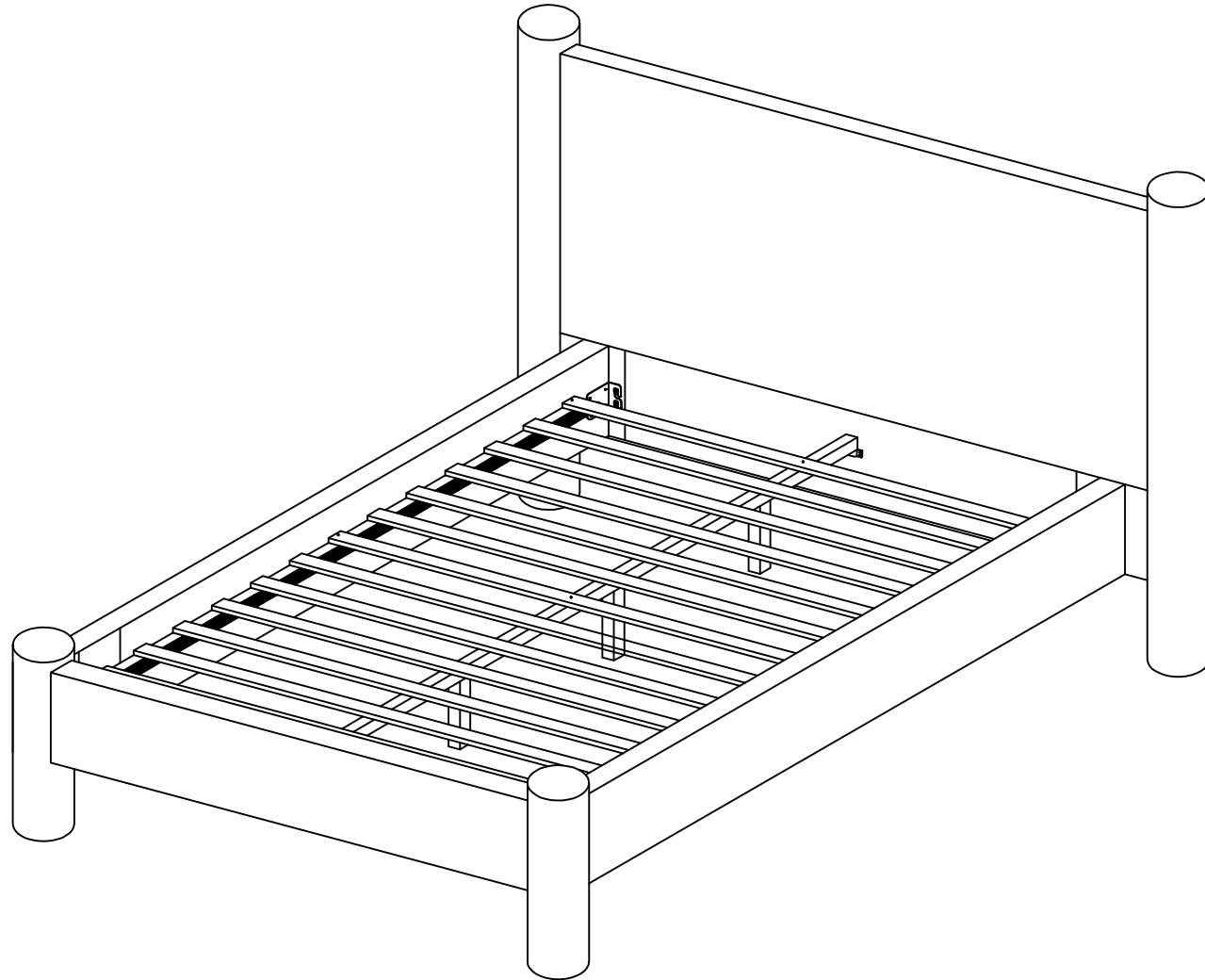

* When moving the bed position, the center support legs must be adjust to be straight to avoid any broken problem.