

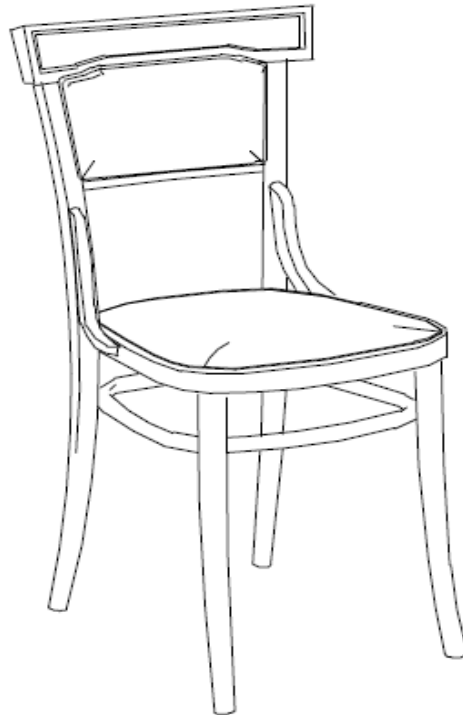







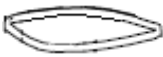
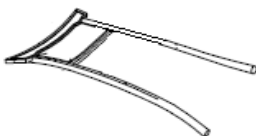

Assembly Instructions





PARTS LIST (FOR 2 NOS. OF CHAIR):

P1 SEAT		2 PCS
P2 RING STRETCHER		2 PCS
P3 BACK LEG FRAME		2 PCS
P4 STUMPS-RIGHT		2 PCS
P5 STUMPS-LEFT		2 PCS
P6 FRONT LEG		4 PCS

HARDWARE LIST (FOR 2 NOS. OF CHAIR):

H1 M6 x 35mm JCBC SCREW		20 PCS
H2 M6 x 80mm JCBC SCREW		4 PCS
H3 SPRING WASHER		8 PCS
H4 FLAT WASHER		8 PCS
H5 ALLEN KEY		1 PC
H6 WOOD BUTTON		8 PCS
H7 METAL BRACKET		4 PCS
H8 CSK SCREW M3.5 x 16mm		8 PCS

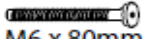

STEP 1

H2 x 2	 M6 x 80mm
H3 x 2	
H4 x 2	

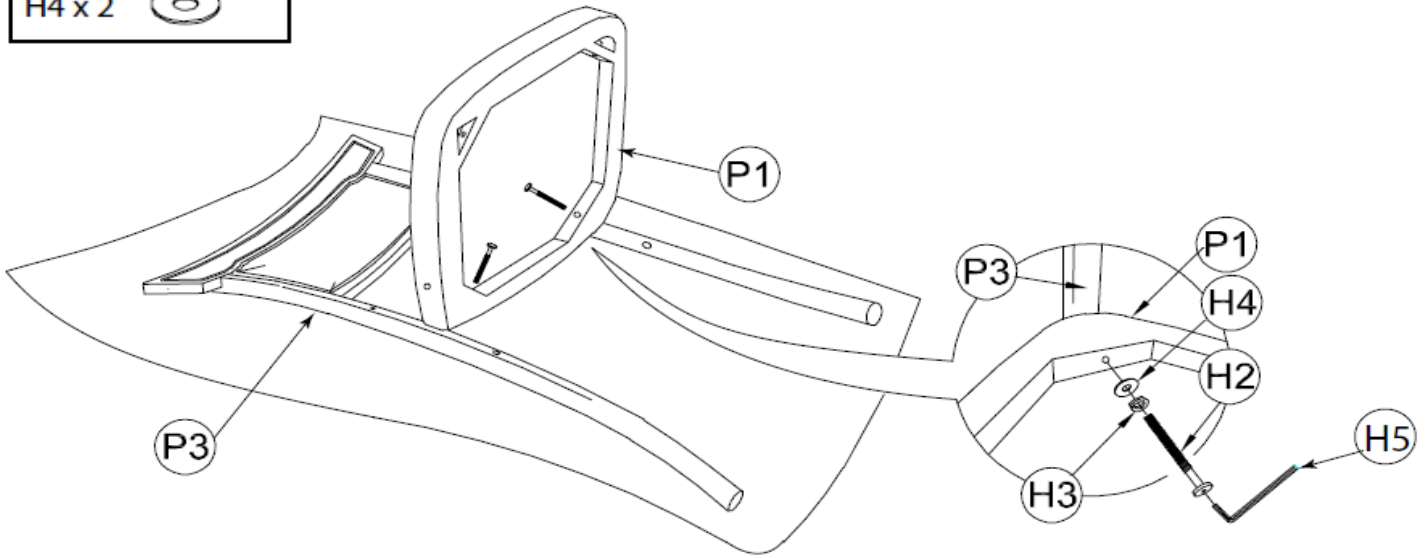
Assemble the Seat (P1) into the Back Leg Frame (P3) by Bolts (H2) with Spring Washer (H3) & Flat Washer (H4) and aligning the bolts into holes in the seat frame through the nuts in the back legs. Tighten the bolt using Allen Key (H5).



STEP 2

H1 x 2	 M6 x 35mm
H3 x 2	
H4 x 2	

Assemble the Front Legs (P6) into the Seat Frame (P1) by aligning Bolts (H1) with Spring Washer (H3) & Flat Washer (H4). Use Allen Key (H5) to tighten the bolt, but DO NOT fully Tighten it yet.

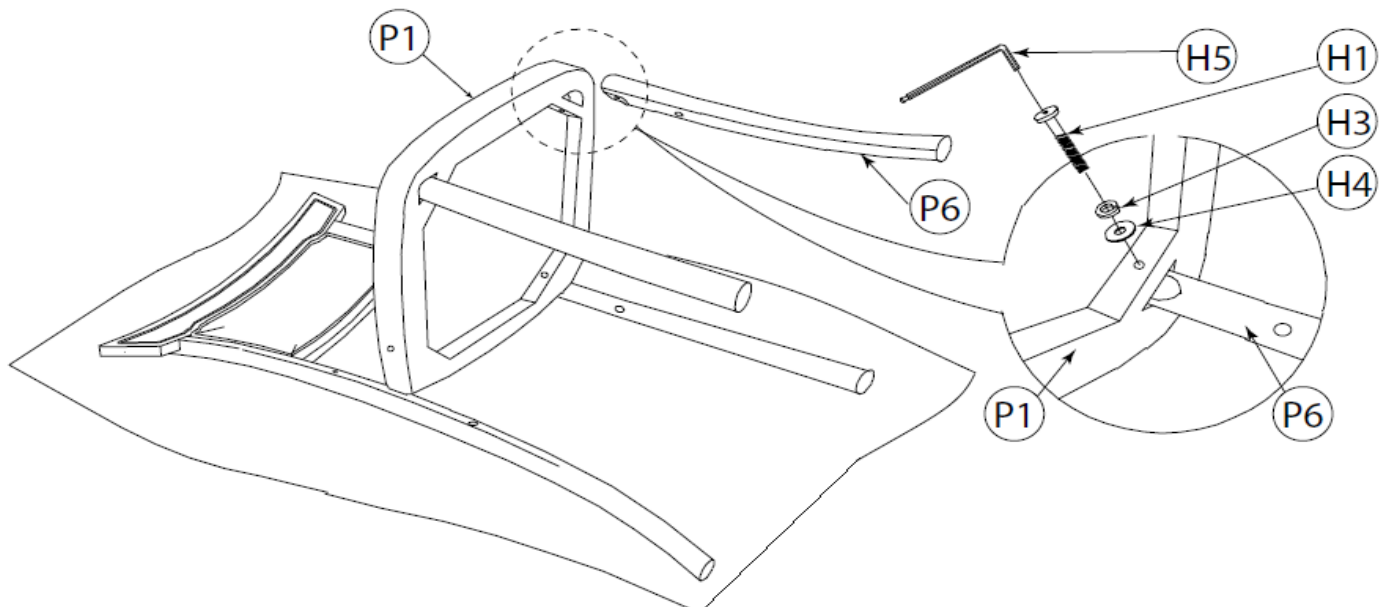

STEP 3

H1 x 4
M6 x 35mm

Assemble the Ring Stretcher (P2) into the Front Legs (P6) and both Back Legs by using Bolts (H1). Tighten the bolt using Allen Key (H5).

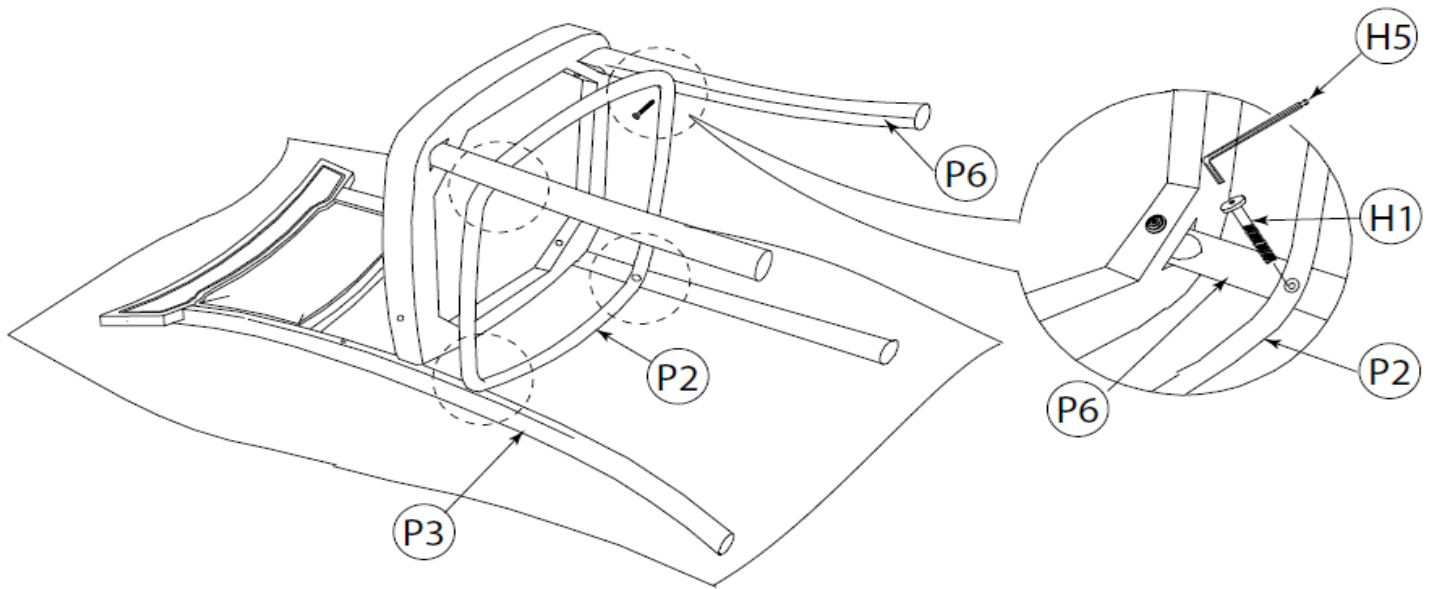

STEP 4

H1 x 2
M6 x 35mm

Install Stump (P4-R) to each Right side by aligning Bolts (H1) into the hole in the Stumps to the nuts in the Back Leg (P3) & the Right side of the Seat frame (P1).
Full Tighten all the bolts in the chair.

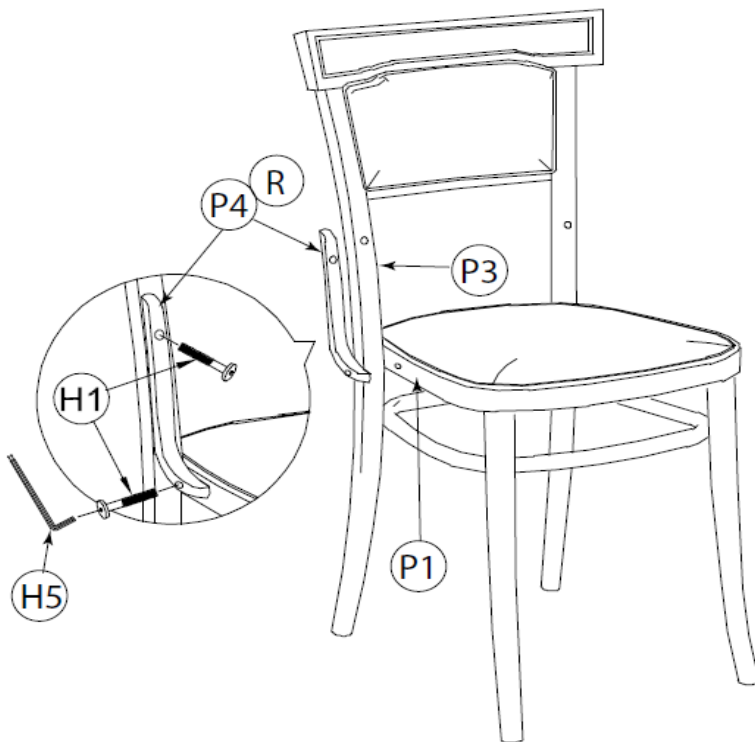

STEP 5

H1 x 2
M6 x 35mm

Install Stump (P4-L) to each Left side by aligning Bolts (H1) into the hole in the Stumps to the nuts in the Back Leg (P3) & the Left side of the Seat frame (P1).
Full Tighten all the bolts in the chair.

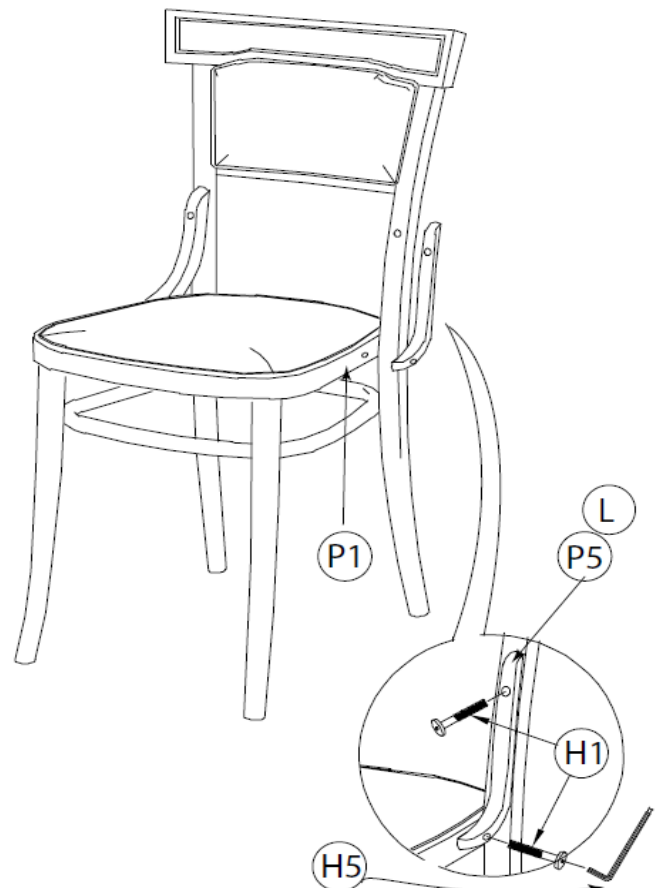

STEP 6

H6 x 4 

Cover the screw holes with Wood Button (H6)

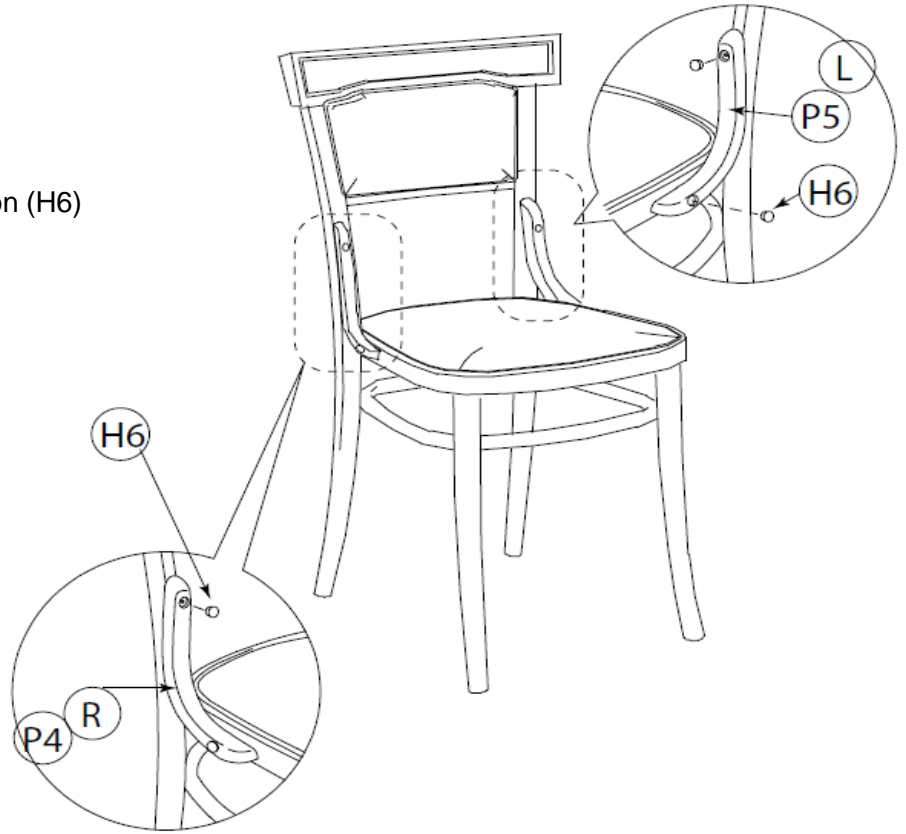

STEP 7

H7 x 1 

H8 x 2 
M3.5 x 16mm

To add strengthening the Chair legs to the seat frame, mount the Metal angle (H7) by aligning screw (H8) and tighten it using a household screwdriver.

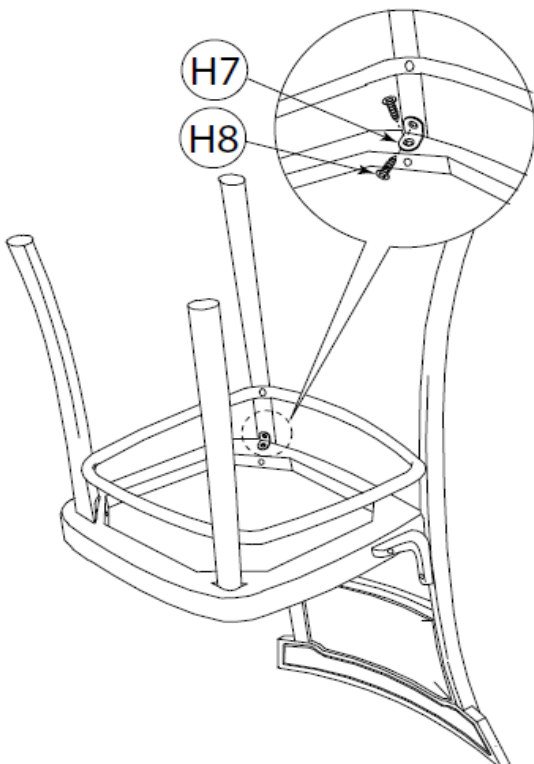

STEP 8

H7 x 1 

H8 x 2 
M3.5 x 16mm

Mount the Metal angle (H7) onto the other side of leg by aligning screw (H8) and tighten it using a household screwdriver.

