















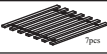



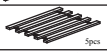



ASSEMBLY INSTRUCTION

NO	PART LIST	QTY
1	 BACK REST 1PC	1PC
2	 SIDE PANEL (L) 1PC	1PC
3	 SIDE PANEL (R) 1PC	1PC
4	 FRONT SIDE RAIL 1PC	1PC
5	 BACK SIDE RAIL 1PC	1PC
6	 LEG 4PCS	4PCS
7	 SLAT 2 SET	2 SET
8	 TRUNDLE FRONT RAIL 1PC	1PC
9	 TRUNDLE BACK RAIL 1PC	1PC
10	 TRUNDLE SIDE RAIL 2PCS	2PCS
11	 SLAT 2 SET	2 SET
12	 SLAT SUPPORT 3PCS	3PCS
13	 CASTOR 6PCS	6PCS
ITEM	HARDWARE	QTY
A	 JCBB SCREW M8 x 20MM 16PCS	16PCS
B	 JCBC SCREW M6 x 35MM 4PCS	4PCS
C	 JCBC SCREW M6 x 50MM 16PCS	16PCS
D	 SPRING WASHER M6 x 13MM 16PCS	16PCS
E	 FLAT WASHER M6 x 19MM 4PCS	4PCS
F	 FLAT WASHER M6 x 13MM 12PCS	12PCS
G	 SCREW M4 x 16MM 24PCS	24PCS
H	 SCREW M4 x 32MM 16PCS	16PCS
I	 L - KEY M4 x 65MM 1PC	1PC
J	 L - KEY M5 x 65MM 1PC	1PC

STEP 1

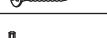

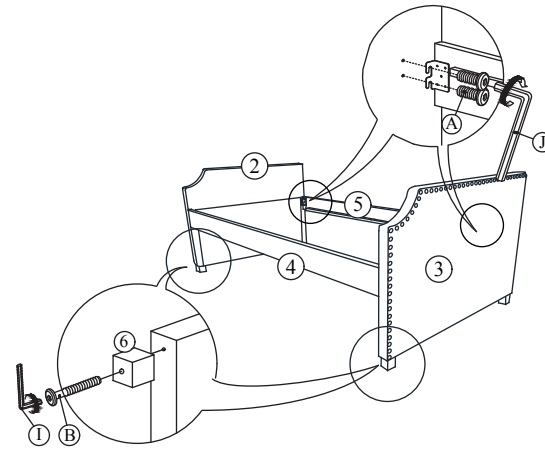
STEP 2

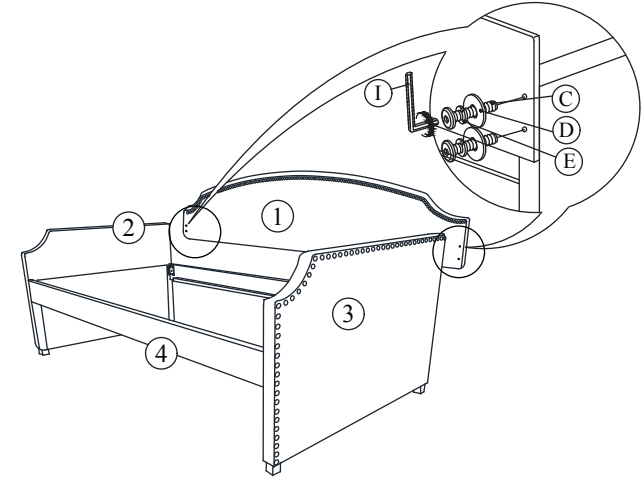

STEP 3

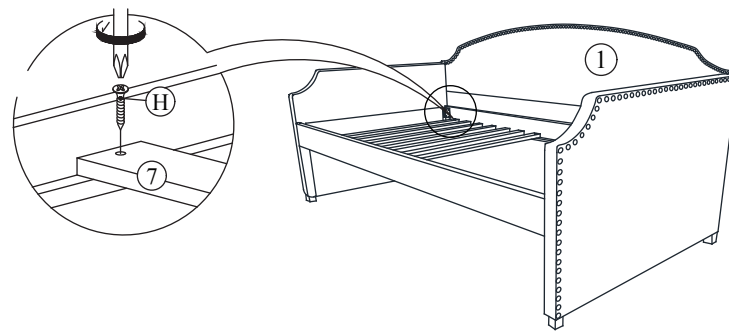

STEP 4

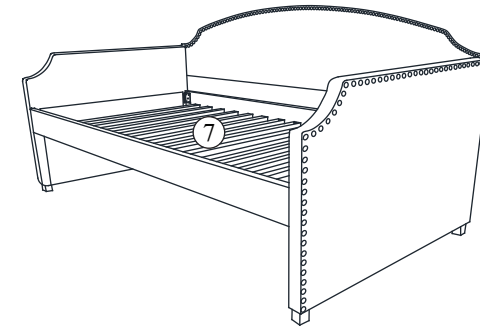

STEP 5

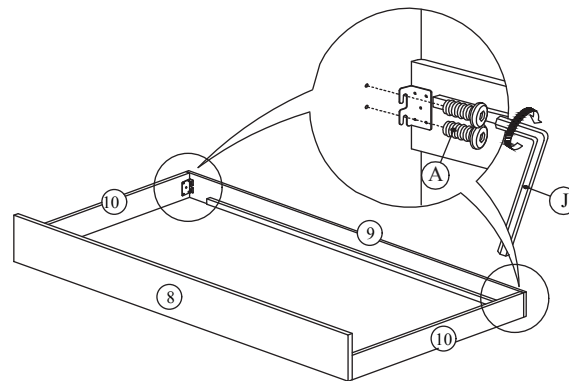

STEP 6

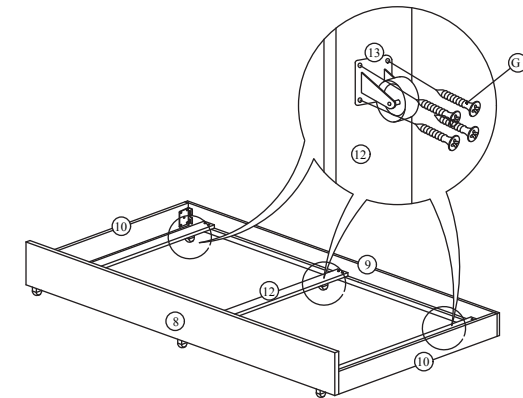

Please do not tighten the hardware until the entire assembly is completed.

ASSEMBLY INSTRUCTION

STEP 7

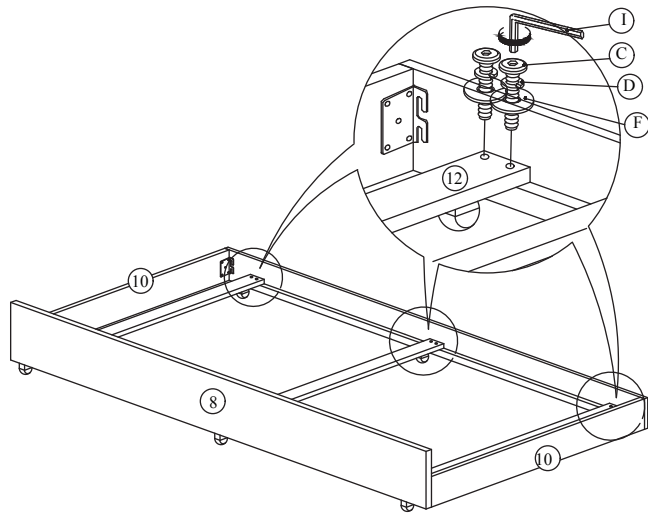

STEP 8

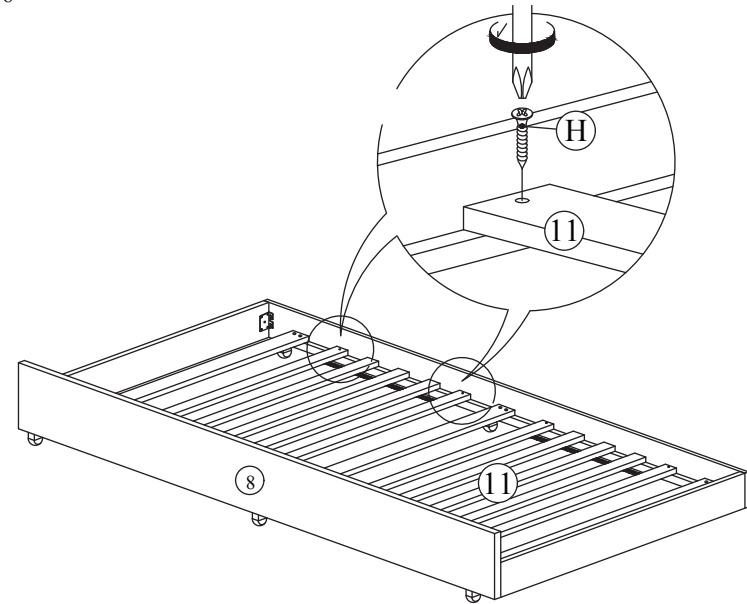

STEP 9

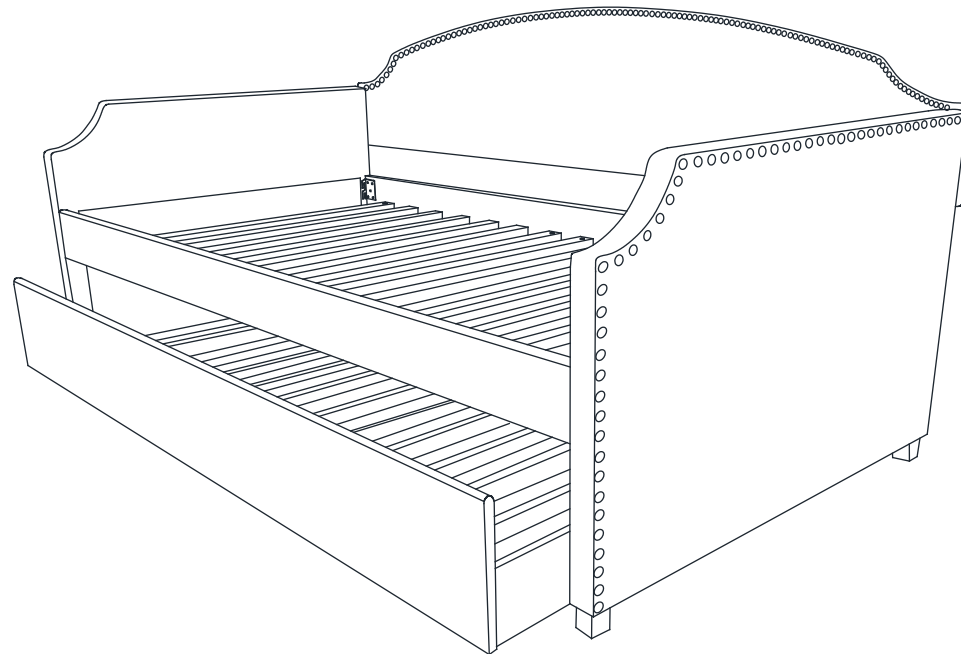

ASSEMBLY
COMPLETE

Please do not tighten the hardware until the entire assembly is completed.