

# Electric Flip Down / Swivel Ceiling TV Mount

MOUNT-E-FD75C-S

Assembly Manual

---

**\*\* DO NOT RETURN ITEM \*\***

---

# Contact Us First!

Our friendly US-Based Product Support Team to help!



## We're Here For You

Monday-Friday from 7am-7pm CST  
Saturday 8am-4pm CST

US-Based Customer Support from Trained Professionals



**Email Us**

[help@vivo-us.com](mailto:help@vivo-us.com)



**Chat with Live Agent**

[www.vivo-us.com](http://www.vivo-us.com)



**Give Us a Call**

309-278-5303 ext. 1

---

## Assembly Video Available

*Navigate to the middle of the product page to watch as our product specialists walk you through the assembly process.*

[www.vivo-us.com/products/mount-e-fd75c-s](http://www.vivo-us.com/products/mount-e-fd75c-s)



**WATCH NOW**



**PLEASE READ**



### General Notice:

If you do not understand these directions, or if you have any doubts about the safety of the installation, please contact our product support team at 309-278-5303 or [help@vivo-us.com](mailto:help@vivo-us.com) for further assistance. Check carefully to make sure there are no missing or defective parts. Improper installation may cause damage or serious injury. Do not use this product for any purpose that is not explicitly specified in this manual. Do not exceed weight capacity. We cannot be liable for damage or injury caused by improper mounting, incorrect assembly or inappropriate use.

### Missing Parts:

If any parts are received damaged / defective OR you are missing a part, please reach out to us ***within 30 days of product delivery to have it replaced at no cost.*** **PLEASE NOTE:** Failure to report missing parts within the stated time frame ***may result in denial of free replacement.***

### Returns:

We offer a hassle-free 30 day return on all products. Contact customer support at 309-278-5303 or [help@vivo-us.com](mailto:help@vivo-us.com). Please note: For items ordered in error or no longer needed, the return shipping charges will be at the buyer's expense.

## Product Specific Warnings:



### WARNING: CHOKING HAZARD

SMALL PARTS - NOT FOR CHILDREN UNDER 3 YEARS. ADULT SUPERVISION IS REQUIRED.



### DO NOT EXCEED WEIGHT CAPACITY

FAILURE TO DO SO MAY RESULT IN SERIOUS INJURY.



### ELECTRICAL SAFETY INSTRUCTIONS

THIS PRODUCT IS POWERED BY ELECTRICITY. IN ORDER TO AVOID BURNS, FIRE AND ELECTRIC SHOCK, PLEASE READ THE FOLLOWING INSTRUCTIONS CAREFULLY.

- DO NOT CLEAN PRODUCT WHILE POWER IS CONNECTED.
- DO NOT DISASSEMBLE OR REPLACE COMPONENTS WHILE POWER IS CONNECTED.
- NEVER OPERATE THE SYSTEM WITH A DAMAGED CORD OR PLUG.  
PLEASE CONTACT YOUR SELLER TO REPLACE DAMAGED PARTS.
- NEVER OPERATE SYSTEM IN DAMP ENVIRONMENTS OR IF ANY ELECTRICAL COMPONENTS HAVE MADE CONTACT WITH LIQUIDS.
- ALTERATIONS OF THE GIVEN POWER UNIT ARE NOT ALLOWED.
- OUTDOOR USE IS PROHIBITED.



### ELECTRICAL CABLE WARNING

DO NOT ROUTE ANY ELECTRICAL CABLES OR PLACE OBJECTS THROUGH THE FOLDING PORTION OF MOUNT. FAILURE TO FOLLOW THESE INSTRUCTIONS MAY RESULT IN ELECTRICAL SHOCK AND/OR SERIOUS PERSONAL INJURY.



### WARNING: PINCH POINT

DO NOT PLACE HANDS ON OR NEAR SUPPORT BARS. MOVING PARTS CAN CRUSH AND CUT. FAILURE TO FOLLOW THESE INSTRUCTIONS MAY RESULT IN SERIOUS PERSONAL INJURY.



### WARNING: DO NOT INSTALL INTO DRYWALL ALONE

VERIFY YOUR WALL CONSTRUCTION. USE WOOD STUDS TO MOUNT. We include mounting for brick and concrete walls. If unsure, please contact us at [vivo-us.com](mailto:vivo-us.com), email at [help@vivo-us.com](mailto:help@vivo-us.com), or call us at 309-278-5303.

## Package Contents

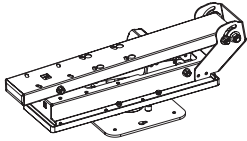

**A** (x1)  
Mount

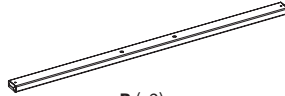

**B** (x2)  
Bracket Rail

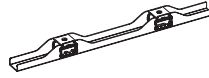

**C** (x2)  
VESA Bracket

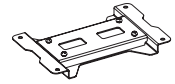

**D** (x1)  
Center Plate

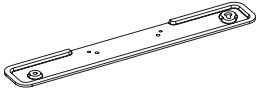

**E** (x2)  
Mounting Extension



**F** (x1)  
Template

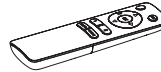

**G** (x1)  
Remote



**H** (x4)  
Cable Tie



**I** (x1)  
Power Adapter



**J** (x3)  
Cable Clip

## Included Hardware & Tools



**S-A** (x4)  
M4x8mm  
Screw



**S-B** (x4)  
Set Screw



**S-C** (x4)  
M6x10mm  
Screw



**S-D** (x4)  
M6x25mm  
Screw



**S-E** (x4)  
Large M6  
Washer



**S-F** (x4)  
M6 Nut



**W-A** (x4)  
ST6.3x55mm  
Screw

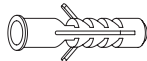

**W-B** (x4)  
Concrete  
Anchor



**W-C** (x2)  
Small M6  
Washer



**M-A** (x4)  
M6x14mm  
Screw



**M-B** (x4)  
M8x16mm  
Screw

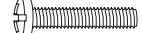

**M-C** (x4)  
M6x30mm  
Screw

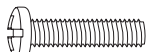

**M-D** (x4)  
M8x35mm  
Screw



**M-E** (x4)  
M8 Washer



**M-F** (x4)  
Small Spacer



**M-G** (x4)  
Large Spacer



**T-A** (x1)  
3mm Allen  
Wrench



**T-B** (x1)  
4mm Allen  
Wrench

## Tools Needed:



Ladder



Stud Finder



Pencil



Drill



Wrench



Phillips  
Screwdriver



Socket  
Wrench



Drill Bit  
Joist/Solid Wood: 3/16" (4.5mm)  
Concrete: 3/8" (10mm)

## Weight Capacity:



# User Guide

---

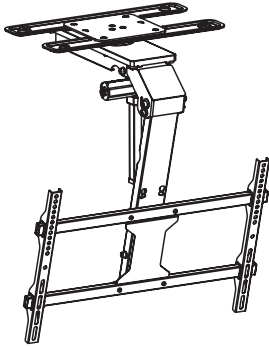

## Assembly & Installation

pg. 6-19

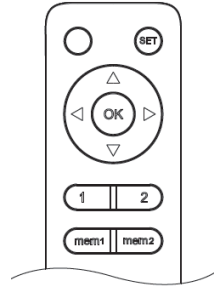

## Remote | Setup & Use

pg. 21-23

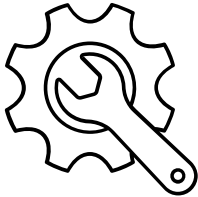

## Troubleshooting

pg. 25-26



## Tuya App | Setup & Use

pg. 27-34



## Voice Control | Setup & Use

Amazon Alexa & Google Home

pg. 35-38

## Assembly

### STEP 1

Attach Mounting Extensions (E) to Mount (A) using M6x10mm Screws (S-C). Tighten using 4mm Allen Wrench (T-B).

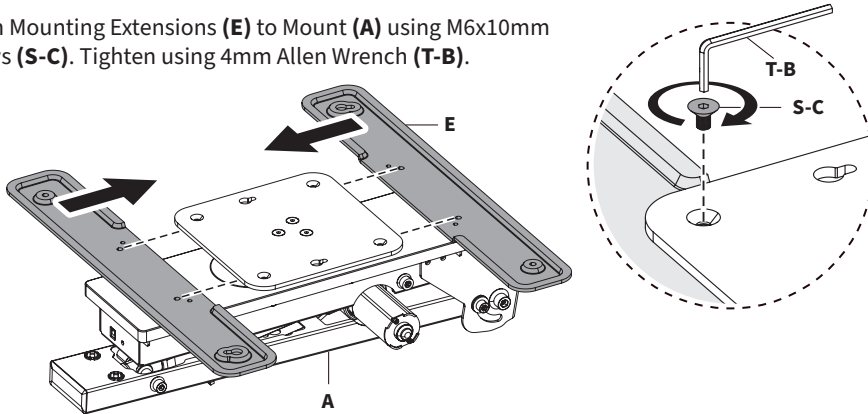

### STEP 2

1. With the Mount (A) flipped onto its back, plug Power Adapter (I) into the back of Mount.
2. Plug Power Adapter into a power source.

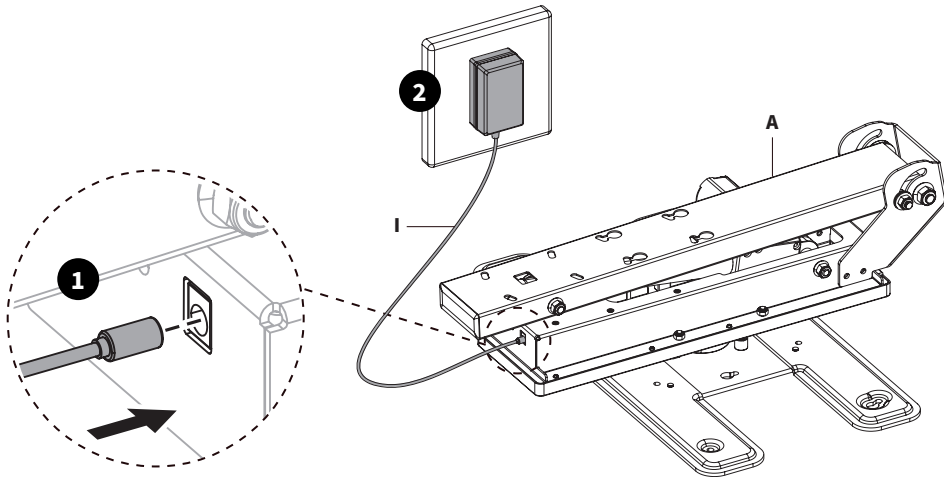

Be sure to plug the AC Adapter (I) into a power outlet **AFTER** connecting it to the Mount. Connecting the Adapter in the wrong order may cause a large spark.

### STEP 3

Following Remote Control instructions on page 22, use the Remote (**G**) to unfold the Mount (**A**). Once fully unfolded, unplug the Mount.

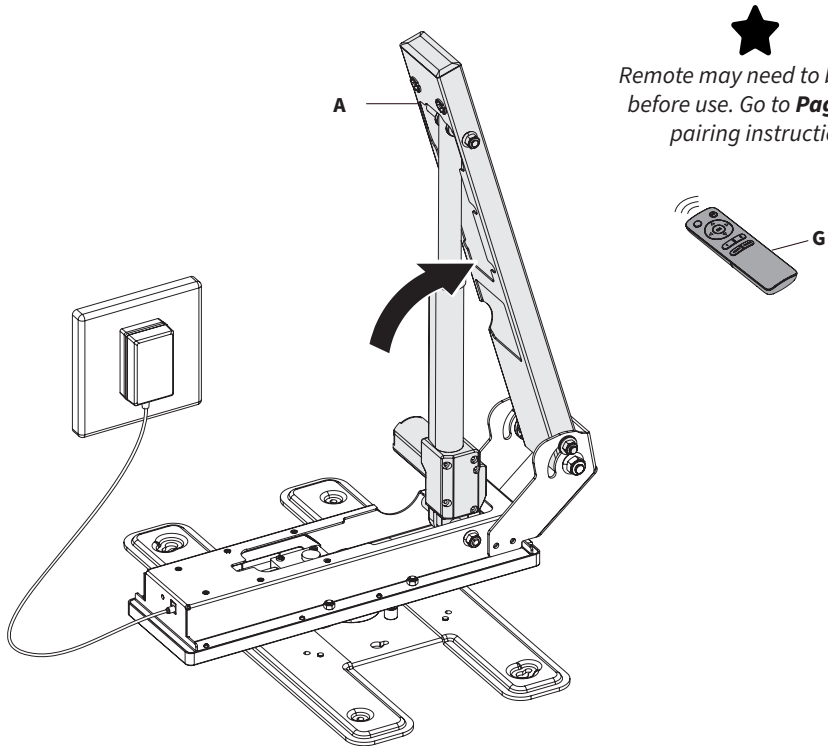

Remote may need to be paired before use. Go to **Page 23** for pairing instructions.

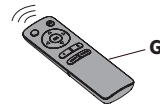

**\*\*WARNING\*\***

Keep hands clear of moving mount to prevent injury.

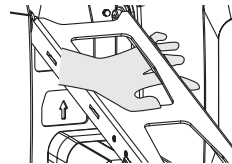

**\*\*\*Please Read Before Proceeding\*\*\***

## **Mounting Surface Options**

Check your mounting surface and choose the corresponding option below.

Option 1:  
**Wood Joist**  
Pages 9-10

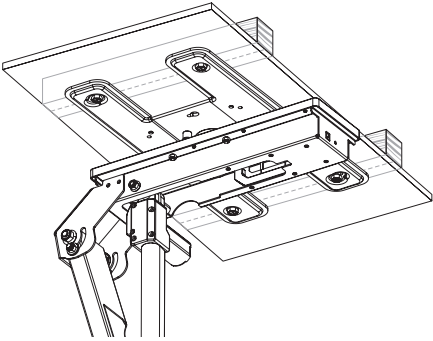

Option 2:  
**Solid Wood**  
Pages 11-12

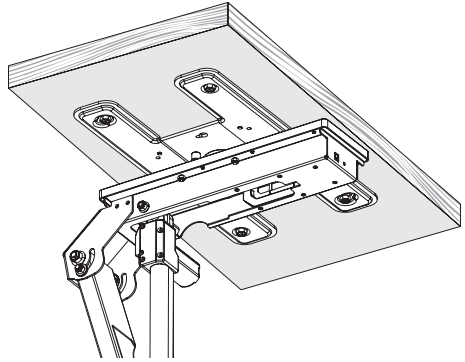

Option 3:  
**Concrete**  
Pages 13-14

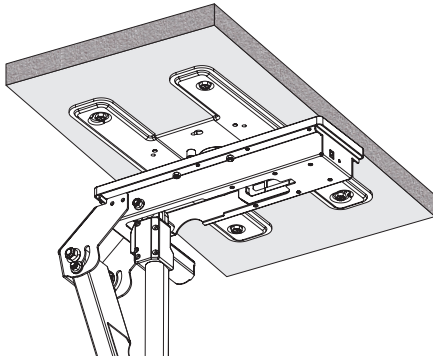

- Option 1 -  
**Wood Joist Mounting**

**STEP 3**

Identify wood joists in ceiling using a stud finder. Position Template (F) as shown and mark holes accordingly.

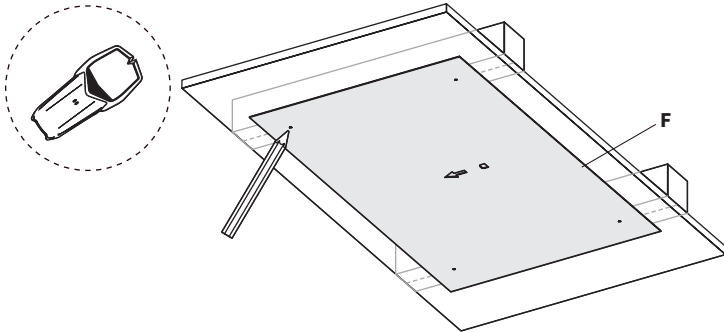

↑  
 ↓

Make sure the arrow on the Template points towards the end that will have your TV.

Use the infographic below to drill mounting holes at marked locations.

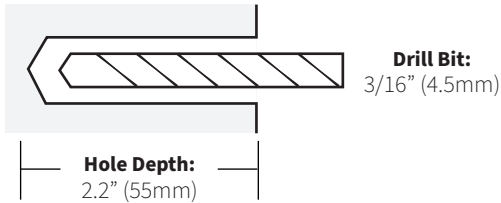
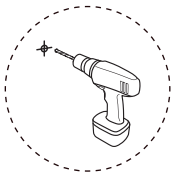

Using a socket wrench, insert ST6.3x55mm Screws (W-A) into the mounting holes that align with the **Keyhole Slots** of the Mount Extensions (E), leaving a 3mm gap from the ceiling.

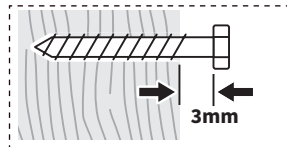
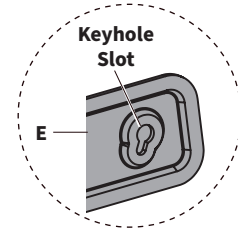
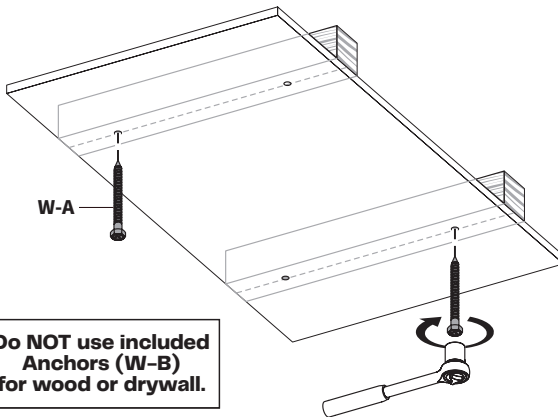

**Do NOT use included Anchors (W-B) for wood or drywall.**

**NOTE**  
**Near-to-Wall Installation**  
 If you are installing the Mount Assembly near a wall, make sure to leave enough room for the TV to fully swivel 90° left to right (180° total rotation) in both the up and down position.

## STEP 4

Raise the Mount Assembly so the ST6.3x55mm Screws (**W-A**) fit through the **Keyhole Slots** of the Mount Extensions (**E**). Turn Mount Assembly until supported by Screws.

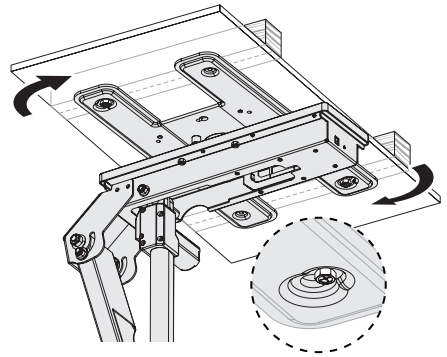
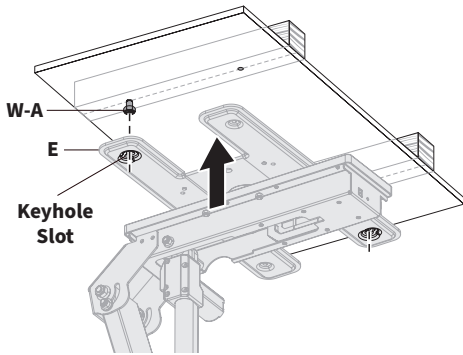

Secure Mount Assembly using the remaining ST6.3x55mm Screws (**W-A**) and M6 Washers (**W-C**). Tighten all Screws with a socket wrench.

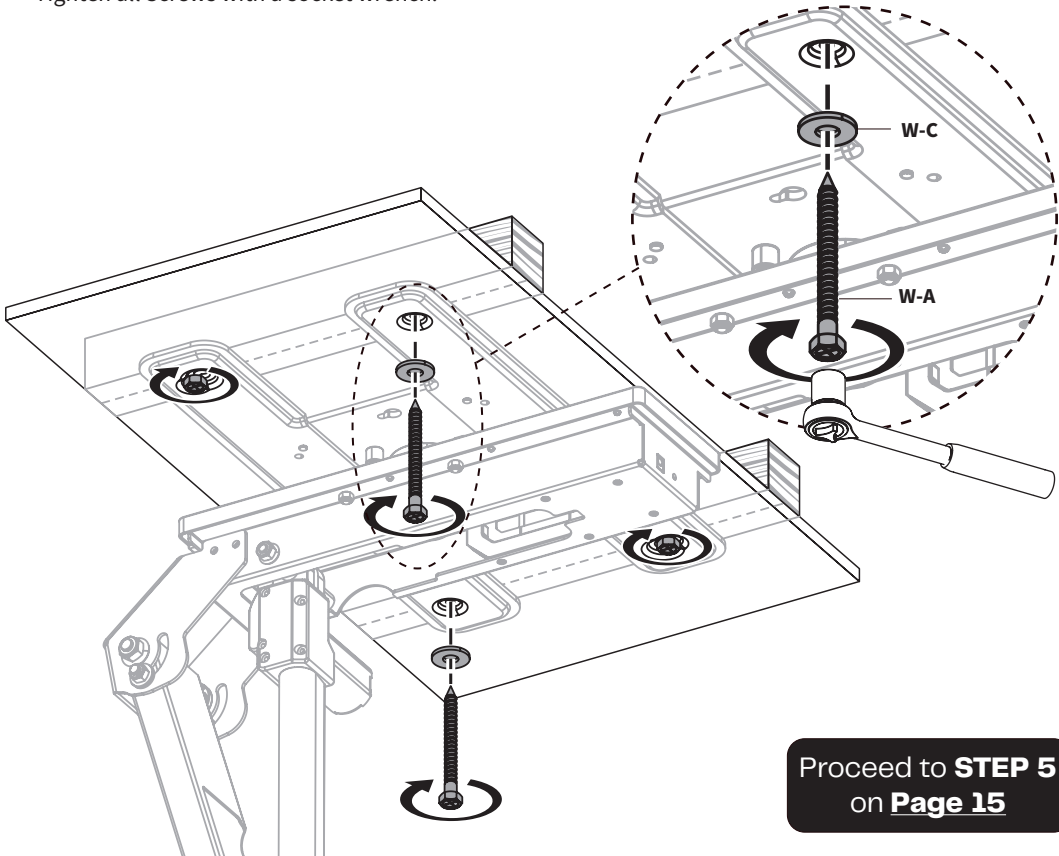

Proceed to **STEP 5**  
on **Page 15**

- Option 2 -  
**Solid Wood Mounting**

**STEP 3**

Position Template (**F**) in desired location and mark mounting holes.

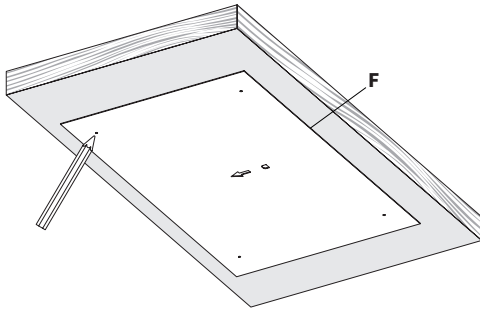

Make sure the arrow on the Template points towards the end that will have your TV.

Use the infographic below to drill mounting holes at marked locations.

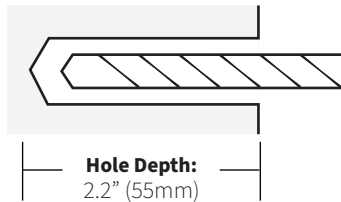
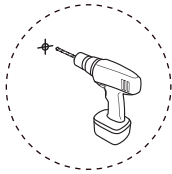

**Drill Bit:**  
3/16" (4.5mm)

**Hole Depth:**  
2.2" (55mm)

Using a socket wrench, insert ST6.3x55mm Screws (**W-A**) into the mounting holes that align with the **Keyhole Slots** of the Mount Extensions (**E**), leaving a 3mm gap from the ceiling.

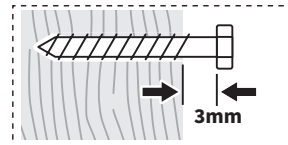
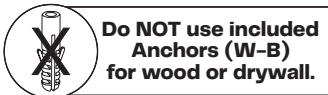
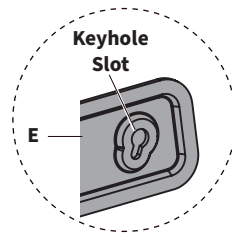
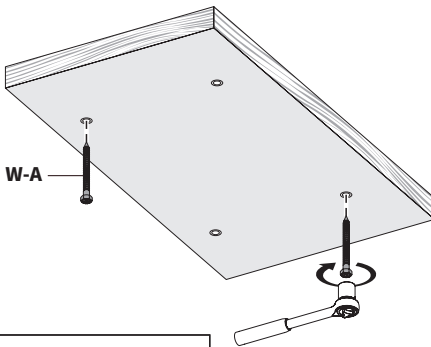

**NOTE**

**Near-to-Wall Installation**

If you are installing the Mount Assembly near a wall, make sure to leave enough room for the TV to fully swivel 90° left to right (180° total rotation) in both the up and down position.

## STEP 4

Raise the Mount Assembly so the ST6.3x55mm Screws (**W-A**) fit through the **Keyhole Slots** of the Mount Extensions (**E**). Turn Mount Assembly until supported by Screws.

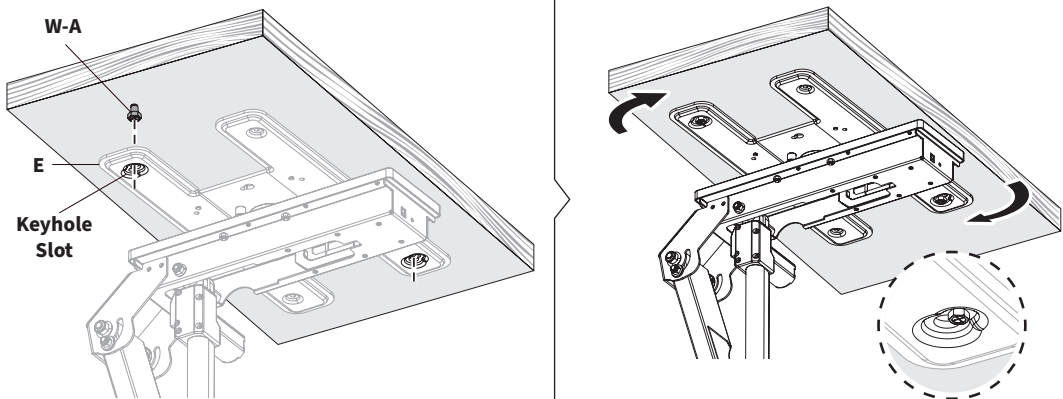

Secure Mount Assembly using the remaining ST6.3x55mm Screws (**W-A**) and M6 Washers (**W-C**). Tighten all Screws with a socket wrench.

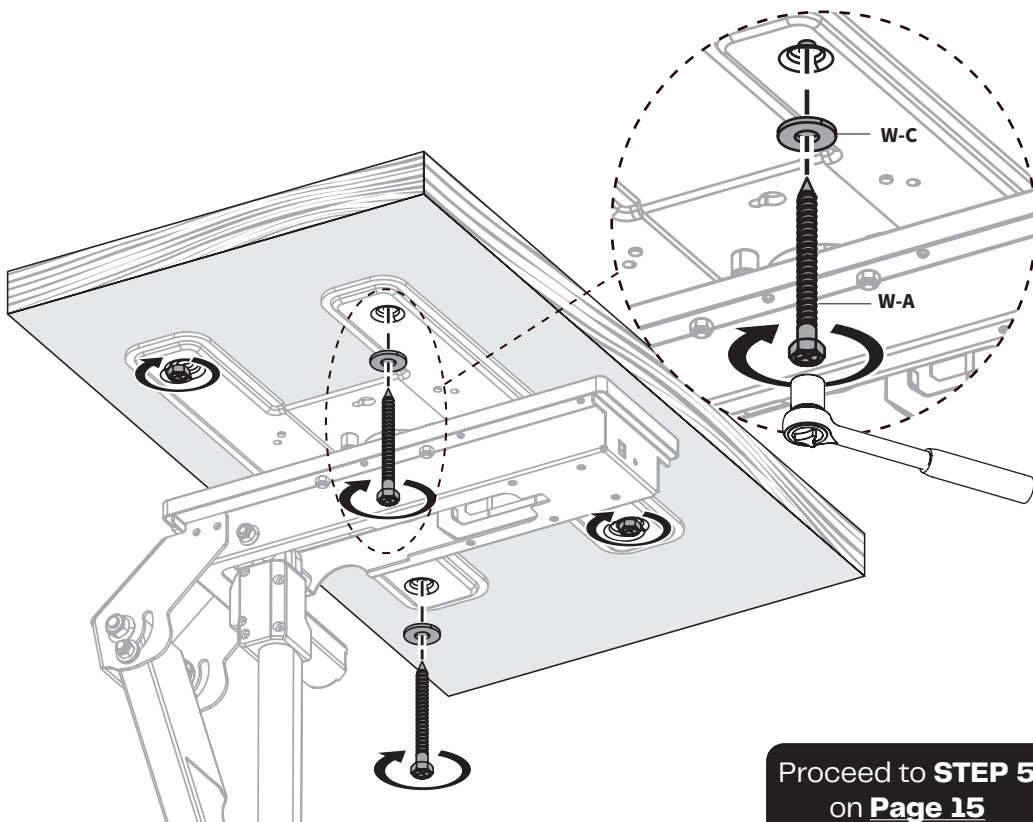

Proceed to **STEP 5**  
on **Page 15**

## - Option 3 - Concrete Mounting

### STEP 3

Position Template **(F)** in desired location and mark mounting holes.

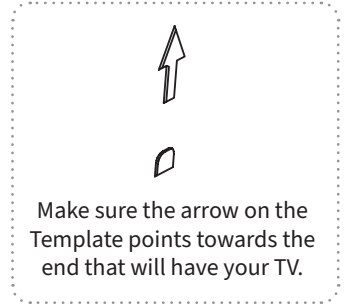
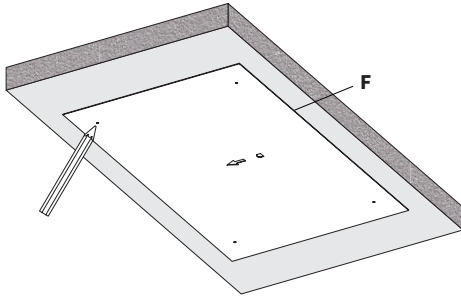

Use the infographic below to drill mounting holes at marked locations.

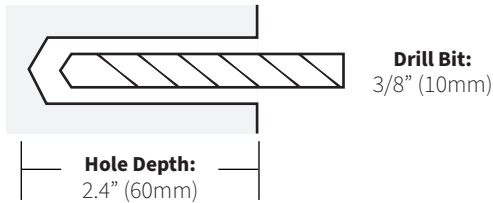

Press Concrete Anchors **(W-B)** into mounting holes. Using a socket wrench, insert ST6.3x55mm Screws **(W-A)** into the mounting holes that align with the **Keyhole Slots** of the Mount Extensions **(E)**, leaving a 3mm gap from the ceiling.

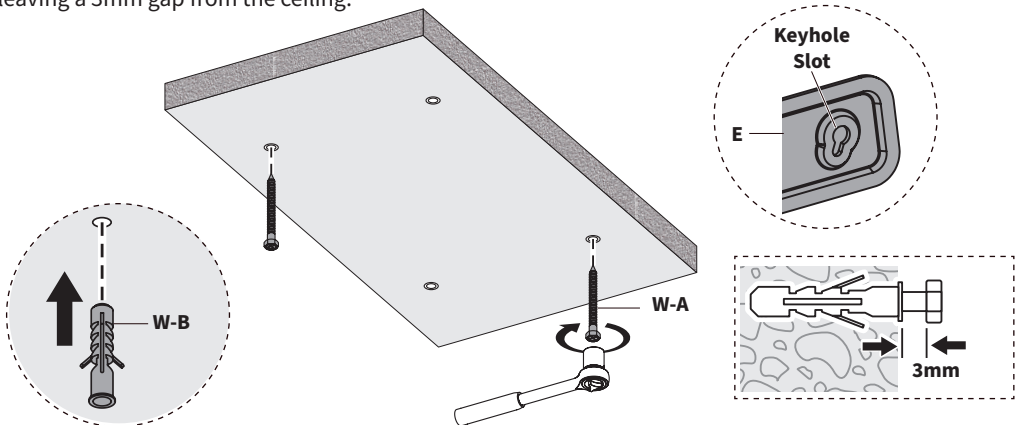

#### NOTE

#### Near-to-Wall Installation

If you are installing the Mount Assembly near a wall, make sure to leave enough room for the TV to fully swivel 90° left to right (180° total rotation) in both the up and down position.

## STEP 4

Raise the Mount Assembly so the ST6.3x55mm Screws (**W-A**) fit through the **Keyhole Slots** of the Mount Extensions (**E**). Turn Mount Assembly until supported by Screws.

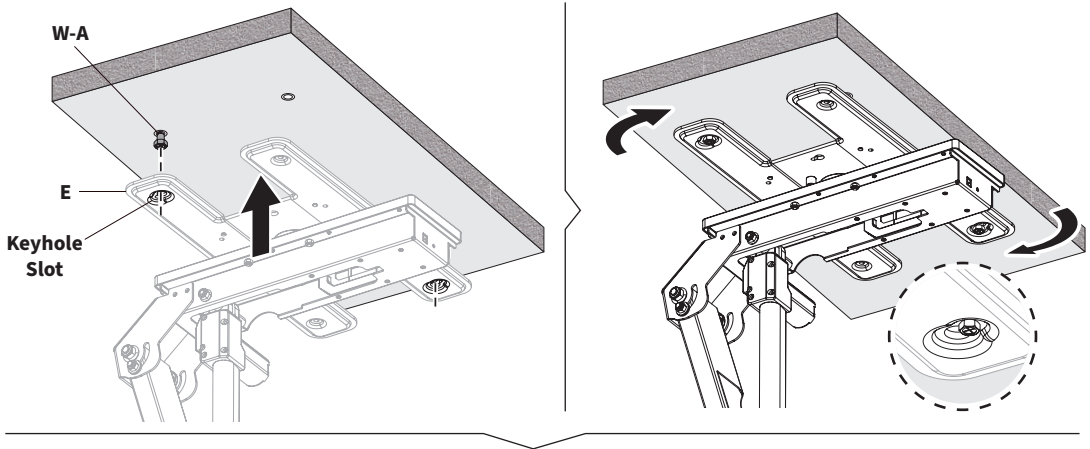

Secure Mount Assembly using the remaining ST6.3x55mm Screws (**W-A**) and M6 Washers (**W-C**). Tighten all Screws with a socket wrench.

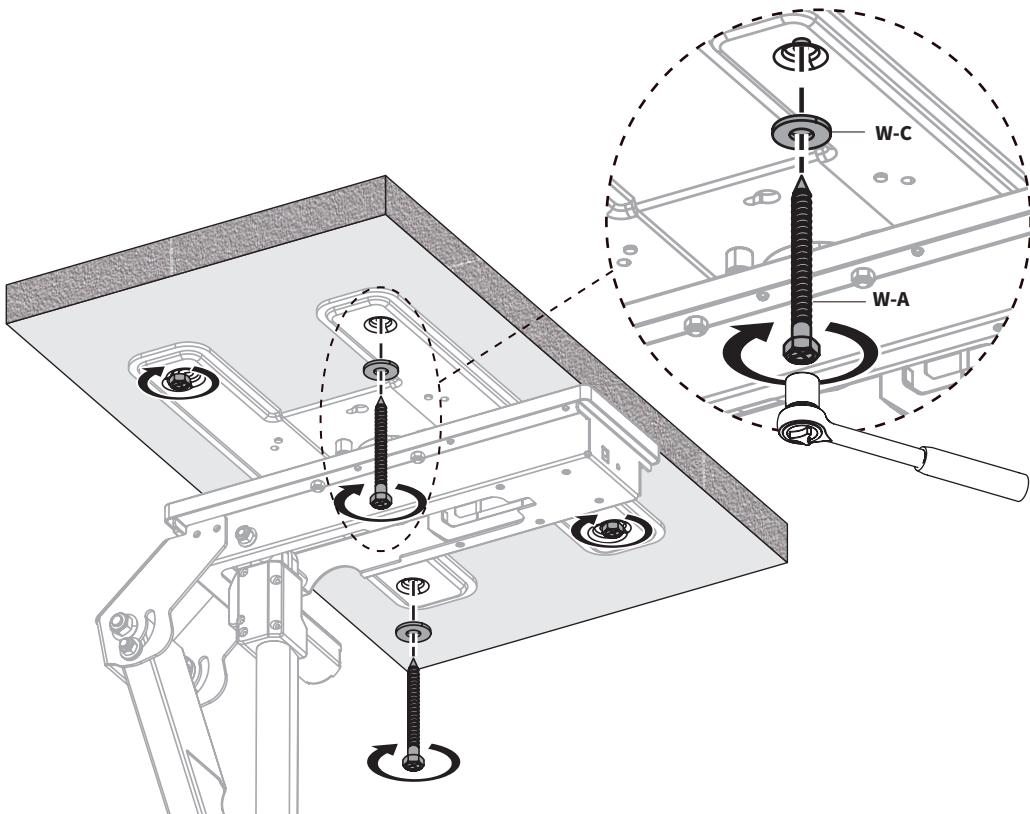

## STEP 5

Attach Bracket Rails (**B**) to Center Plate (**D**) using M6x25mm Screws (**S-D**), Large M6 Washers (**S-E**), M6 Nuts (**S-F**), a Phillips screwdriver, and a wrench.

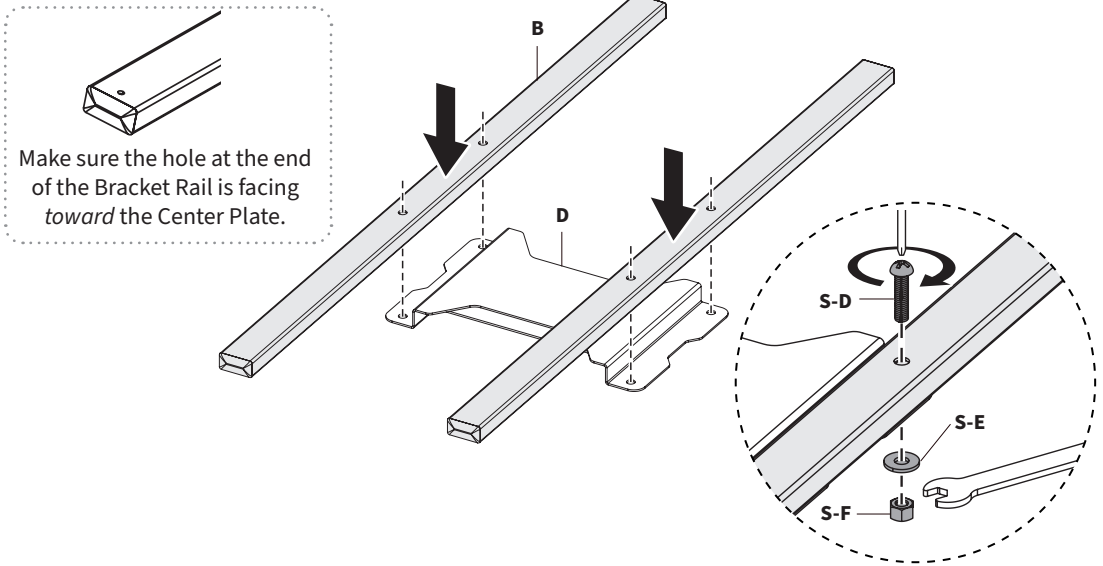

Loosen the top two preinstalled Screws (**D1**) of the Center Plate (**D**) using a Phillips screwdriver, leaving a gap between the head of the Screw and the Center Plate. Remove the bottom two preinstalled Screws (**D2**) at the other end of the Center Plate.

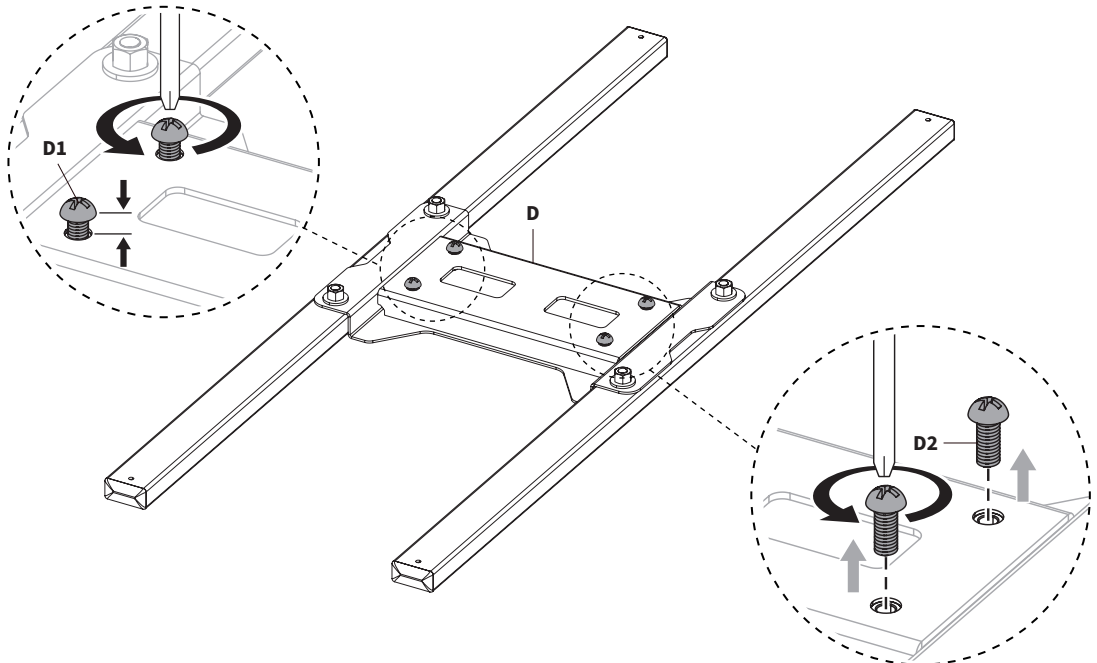

## STEP 6

Slide VESA Brackets (C) onto Bracket Rails (B).

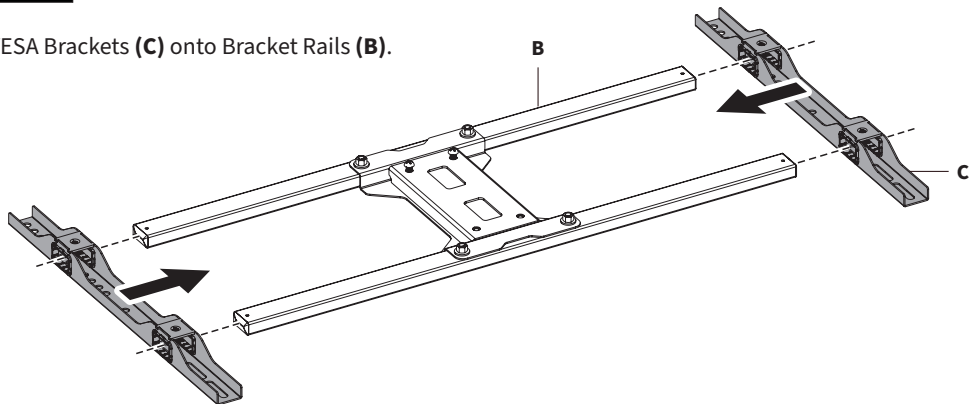

Attach M4x8mm Screws (S-A) to Bracket Rails (B) using 3mm Allen Wrench (T-A).

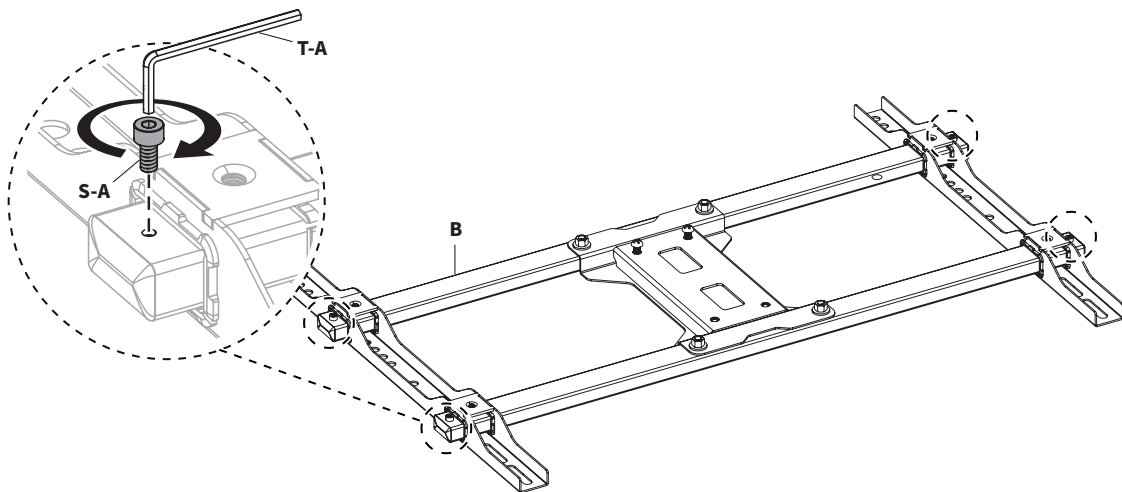

## STEP 7

Slide VESA Brackets (C) to align to the holes on the back of your TV. Make sure the Center Plate (D) is centered between the Brackets.

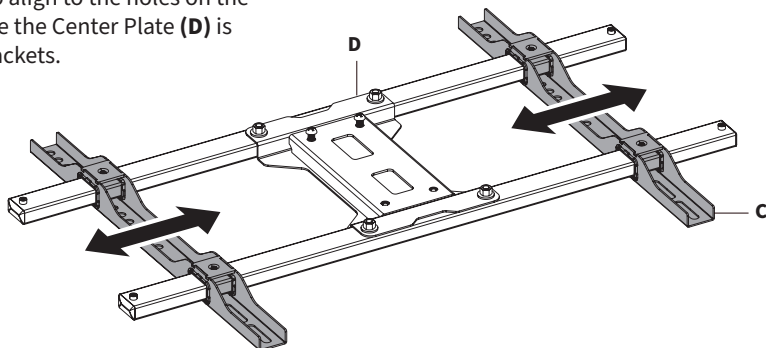

## STEP 7 - Cont'd

Attach VESA Assembly to TV using appropriate Mounting Screws (**M-A through M-D**), M8 Washers (**M-E**), and Spacers (**M-F, M-G**).

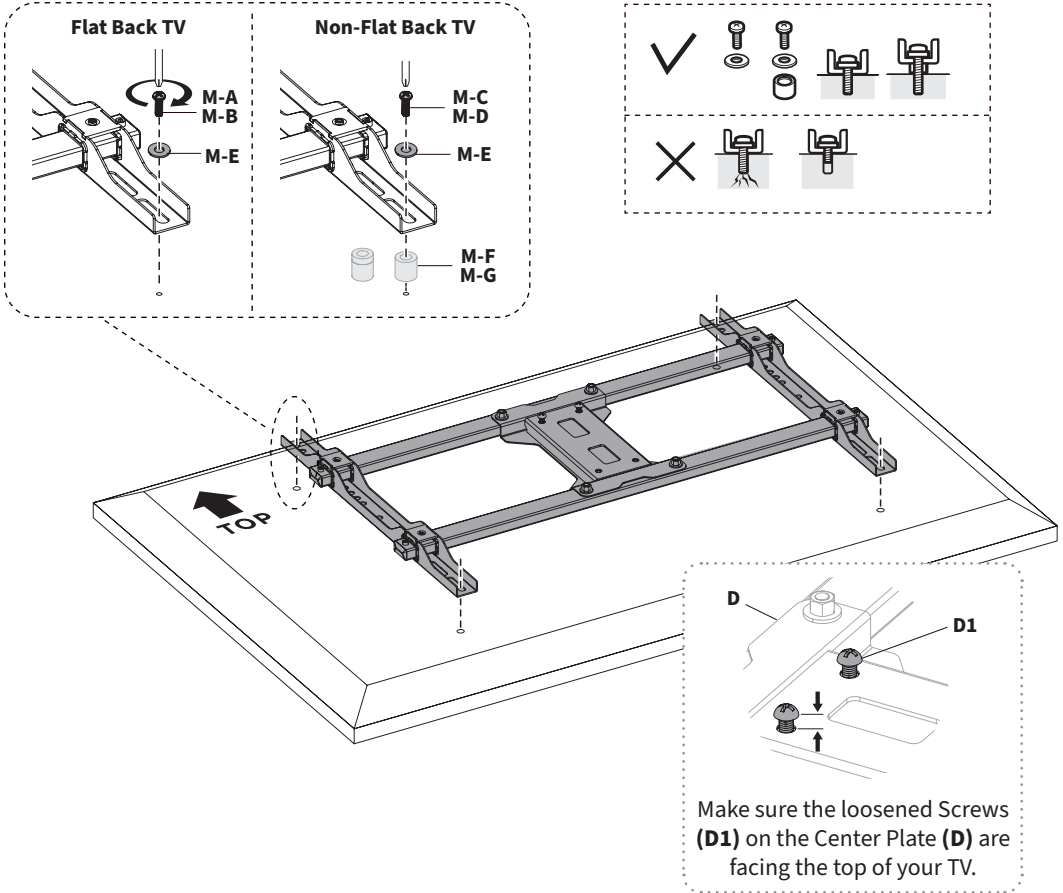

Insert Set Screws (**S-B**) in VESA Brackets (**C**) with 3mm Allen Wrench (**T-A**) to lock them in place.

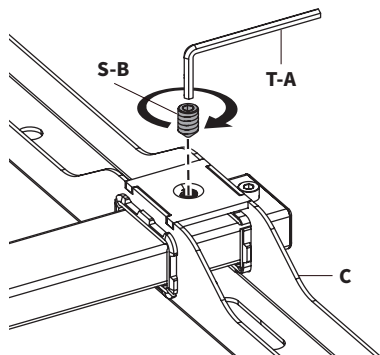

## STEP 8

Place the TV Assembly on the Mount (**A**) by lining up the loosened top Screws and inserting into **Mounting Slots** at desired height.

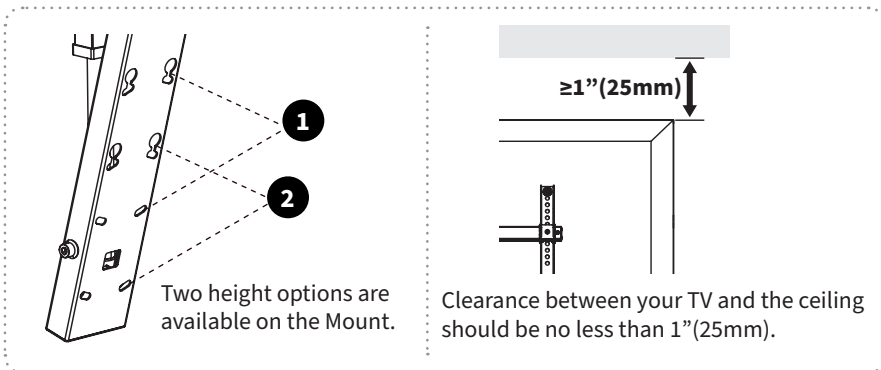
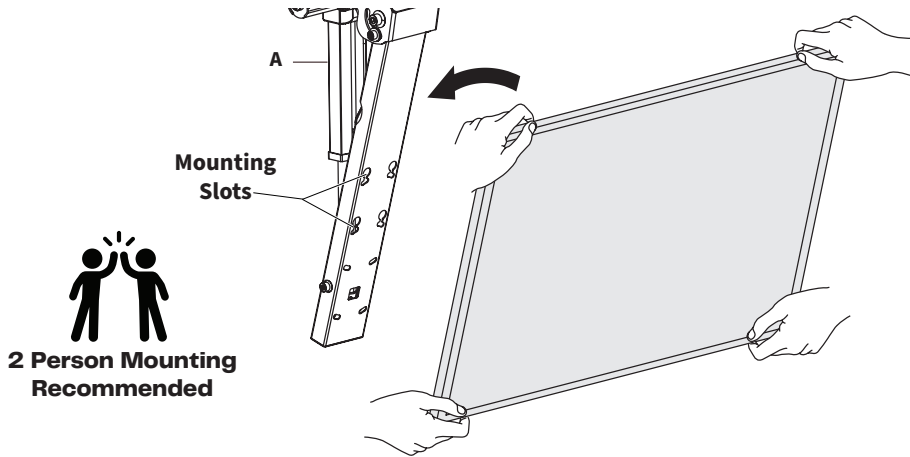

Tighten the loosened top Screws (**D1**) and reinsert previously removed bottom Screws (**D2**).

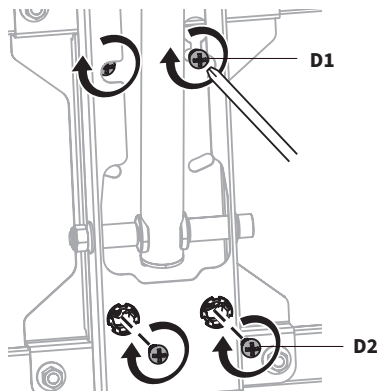

## STEP 9

Remove the adhesive backing from the Cable Clips (**J**) and place them onto the Mount (**A**) where desired. Run the TV cable along the Mount.

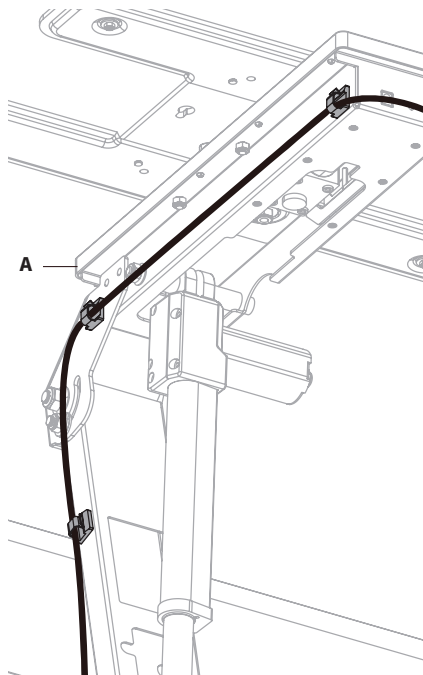
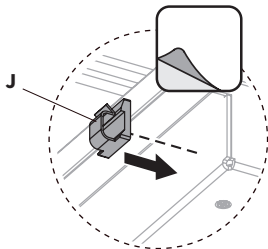

## STEP 10

1. Plug Power Adapter (**I**) into the back of Mount (**A**).
2. Plug Power Adapter into a power source.

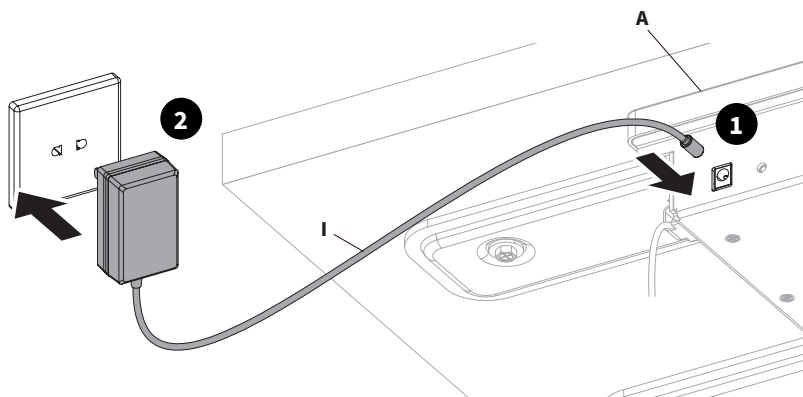

Be sure to plug the AC Adapter (**I**) into a power outlet AFTER connecting it to the Mount. Connecting the Adapter in the wrong order may cause a large spark.

## **Assembly Complete**

*TV Adjustments on next page*

## Adjustments

Adjust your TV as desired.

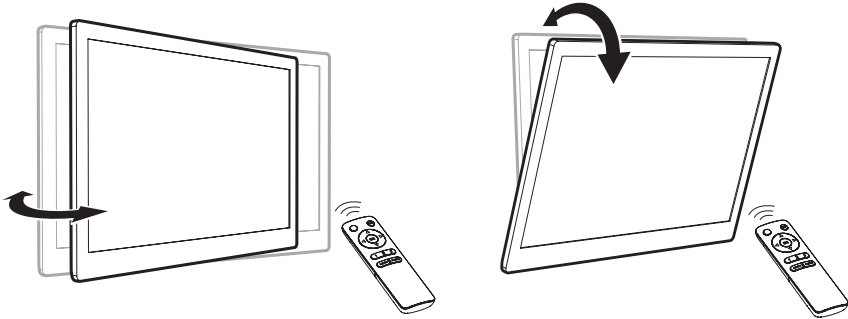

Adjust screws with a Phillips screwdriver as shown to level the display.

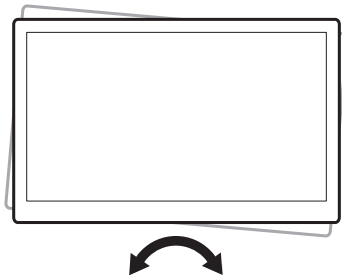
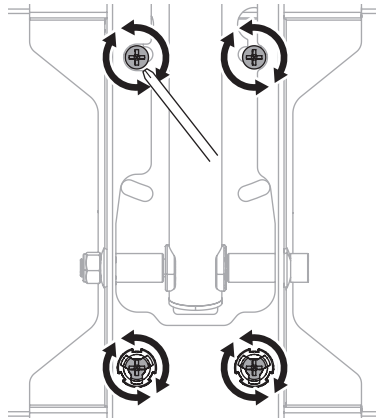

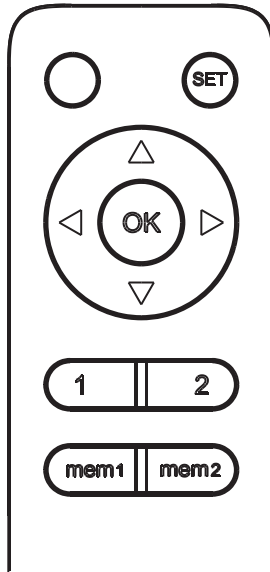

---

# Remote

User Guide

---

# Remote Control Manual

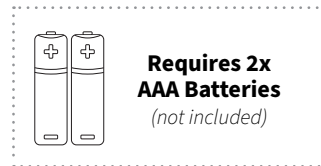
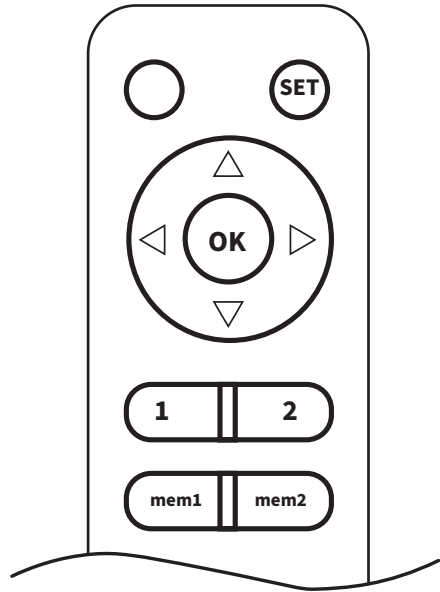
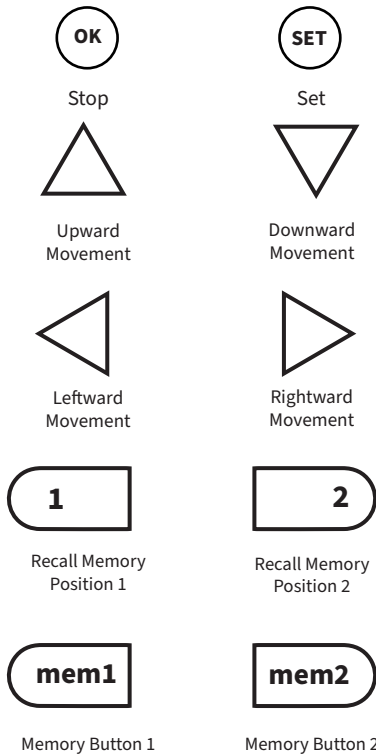

## First Time Use

1. Install two AAA batteries (*not included*) in the Remote.
2. Plug the mount in. The mount will beep once, and will be ready for operation.

### Up/Down Movement

Press the button to move the TV upward toward the ceiling. Press the button to stop the motion.

Press the button to move the TV downwards toward the lowest position (75° angle). Press the button to stop the motion.

### Left/Right Side Movement

Press the button to move the TV left by 90°. Press the button to stop movement.

Press the button to move the TV right by 90°. Press the button to stop movement.

### Return to Middle Swivel Position

Press the button when the mount is not in motion to return the mount to middle swivel position.

### Save & Recall Memory Settings

To save a certain location to memory, press and hold the **mem1** or **mem2** button for 1 second. The mount will beep, indicating the position has been saved to memory.

To recall memory locations, press **1** or **2** and the TV mount will automatically adjust to saved memory location of the corresponding memory button.

---

### Reset

If the TV ceiling mount operates abnormally, it may be necessary to perform a reset of the mount. To reset the TV ceiling mount, unplug the mount from power for 10 seconds and plug back in. Hold the OK button for 6 seconds; the mount will go up and down to the lowest position and then it will turn left and right. When the process has finished, it will return to the middle default position. A long beep will indicate that the reset was a success.

---

### Pairing the Remote

**Step 1:** With the Mount powered on, quick press the small button on the control box with a thin tool as shown. The unit will beep, indicating readiness for pairing.

**Step 2:** Quick press the **SET** button on the Remote, and the control box will repeatedly beep for approximately 10 seconds indicating that the Remote is being paired. When the beeping has stopped, the mount will be ready for operation.

**Note:** The **SET** button must be pressed within 10 seconds of the Mount's beep.

**Note:** The Mount can be paired with up to 20 Remotes.

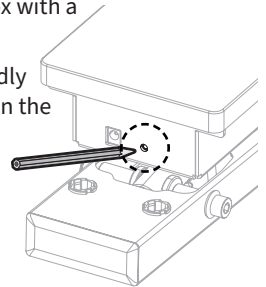

### Unpairing the Remote

To unpair the remote and clear the data of all paired remotes and phone apps, use a thin tool (such as a paperclip) to long press the small button on the back of the control box. The mount will emit one beep when button is first pressed; continue to hold for 5 seconds; the mount will beep again signaling that the remote has been unpaired and pairing data has been removed.

To disconnect the app, quick press the **mem2** button 5 times.

[ THIS PAGE HAS BEEN INTENTIONALLY LEFT BLANK ]

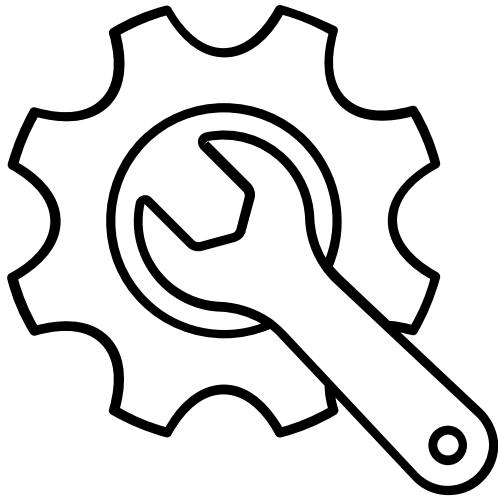

---

# Troubleshooting

---

## Troubleshooting

Find solutions to possible issues in the chart below.

Problem	Solution
The Mount is Making a Buzzing Alarm Sound	This signals an error in Mount position. Reset the system by following the “Reset” instructions on page 23.
Remote Battery Drains Too Quickly	Make sure that your Remote had fresh batteries. If problem persists with fresh batteries, please contact us at 309-278-5303 or <a href="mailto:help@vivo-us.com">help@vivo-us.com</a> to replace the Remote.
Remote Buttons Don’t Work	Check to make sure the Remote has working batteries. If the problem persists, try to re-pair the Remote following the “Pairing the Remote” instructions on page 23. If the problem persists, please contact us at 309-278-5303 or <a href="mailto:help@vivo-us.com">help@vivo-us.com</a> to replace the Remote. If the problem persists with the replacement Remote, contact us to replace the product.
Remote Has Limited Range	If your Remote has a limited range and won’t function unless it is within 10 feet (3 meters) of the Mount, replace the batteries. If the problem persists, please contact us at 309-278-5303 or <a href="mailto:help@vivo-us.com">help@vivo-us.com</a> to replace the Remote.
Mount Has Limited Tilt Range	If your TV can’t reach the angles of 0° or 75°, reset the system following the instructions of the “Reset” section on page 23. If the problem persists, please contact us at 309-278-5303 or <a href="mailto:help@vivo-us.com">help@vivo-us.com</a> to replace the Remote.
Mount Won’t Operate	Check to see if the Power Adapter is properly connected to the Mount. If so, plug the Power Adapter into a power source. If there is no buzzer tone or red light power indication, please contact us at 309-278-5303 or <a href="mailto:help@vivo-us.com">help@vivo-us.com</a> to replace the Power Adapter. If the problem persists with the replacement Power Adapter, contact us to replace the product.
Mount Makes an Abnormal Noise	Please contact us at 309-278-5303 or <a href="mailto:help@vivo-us.com">help@vivo-us.com</a> to replace the product.

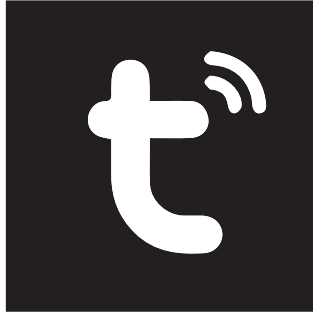

---

# TU YA<sup>®</sup> Smart | Mobile App

Setup & Use

---

DOWNLOAD **TU YA SMART** APP IN YOUR APP STORE

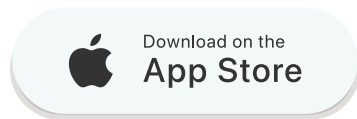

# Tuya App | Basic Functions

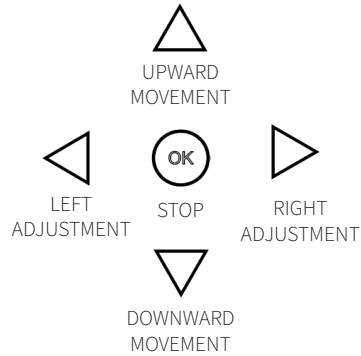
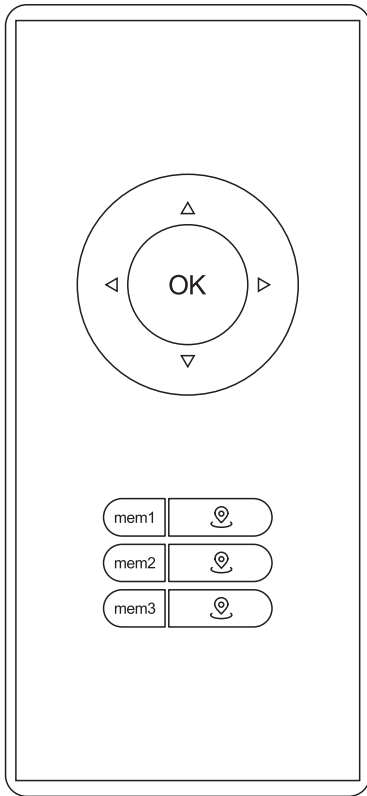

MEMORY SET 1      MEMORY RECALL 1



MEMORY SET 2      MEMORY RECALL 2



MEMORY SET 3      MEMORY RECALL 3

## Standard Operation

### Using Arrow Keys

**UP:** Tap the button to move the TV upward toward the ceiling. Press the button to stop the motion.

**DOWN:** Tap the button to move the TV downwards toward the lowest position. Press the button to stop the motion.

**LEFT:** Tap the button to move the TV left by 90°. Press the button to stop the motion.

**RIGHT:** Tap the button to move the TV right by 90°. Press the button to stop the motion.

**OK:** Tap if the mount is not in motion. This will return the mount to the middle swivel position.

### Saving & Using Memory Settings

Use the arrow buttons to set your desired TV position. Then select one of the 3 Memory Buttons to save the position as a preset. To return to a preset, simply select the icon next to the desired Memory setting. For example, to return to Memory Setting 2, select the icon next to .

*Please note: Tuya Smart app has three memory functions, while the standard remote has only two.*

## Setting Up & Creating an Account

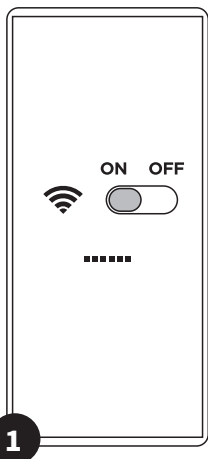

### TURN ON WIFI

Before you begin, ensure that Wifi is enabled on your phone.



### CREATE ACCOUNT

Open Tuya Smart App and select **Sign-Up** from start screen. Follow on-screen prompts.

## Pairing to Mount

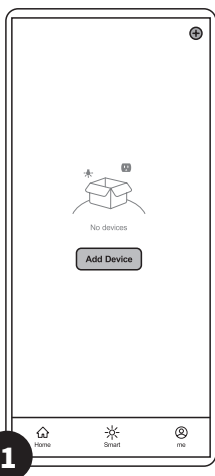

### ADD DEVICE

Tap **Add Device** or the + icon in upper right corner to begin device pairing.

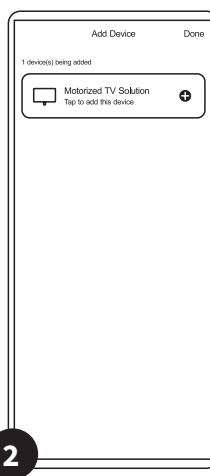

### MOTORIZED TV SOLUTION

Tap *Motorized TV Solution* in the Auto Scan page and go to "Next".

*Only one Tuya Smart account can be synced to Mount at one time.*

*If Mount does not appear, refer to "Unpairing Mount from App (option 2)" on Page 31.*

## Pairing to Mount – Cont'd

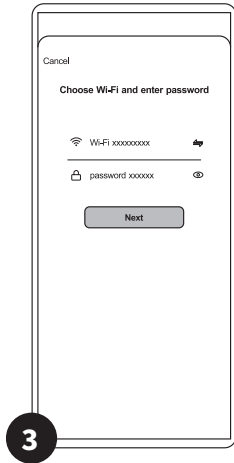

### CONNECT TO WIFI

Select your Wifi from available list and enter password to enable mount access. Tap “Next”.

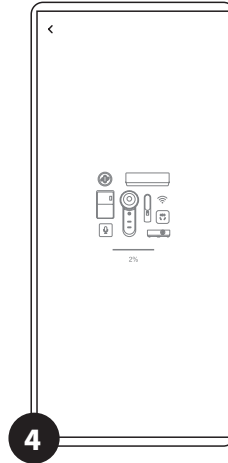

### CONNECTION SCREEN

If Wifi connection was successful, connection to your TV mount will begin. Please allow 10-60 seconds for connection process to be completed.

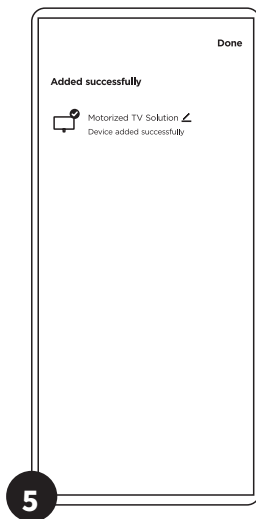

### DEVICE ADDED SUCCESSFULLY

Once connection is made, a confirmation screen will show. Click “Done” to enter the Remote Dashboard.

**Note:** From here, you can tap the ↙ icon to change the name of your TV mount, if desired.

Turn to **Page 28** for operation instructions.

## Unpairing Mount from App

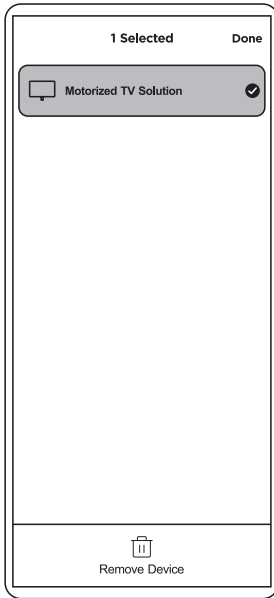

From the Home screen, locate your TV mount, then long press to open device options.

**Option 1:** Select **Remove Device** at the bottom of the screen to unpair the mount from your app.

**Option 2:** Quick press the  button 5 times to disconnect from the app.

## Reset Mount with App

### RESET MODE

If the TV ceiling mount operates abnormally, it may be necessary to perform a reset of the mount. To reset the TV ceiling mount, unplug the mount from power for 10 seconds and plug back in. Hold the OK button for 6 seconds; the mount will go up and down to the lowest position and then it will turn left and right. When the process has finished, it will return to the middle default position.

# Syncing Other Mobile Devices

To allow other mobile devices to control the TV mount, you will need to first create **Home** in the app and then invite other users to your Home.

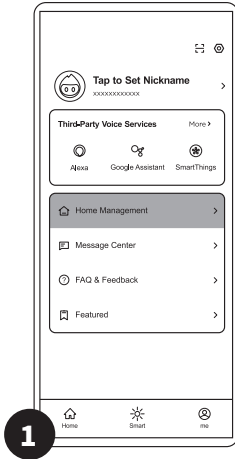

## HOME MANAGEMENT

Select the **ME** (👤) icon to navigate to the Home screen. Tap **Home Management**.

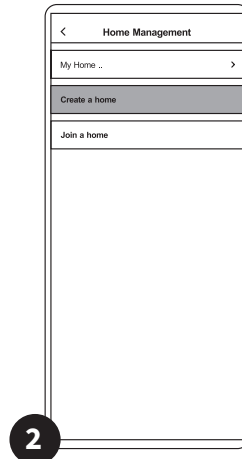

## CREATE A HOME

Tap **Create A Home** to proceed.

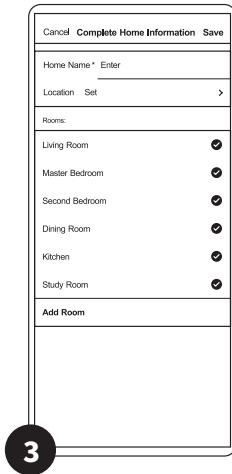

## SET UP HOME

Complete required information to set up a HOME and tap **SAVE** to continue.

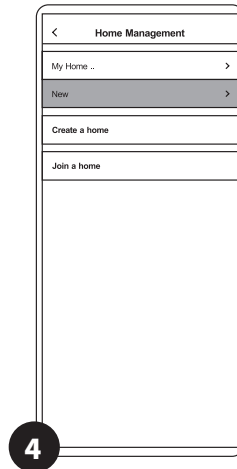

## HOME

Return to Home Management screen and tap the **Home** you just created.

Please note: The **Home Name** has a 25 character limit.

## Syncing Other Mobile Devices – Cont'd

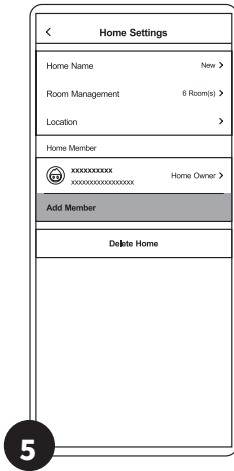

### INVITE OTHER MEMBERS

Tap **Add Member** and choose an invitation method. New users will receive link to download Tuya Smart app with an invitation code to join your **Home**. Users will need to download app and create an account to proceed.

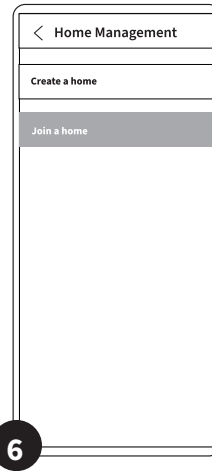

### JOINING A HOME

Once app is installed and registered, new user will tap the **ME** (👤) icon on the bottom right. From that screen, tap **Home Management** and then **Join a Home**.

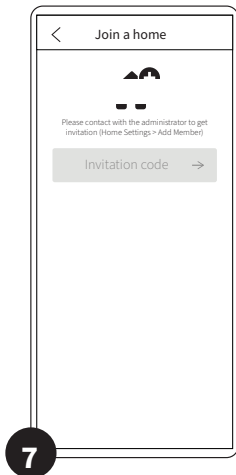

### ENTER INVITATION CODE

Enter the code that was received with the invitation and tap **+** to continue.

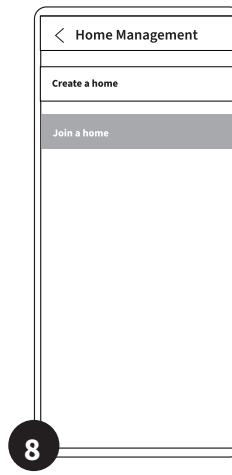



### HOME ADDED

The new **Home** will now show under **Home Management**.

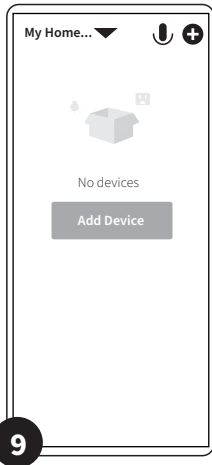
## Syncing Other Mobile Devices – Cont'd



### CHANGING HOME SCREEN

Select the  icon to navigate to the Home screen. Tap the  next to *My Home...* at the top of the screen.

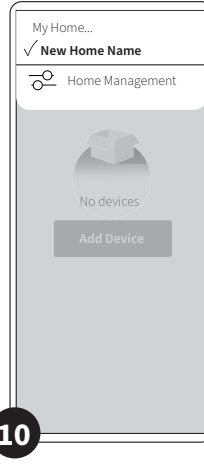

### SELECT NEW HOME

From dropdown, select the name of the new home you were invited to.

Please note: You may be asked to allow Wifi permissions.



### DEVICE ADDED

New home screen will now show mount. Click on mount name to activate controls.



---

# Voice Control

Amazon Alexa<sup>®</sup> & Google Home<sup>®</sup>  
Setup & Use

---

# Setting Up Amazon Alexa

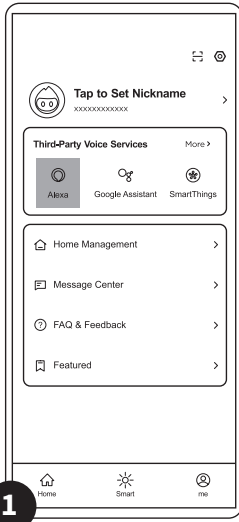

## DOWNLOAD AMAZON ALEXA APP

Download the Amazon Alexa app from the App Store or Google Play. Once installed, return to the Tuya app and tap on "me" in the bottom right corner, and tap "Alexa".

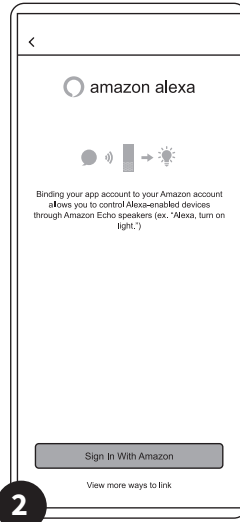

## SIGN IN

Click "Sign in with Amazon".

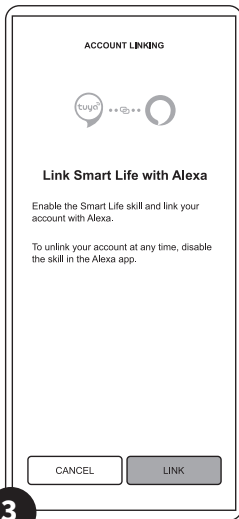

## LINK

Tap "Link" to begin the linking process.

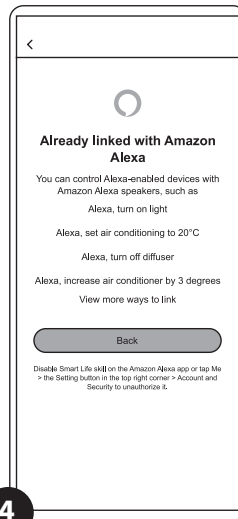

## DEVICE ADDED

Once the linking is complete, you can start controlling the TV mount via Amazon Alexa.

# Setting Up Google Home

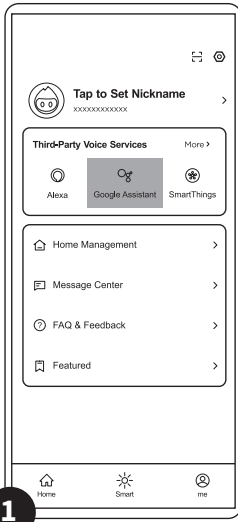

## DOWNLOAD GOOGLE HOME APP

Download the Google Home app from the App Store or Google Play. Once installed, return to the Tuya app and tap on "me" in the bottom right corner, and tap on "Google Assistant".

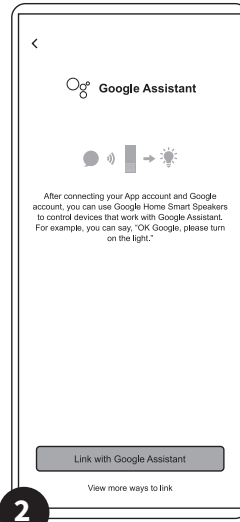

## LINK

Tap "Link with Google Assistant" to launch the Google Home app.

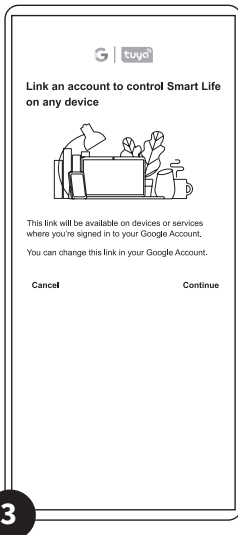

## CONTINUE

Tap "Continue" to return to the Tuya App.

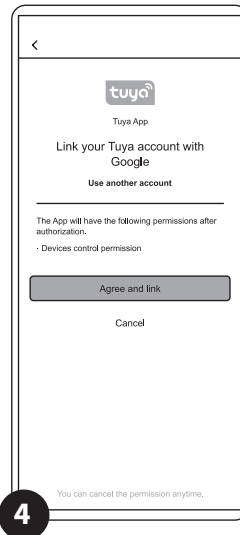

## DEVICE ADDED

Tap "Agree and link" to return to the Google Home app. The linking is complete, and you can start controlling the TV mount via Google Home.

## Voice Commands

Action	Amazon Alexa®	Google Home®
<b>Upward Movement</b>	Alexa, set <devicename> to up	OK Google, set <deviceName> to up
<b>Downward Movement</b>	Alexa, set <devicename> to down	OK Google, set <deviceName> to down
<b>Left Movement</b>	Alexa, set <devicename> to left	OK Google, set <deviceName> to left
<b>Right Movement</b>	Alexa, set <devicename> to right	OK Google, set <deviceName> to right
<b>Stop</b>	Alexa, set <devicename> to stop	OK Google, set <deviceName> to stop
<b>Save Current Position as Memory 1</b>	Alexa, set <devicename> to Memory one	OK Google, set <deviceName> to Memory one
<b>Save Current Position as Memory 2</b>	Alexa, set <devicename> to Memory two	OK Google, set <deviceName> to Memory two
<b>Save Current Position as Memory 3</b>	Alexa, set <devicename> to Memory three	OK Google, set <deviceName> to Memory three
<b>Move to Memory Position 1</b>	Alexa, set <devicename> to Position one	OK Google, set <deviceName> to Position one
<b>Move to Memory Position 2</b>	Alexa, set <devicename> to Position two	OK Google, set <deviceName> to Position two
<b>Move to Memory Position 3</b>	Alexa, set <devicename> to Position three	OK Google, set <deviceName> to Position three
<b>Move to Initial Position</b>	Alexa, set <devicename> to Home	OK Google, set <deviceName> to Home



## Better Products for a Better Workspace Experience

We are dedicated to creating high-end ergonomic solutions for the office with top of the industry support.

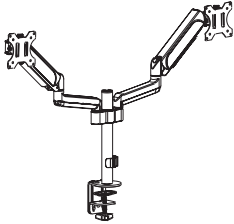

### Monitor Mounts

Mount ultrawide monitors and more with our clamp-on and wall mount solutions.

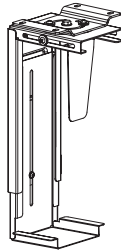

### PC Carts & Mounts

Securely store your PC in an under desk mount or cart for easy access.

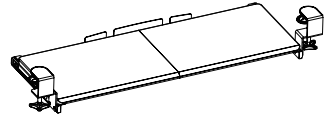

### Keyboard Trays

Clamp on & under desk keyboard tray options for all setup types.

Explore Endless Workspace Solutions  
[www.vivo-us.com](http://www.vivo-us.com)



## Need Help? **We're Here For You**

Monday-Friday from 7am-7pm CST

Saturday 8am-4pm CST



Email Us

[help@vivo-us.com](mailto:help@vivo-us.com)



Chat with Live Agent

[www.vivo-us.com](http://www.vivo-us.com)



Give Us a Call

309-278-5303 ext. 1



VIVO-us



@vivo\_us



@VIVOus



VIVO