

ASSEMBLY INSTRUCTIONS

DINING TABLE

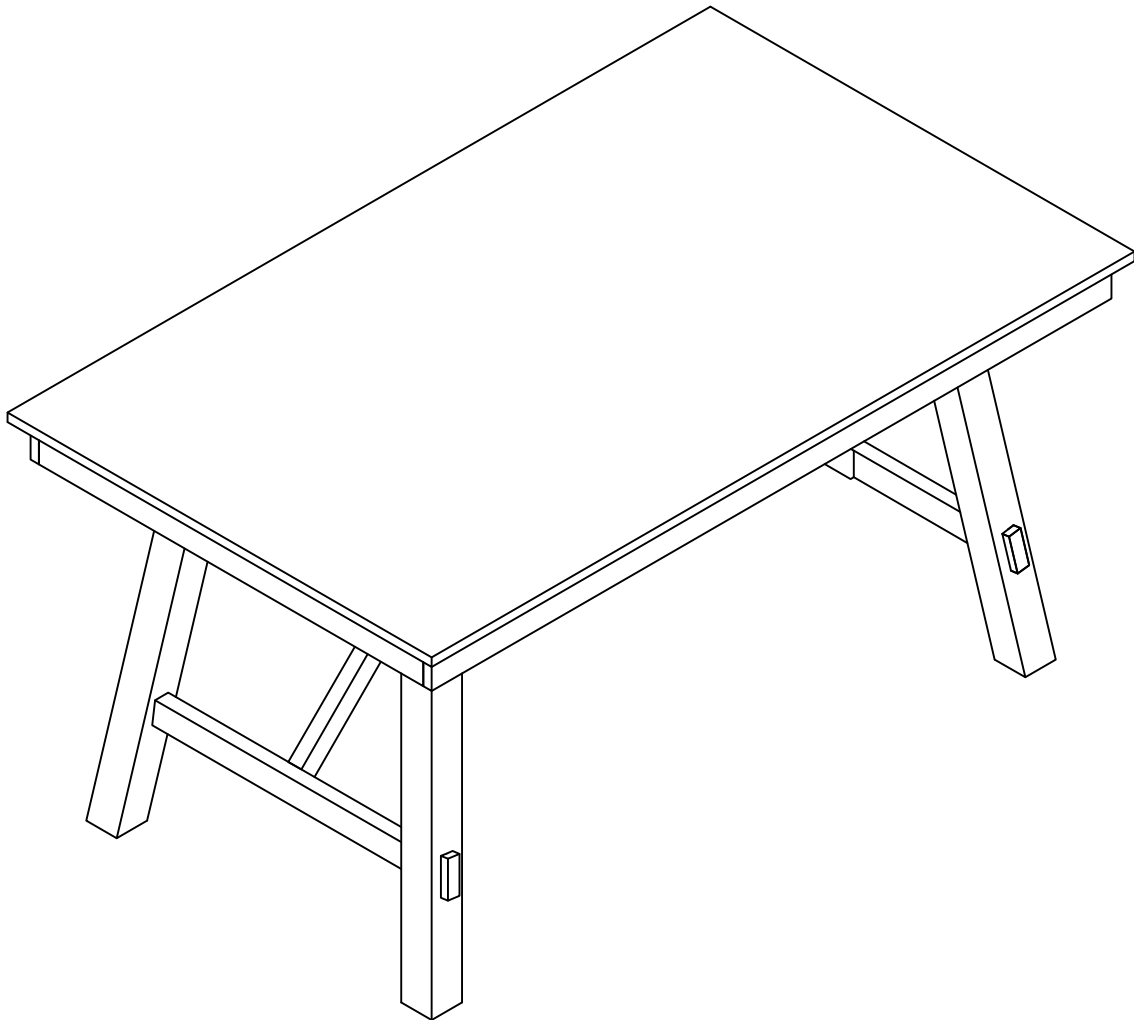



WF303489

IMPORTANT NOTE :

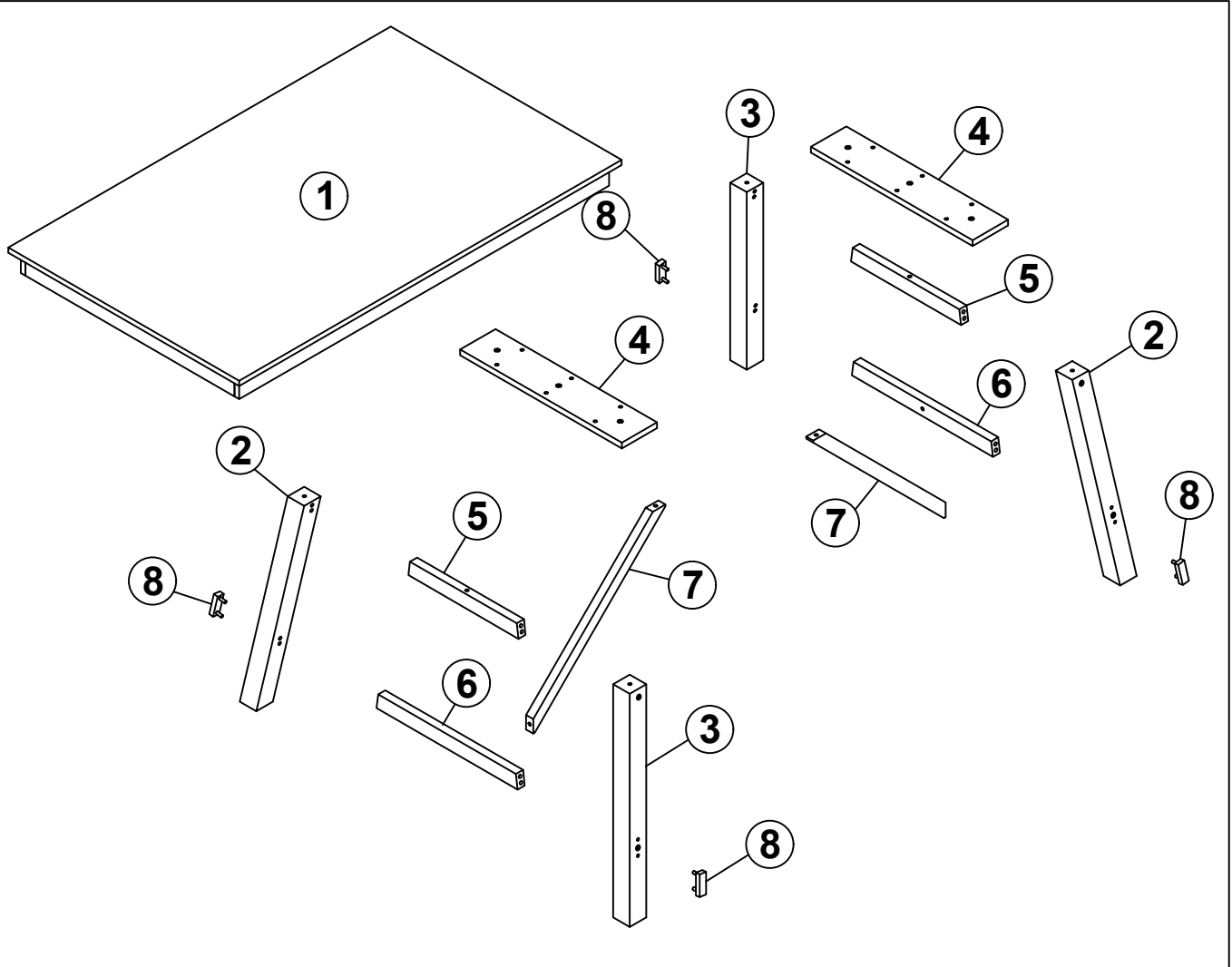
- ① PLACE ALL PARTS ON A CLEAN AND SMOOTH SURFACE SUCH AS A RUG OR CARPET TO AVOID THE PARTS FROM BEING SCRATCHED.
- ② BEFORE YOU BEGIN , KINDLY FOLLOW THE ASSEMBLY INSTRUCTIONS STEP BY STEP.
- ③ DO NOT TIGHTEN ALL SCREWS AND BOLTS UNTIL THE TABLE IS FULLY SET-UP

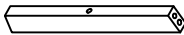
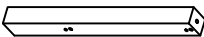
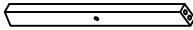
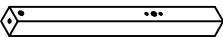
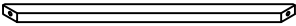

PART LIST

<p>①</p> 	<p>⑤</p> 
<p>TOP TABLE (1pc)</p>	<p>STRETCHER (2pcs)</p>
<p>②</p> 	<p>⑥</p> 
<p>LEGS TABLE (2pcs)</p>	<p>STRETCHER (2pcs)</p>
<p>③</p> 	<p>⑦</p> 
<p>LEGS TABLE (2pcs)</p>	<p>STRETCHER (2pcs)</p>
<p>④</p> 	<p>⑧</p> 
<p>CROSSBAR (2pcs)</p>	<p>WOODEN STICKS (4pcs)</p>

ASSEMBLY INSTRUCTIONS

HARDWARE LIST

A



Ø5/16" x 80mm

BOLT (8pcs)

C



Ø10" x 40mm

WOODEN PEGS (8pcs)

B



Ø5/16" x 30mm

BOLT (22pcs)

D



4mm

ALLENKEY (1pc)

Step 1

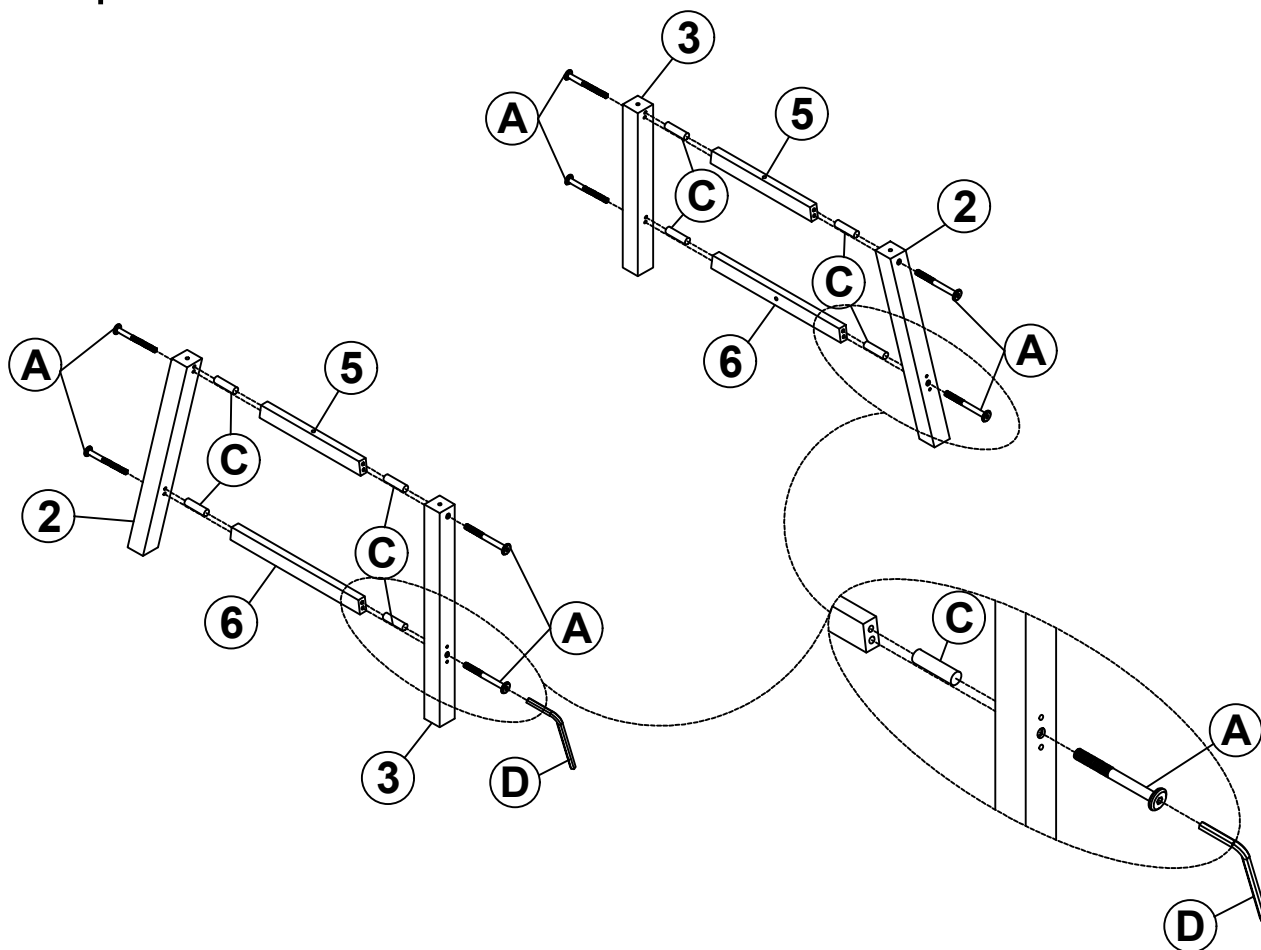

C	Ø10x40		8PCS				
D	4x58		1PC	A	5/16x80		8PCS

ASSEMBLY INSTRUCTIONS

Step 2

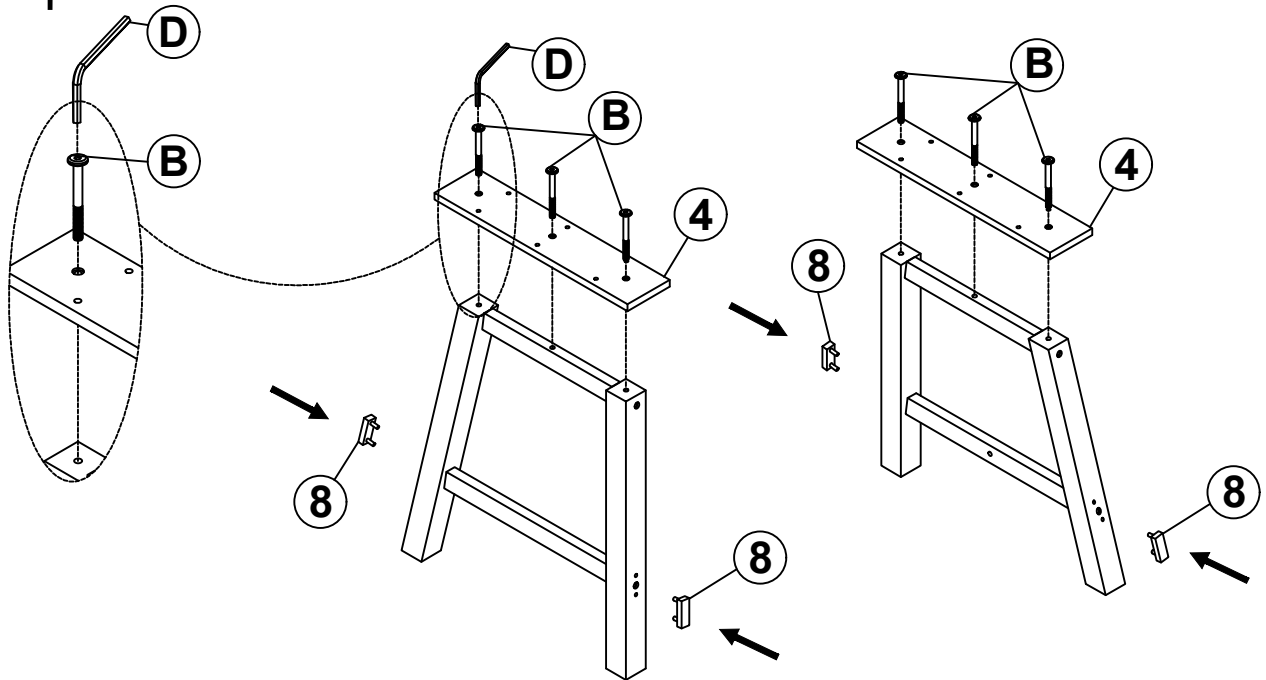

D

4x58



1PC

B

5/16x30



6PCS

Step 3

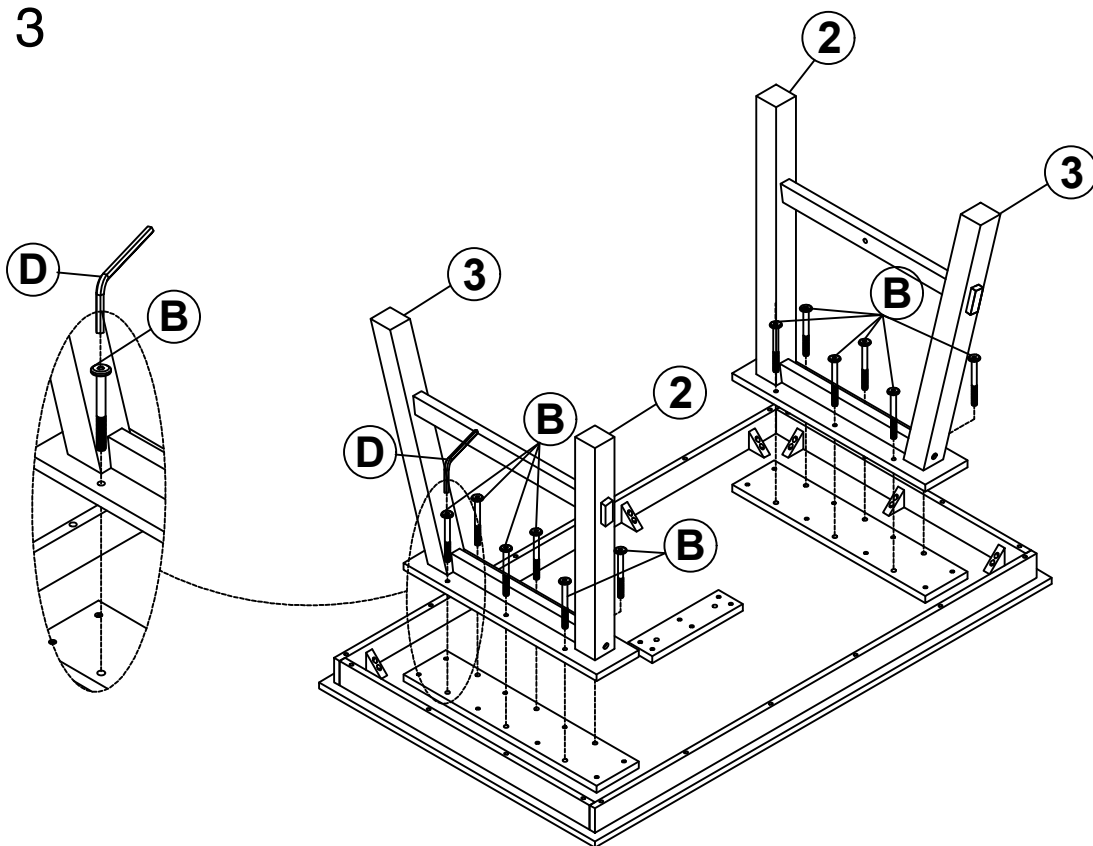

D

4x58



1PC

B

5/16x30



12PCS

ASSEMBLY INSTRUCTIONS

Step 4

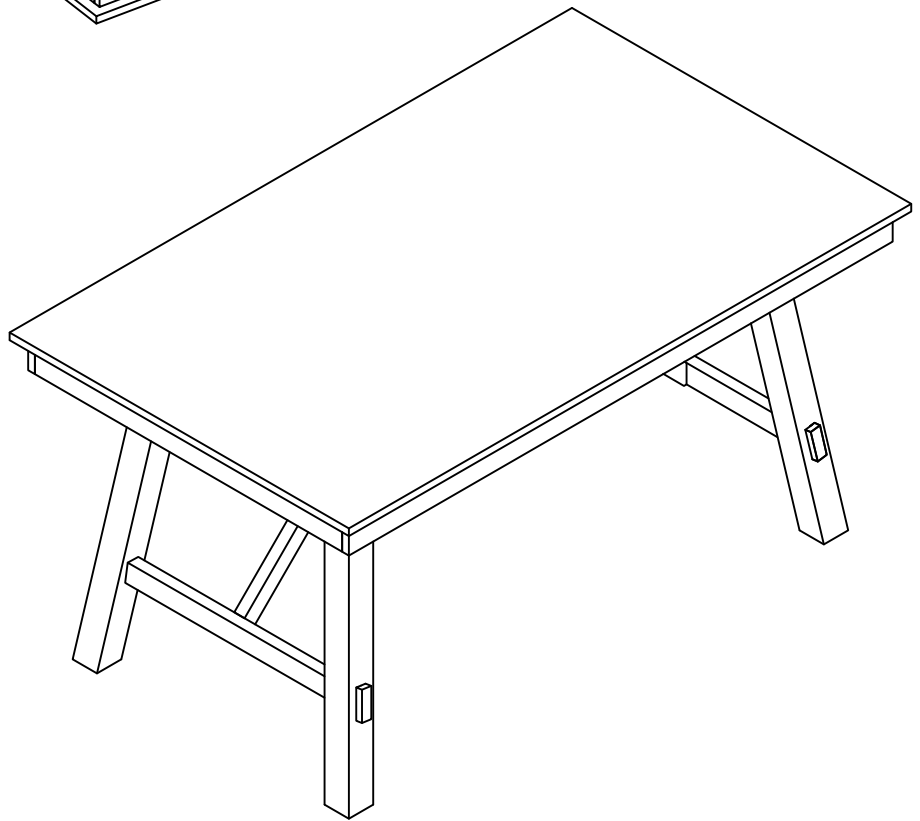
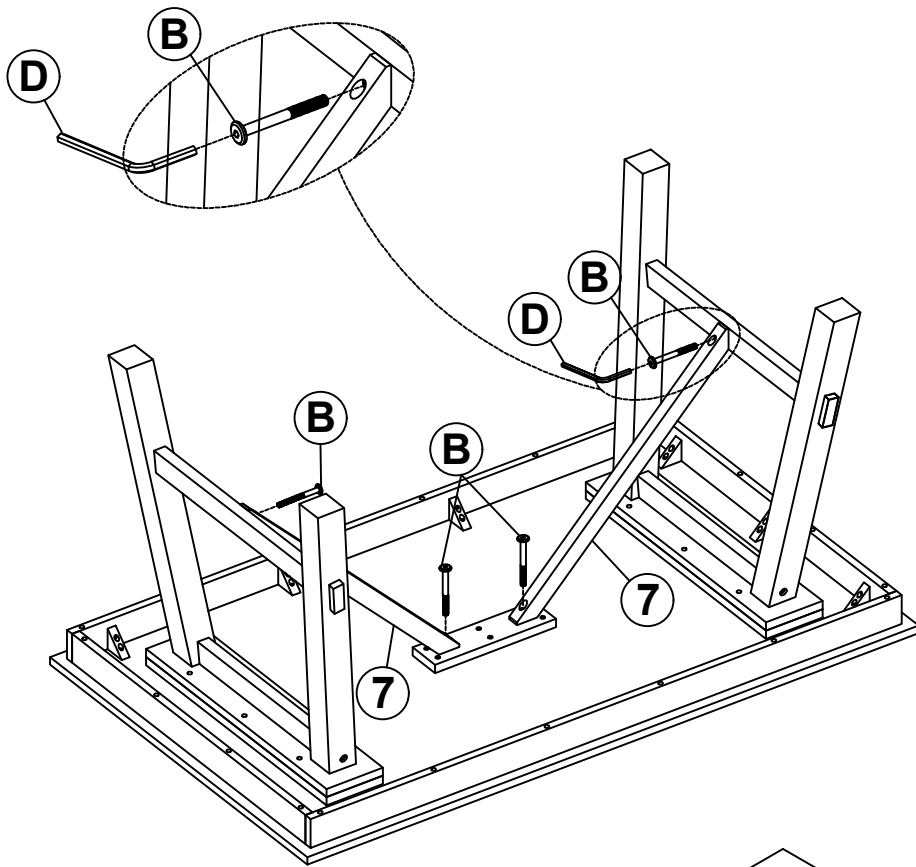

D	4x58		1PC	B	5/16x30		4PCS
----------	------	---	-----	----------	---------	---	------

ASSEMBLY INSTRUCTIONS

DINING BENCH

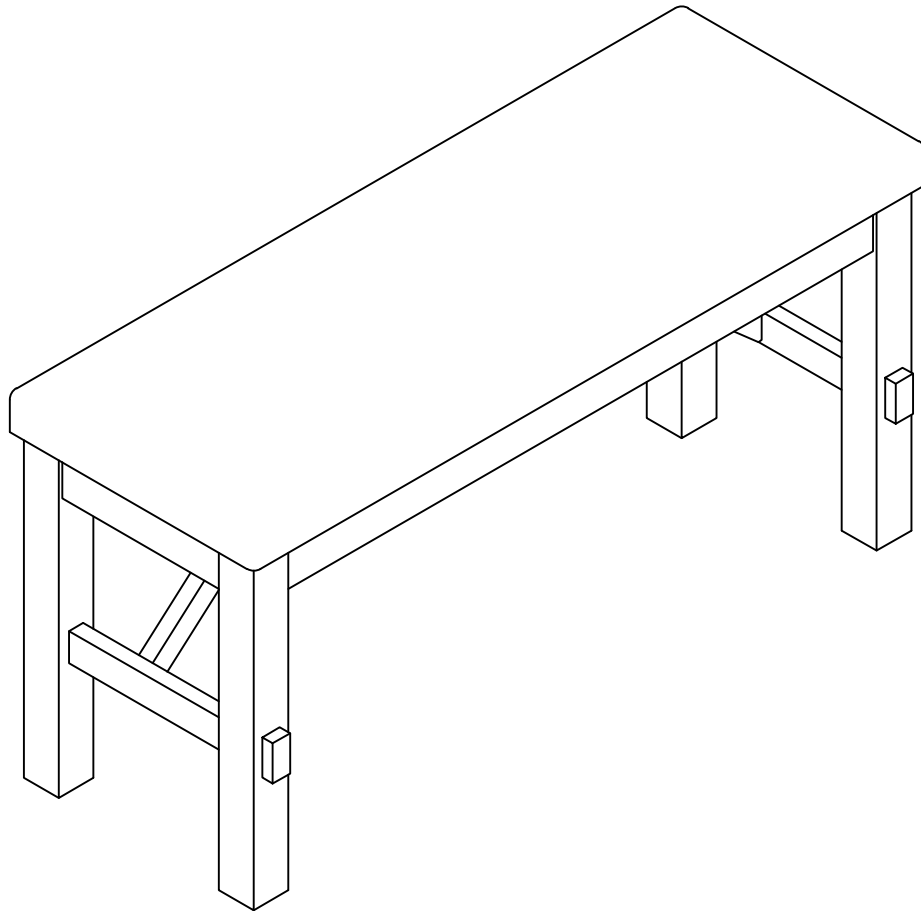







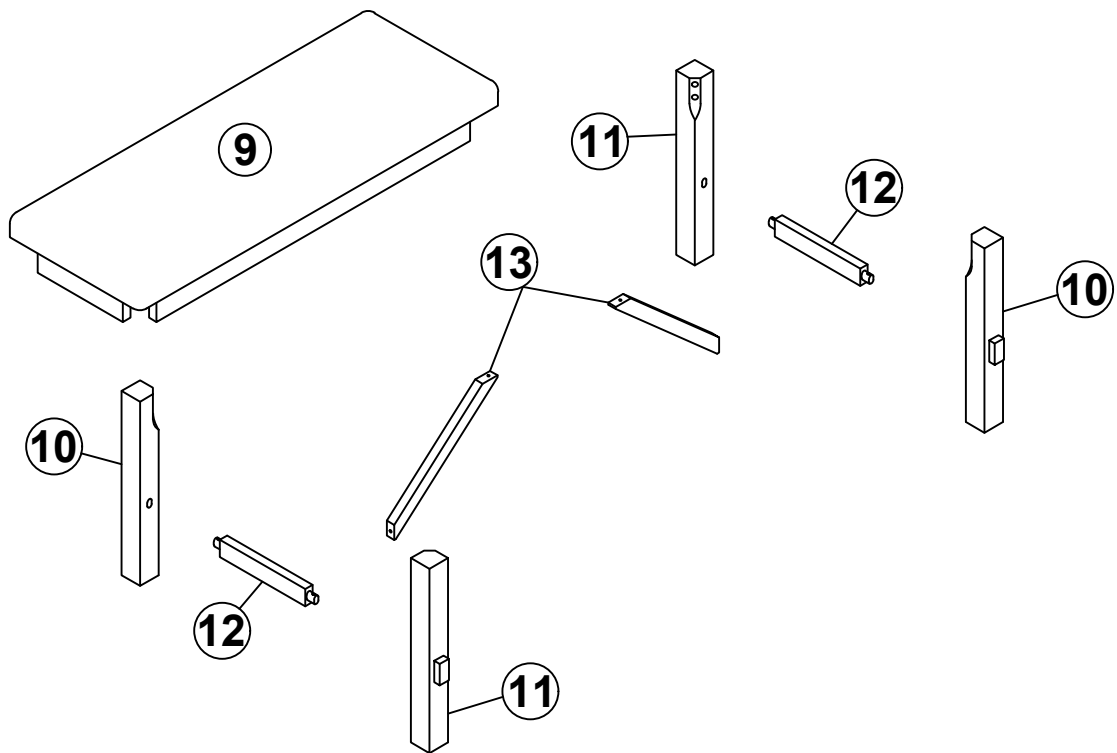

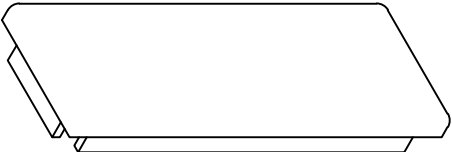

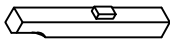
WF303490

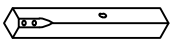
IMPORTANT NOTE :

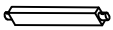
- ① PLACE ALL PARTS ON A CLEAN AND SMOOTH SURFACE SUCH AS A RUG OR CARPET TO AVOID THE PARTS FROM BEING SCRATCHED.
- ② BEFORE YOU BEGIN , KINDLY FOLLOW THE ASSEMBLY INSTRUCTIONS STEP BY STEP.
- ③ DO NOT TIGHTEN ALL SCREWS AND BOLTS UNTIL THE BENCH IS FULLY SET-UP

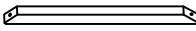

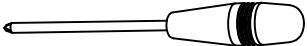

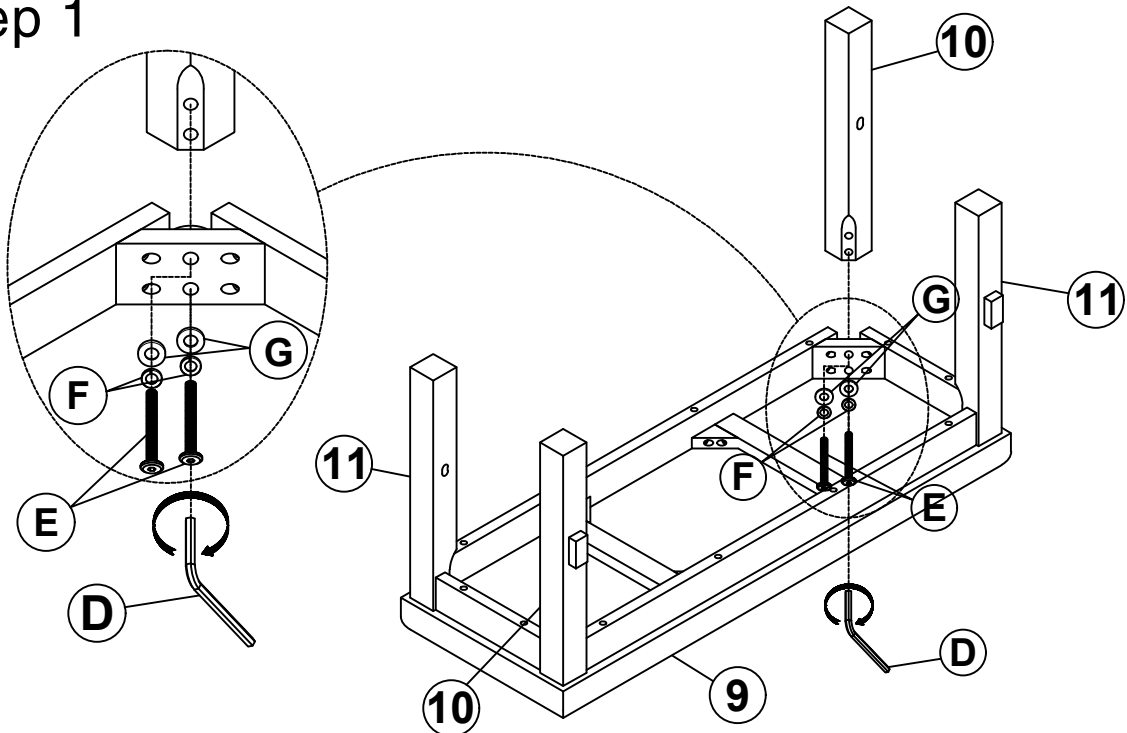

PART LIST FOR ONE BENCH	HARDWARE LIST FOR ONE BENCH
<p>⑨</p>  <p>SEAT BENCH (1pc)</p>	<p>Ⓔ</p>  <p>Ø5/16" x 60mm BOLT (8pcs)</p>
<p>⑩</p>  <p>LEGS BENCH (2pcs)</p>	<p>Ⓕ</p>  <p>Ø5/16" x 13mm SPRING WASHER (8pcs)</p>
<p>⑪</p>  <p>LEGS BENCH (2pcs)</p>	<p>Ⓖ</p>  <p>Ø5/16" x 19mm FLAT WASHER (8pcs)</p>
<p>⑫</p>  <p>SHORT STRETCHER (2pcs)</p>	<p>Ⓗ</p>  <p>Ø4" x 38mm SCREW (4pcs)</p>
<p>⑬</p>  <p>LONG STRETCHER (2pcs)</p>	<p>Ⓐ</p>  <p>Ø4" x 25mm SCREW (4pcs)</p>
	<p>Ⓓ</p>  <p>4mm ALLENKEY (1pc)</p>
	<p>ASSEMBLY TOOLS REQUIRED (NOT INCLUDED)</p> 

ASSEMBLY INSTRUCTIONS

Step 1

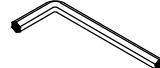

E	5/16x60		8PCS	F	5/16x13		8PCS
D	4x58		1PC	G	5/16x19		8PCS

Step 2

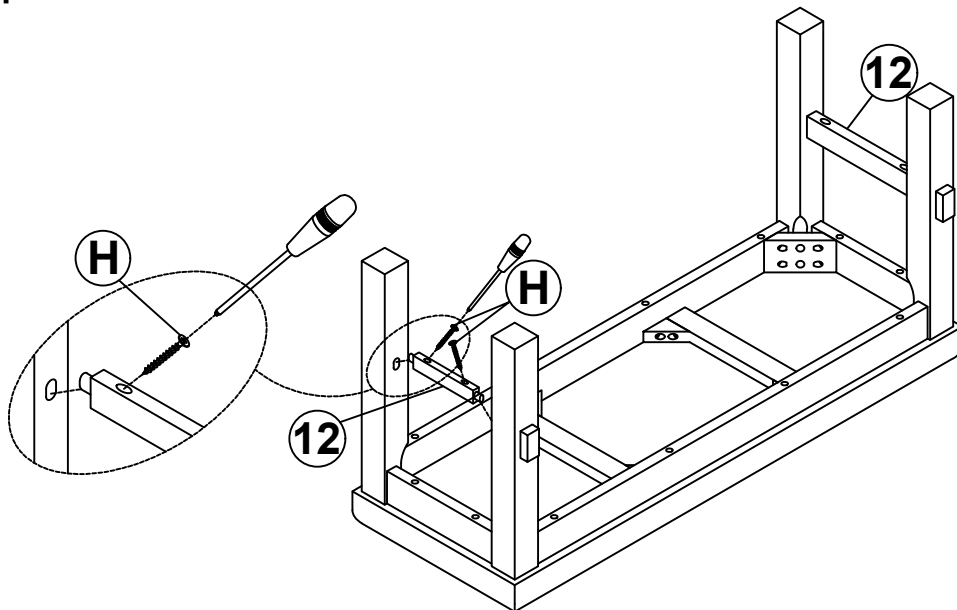

H	Ø4x38		4PCS
----------	-------	---	------

ASSEMBLY INSTRUCTIONS

Step 3

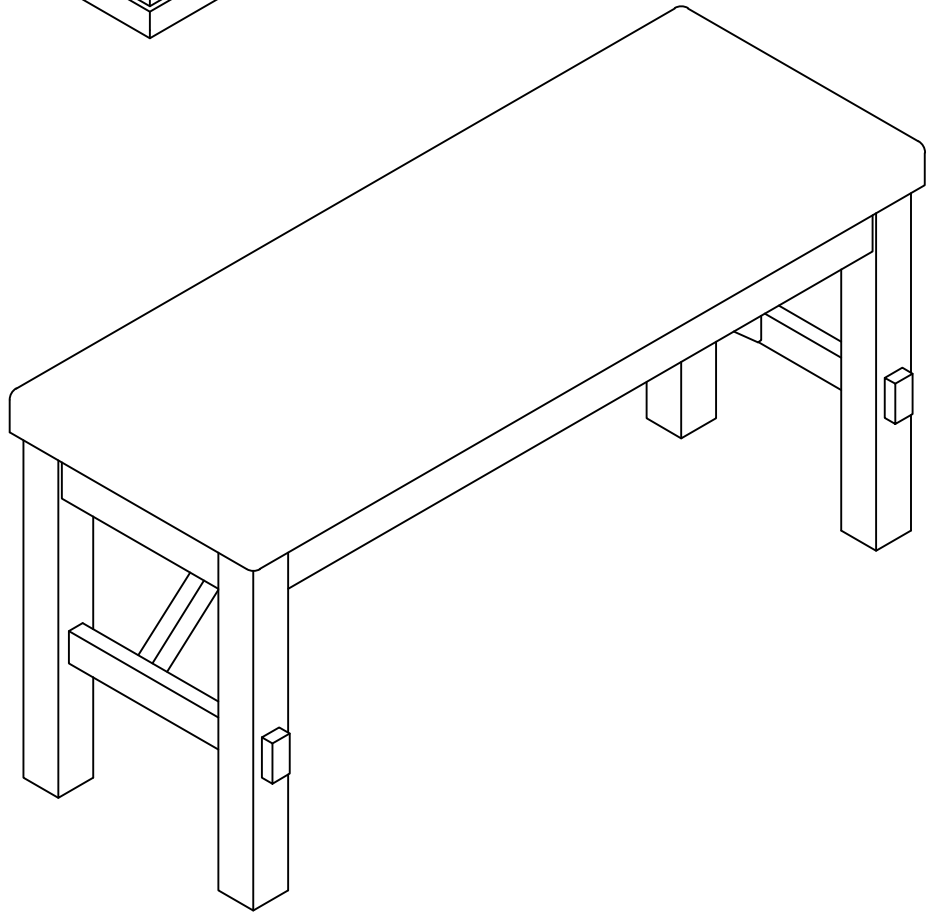
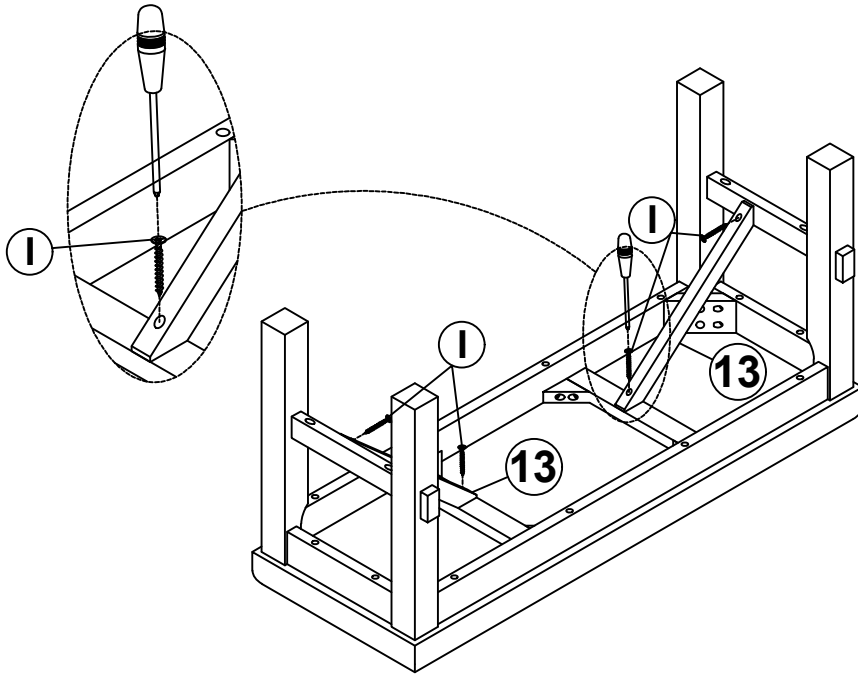

I	Ø4x25		4PCS
---	-------	---	------

ASSEMBLY INSTRUCTIONS

DINING CHAIR

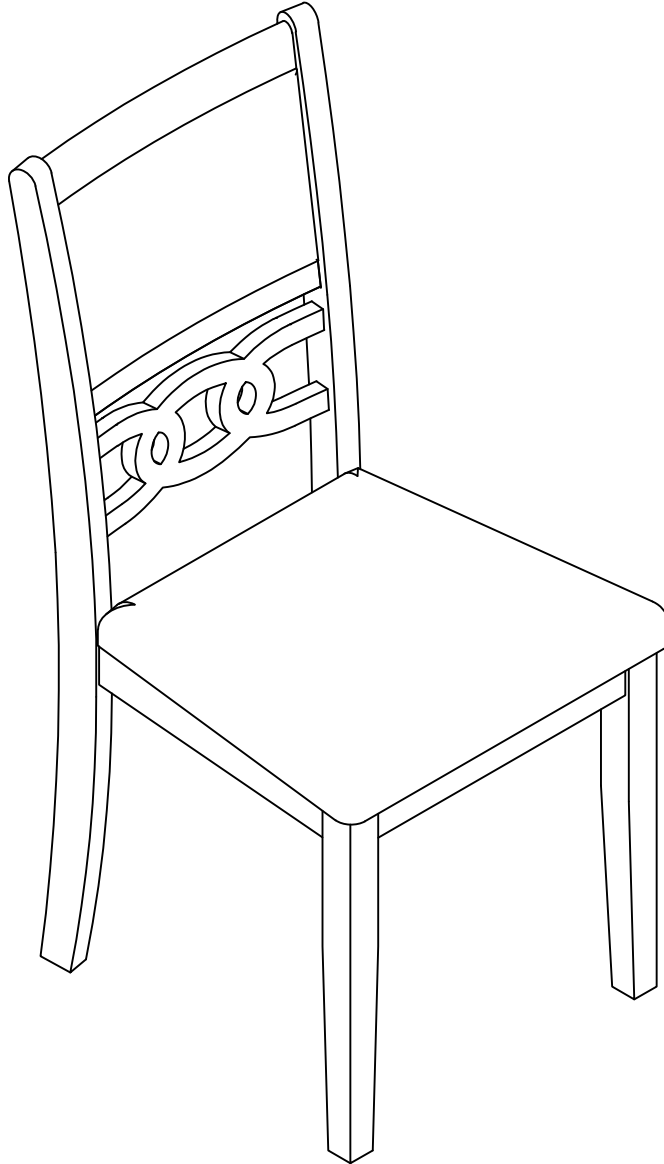

WF303490

IMPORTANT NOTE :

- ① PLACE ALL PARTS ON A CLEAN AND SMOOTH SURFACE SUCH AS A RUG OR CARPET TO AVOID THE PARTS FROM BEING SCRATCHED.
- ② BEFORE YOU BEGIN , KINDLY FOLLOW THE ASSEMBLY INSTRUCTIONS STEP BY STEP.
- ③ DO NOT TIGHTEN ALL SCREWS AND BOLTS UNTIL THE CHAIR IS FULLY SET-UP

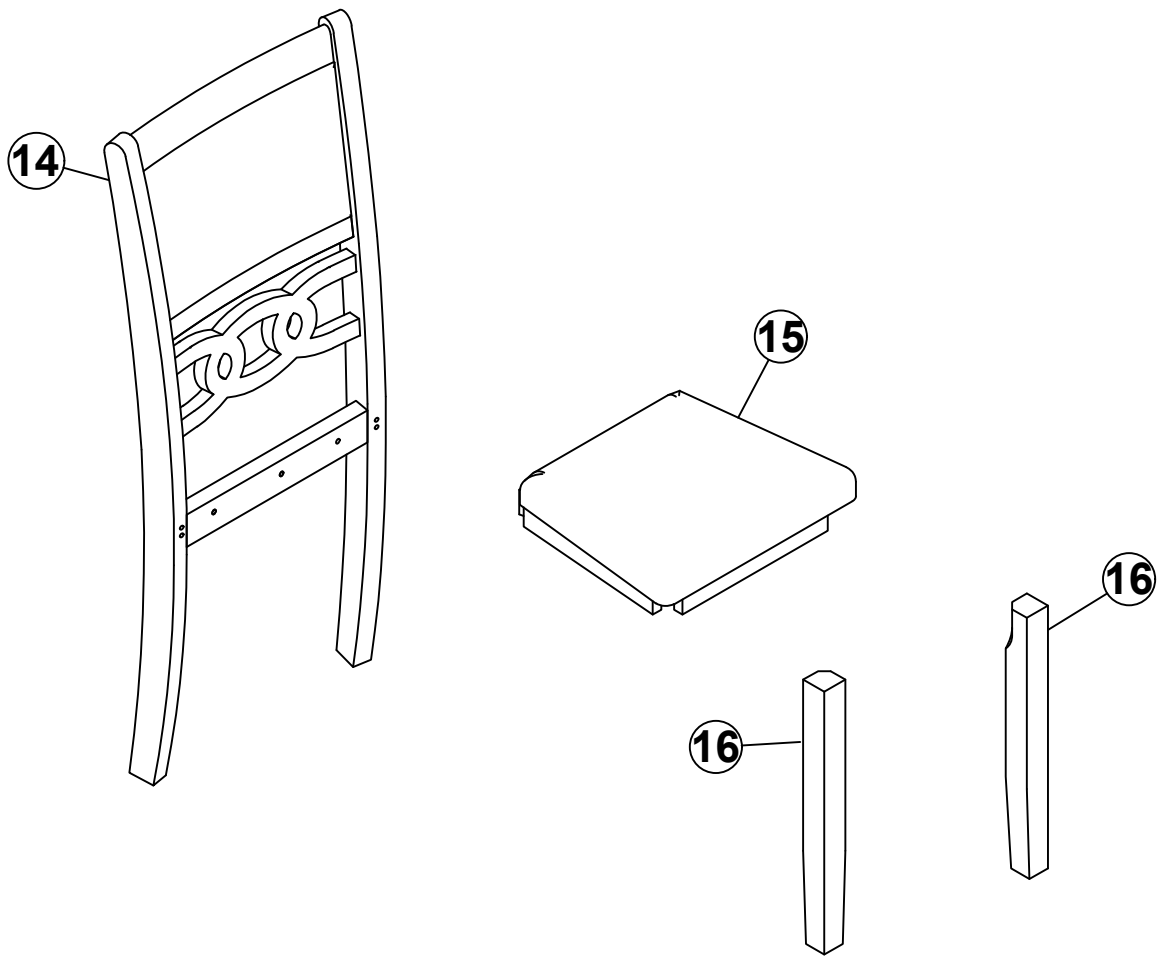

Part List For One Chair

14

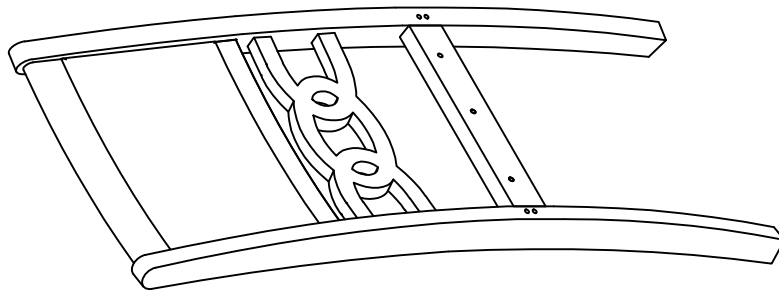

BACK FRAME (1pc)

15

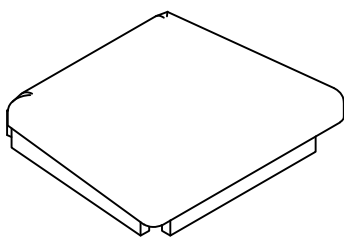





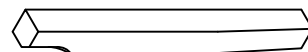

SEAT FRAME (1pc)

16

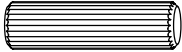



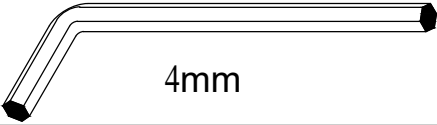

LEGS CHAIR (2pcs)

Hardware List For One Chair

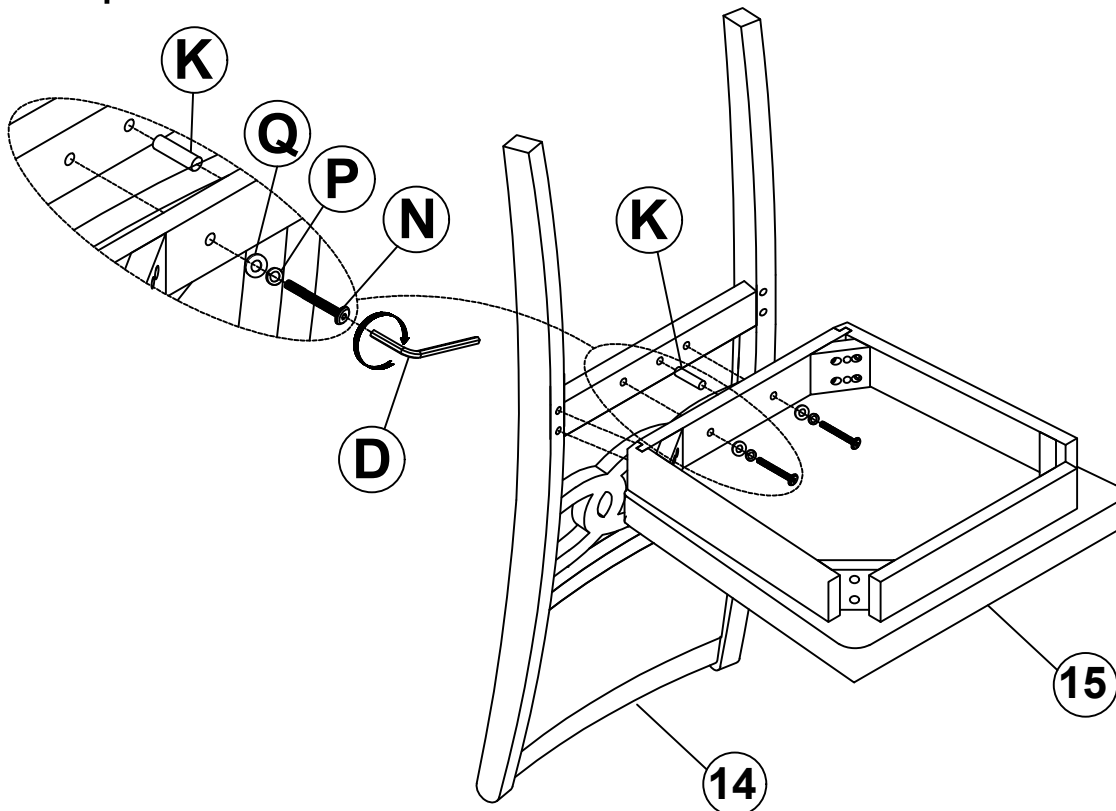
K	 Ø10 x 30mm WOODEN PEGS (1pc)	P	 Ø1/4" x 13mm SPRING WASHER (10pcs)
L	 Ø1/4" x 75mm BOLT (4pcs)	Q	 Ø1/4" x 19mm FLAT WASHER (10pcs)
M	 Ø1/4" x 55mm BOLT (4pcs)	D	 4mm ALLENKEY (1pc)
N	 Ø1/4" x 35mm BOLT (2pcs)		



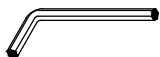

Step 1

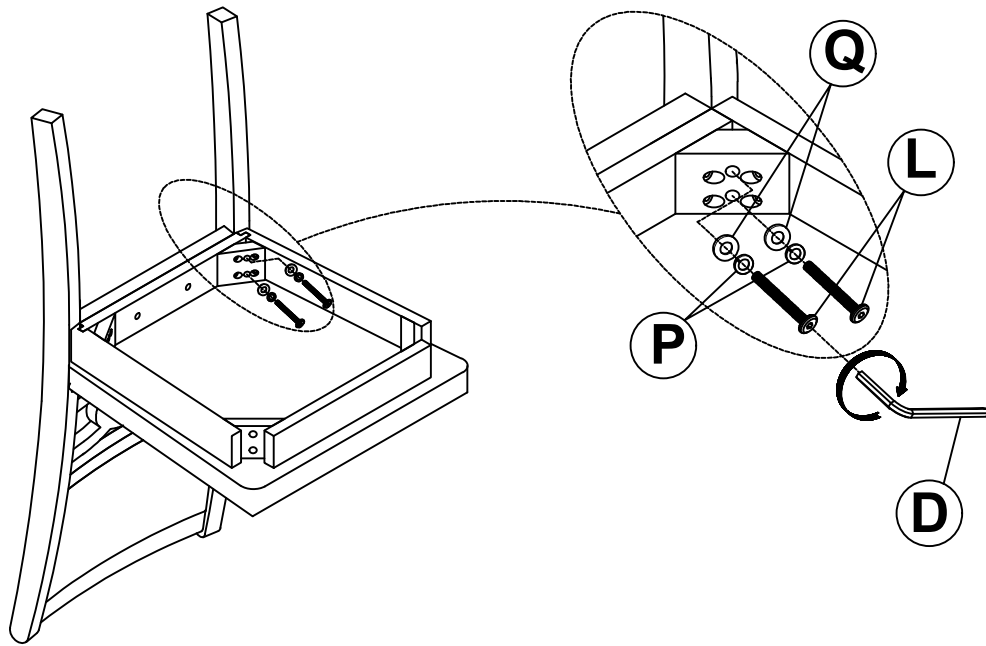

K	Ø10x30		1PC	P	Ø1/4"x13		2PCS
N	Ø1/4"x35		2PCS	Q	Ø1/4"x19		2PCS
				D	4x58		1PC





Step 2

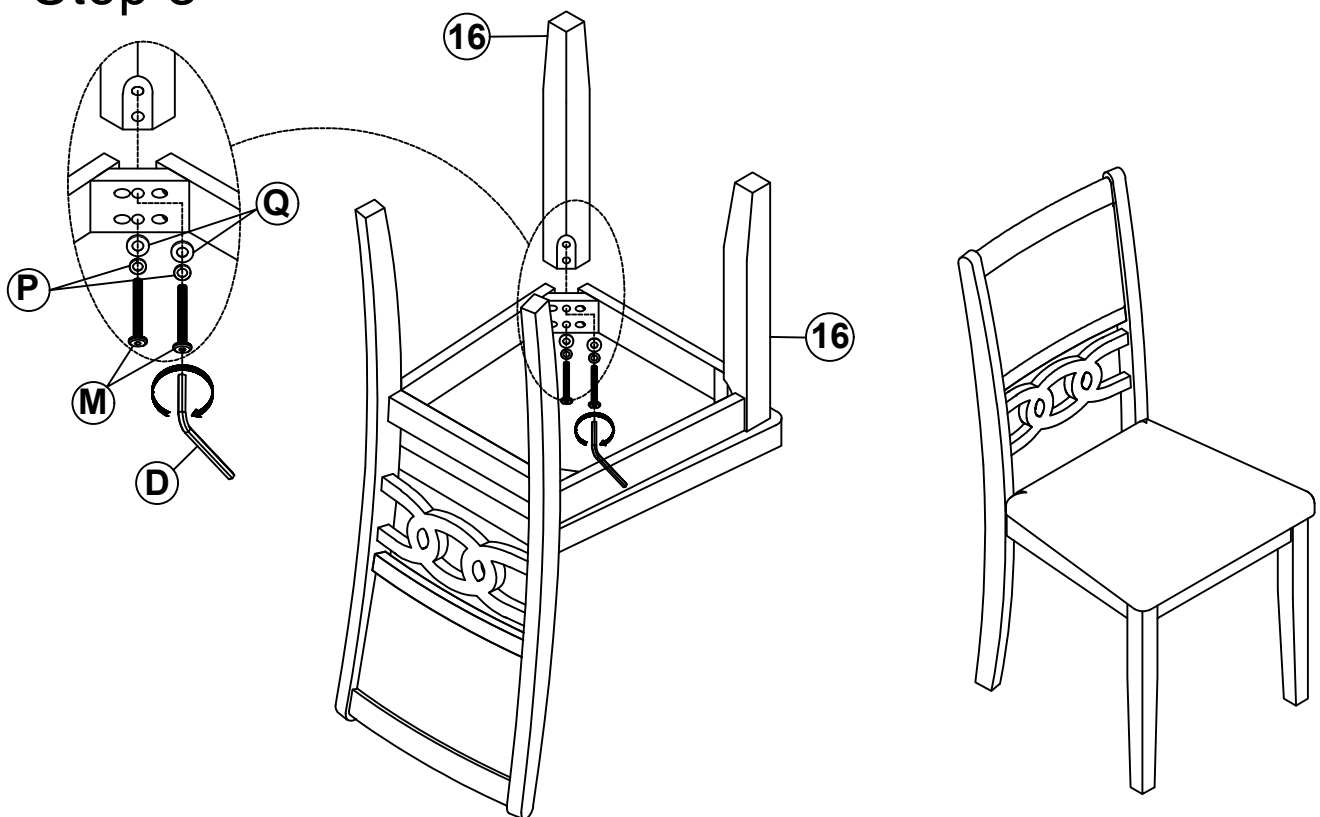

D	4x58		1PC	P	Ø1/4"x13		4PCS
L	Ø1/4"x75		4PCS	Q	Ø1/4"x19		4PCS

Step 3



M	Ø1/4"x55		4PCS	Q	Ø1/4"x19		4PCS
P	Ø1/4"x13		4PCS	D	4x58		1PC