







Installation & Assembly



Before You Start

-  Please read all instructions carefully.
-  Retain instructions for future reference.
-  Separate and count all parts and hardware.
-  Read through each step carefully and follow the proper order.
-  We recommend that, where possible, all items are assembled near to the area in which they will be placed in use, to avoid moving the product unnecessarily once assembled.
-  Always place the product on a flat, steady and stable surface.
-  Keep all small parts and packaging materials for this product away from babies and children as they potentially pose a serious choking hazard.

Assembly Instructions

We have designed our furniture with you, the customer in mind. Our clear, easy to follow step by step instructions will guide you through the project from start to finish. Feel confident that this will be a fun and rewarding project. The final product will be a quality piece of furniture that will go together smoothly and give years of enjoyment.

ANTI-TOPPLE WARNING !

Overtipped furniture can cause serious or fatal crush injuries. To prevent tipping over, be sure to use the wall attachment, if not included with this product. Please purchase the wall attachment that fits your wall. If unsure, seek professional advice. Please read and follow each step of the instructions carefully.



Please do not return to the store
Broken or missing Hardware?
Need help with Assembly?
If you have any questions just email us

Completed Assembly

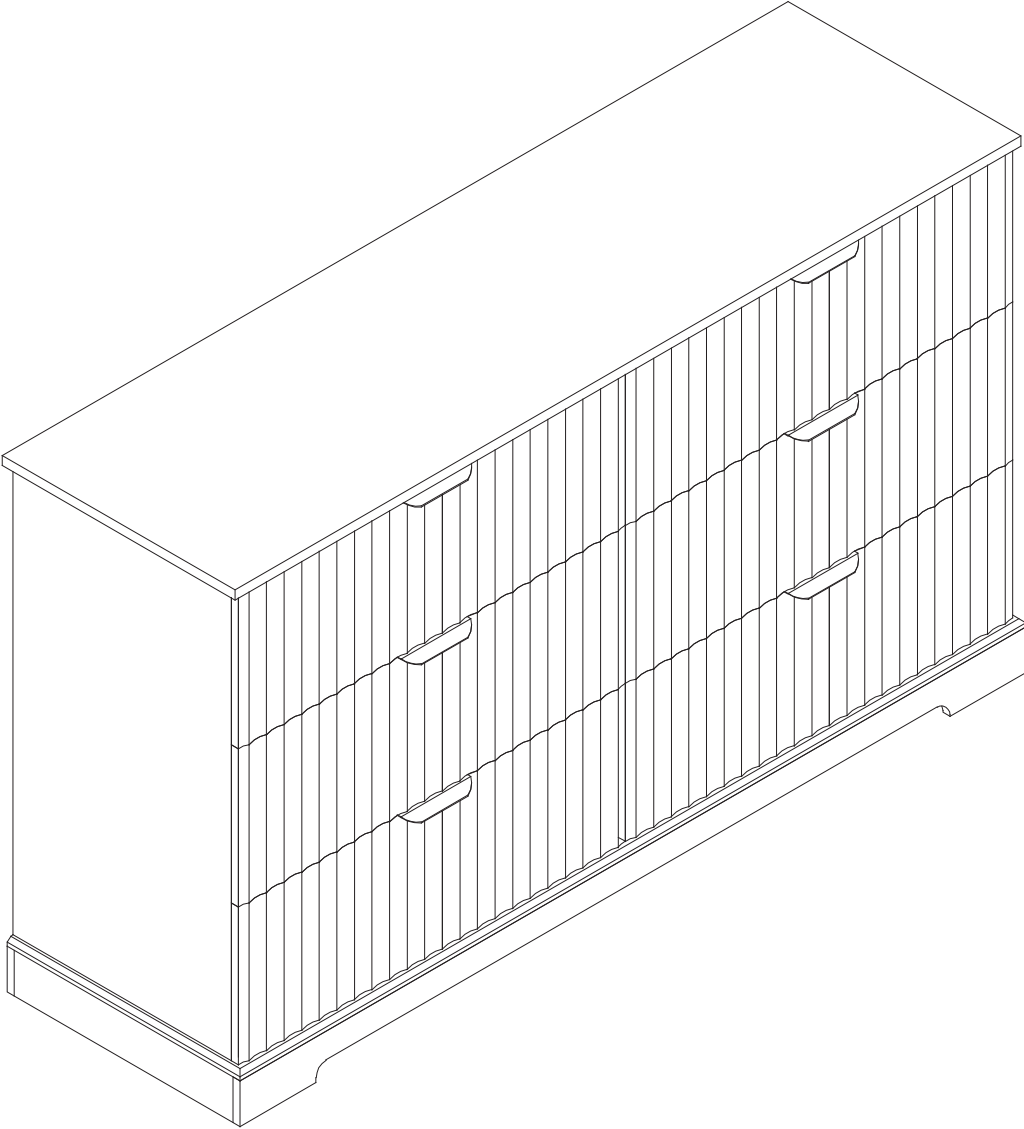

Parts Description

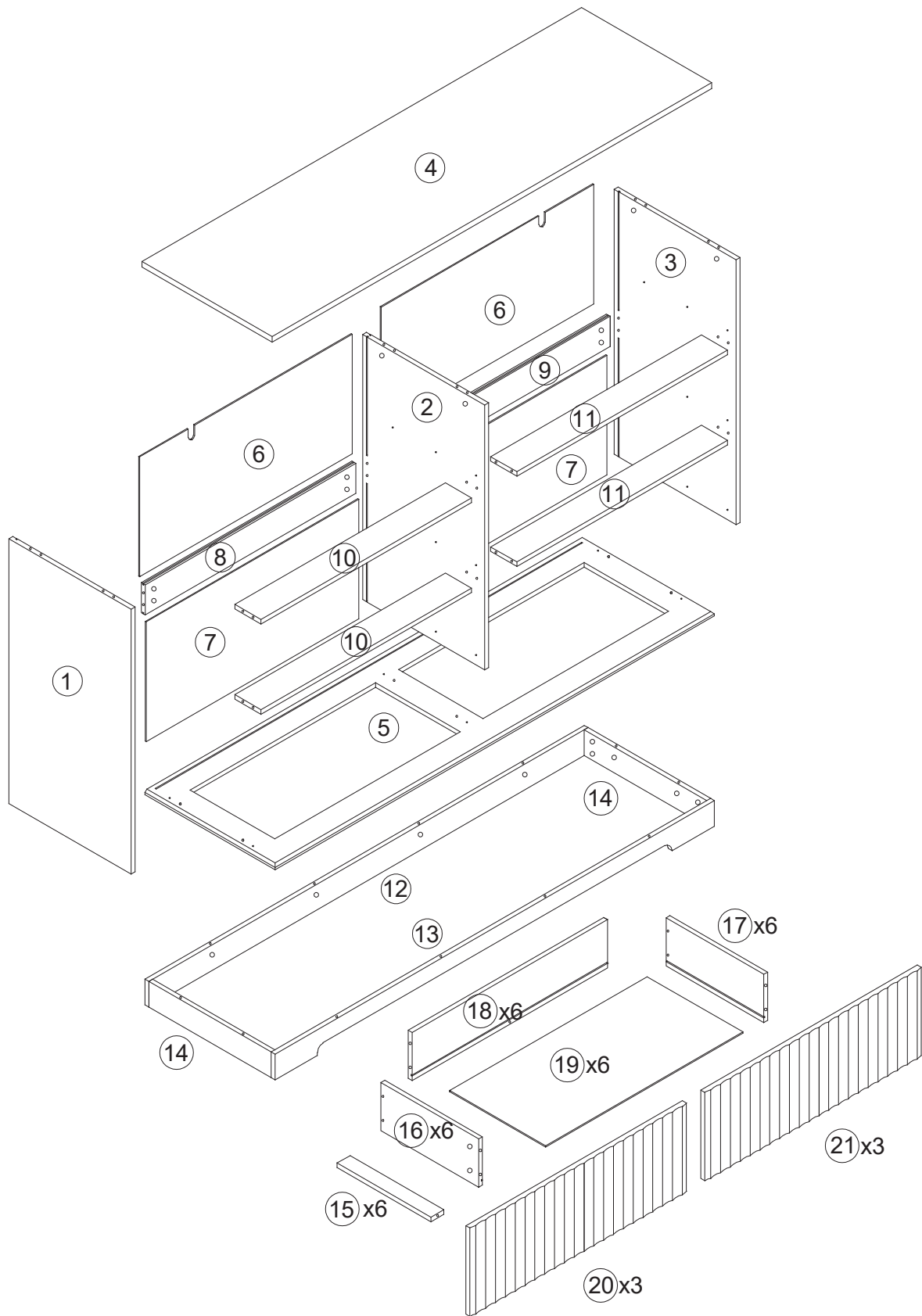

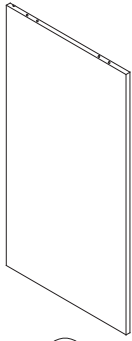

①

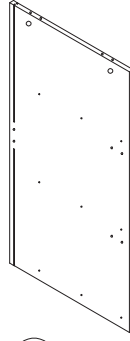

②

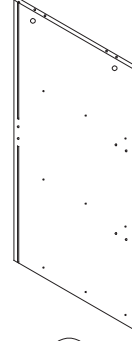

③

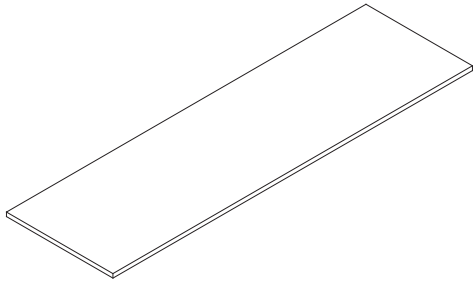

④

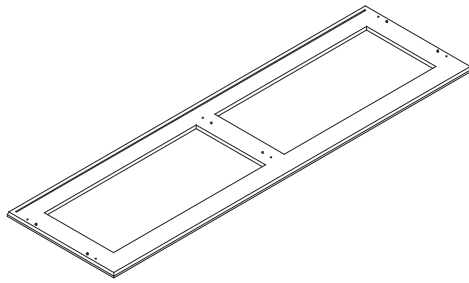

⑤

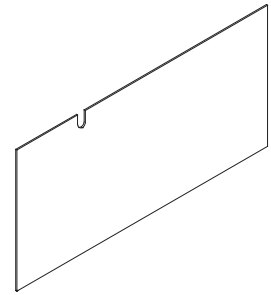

⑥ x2

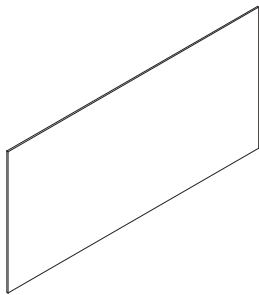

⑦ x2

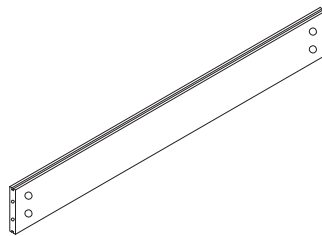

⑧

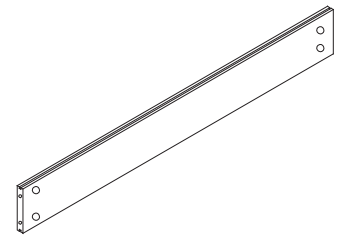

⑨

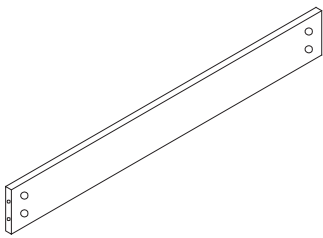

⑩ x2

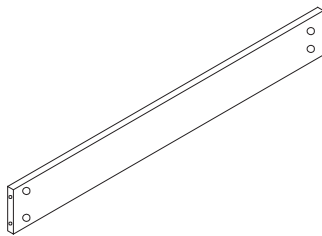

⑪ x2

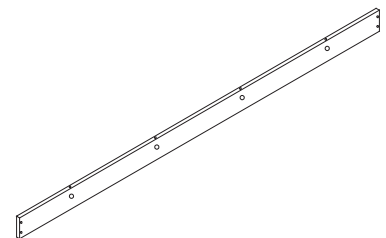

⑫

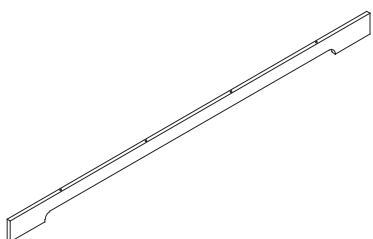

⑬

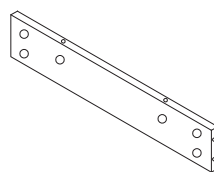

⑭ x2

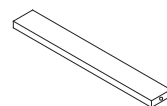

⑮ x6

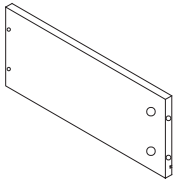

16 x6

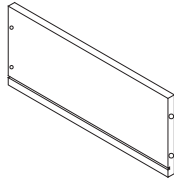

17 x6

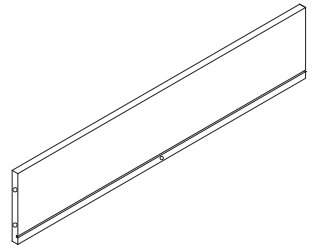

18 x6

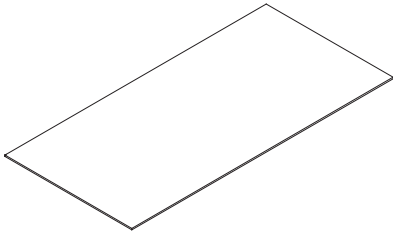



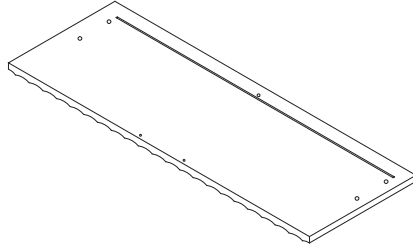

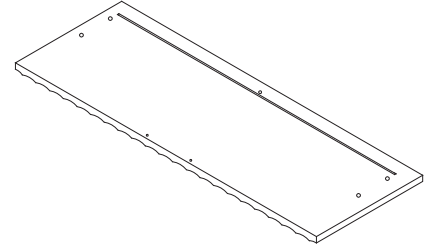

19 x6

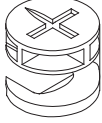

20 x3

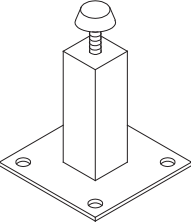
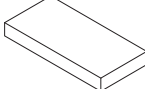
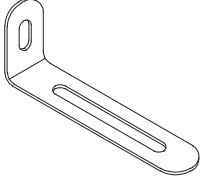

21 x3

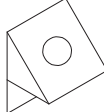
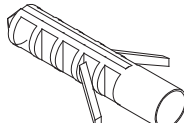
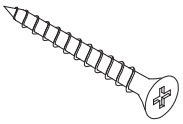
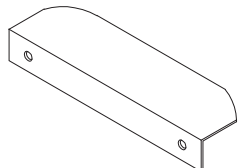
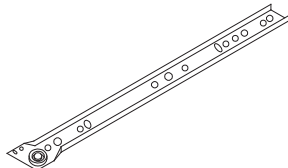
<p>A</p>  <p>Cam Bolt</p> <p>80+2</p>	<p>B</p>  <p>Cam Lock</p> <p>80+2</p>	<p>C</p>  <p>3x12mm Screw</p> <p>72+2</p>
<p>D</p>  <p>8x30mm Wooden Dowel</p> <p>12+1</p>	<p>E</p>  <p>4x30mm Screw</p> <p>36+2</p>	<p>F</p>  <p>4x12mm Screw</p> <p>8</p>
<p>G</p>  <p>1</p>	<p>H</p>  <p>Foot Pad</p> <p>8</p>	<p>I</p>  <p>Tilting Prevention Device</p> <p>2</p>
<p>J</p>  <p>3x15mm Screw</p> <p>8</p>	<p>K</p>  <p>Rear Panel Hooks</p> <p>8</p>	<p>L</p>  <p>Anchor</p> <p>2</p>
<p>M</p>  <p>4x35mm Screw</p> <p>2</p>	<p>N</p>  <p>Knob</p> <p>6</p>	<p>CL</p>  <p>Left Glider</p> <p>6</p>

CR

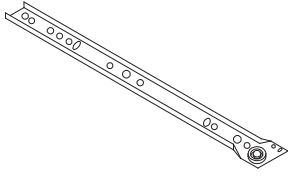

DL

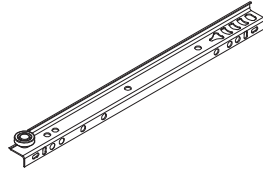

DR

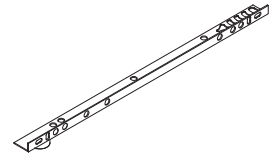

Right Glider

6

Left Slider

6

Right Slider

6



Note: Please do not use any power tools. Use of power tools may cause damage and void manufacture warranty.

Instructions For Fastening Cam Bolt and Cam Lock



CAM BOLT



CAM LOCK

Cam Bolt

Place Cam Bolt on the designated pre-drilled hole on the panel. Use a Phillips Screwdriver to screw in Cam Bolt vertically until shoulder is snug and flushed with panel. Do not over-tighten or under-tighten Cam-bolt. See illustrations below.

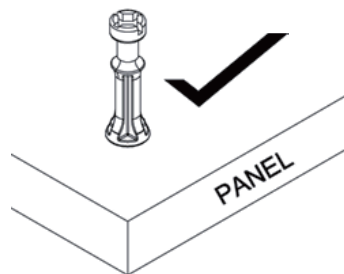
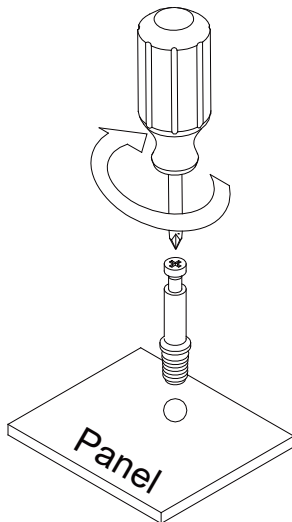

Shoulder is flushed (on the same level) with the panel.

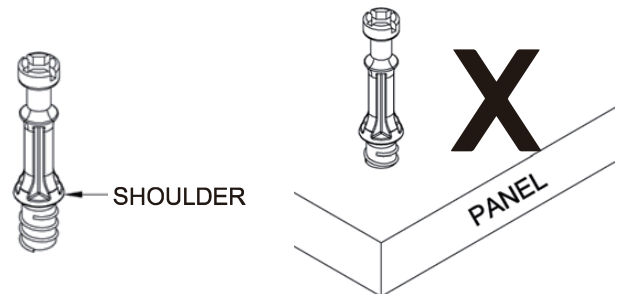

Shoulder is above the panel.

CAM-LOCK

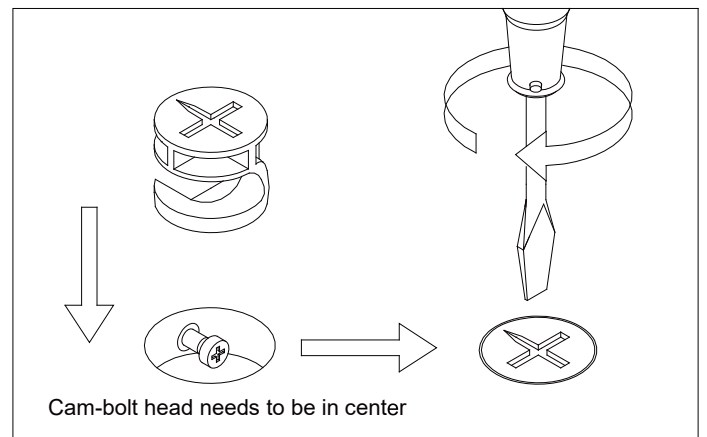
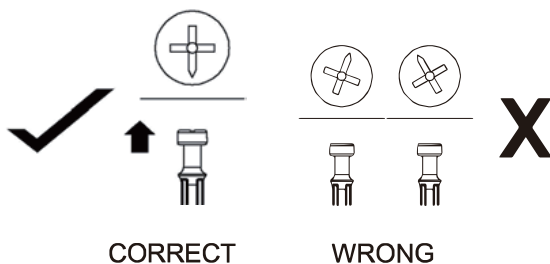

Align the arrow on the Cam-lock to the Cam-bolt head and insert the Cam-lock.

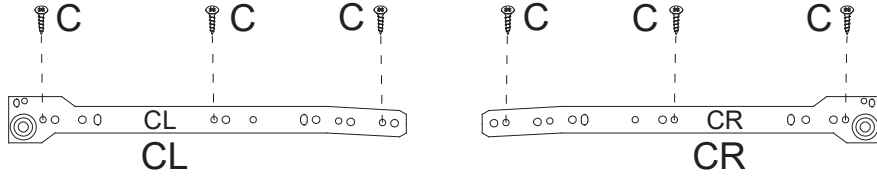

Use a Flat-head Screwdriver to turn Cam Lock clockwise to lock onto the head of the Cam Bolt. Turn until it is snug (about a half turn) – over-tightening could damage Cam Lock and/or Cam Bolt.

Step 1

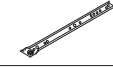

Hardware Needed		
C		X18
CL		X3
CR		X3

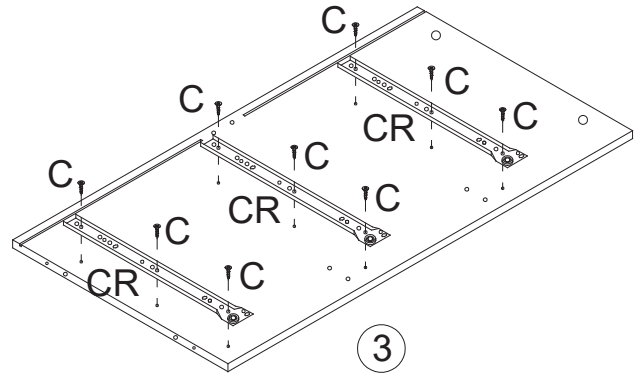
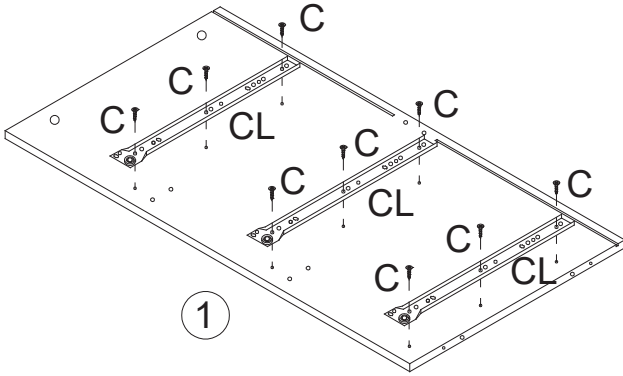

Step 2

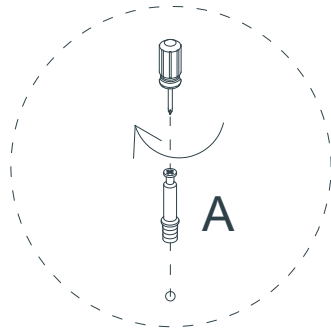

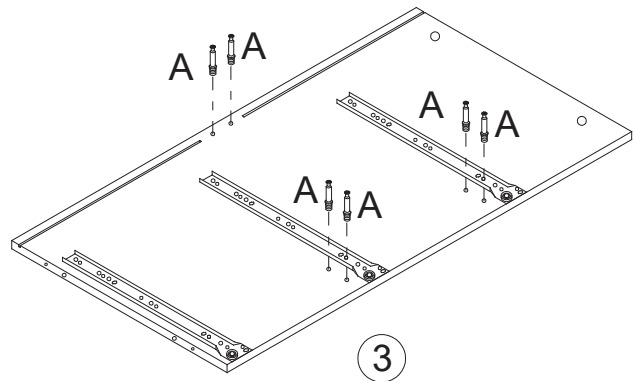
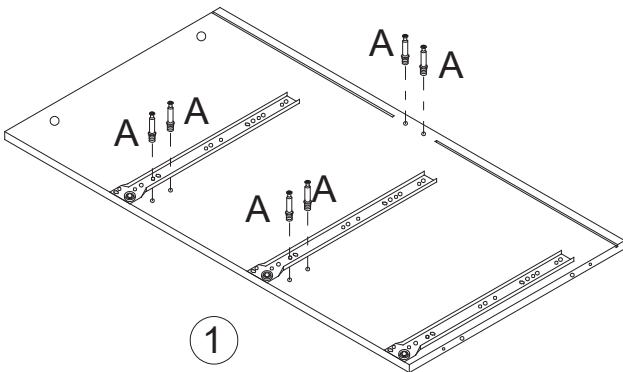

Hardware Needed		
A		X12

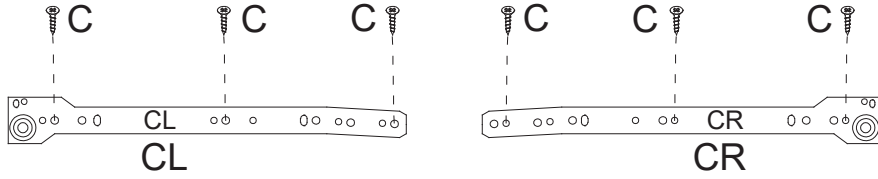

Step 3

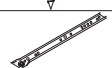

Hardware Needed		
C		X18
CL		X3
CR		X3

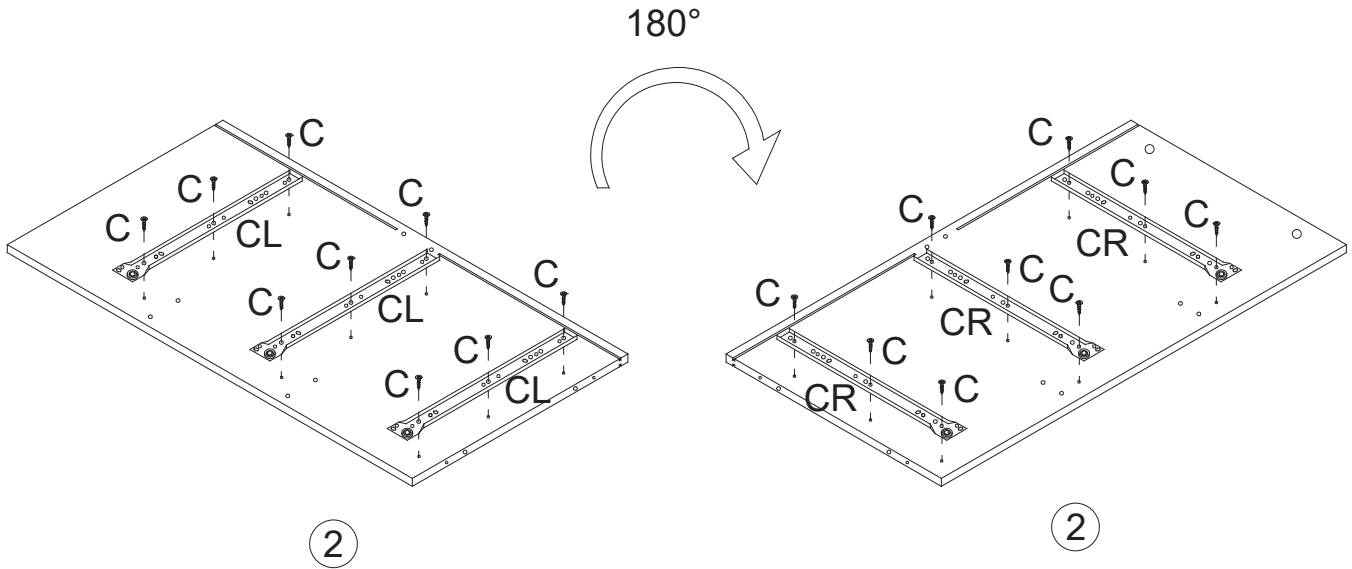

Step 4

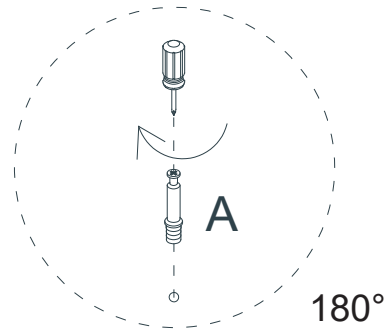

Hardware Needed		
A		X12

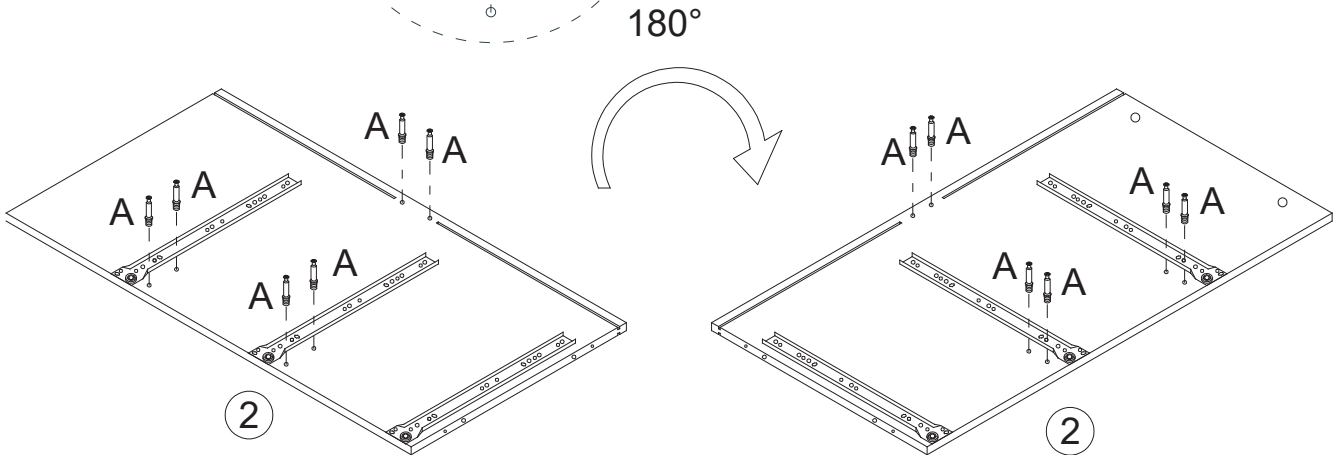

Step 5

Hardware Needed

B		X12
---	---	-----

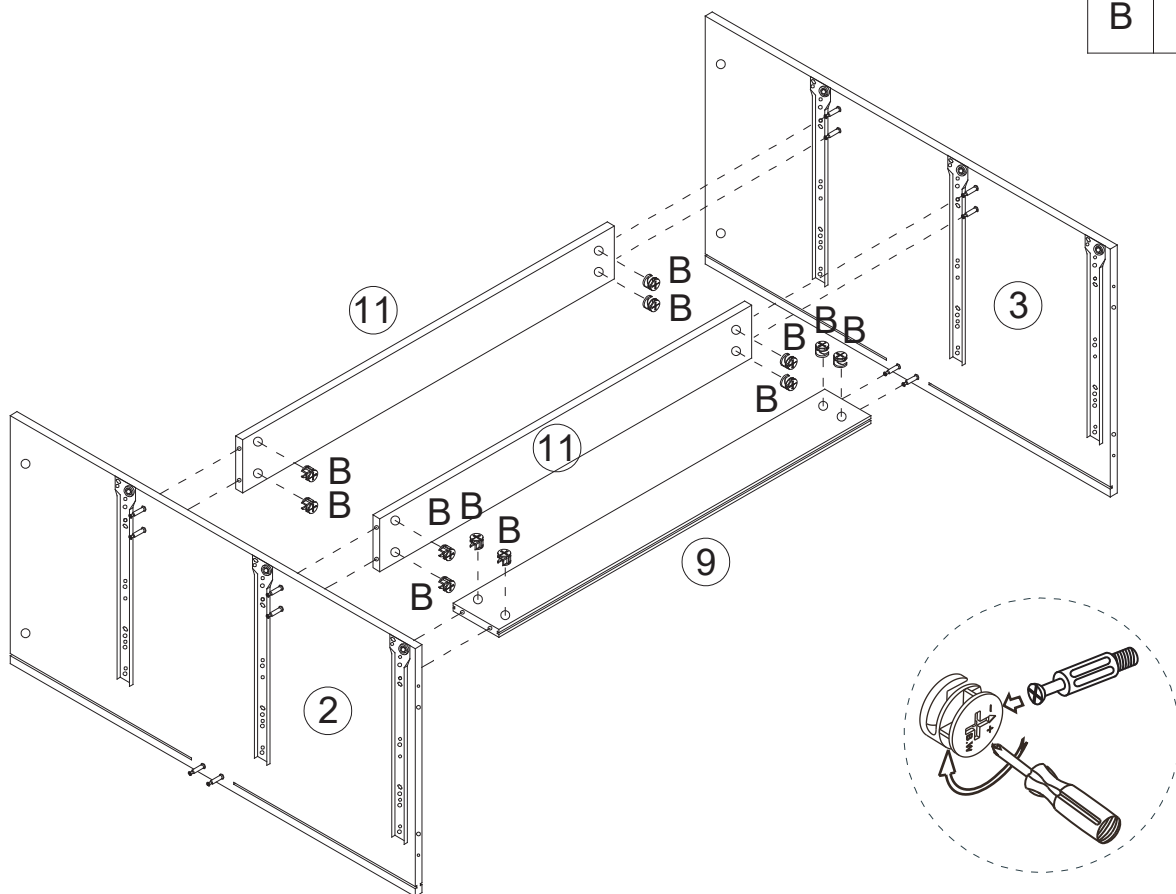

Step 6

Hardware Needed

B		X12
---	---	-----

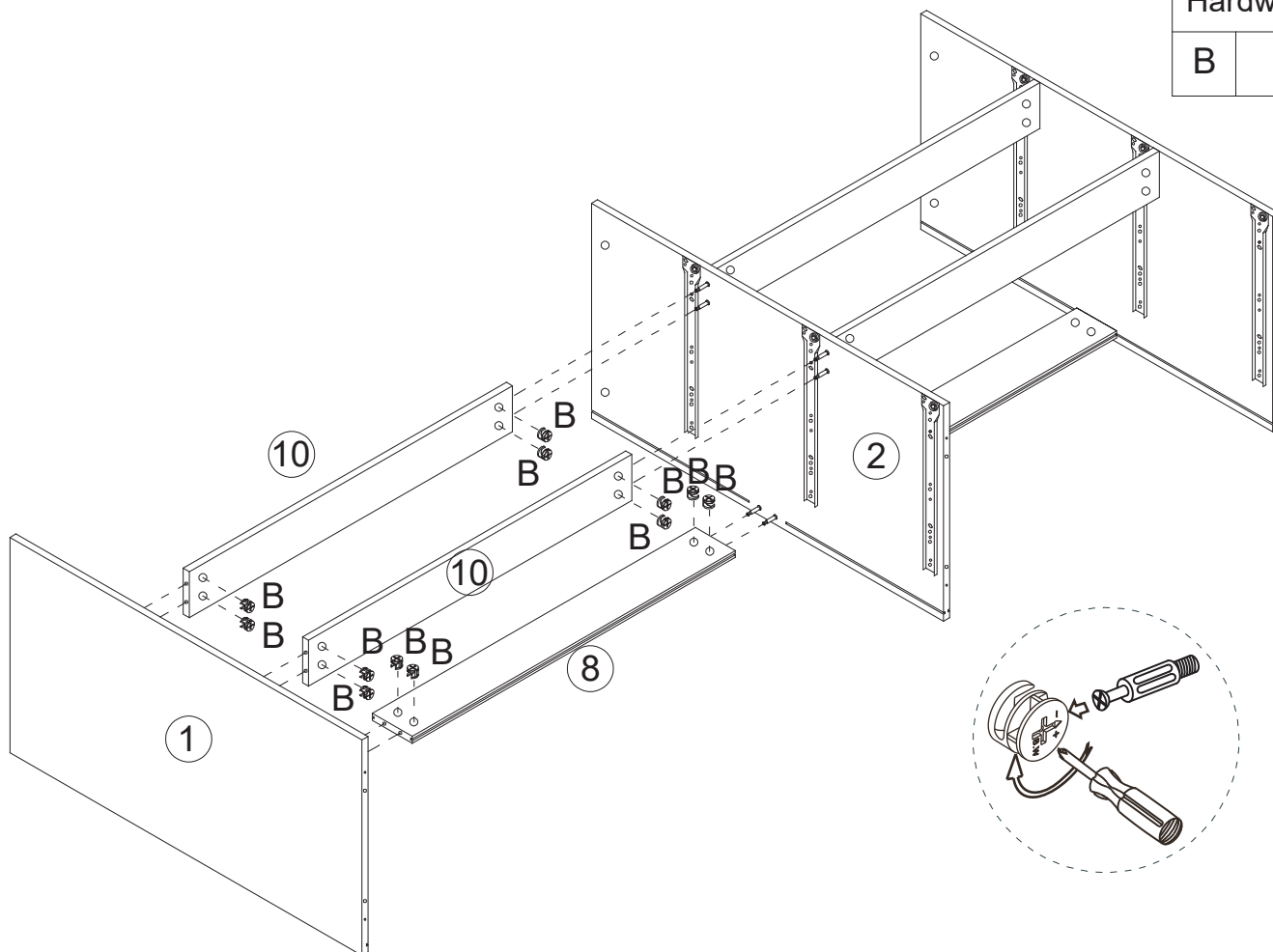

Step 7

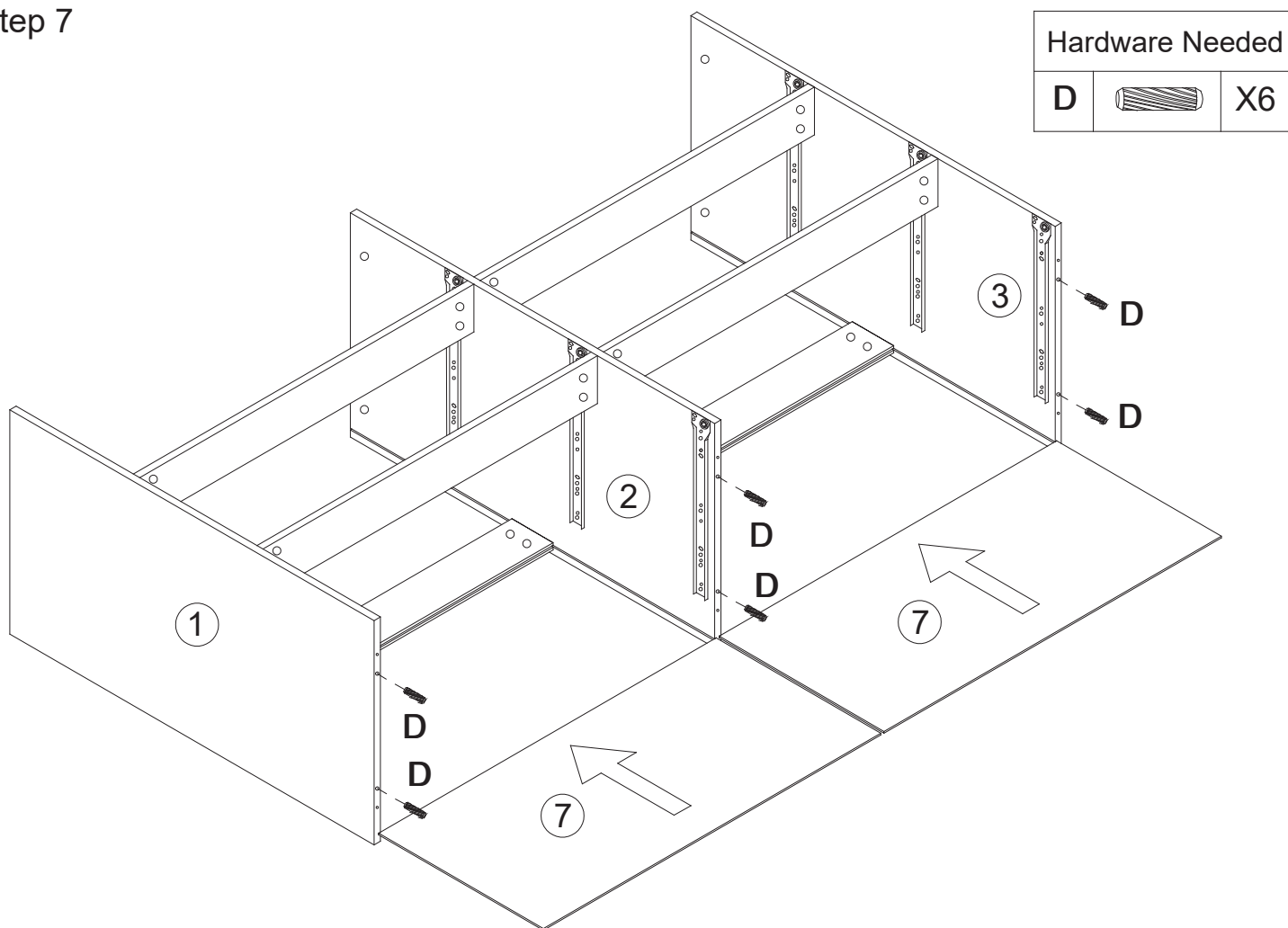

Step 8

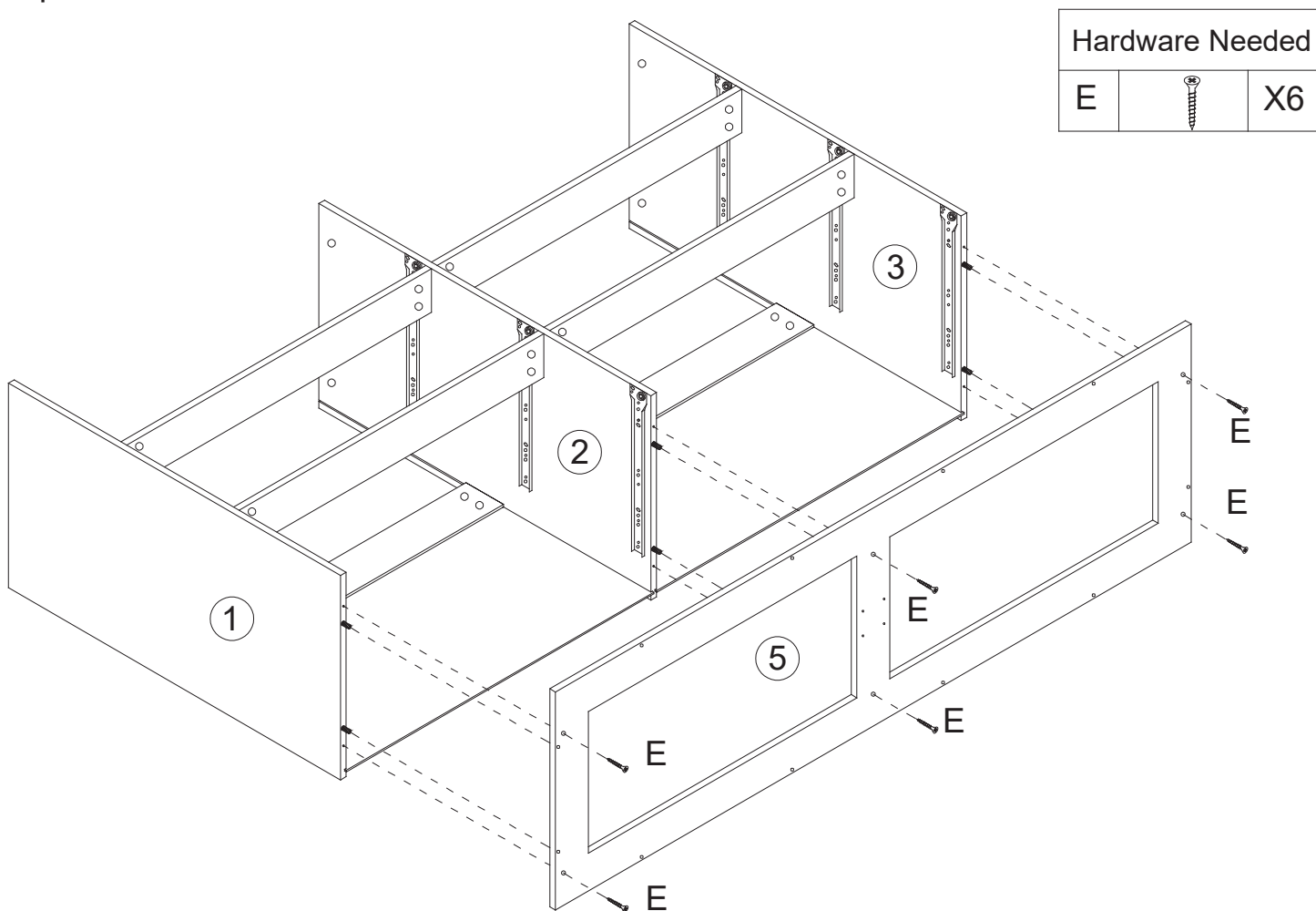

Step 9

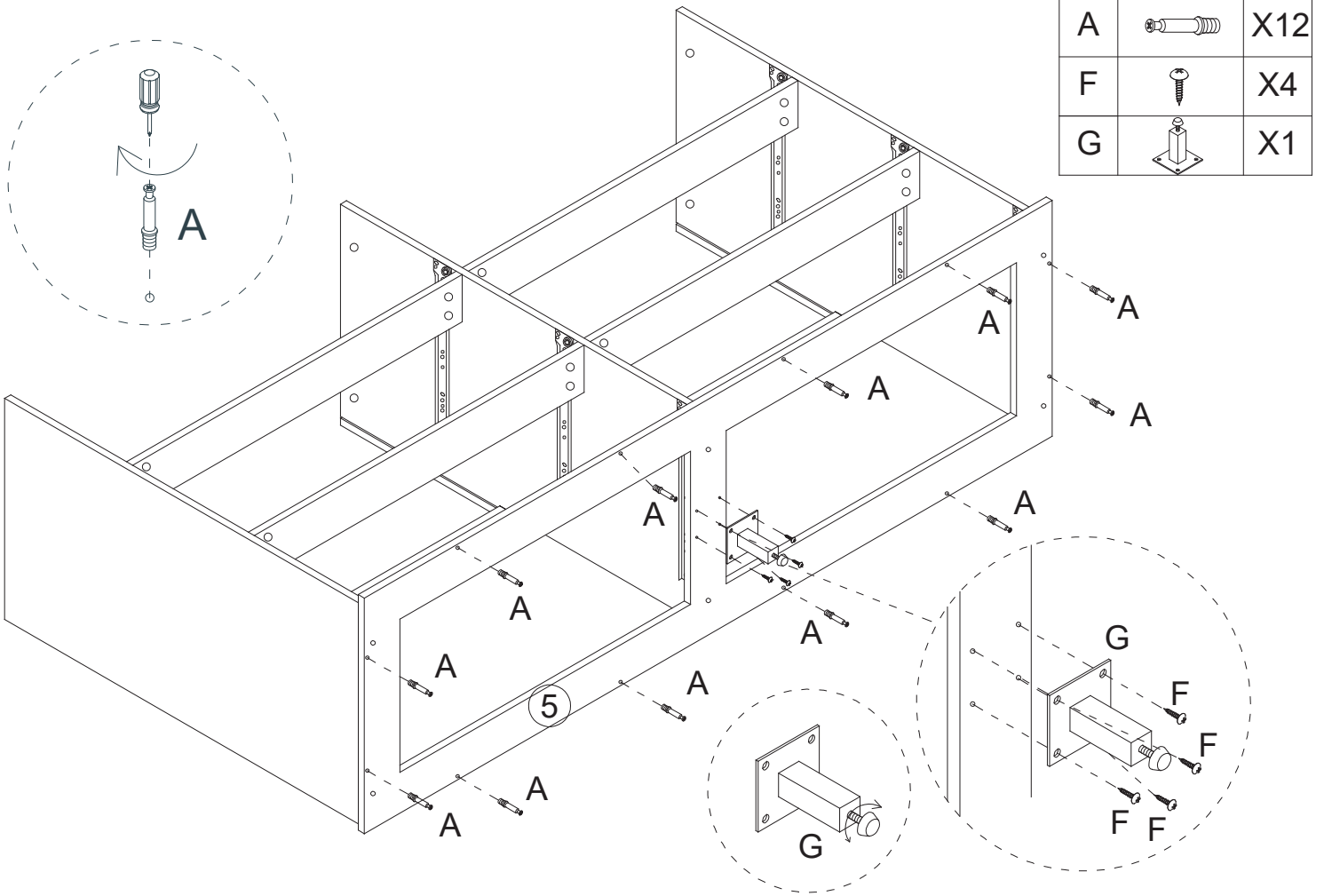

Step 10

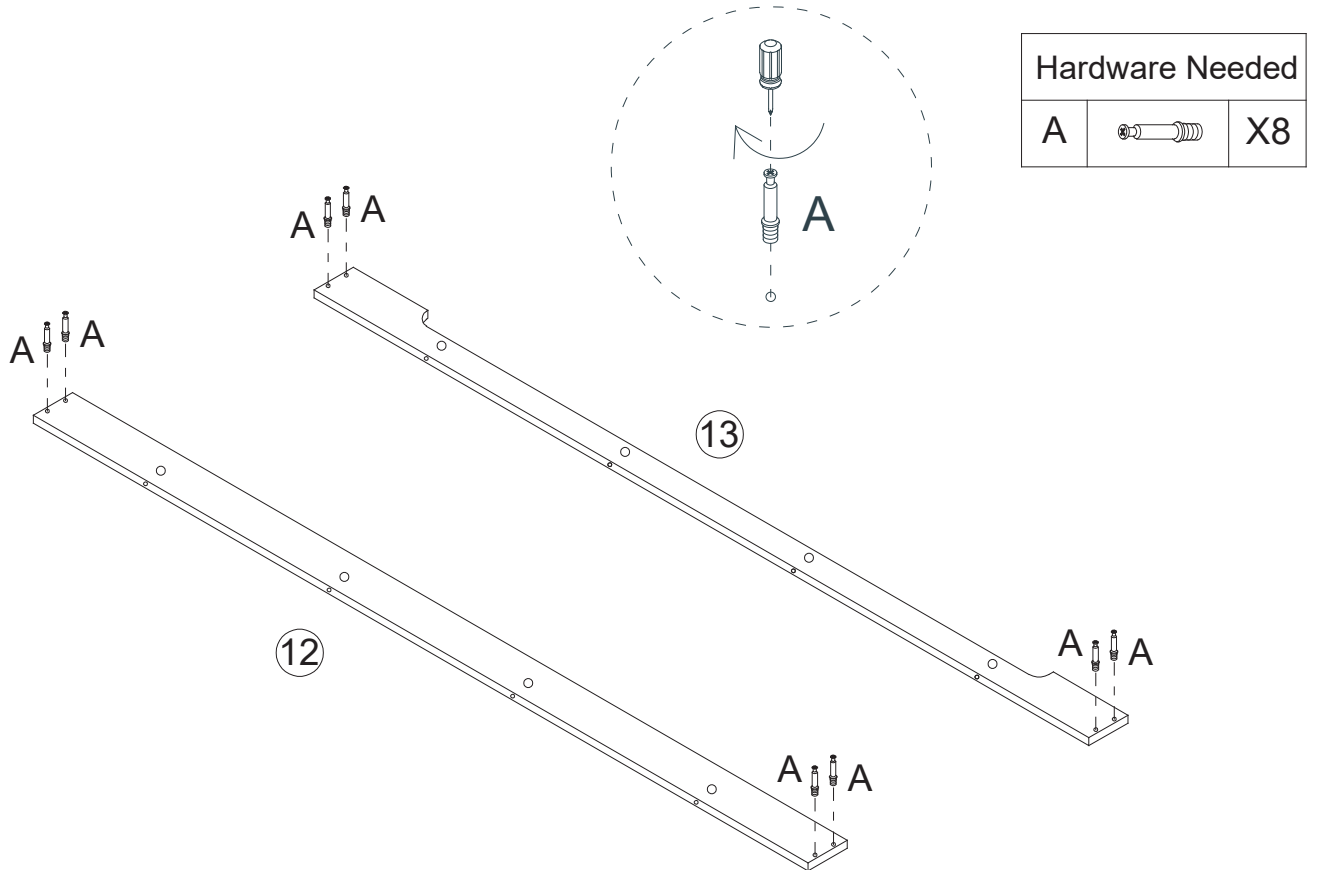

Step 11

Hardware Needed

B		X8
---	---	----

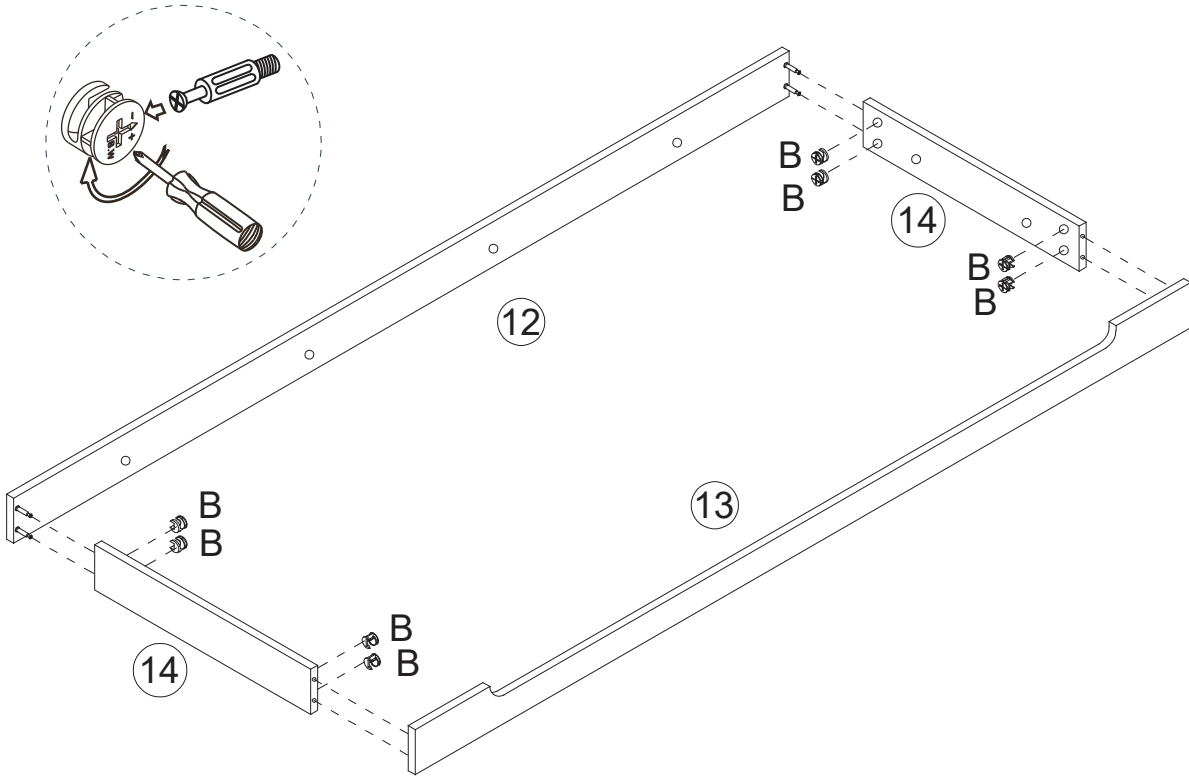

Step 12

Hardware Needed

B		X12
---	---	-----

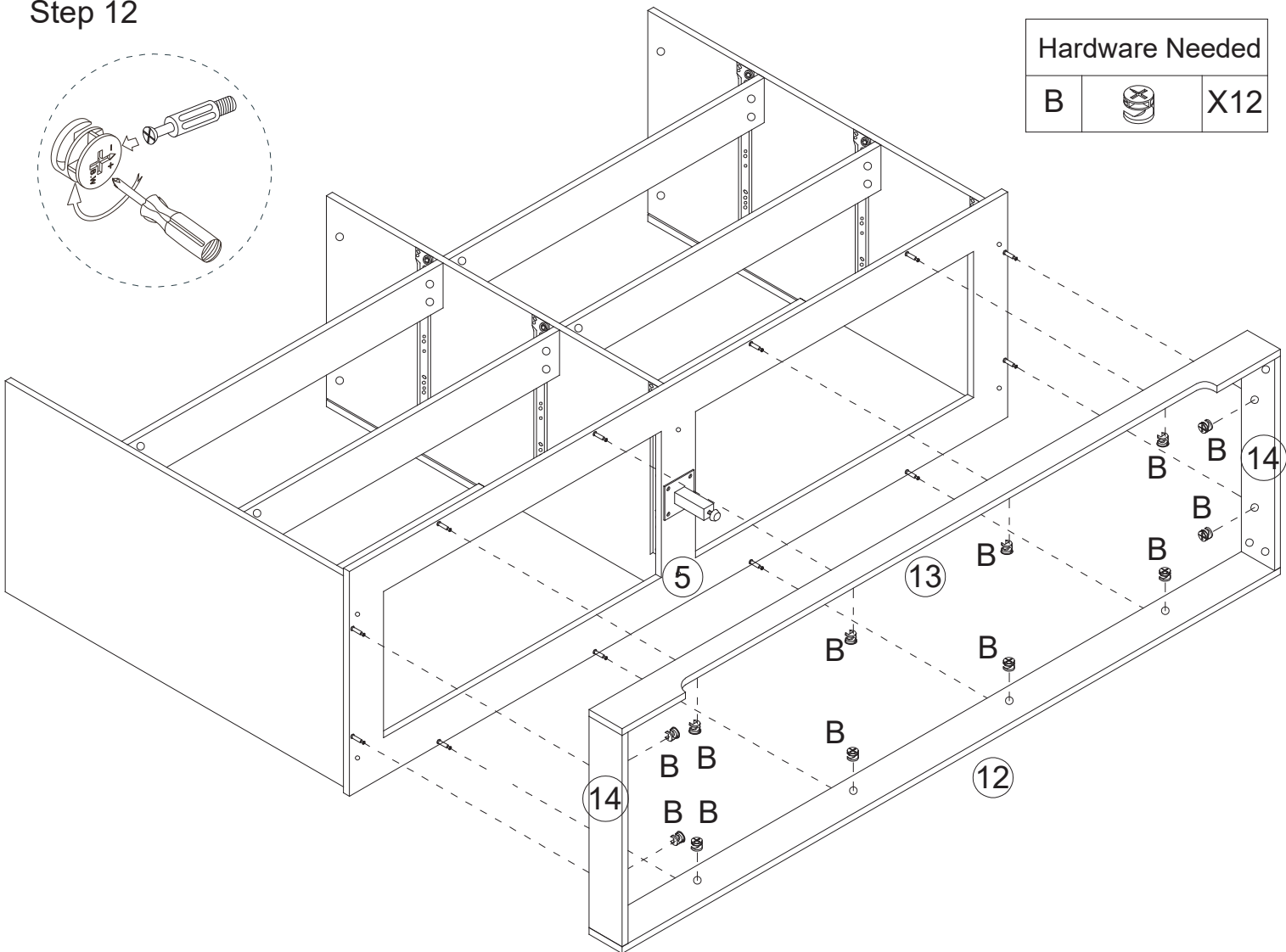

Step 13

Hardware Needed		
H		X8

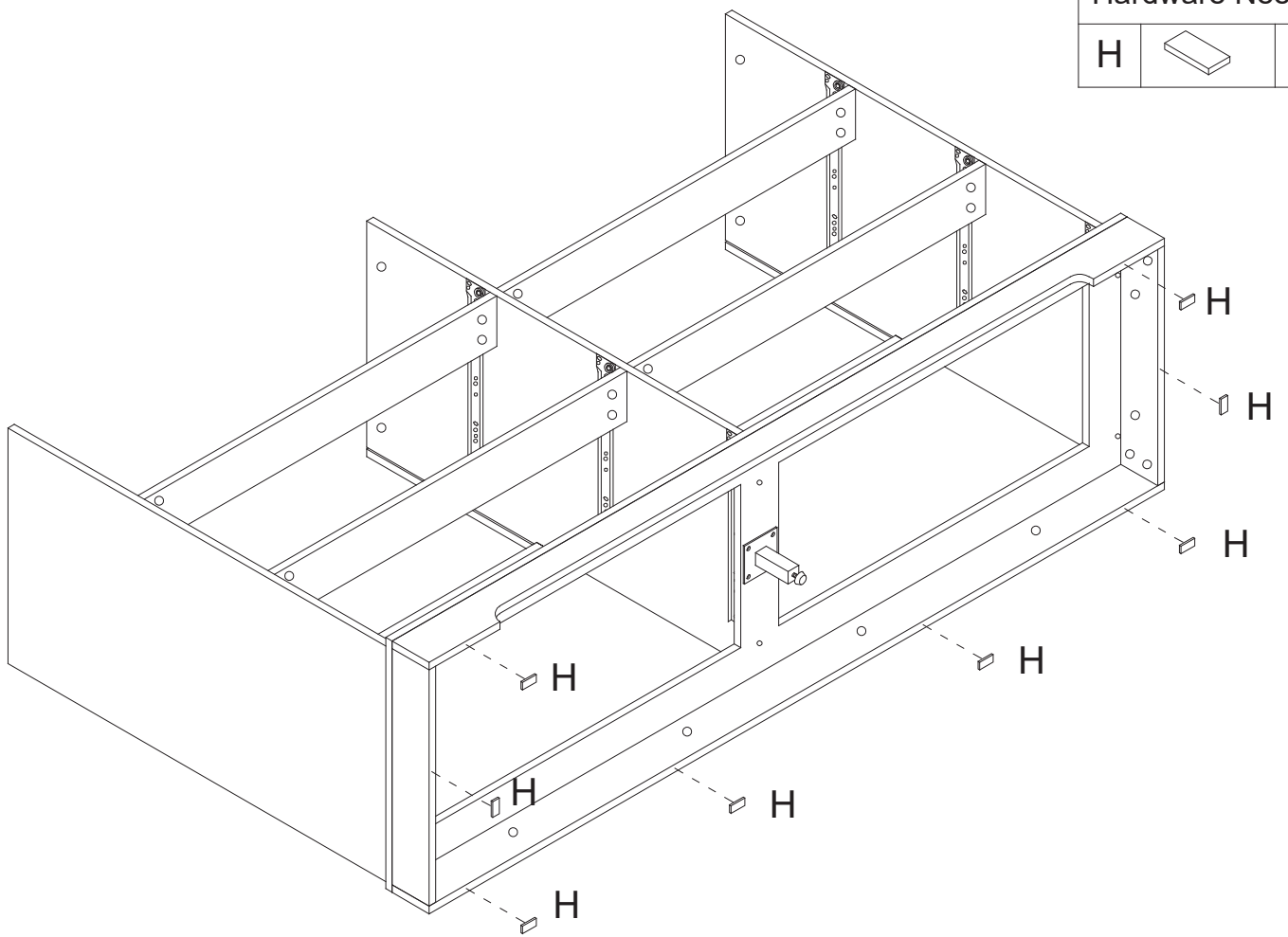



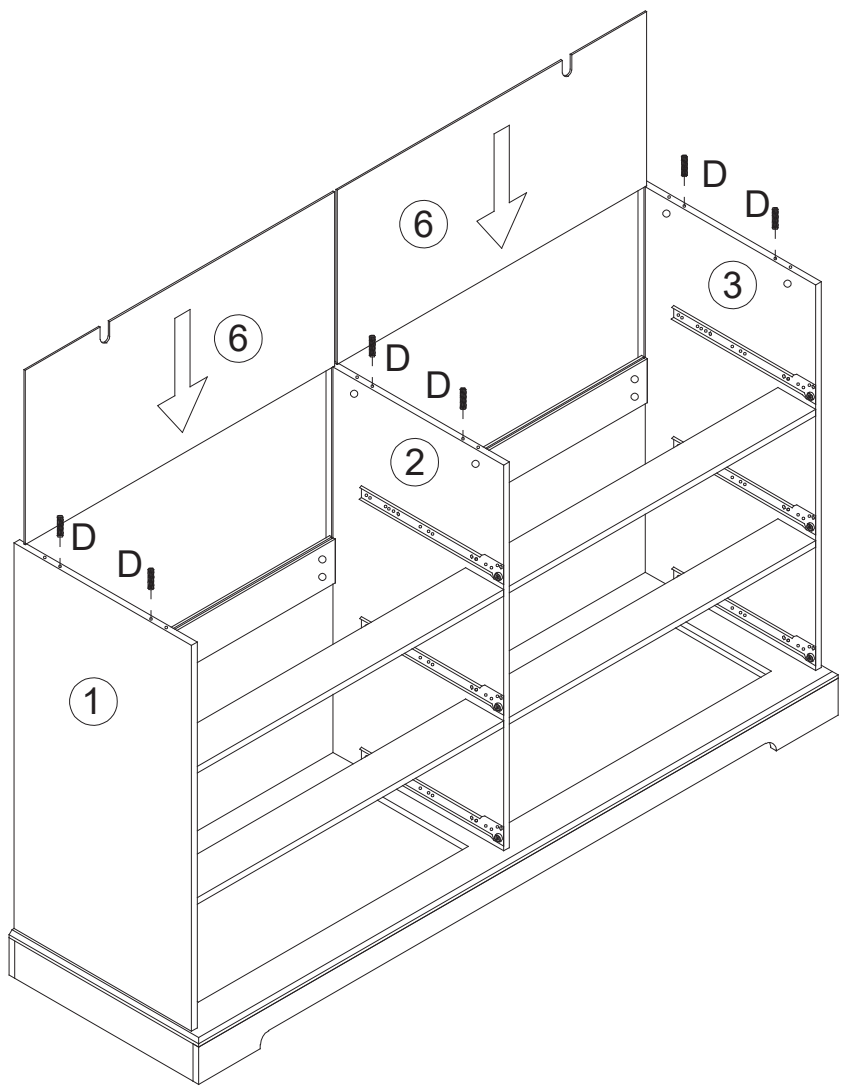

Step 14

Hardware Needed		
D		X6

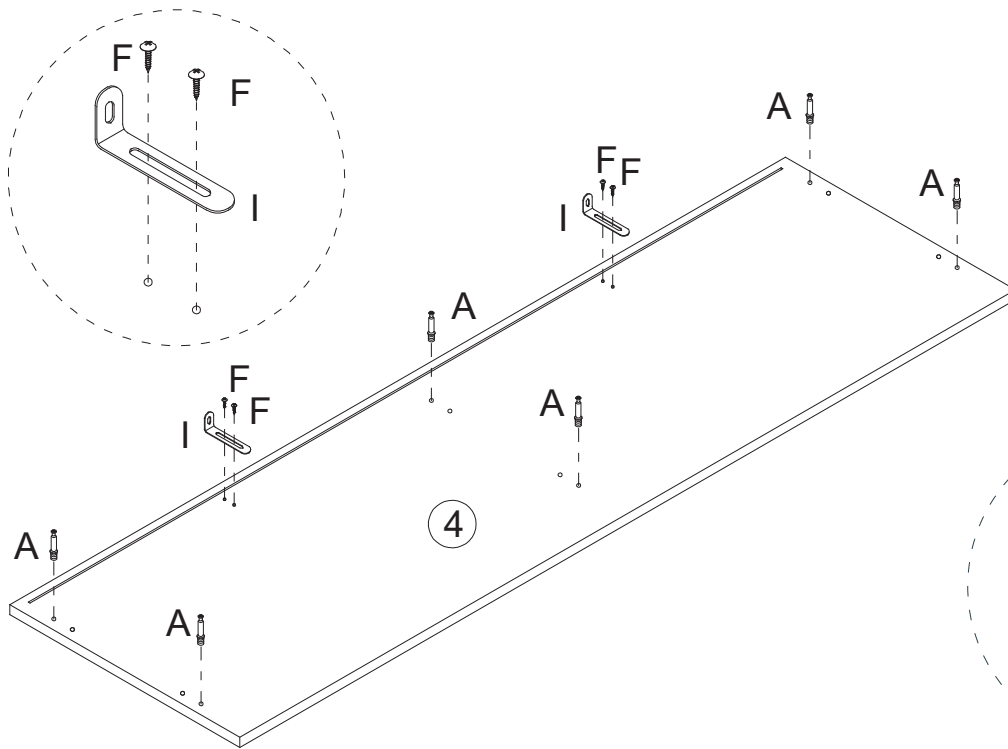



Step 15



Hardware Needed		
A		X6
F		X4
I		X2

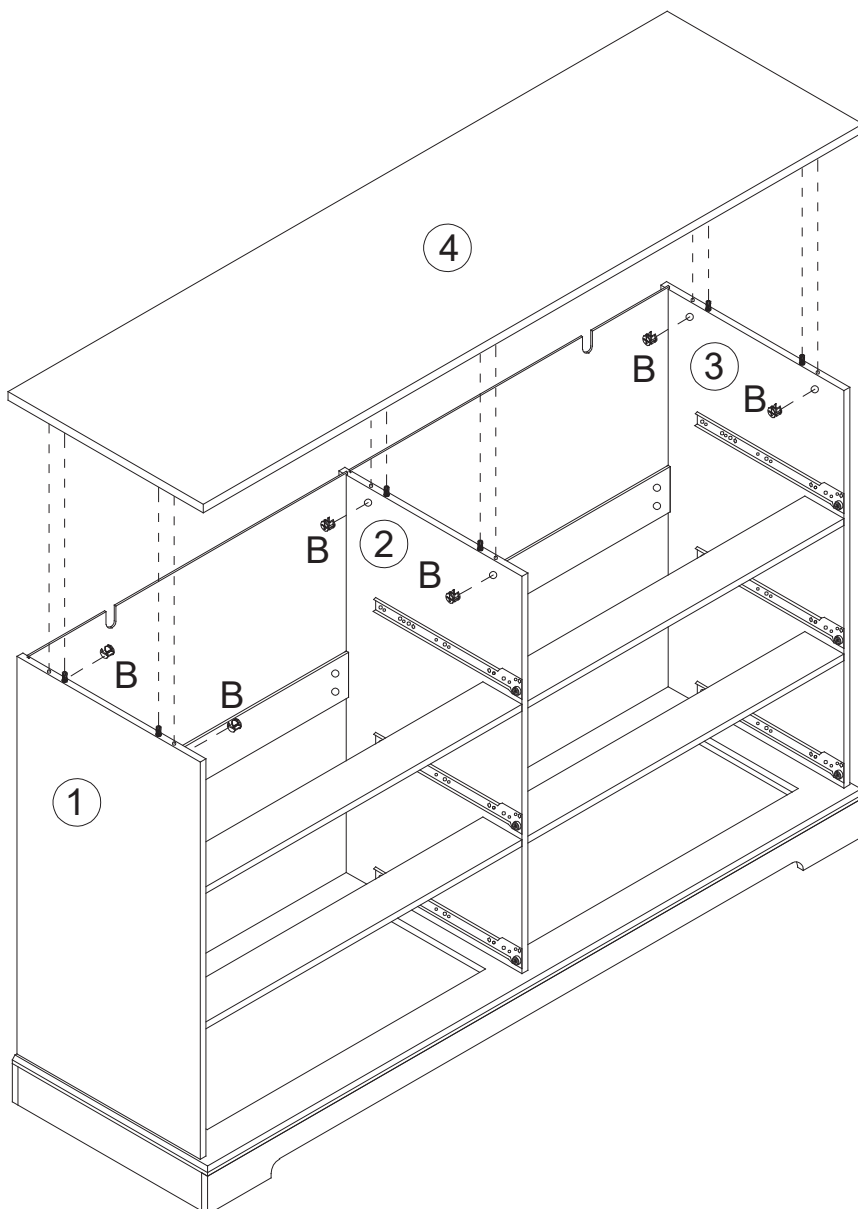

Step 16

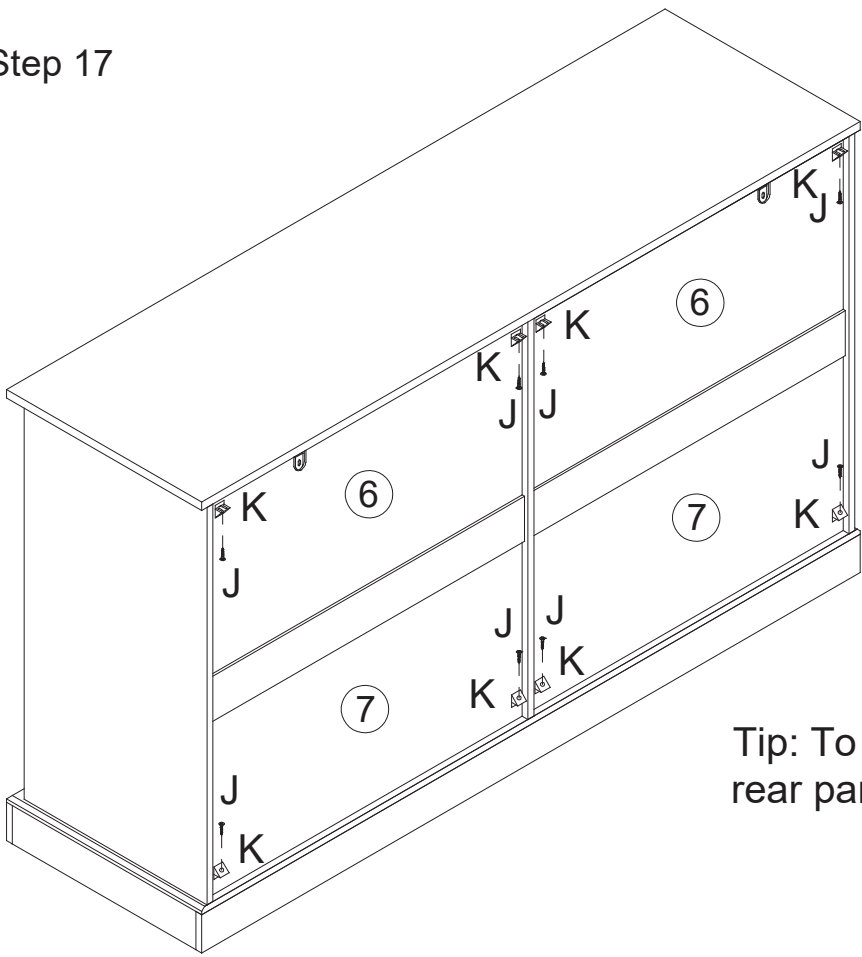

Hardware Needed		
B		X6

Step 17



Hardware Needed		
J		X8
K		X8

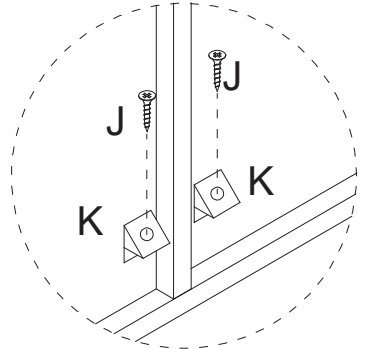

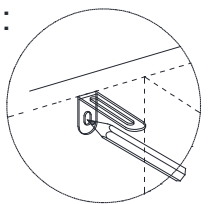
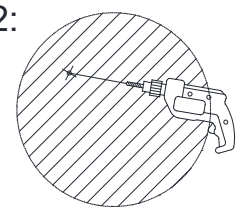
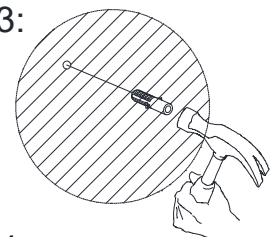
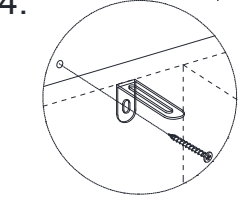

Tip: To increase stability please lock the rear panehooks at a right angle position.

Step 18

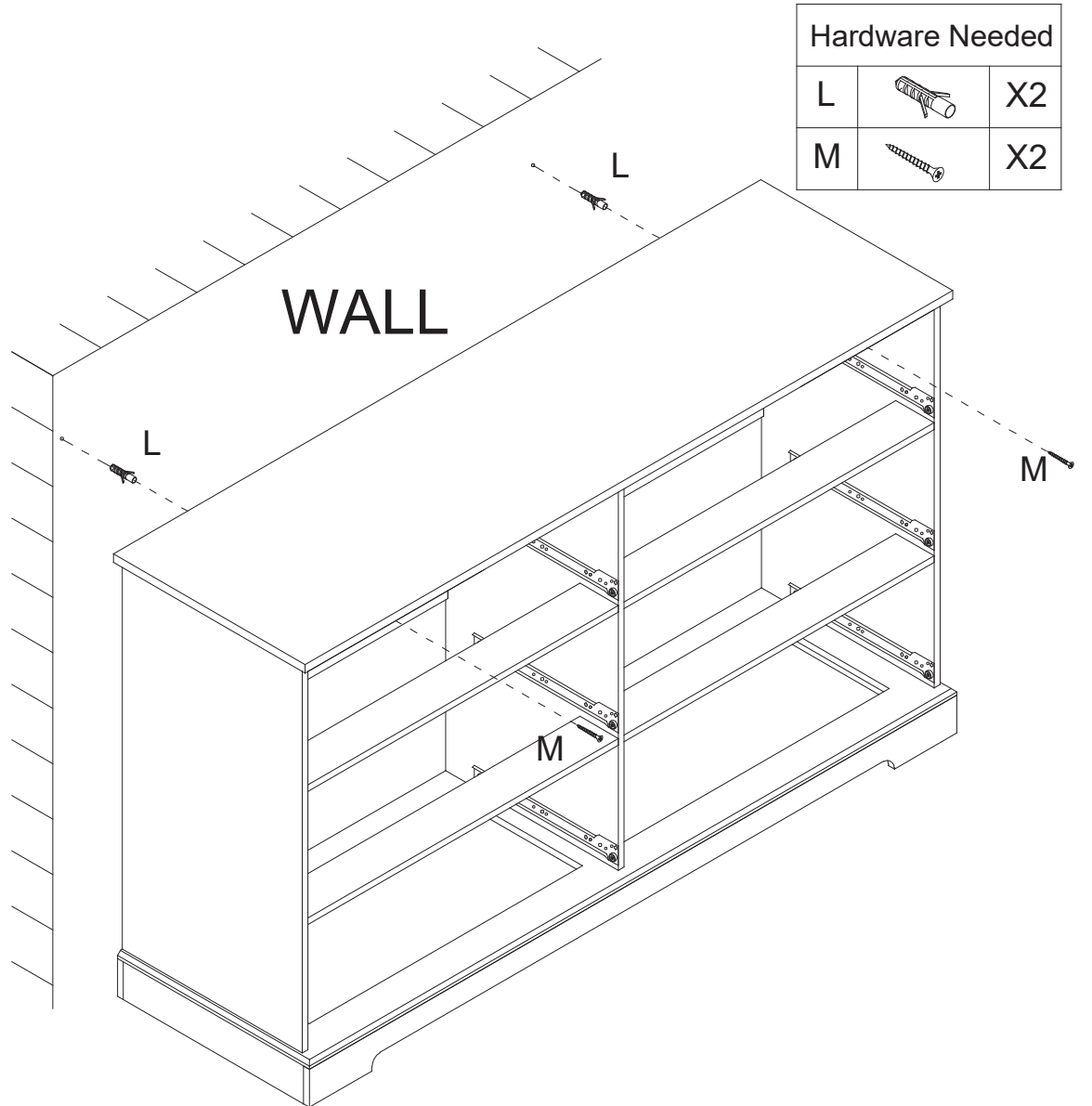
- 1: 
- 2: 
- 3: 
- 4: 



Hardware Needed		
L		X2
M		X2

Step 19

Hardware Needed		
E		X30

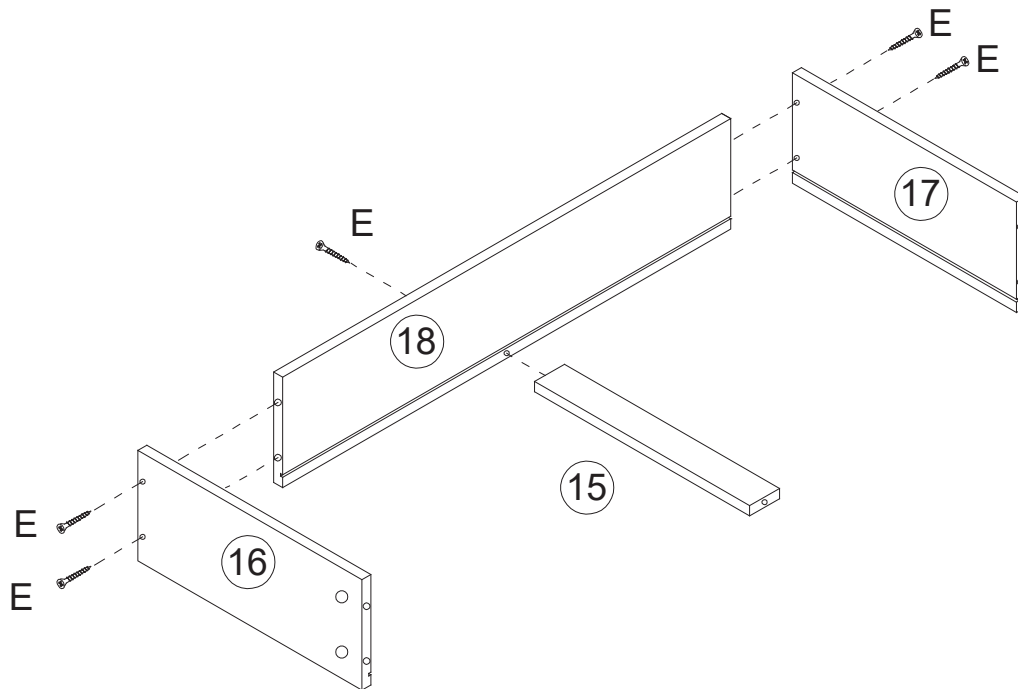

X6

Step 20

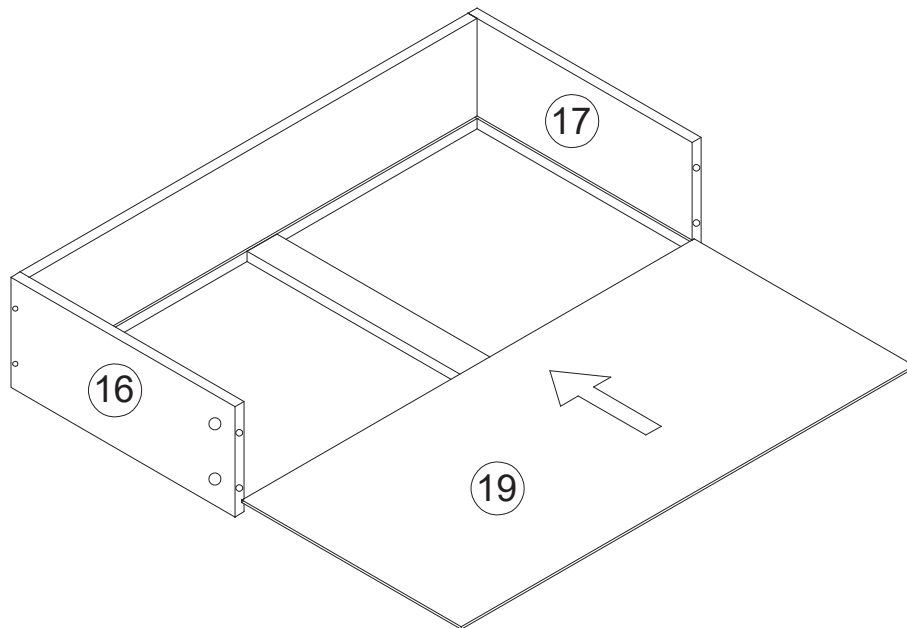

X6

Step 21

Hardware Needed

A



X30

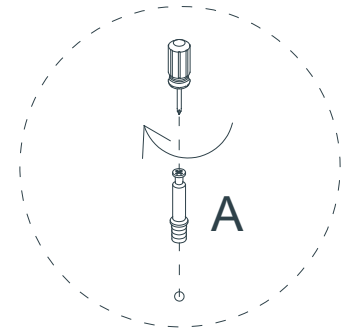
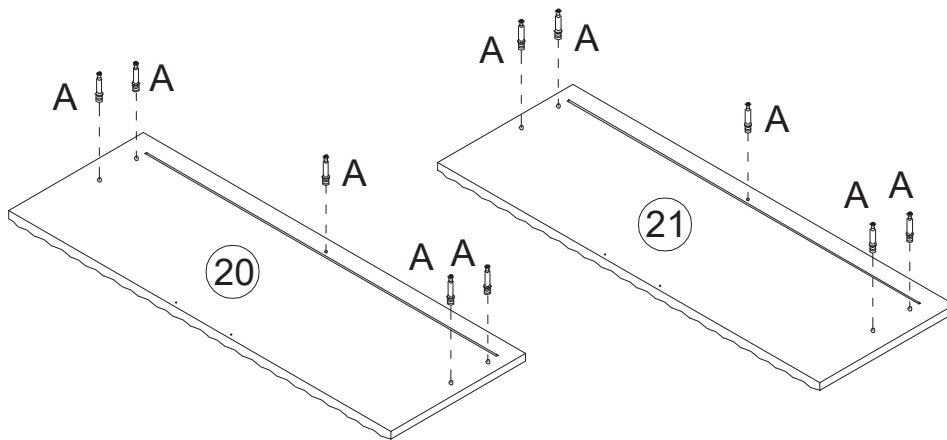

X3

Step 22

Hardware Needed

B



X30

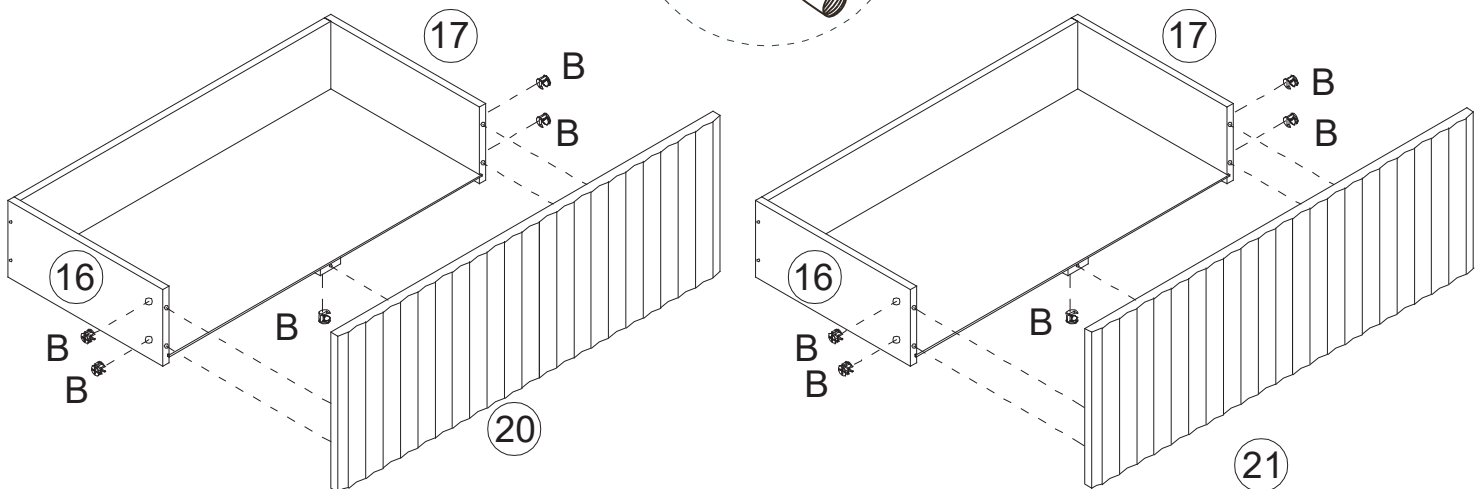
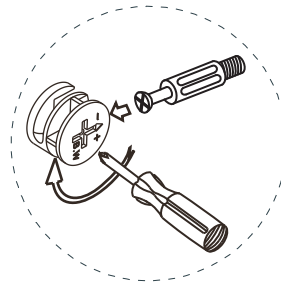

X3

Step 23

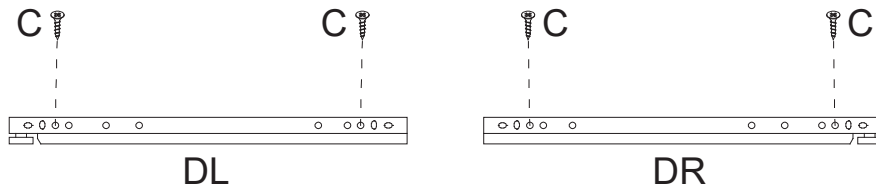

Hardware Needed		
DL		X6
DR		X6
C		X24

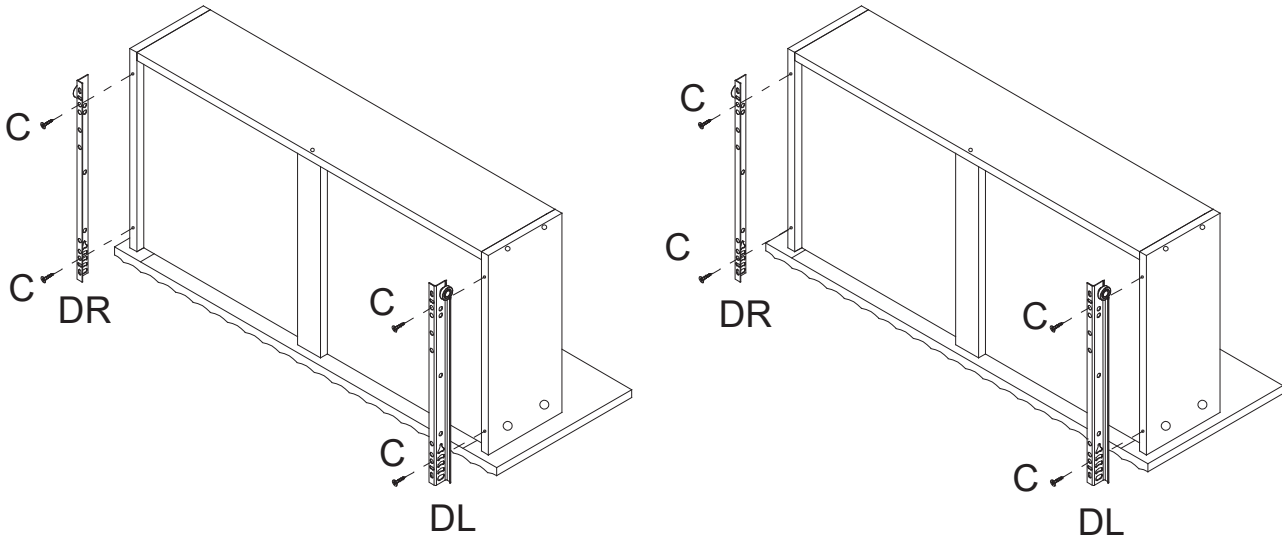

X3

Step 24

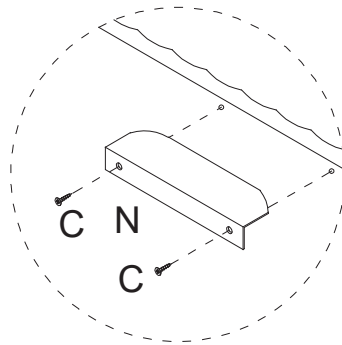

Hardware Needed		
C		X12
N		X6

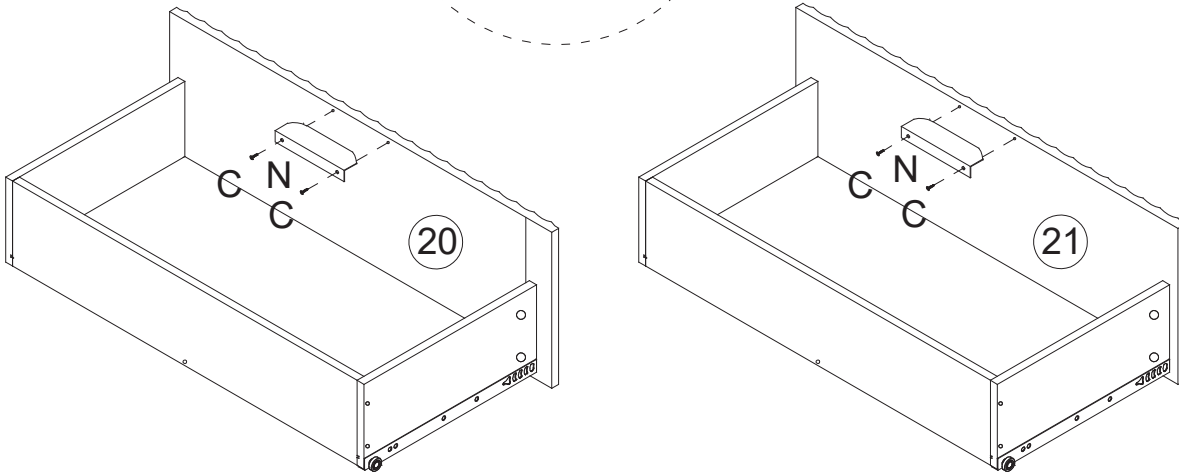

X3

Step 25

