



ASSEMBLY INSTRUCTION

ITEM # 7663-TWIN / 7665-TWIN / 7666-TWIN





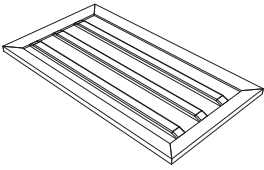
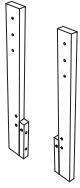

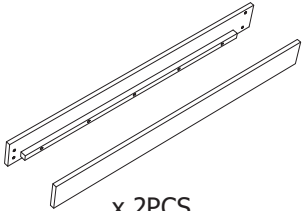
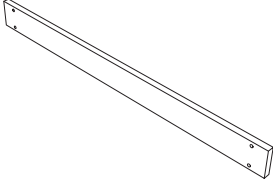
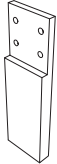
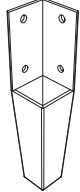
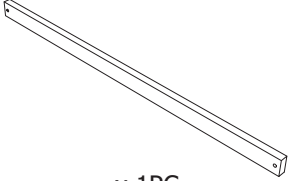
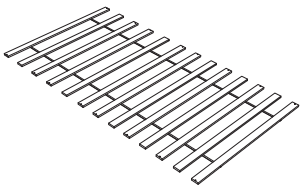
(SW1890TS - TWIN XL)

PART LIST

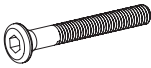
<p>1. HEADBOARD PANEL</p>  <p style="text-align: center;">x 1PC</p>	<p>2. HEADBOARD LEG (L/R)</p>  <p style="text-align: center;">x 2PCS</p>	<p>3. SIDE BED RAIL A (L/R)</p>  <p style="text-align: center;">x 2PCS</p>	<p>4. SIDE BED RAIL B (L/R)</p>  <p style="text-align: center;">x 2PCS</p>
<p>5. FOOTBOARD PANEL</p>  <p style="text-align: center;">x 1PC</p>	<p>6. CENTRE LEG</p>  <p style="text-align: center;">x 2PCS</p>	<p>7. LEG</p>  <p style="text-align: center;">x 2PCS</p>	<p>8. STRETCHER RAIL</p>  <p style="text-align: center;">x 1PC</p>
<p>9. ROLL SLAT</p>  <p style="text-align: center;">x 1SET</p>			

HARDWARE LIST (IN ACTUAL SIZE/SCALE FOR REFERENCE)

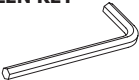
<p>A. JCBC BOLT M6 X 40mm</p>  <p style="text-align: center;">x 8PCS</p>	<p>B. JCBC BOLT M6 x 18mm</p>  <p style="text-align: center;">x 20PCS</p>	<p>C. SPRING WASHER M6</p>  <p style="text-align: center;">x 28PCS</p>	<p>D. FLAT WASHER M6</p>  <p style="text-align: center;">x 28PCS</p>	<p>E. CSK SCREW M4 X 25mm</p>  <p style="text-align: center;">x 16PC</p>
<p>F. ALLEN KEY M4</p>  <p style="text-align: center;">x 1PC</p>				

Read this instructions carefully.

See hardware and furniture part list for guidance. Be sure all parts are complete before you assemble. Place all wooden furniture parts on a clean and flat soft surface to prevent from being scratched. Follow the figure so start assembling.



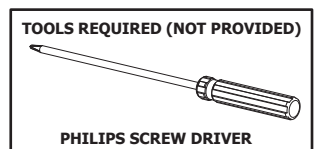

CAUTIONS :

1. DO NOT **Fully -Tighten** the bolt until all bolt are ready for assembled.
2. DO NOT **Over-Tighten** the bolt to avoid damaging the thread.
3. Keep all hardware parts stay away from children.

NOTE : THE LIST AND QUANTITY SHOWN ARE FOR 1 UNIT ASSEMBLY.





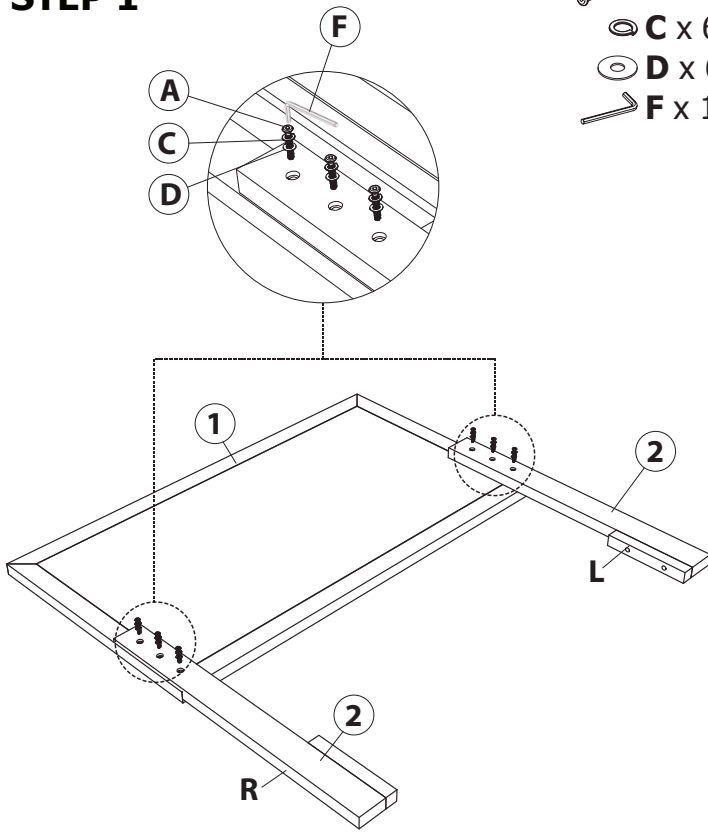

STEP 1

-  A x 6
-  C x 6
-  D x 6
-  F x 1



Place Headboard Leg (2) on the bottom Right (R) and Left (L) side of the Headboard Panel (1) and attach by inserting M6x40mm Bolt (A), Spring Washer (C), and Flat Washer (D). Then tighten the bolts clockwise with Allen Key (F) until secure.



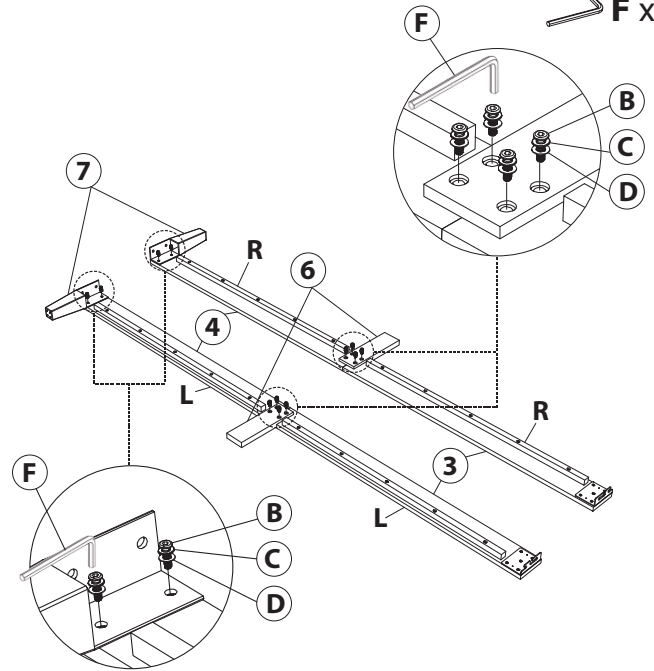

STEP 2

-  B x 12
-  C x 12
-  D x 12
-  F x 1



Attach the Leg (7) to end of each Right (R) & Left (L) Siderail (4) by using M6x18mm Bolt (B), Spring Washer (C), and Flat Washer (D), and tighten clockwise using Allen Key (F). Then connect both Siderails (3 & 4) by using the Centre Leg (6) and secure with M6x18mm Bolt (B), Spring Washer (C), and Flat Washer (D), and tighten clockwise using Allen Key (F).

STEP 3

-  B x 4
-  C x 4
-  D x 4
-  F x 1

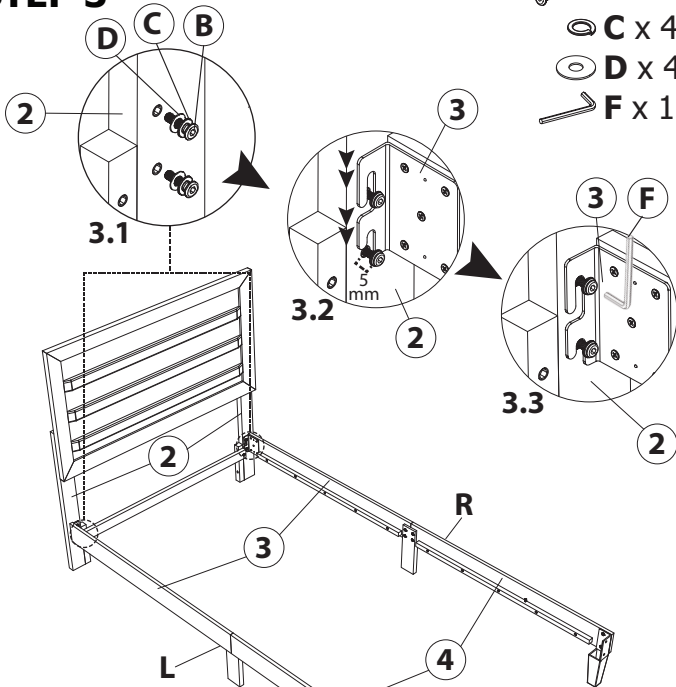





3.1 Insert M6x18mm Bolts (B), Spring Washer (C), and Flat Washer (D) clockwise inside the thread of Headboard Leg (2) on both Left (L) & Right (R) side. Do not insert the Bolts (B) all the way in, leave out about 5mm length.

3.2 Hook Siderail (3) on the M6x18mm Bolts (B) attached on Headboard Leg (2).

3.3 Tighten the Bolts (B) using Allen Key (F).



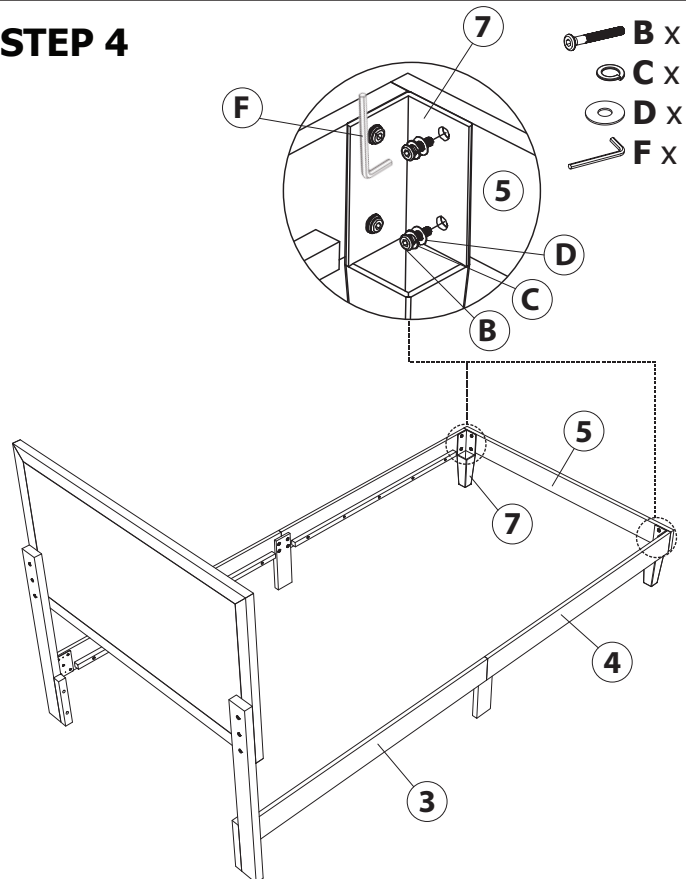

STEP 4

-  B x 4
-  C x 4
-  D x 4
-  F x 1



Attach the Footboard (5) to the Leg (7) with M6x18mm Bolts (B), Spring Washer (C), and Flat Washer (D) and tighten using the Allen Key (F).

STEP 5

-  **A** x 2
-  **C** x 2
-  **D** x 2
-  **F** x 1

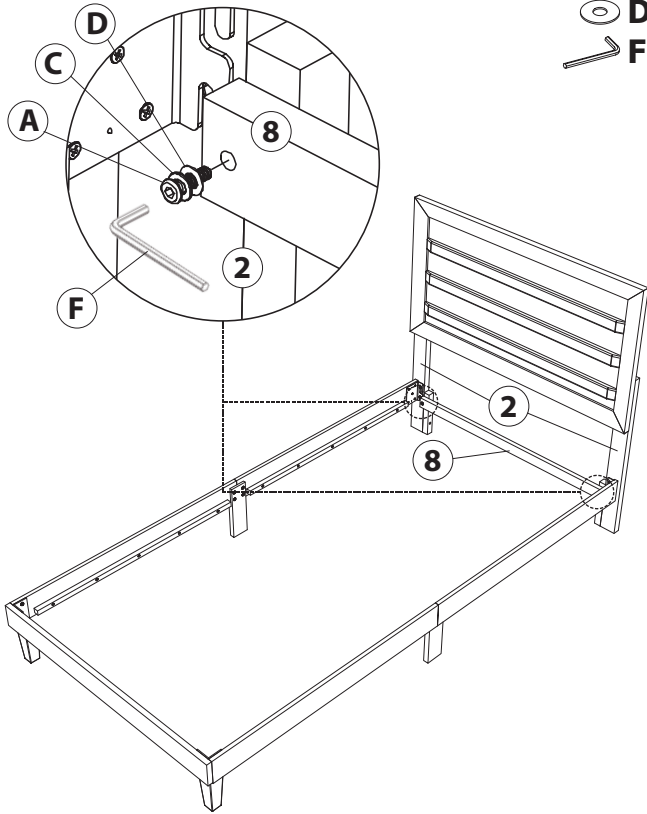

Attach the Stretcher Rail (8) to the Headboard Leg (2) with M6x40mm Bolt (A), Spring Washer (C), and Flat Washer (D). Then tighten the bolts clockwise using Allen Key (F) until secure.

STEP 6

-  **E** x 16

NOTE:
This mark on the "Slat" marking for this side must be on the "Head Board" position.

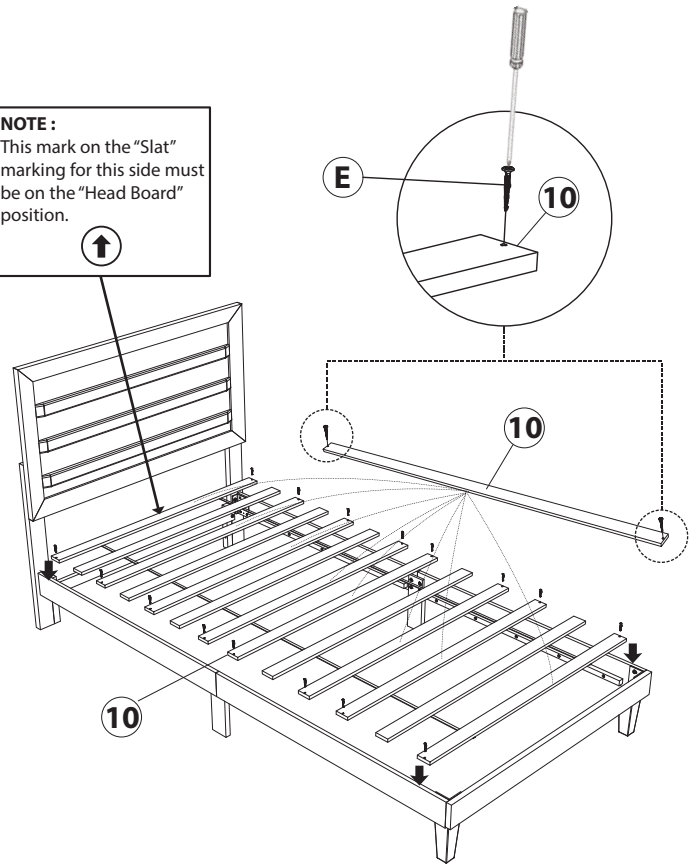

Attach Roll Slat (10) to both Sidebed Rails (3 & 4) with M4x25mm Screw (E). Please see Note above. Tighten the Screw (E) with the Philips Screw Driver (Not Provided).

ASSEMBLY COMPLETE

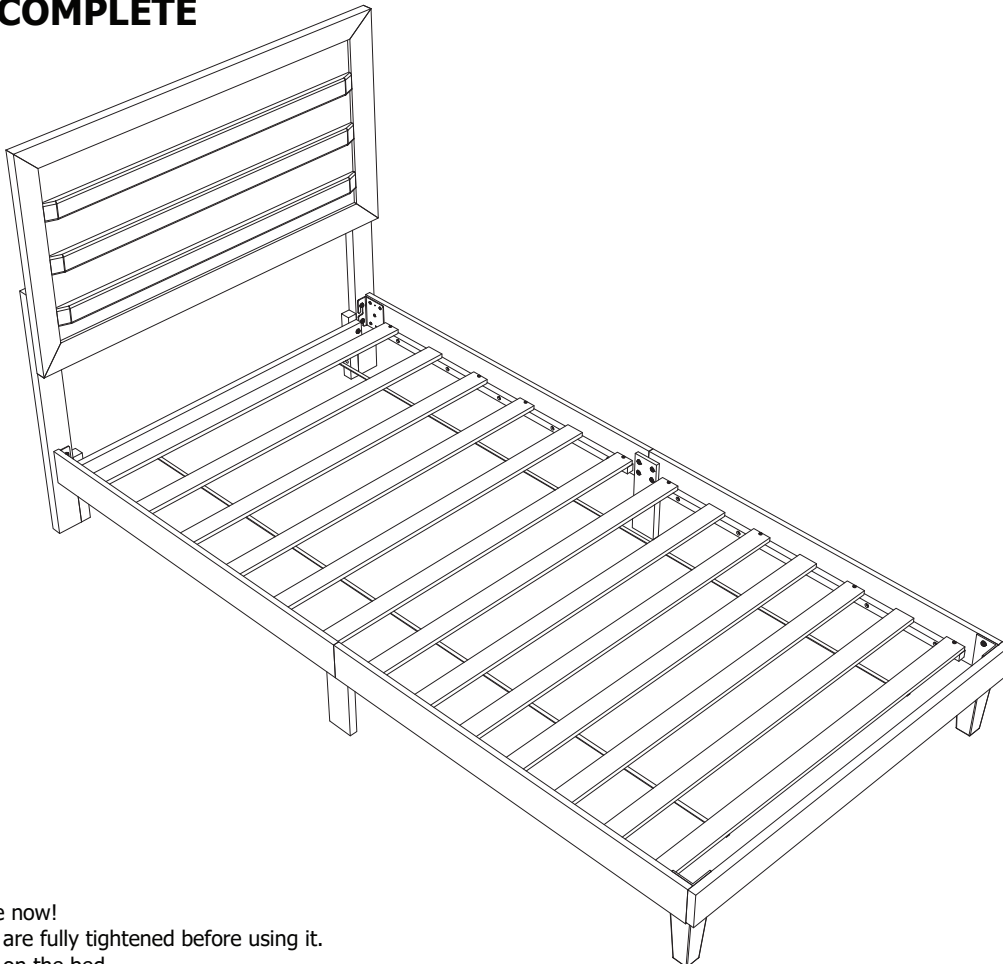

Your bed is ready to use now!
Make sure all the screw are fully tightened before using it.
DO NOT Jump or Stand on the bed.